

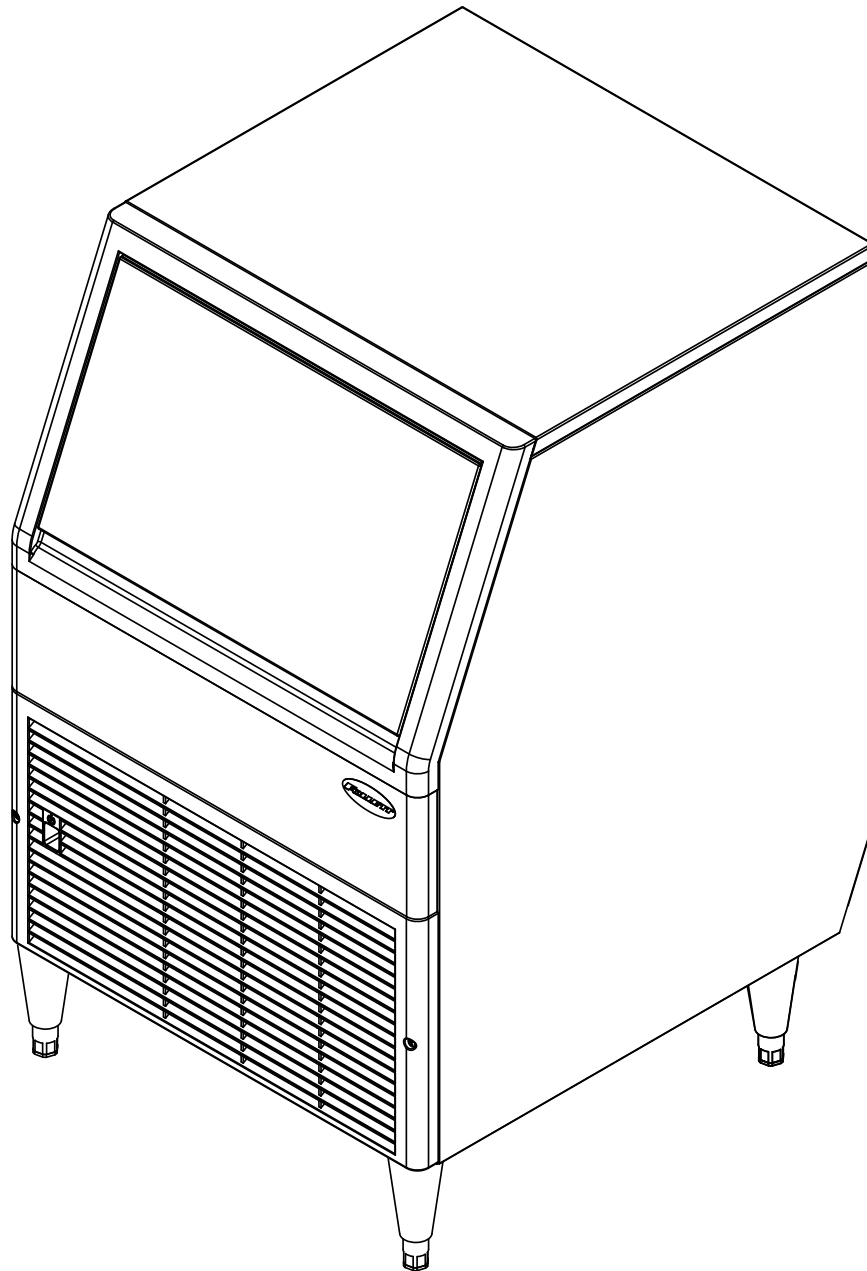

# Undercounter and Freestanding Integrated Icemaker

Installation, Operation and Service Manual



**Following installation, please forward this manual  
to the appropriate operations person.**

# Contents

<b>Welcome</b> .....	<b>3</b>
Before You Begin .....	3
<b>Important Safety Information</b> .....	<b>4</b>
<b>Specifications</b> .....	<b>5</b>
Electrical .....	5
Plumbing .....	5
Ambient .....	5
Heat Rejection .....	5
Ice Production Chart .....	6
Dimensions .....	6
Clearances .....	6
Water .....	6
Refrigeration .....	6
<b>Detailed Drawing</b> .....	<b>7</b>
<b>Installation</b> .....	<b>8</b>
Uncrating Information .....	8
Undercounter Installation .....	9
Freestanding Model Installation .....	10
<b>Start-Up Procedure</b> .....	<b>11</b>
Before turning power on .....	11
After turning power on .....	11
<b>Periodic Cleaning and Sanitizing</b> .....	<b>12</b>
Condenser .....	12
Cleaning/Descaling and Sanitizing .....	12
<b>Service</b> .....	<b>16</b>
Overview .....	16
<b>Accessing Internal Components</b> .....	<b>17</b>
Ice Bin Removal .....	17
<b>Water System</b> .....	<b>18</b>
<b>Electrical System</b> .....	<b>20</b>
<b>Starting Procedure</b> .....	<b>22</b>
Diagnostic Stages .....	27
<b>Wiring Diagram</b> .....	<b>31</b>
<b>Compressor Data</b> .....	<b>32</b>
Compressor Current Draw at 115 Vac .....	32
Compressor Current Draw at 220 Vac .....	32
Compressor Current Draw at 230 Vac .....	32
Gearmotor Data .....	32
Fan Motor Data .....	32
<b>Mechanical System</b> .....	<b>33</b>
Evaporator Disassembly .....	33
Evaporator Reassembly .....	34
<b>Refrigeration System</b> .....	<b>35</b>
Refrigeration Charge .....	35
<b>Troubleshooting</b> .....	<b>37</b>
<b>Replacement Parts</b> .....	<b>38</b>

## Welcome

Follett equipment enjoys a well-deserved reputation for excellent performance, long-term reliability, and outstanding after-the-sale support. To ensure that this product delivers that same degree of service, we ask that you take a moment to review this manual before beginning the installation. Should you have any questions or require technical help at any point, please call our technical service group at +48 58 785 61 40 for European market, and +1 877-612-5086 for US market.

## Before You Begin

After uncrating and removing all packing material, inspect the equipment for concealed shipping damage. If damage is found, immediately notify the shipper and contact Follett Corporation so that we can help in the filing of a claim, if necessary. If needed, the serial number of your dispenser can be found by removing the grill and locating the serial number label **(1)** on the bin and on the bottom of the main frame **(2)**.

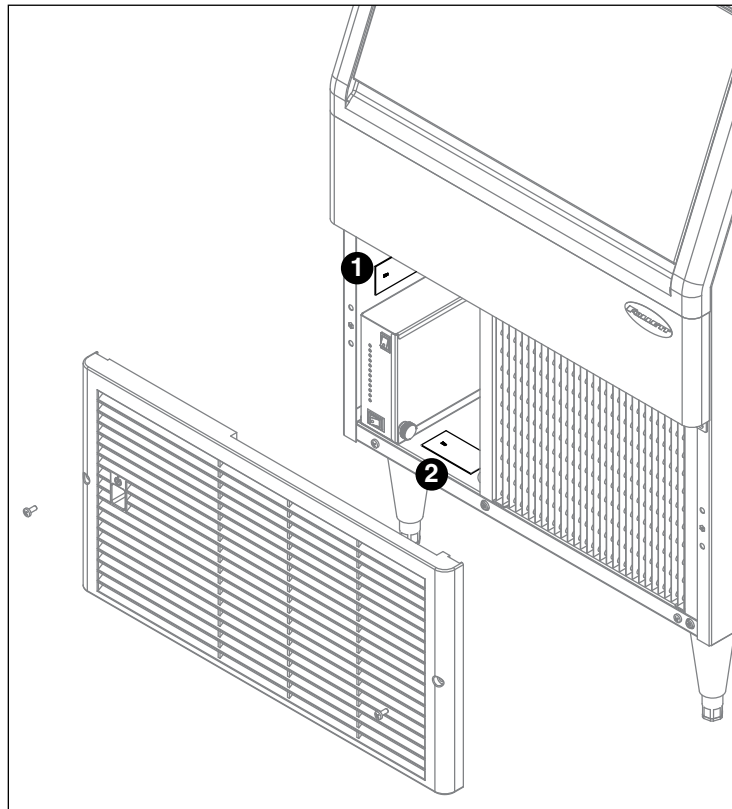

Check your paperwork to verify that you received the correct dispenser. Follett configuration numbers are designed to provide information about the type of dispenser you are receiving. The following is an explanation of the different model numbers.

U	F	C	425	A	80
Product Type	Ice Type	Voltage	Icemaker Capacity	Condenser	Bin Capacity
<b>U</b> Undercounter	<b>F</b> Flake <b>M</b> Micro Chewblet	<b>C</b> 220/60 <b>D</b> 115/60 <b>E</b> 230/50	<b>425</b> Up to 425 lbs.	<b>A</b> Air cooled	<b>80</b> 80 lbs.

## Important Safety Information

### CAUTION!

- For indoor use only. Designed for commercial use. Follett is not able to provide in-house services for residential installations.
- This appliance should be permanently connected by a qualified person in accordance with application codes.
- If the supply cord is damaged, it must be replaced by the manufacturer, its service agent or similarly qualified persons in order to avoid a hazard.
- Connect to potable water supply only.
- This appliance can be used by children aged 8 years and above and persons with reduced physical, sensory, or mental capabilities, or lack of experience and knowledge if they have been given supervision or instruction concerning use of the appliance in a safe way and understand the hazards involved. Children should be supervised to ensure that they do not play with the appliance.
- Children should not be allowed to perform any maintenance of this appliance.
- Do not store explosive substances such as aerosol cans with a flammable propellant inside the bin!
- Warranty does not cover exterior or outside installations.
- Moving parts. Do not operate with front cover removed.
- Hot parts. Do not operate with cover removed.
- To reduce risk of shock, disconnect power before servicing.
- Follett recommends water filtration system. Contact Follett for more information.
- Most icemaker cleaners contain citric or phosphoric acid, which can cause skin irritation. Read caution label on product and follow instructions carefully.
- Ice is slippery. Maintain counters and floors around dispenser in a clean and ice-free condition.
- Ice is food. Follow recommended cleaning instructions to maintain cleanliness of delivered ice.
- To avoid potential contamination do not use the surface of the unit as a worktop.

## Specifications

### Electrical

- Power supply:
  - 230 V, 50/60 Hz, 1 phase, maximum machine amperage 4.5A, maximum fuse 10A (UME/UMC/UFE/UFC models)
  - 115 V, 60 Hz, 1 phase, maximum machine amperage 9.0A, maximum fuse 15A (UMD/UFD models)
- Connect to dedicated circuit.
- Must be grounded (requires 3-prong outlet). Do not remove ground.
- Replacement cord instructions, if the supply cord is damaged, it must be replaced by a special cord or assembly available from the manufacturer or its service agent.

### Plumbing

- 3/8" OD push-in water inlet
- 3/4" MPT drain

#### Notes:

- 3/4" drain line must slope 1/4" per foot (6 mm per 30,4 cm run). Maximum drain line run is 6 ft (1.8 m) for units without 6" legs.
- Drain to be hard piped and insulated.
- To prevent back flow, do not connect drains.
- Water shut-off recommended within 5 ft (1,5 m), drain to be hard piped and insulated.
- Follett recommends a Follett water filter system be installed in the ice machine inlet water line (standard capacity #00130229, high capacity #00978957, carbonless high capacity #01050442).

### Ambient

#### CAUTION!

- This unit is for indoor use only.

Air temp*	100 F/38 C max.	50 F/10 C min. Best performance below 80 F (27 C)
Water temp†	90 F/32 C max.	40 F/7 C min. Best performance below 70 F (21 C)
Water pressure	70 PSI/5 Bar max.	10 PSI/0.7 Bar min.
Relative humidity	55% at 78 F (25,5 C)	

\* Use outside of these limits is misuse and will void warranty.

† Best performance is achieved between 80 F (27 C) and 50 F (10 C).

### Heat Rejection

- 5000 BTU/hr

## Ice Production Chart

Air-Cooled icemaker capacity/24hrs.

Ambient Air Temperature F/C

	F	60	70	80	90	100	
	C	16	21	27	32	38	
Inlet Water Temperature F/C	50	510	454	397	335	273	lb
	10	232	206	180	152	124	kg
	60	484	435	389	329	270	lb
	16	219	198	177	150	123	kg
	70	454	417	380	323	266	lb
	21	206	190	173	147	121	kg
	80	424	385	347	297	247	lb
	27	193	175	158	135	112	kg
	90	394	354	313	270	227	lb
	32	179	161	142	123	103	kg

## Dimensions

Width	23.43" (59,5 cm)
Depth	25.98" (66,0 cm)
Height	32.99" (83,8 cm)
Height with legs	38.90" (98,8 cm)
Unit shipping weight	185 lb (84 kg)
Unit net weight	154 lb (70 kg)

## Clearances

- This unit is a front-breathing device. No side and back clearances needed.

## Water

### CAUTION!

- Connect to potable water supply only.
- Not recommended for use with softened water
- Ingress Protection (IP) rating: IPX0 (no protection)
- Water pressure: 10–70 psi (69–483 kPa)

## Refrigeration

### CAUTION!

- Do not damage the refrigerant circuit. Refrigerant can cause personal injury and/or damage dispenser.
- Refrigerant R404a – 435 g (15.34 oz.).

# Detailed Drawing

## With 6" Legs

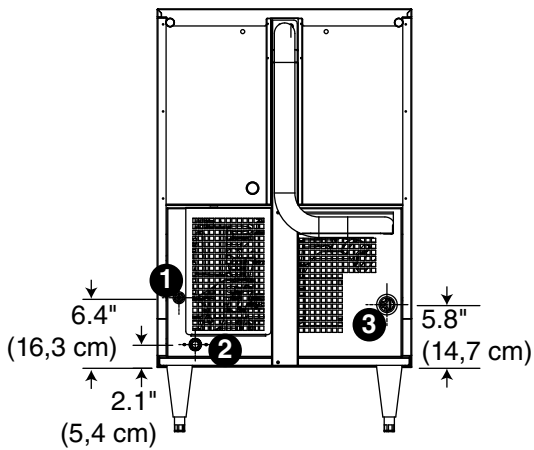
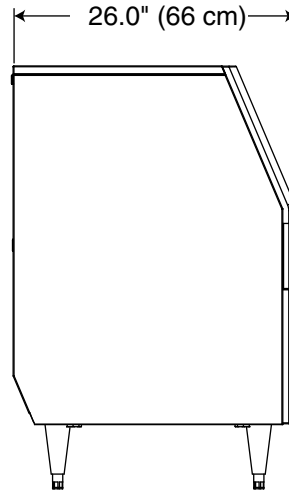
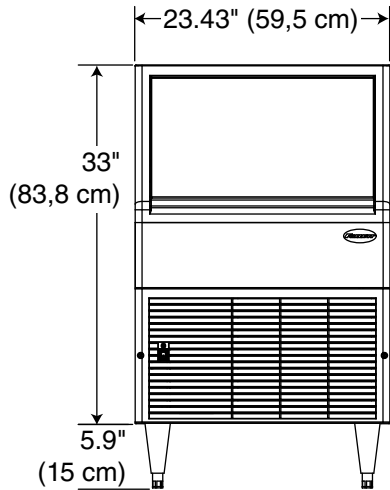

- ❶ 3/8" OD push-in water inlet
- ❷ 3/4" MPT drain outlet
- ❸ Power supply cable entry grommet
- ❹ Power cord connection

## With Leveling Feet

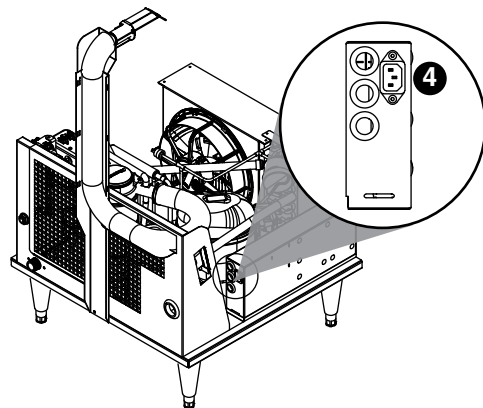
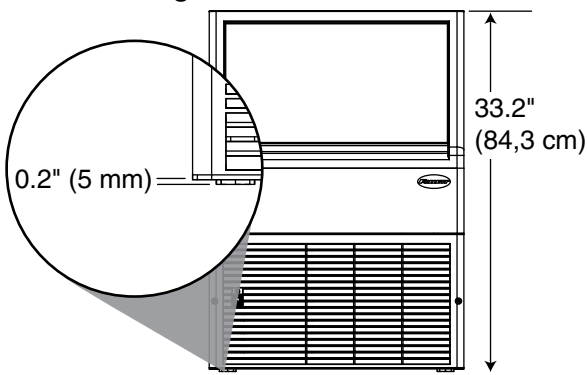

# Installation

## CAUTION!

- For indoor use only. Designed for commercial use. Follett is not able to provide in-house services for residential installations.
- Use caution when tipping the dispenser during leg installation. Do not lay unit on back or side. DO NOT EXCEED 30° angle. Tipping more than 30° can result in compressor malfunction.

### Uncrating Information

1. Carefully unpack and inspect the contents of your Follett icemaker.
2. Unscrew all four bolts fastening the machine to the skid.
3. Slide the unit to one side of the skid and screw in supplied accessory leg set or leveling feet according to your machine setup.

Fig. 1

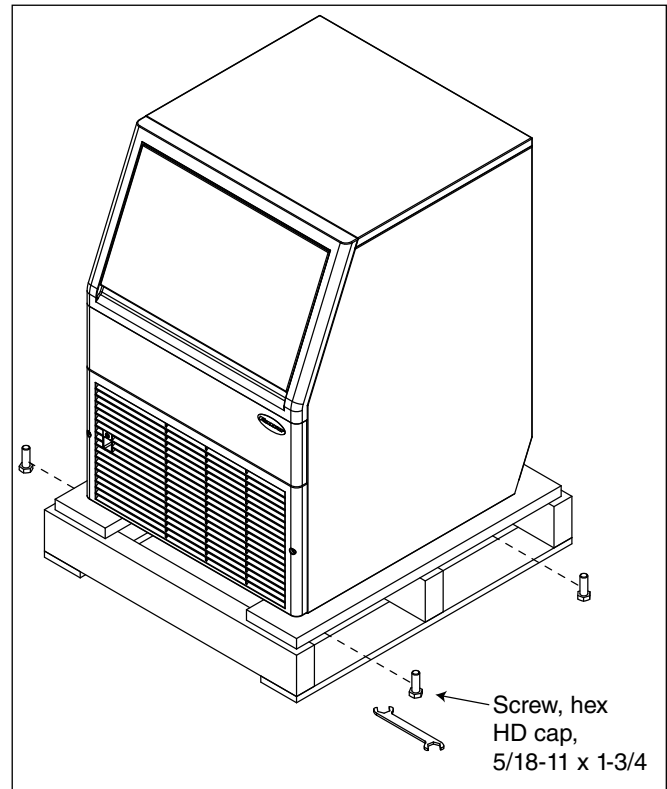
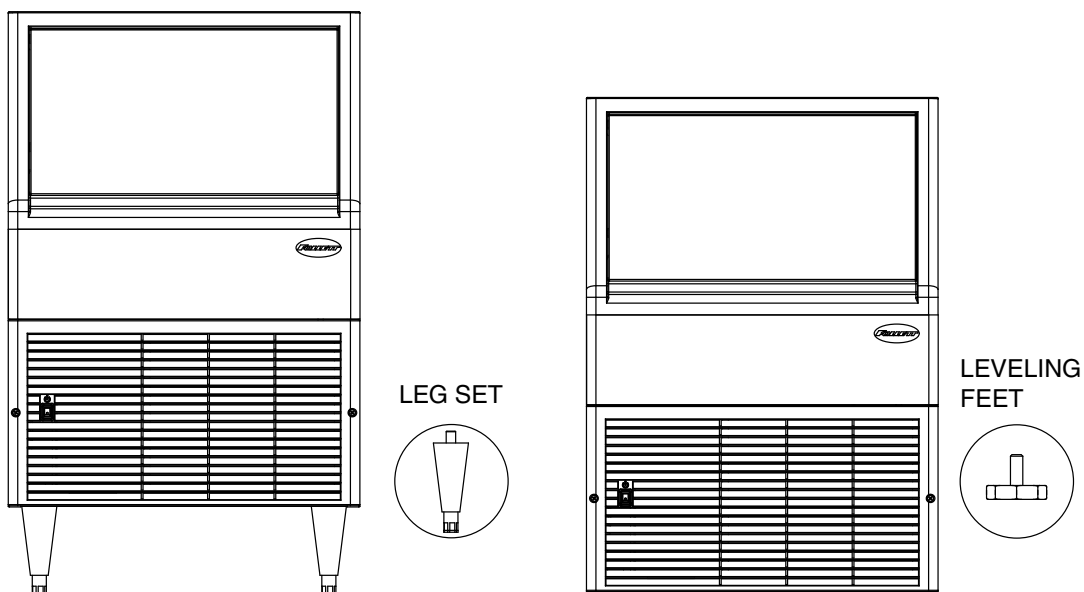

Fig. 2 - Leg Set (Freestanding) or Leveling Feet (Undercounter) Option





## Undercounter Installation

Install icemaker section first, to ease installation procedure. Installation instructions for freestanding model may be found on page 10.

### Bin portion must be removed after uncrating

1. Remove the front grille (**Fig. 3.1**).
2. Remove two screws behind the grille (**Fig. 3.2**).
3. Remove the drain tube from the ice bin (**Fig. 4**).
4. Facing the unit, slide the bin out by pulling it towards you.

### Rough-in the electrical service and water line

- Unit is provided with a 2.4 m IEC power cord.\*
  - UFC, UMC family (220 V/60Hz)
  - UFE, UME family (230 V/50 Hz)
- For 115/60Hz market the UFD, UMD family comes with NEMA 5-15A grounded – complete power cord with plug
- Water: supply line (with shut-off valve) connects to the dispenser's (3/8" OD push-in water inlet)

**Note: This appliance is intended to be permanently connected to water main using 3/8" OD tubing.**

1. Connect water line and drain. Maximum drain line run is 6 ft (1.8 m). Recommended routing (**Fig. 5**) allows easy access to water for cleaning and sanitizing procedure. Verify the bin drain shut-off valve is open (**Fig. 4**).
2. Connect power supply.
3. Unit must be level to operate properly.
4. Install bin portion after all supplies are connected.
5. Sanitize the dispenser prior to use (see Cleaning and Sanitizing on page 11).

\* Depending on the market, the user must install the proper plug per local electrical code (plug not included.)

Fig. 3

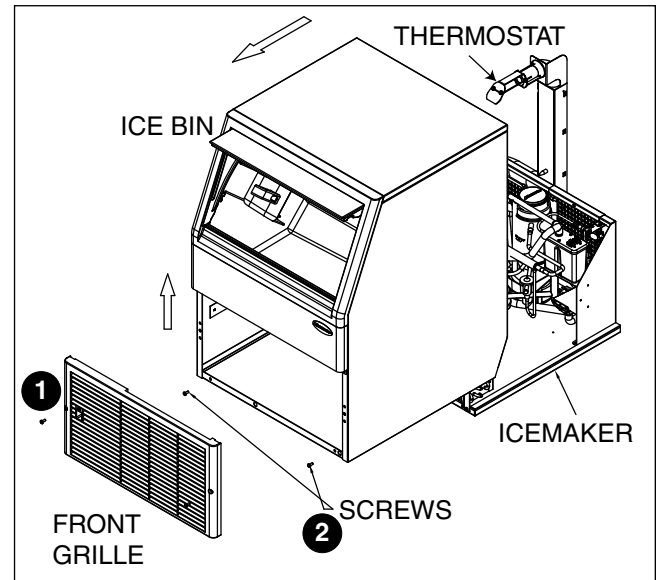

Fig. 4

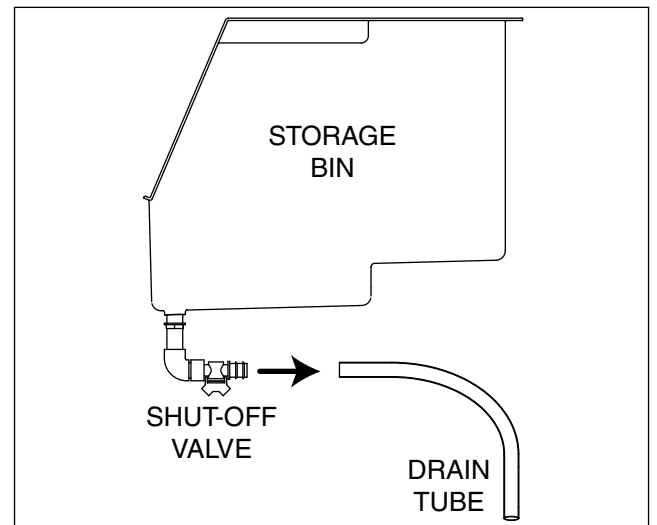
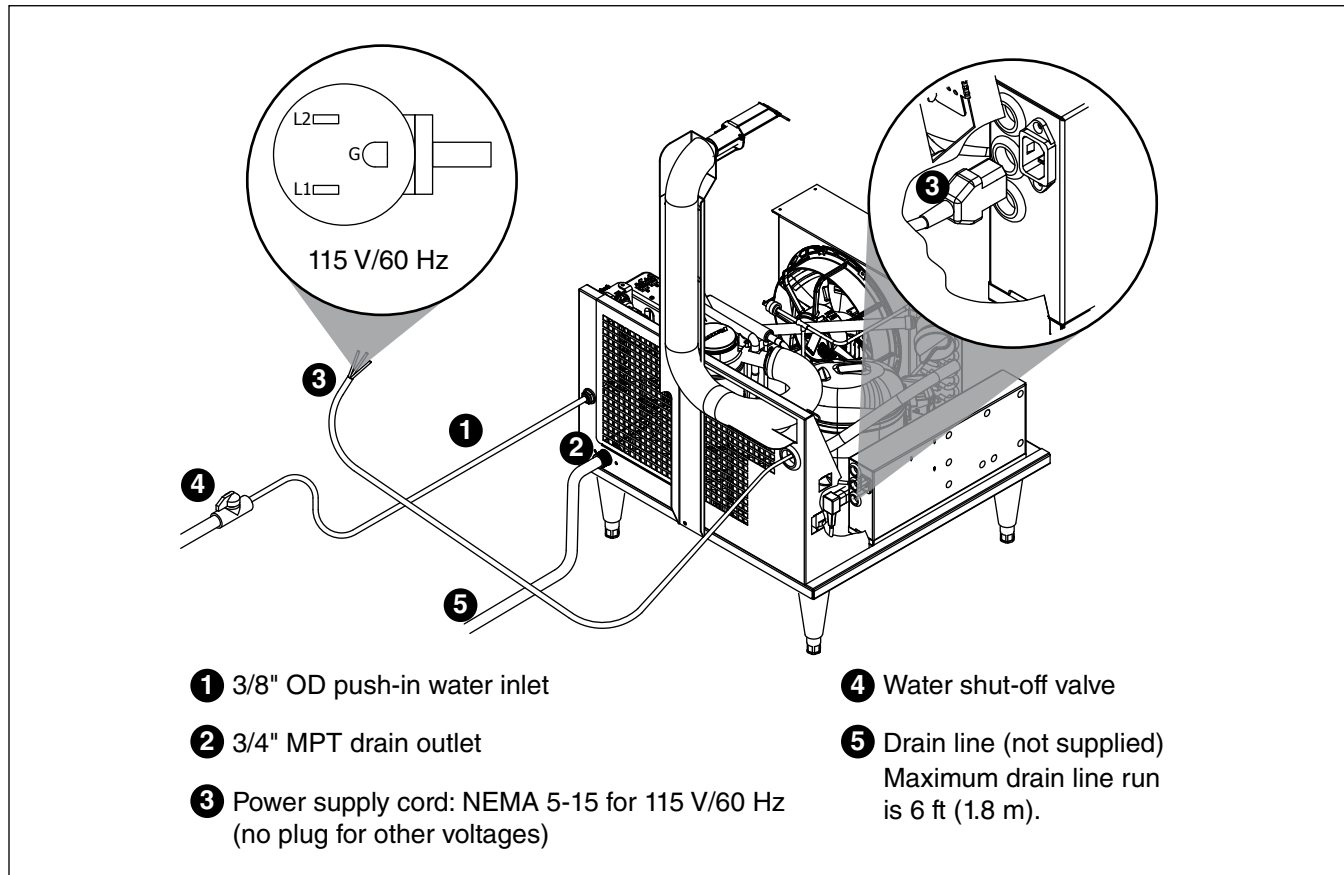

Fig. 5 - Undercounter



## Freestanding Installation

### 1. Rough-in the electrical service and water line

Unit is provided with a 2.4 m IEC power cord. Depending on the market, the user must install the proper plug per local electrical code (plug not included.):

— UFC, UMC family (220 V/60 Hz)

— UFE, UME family (230 V/50 Hz)

▪ For 115 V/60 Hz market the UFD, UMD family comes with NEMA 5-15A grounded – complete power cord with plug.

▪ Water: supply line (with shut-off valve) connects to the dispenser's 3/8" OD push-in water inlet.

**Note: This appliance is intended to be permanently connected to water main using 3/8" OD tubing.**

2. Connect water line and drain. Recommended routing (**Fig. 6**) allows easy access to water for cleaning and sanitizing procedure. Ensure that the water drain valve is open (**Fig. 4**).

3. Connect power supply.

4. Ensure that the unit is level. Unit must be level to operate properly.

5. Sanitize the dispenser prior to use (see Cleaning and Sanitizing on page 12).

**Fig. 6 - Freestanding**

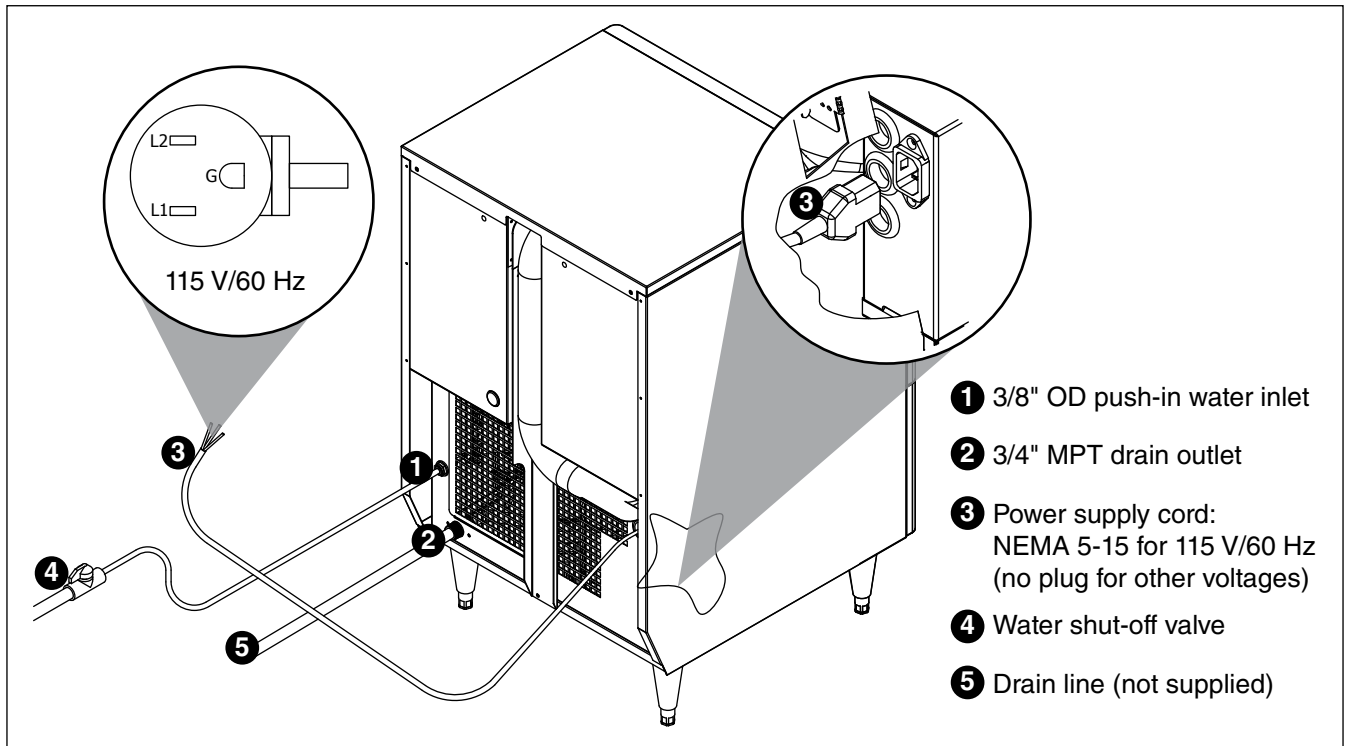

## Start-Up Procedure

### Before turning power on

1. Clean and sanitize ice bin in accordance with cleaning procedure.
2. Turn water to icemaker ON.

### After turning power on

1. Turn ON the machine with on/off switch and confirm that gearmotor, compressor and fan motor start.
2. Check that ice begins to enter bin within approximately 5 minutes.
3. After making ice for 5 minutes, put ice against ice level thermostat tube (**Fig. 7**) and check that icemaker shuts down.
4. Warm the ice level thermostat tube with your fingers and check that icemaker restarts in approximately 20 minutes (bin must be calling for ice).

**Fig. 7**

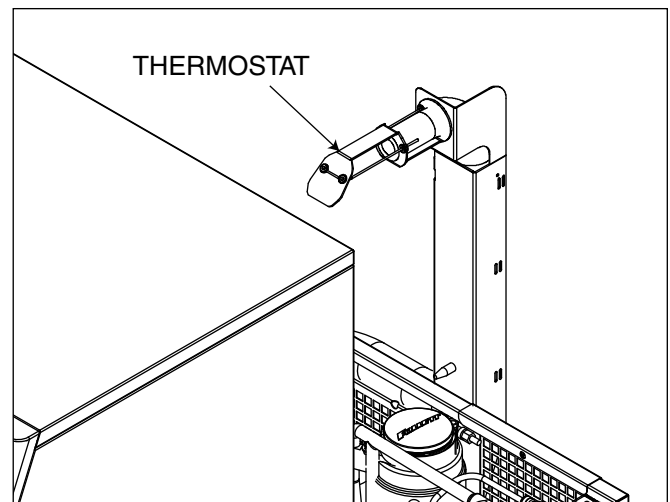

## Periodic Cleaning and Sanitizing

Periodic cleaning/descaling and sanitizing of Follett's ice and water dispenser and icemaker system is required to ensure peak performance and delivery of clean, sanitary ice. The recommended cleaning procedures that follow should be performed at least as frequently as recommended and more often if environmental conditions dictate.

Cleaning of the condenser can usually be performed by facility personnel. Cleaning/descaling and sanitizing of the icemaker system should be performed by your facility's trained maintenance staff or a Follett authorized service agent. Regardless of who performs the cleaning, it is the operator's responsibility to see that this cleaning is performed according to the schedule below. Service problems resulting from lack of preventive maintenance will not be covered under the Follett warranty.

### Condenser

Unit is supplied with condenser filter (**Fig. 8**). At least once per month use a vacuum cleaner or stiff brush to clean condenser filter and evaporator coils of lint and debris to ensure optimal performance. To access condenser filter remove plastic front cover grille.

**Fig. 8**

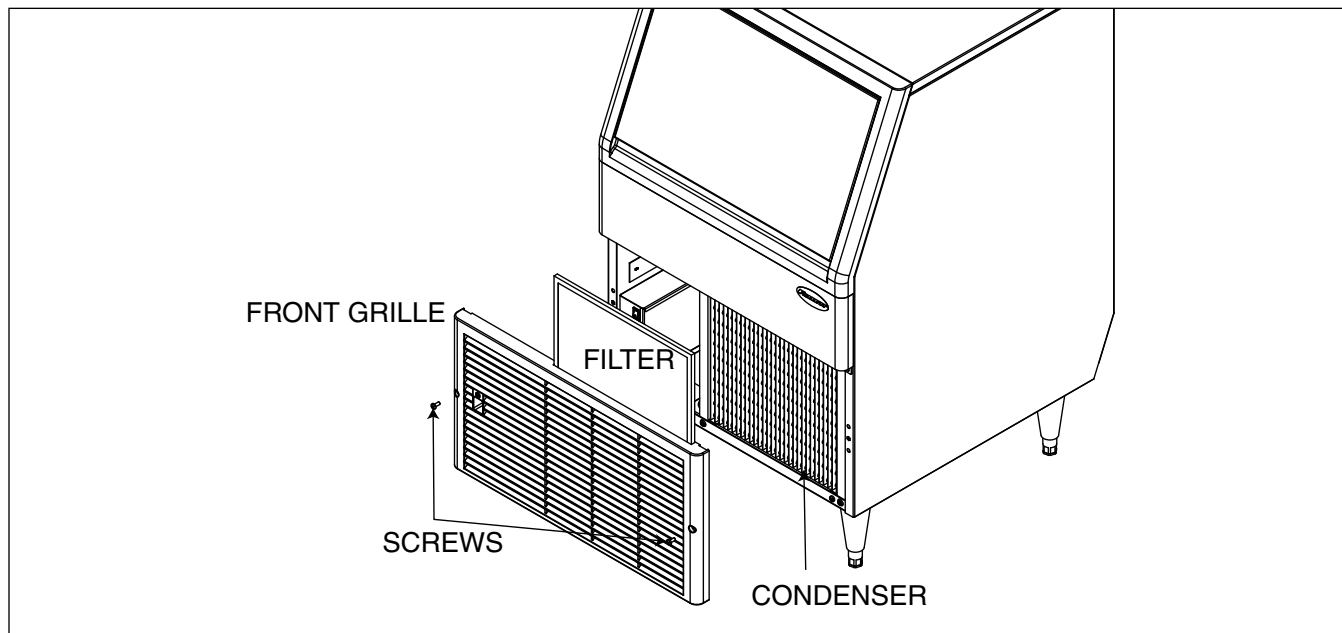

### Cleaning/Descaling and Sanitizing

Cleaning and sanitizing should be performed at least every 6 months (more often if local water conditions dictate). For initial startup, only sanitizing is required.

#### CAUTION!

- For protection, rubber gloves and safety goggles (and/or face shield) should be worn when handling Cleaner or Sanitizer.
- Do not mix Cleaner and Sanitizer together. It is a violation of federal law to use these solutions in a manner inconsistent with their labeling.
- Do not use bleach, it will damage the dispenser.

#### Required Supplies

- (1) x 7 oz. SafeCLEAN™ environmentally-friendly icemaker cleaner packets (00132001)
- Nu-Calgon IMS-II sanitizing concentrate (00979674)
- Funnel and bucket

## Cleaning

1. Remove front grille to access internal components (**Fig. 9**).
2. Press clean switch on the main control box. The **MAINTENANCE** light will turn on and the machine will drain. Wait for the **LOW WATER** light to turn on (**Fig. 10**).
3. Mix 1 gallon (3,8 l) of 100 F (38 C) hot water and 7 oz (198 g), (one packet of Follett SafeCLEAN icemaker cleaner, (00132001).
4. Remove lid from cleaning cup (**Fig. 11**) and fill until cleaning solution completely fills reservoir.
5. Replace lid on cup. **CLEANER FULL** light will turn on (**Fig. 12**) and machine will start cleaning cycle then rinse three times; this process takes approximately 15 minutes.
6. When machine is finished cleaning, the **MAINTENANCE** light will turn off.
7. Remove any remaining cleaner from tube and cleaning cup.

## Sanitizing

8. Press clean switch. The machine will drain and the **MAINTENANCE** light and **LOW WATER** light will turn on (**Fig. 9**).
9. Mix 1 gallon (3,8 l) of 100 F (38 C) hot water and 1.6 oz (48 ml) Nu-Calgon IMS-II Sanitizer (00979674). Place one Sani-Sponge™ in remaining sanitizing solution.
10. Remove lid from cleaning and fill cleaning cup (**Fig. 11**) with sanitizing solution until completely fills the reservoir. Place lid back on cup and replace cup. Save remainder of sanitizing solution.

Fig. 9

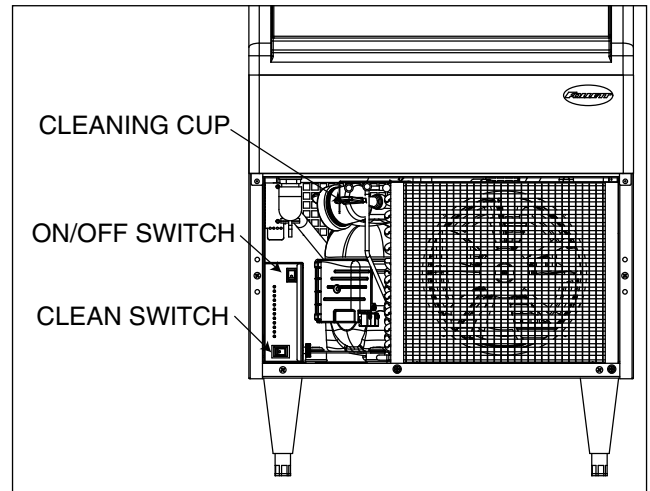

Fig. 10

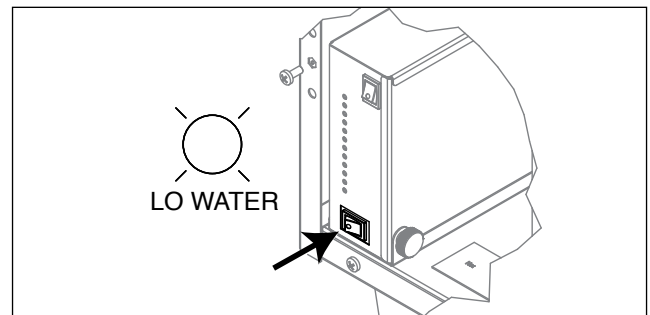
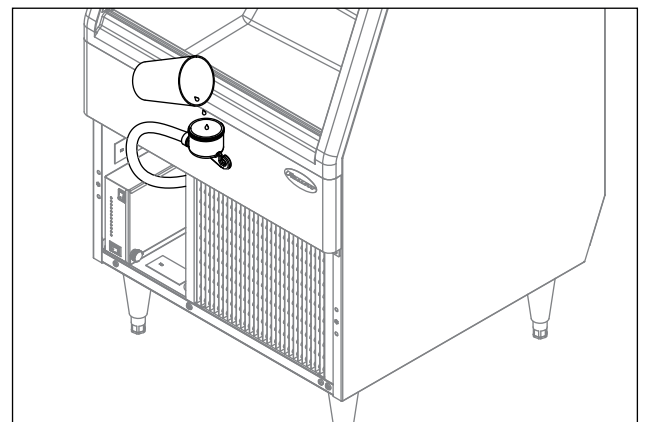
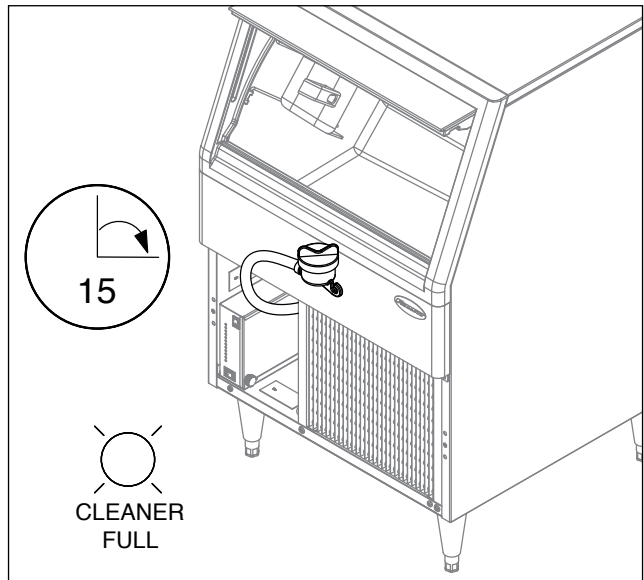

Fig. 11



11. **CLEANER FULL** light will turn on (**Fig. 12**) and machine will start sanitizing cycle then rinse three times; this process takes approximately 15 minutes.
  12. Remove any remaining sanitizer from tube and cleaning cup.
- Note: The next steps must be completed before machine flushes and starts producing ice!**

**Fig. 12**



13. Using disposable food service grade gloves, insert one **dry** Sani-Sponge™ (**Fig. 13.1**). Next, insert one Sani-Sponge soaked in Nu-Calgon IMS-II sanitizer solution (**Fig. 13.2**) (from **Step 9**). Push both of the Sani-Sponges down ice transport tube (ice chute outlet) with supplied pusher tube (**Fig. 13.3**).

**Fig. 13**

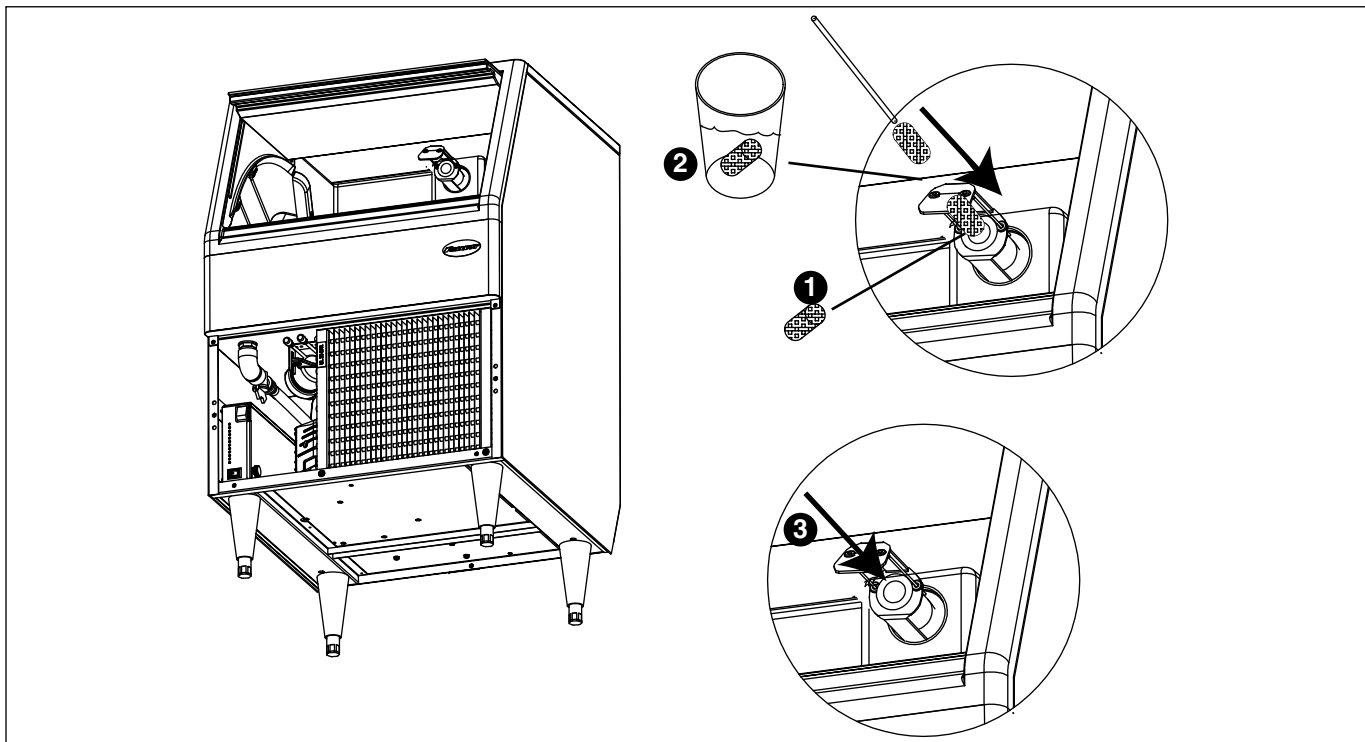

14. Remove and discard pusher tube (Fig. 14).
15. When sanitizing cycle ends, the **MAINTENANCE** light will turn off and machine will start producing the ice. Ice pushes Sani-Sponges through the tube.
16. Place a sanitary (2 gallon or larger) container in bin to collect Sani-Sponges and ice for 10 minutes. Collect 5.5 lbs (3 kg) of ice from unit. Discard ice and Sani-Sponges (Fig. 15).

### Cleaning bin before use and ongoing bin maintenance

Interior of bin must be cleaned and sanitized prior to use and should be cleaned on a routine basis during use.

### Interior bin care

Bin is equipped with polyethylene liner and stainless steel elements that should be cleaned and sanitized periodically with products suitable for use in a food zone. While cleaning and sanitizing the thermostat capillary tube bracket area, use products that are non-aggressive to such materials. After cleaning and sanitizing, rinse thoroughly with potable water.

Fig. 14

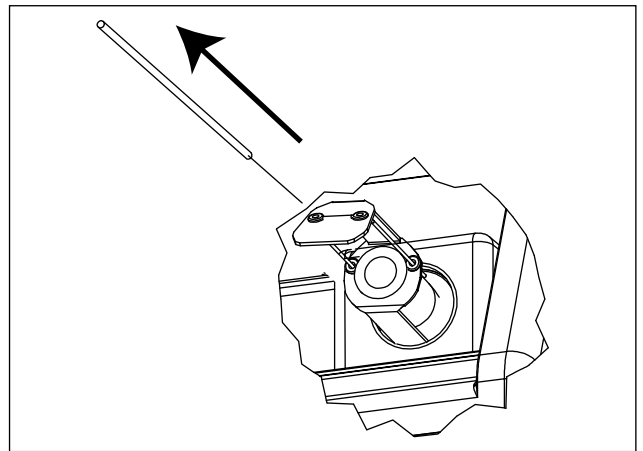
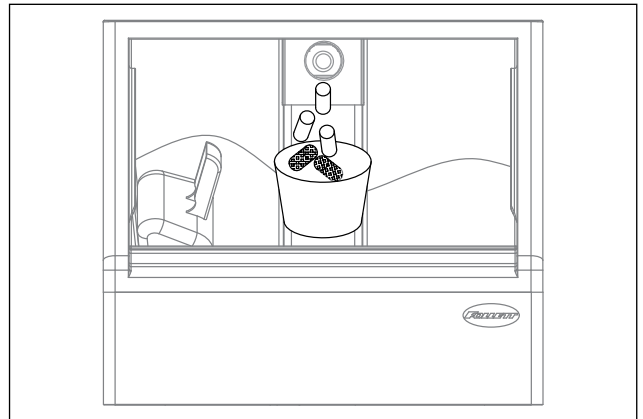

Fig. 15



## Service

### CAUTION!

- No service or maintenance should be performed until the technician has thoroughly read this service manual. Except for routine cleaning and sanitizing, only qualified technicians should attempt to service or maintain this equipment.

## Overview

### How the Machine Works

Follett's automatic-load icemaker is equipped with Follett's 425 lb (193kg)/day ice technology. In the continuous icemaking process, water freezes to the inside wall of the evaporator. A rotating stainless steel auger carries the ice to the top of the evaporator where it is compressed and extruded through an outlet port. The ice is then pushed through a tube to the integrated ice storage bin. When the bin is full, a bin thermostat opens and turn OFF the icemaker.

A solid state control board located in the electrical box of the icemaker controls the normal operation of the icemaker and monitors gearmotor torque. This control board will shut down the icemaker should an overtorque condition occur. It is very important that you familiarize yourself with the operational sequences detailed in this manual before attempting to service the icemaker.

Ice enters the integrated ice bin. Using the scoop supplied with the unit, you can easily take the ice out of the bin. There is a scoop holder located on the internal wall. When ice is emptied from the ice bin, the thermostat capillary tube gets warm and signals the machine to produce ice. There is no need turn off the machine during its normal operation.

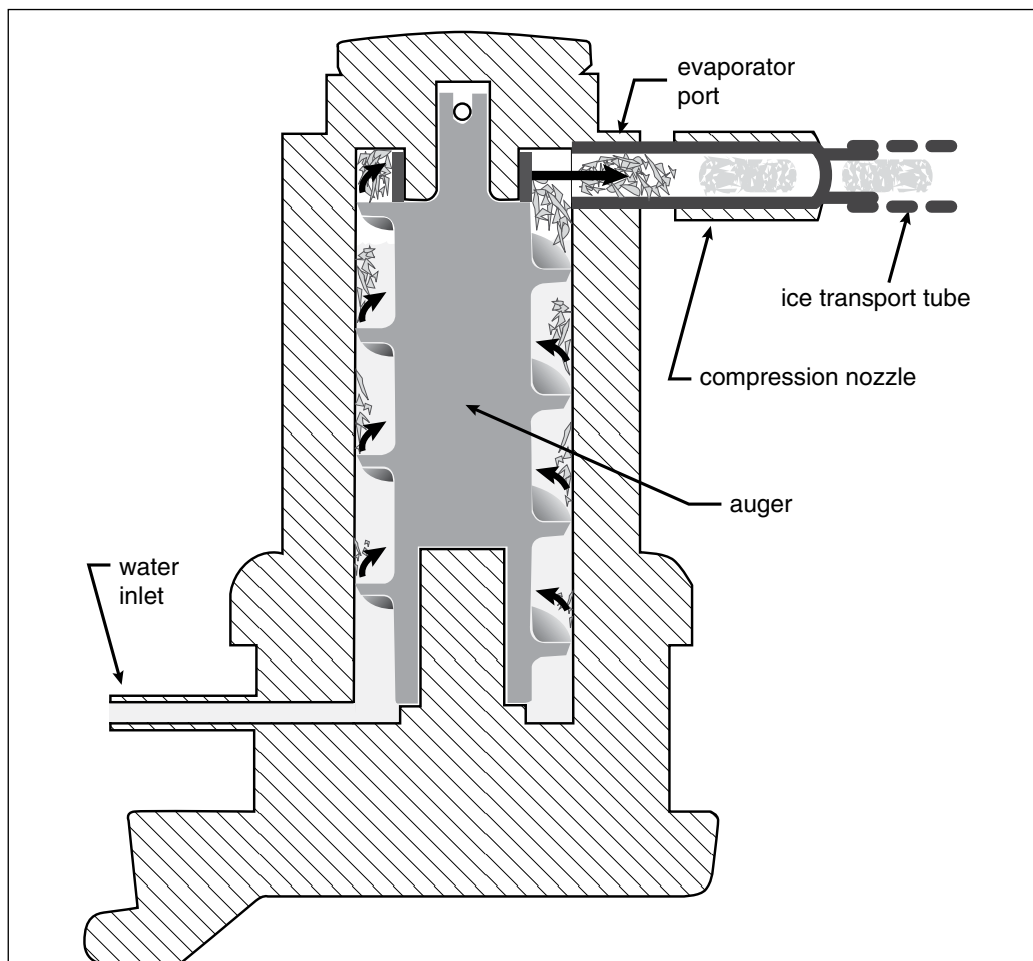



## Accessing Internal Components

### CAUTION!

- Except for routine cleaning and sanitizing, only qualified technicians should attempt to service or maintain this equipment.
- Use caution when sliding out the bin.

### Ice Bin Removal

1. Empty all the ice from the bin.
2. Remove the front grille (**Fig. 16.1**).
3. Remove two screws behind the grille (**Fig. 16.2**).
4. Shut off the bin drain valve and remove the drain tube from the ice bin (**Fig. 17**).
5. Facing the unit, slide the bin out by pulling it towards you.

Fig. 16

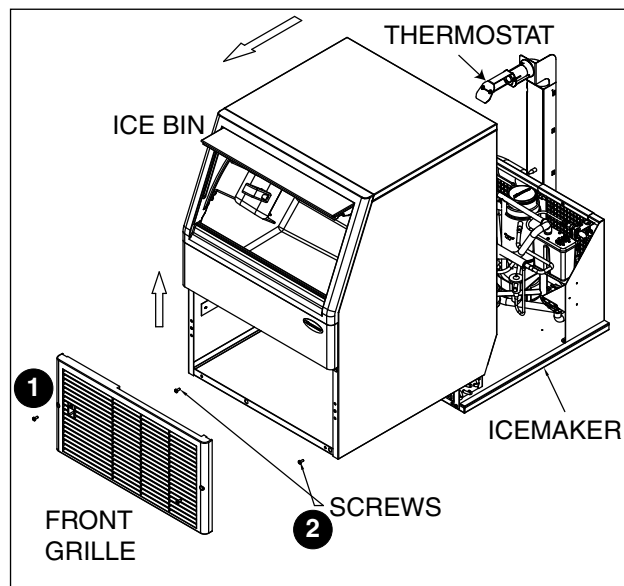
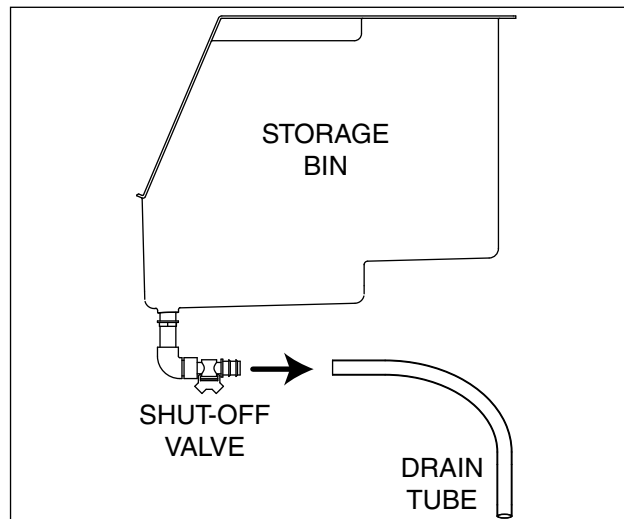

Fig. 17



## Water System

The water level in the evaporator is controlled by a feed solenoid and level detecting sensors. Referencing the diagram below, water sensing rods extend down into the reservoir. The system works via electrical conductivity as follows:

One of the longest probes is a Common. When water is between any of the other probes and the common, the PC board will sense the activation. During normal operation, the water level rises and falls between the Normal High and Normal Low sensors. As water is consumed to make ice, the water level will fall until the Normal Low sensor is exposed, triggering the water feed solenoid to turn on. Water will fill until the Normal High sensor is activated.

**Note: The potable water dissolved solids content must be greater than 10 ppm for the water control system to function properly. If using a reverse osmosis water filtration system, ensure TDS (total dissolved solids) level is greater than 10 ppm.**

Fig. 18

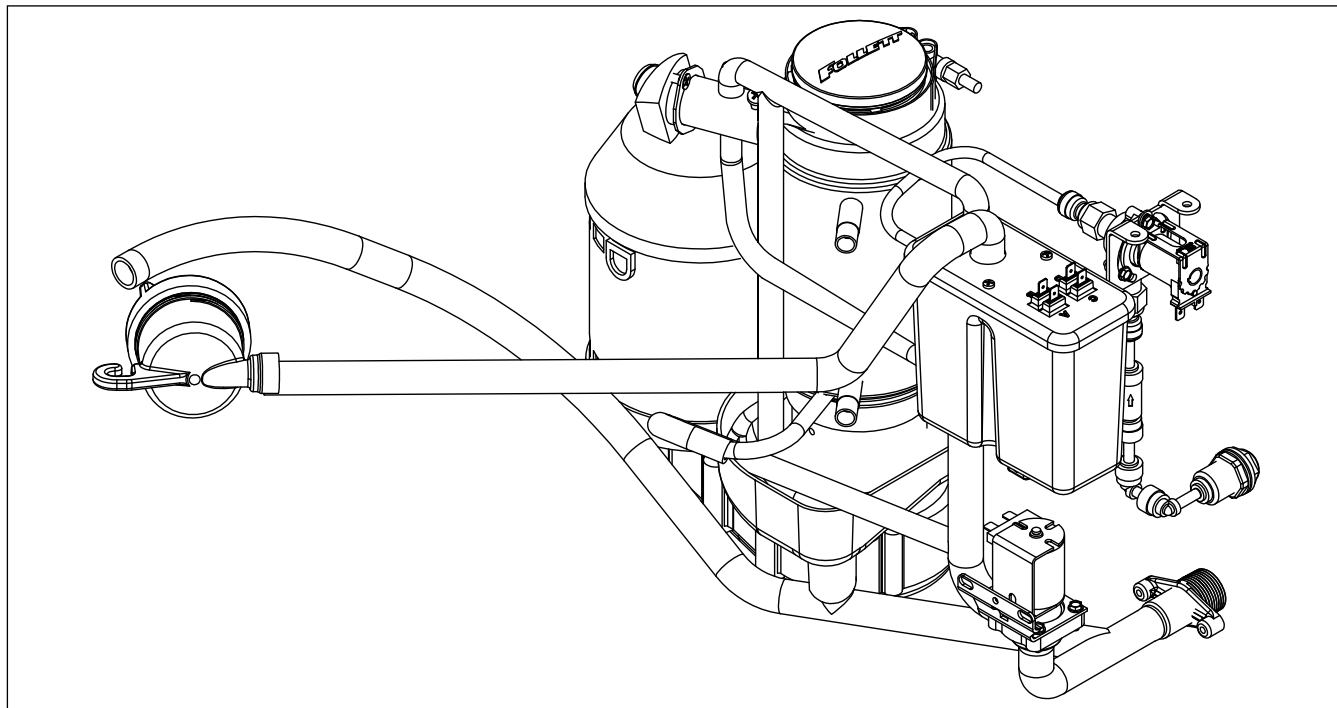

Fig. 19 - Water Reservoir

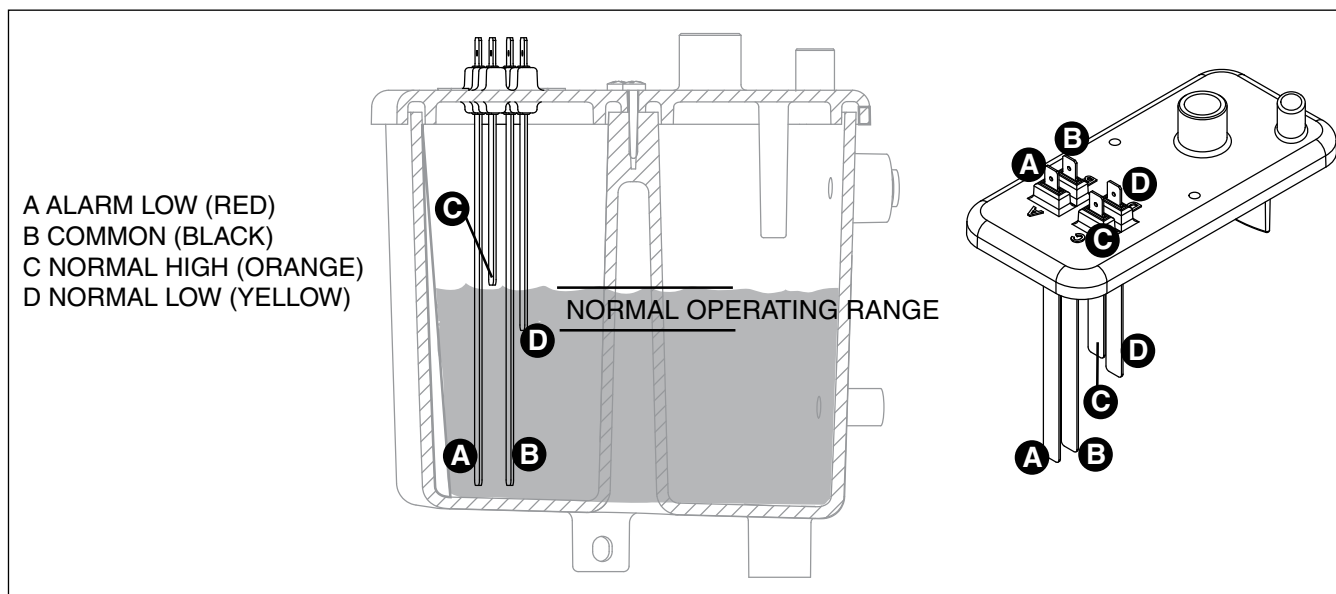
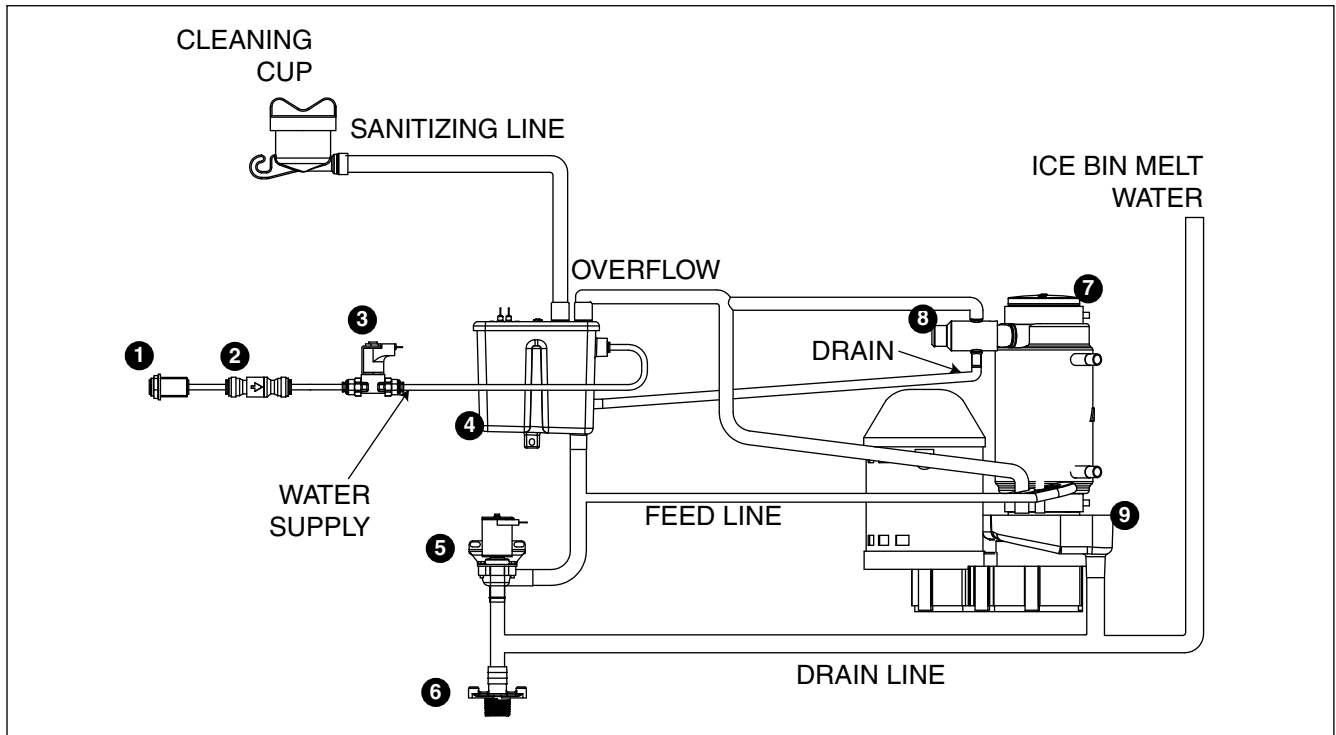

Fig. 20



- |                             |                                     |
|-----------------------------|-------------------------------------|
| 1 Push in water inlet 3/8"  | 6 Drain outlet 3/4"                 |
| 2 Check valve               | 7 Evaporator and gearmotor assembly |
| 3 Water feed solenoid valve | 8 Ice compression nozzle            |
| 4 Water reservoir           | 9 Drain pan                         |
| 5 Purge valve               |                                     |

# Electrical System

## ATTENTION!

To prevent circuit breaker overload, wait 15 minutes before restarting this unit. This allows the compressor to equalize and the evaporator to thaw.

### Normal Control Board Operation

The PC board indicator lights provide all the information necessary to determine the machine's status. Green indicator lights generally represent "go" or normal operation; Yellow indicators represent normal off conditions; Red indicators generally represent alarm conditions, some of which will lock the machine OFF.

A flashing green light labeled POWER indicates power to the machine. All other normal operation status indicators are covered as follows:

Icemaker disposition	Operating conditions
<b>Legend:</b> ● ON    ○ OFF    ◐ ON or OFF    ◑ FLASHING	
1. Icemaker is making ice.  CLEANER FULL ○ NOT USED ○ HI PRESS ○ HI AMPS ○ SERVICE ○ MAINT/CLEAN ○ LOW WATER ○ TIME DELAY ○ SLEEP CYCLE ○ MAKING ICE ● LOW BIN ● POWER ON ◑	1. <b>Normal running.</b>
2. Icemaker is not making ice.  CLEANER FULL ○ NOT USED ○ HI PRESS ○ HI AMPS ○ SERVICE ○ MAINT/CLEAN ○ LOW WATER ○ TIME DELAY ● SLEEP CYCLE ○ MAKING ICE ○ LOW BIN ◐ POWER ON ◑	2. <b>Normal time delay.</b> When the bin fills with ice, the <b>LOW BIN</b> light goes out momentarily and the refrigeration and auger drive systems immediately shut down. ( <b>Note:</b> The fan motor will continue to run for 10 minutes to cool condenser). The <b>TIME DELAY</b> LED lights, initiating the time delay period. When the time delay expires, the machine will restart as long as the <b>LOW BIN</b> light is on.

### **Error Faults:**

The PC board monitors various operating parameters including high pressure, auger gearmotor amperage limits, and low water alarm conditions. There are two types of errors namely "hard" or "soft". A hard error is one that shuts the machine off and will not allow restart until the reset button is pressed. Even cycling power will not reset a hard error.

A soft error can either be automatically reset should the condition rectify, or if power is cycled. Should an error occur, consult the troubleshooting guide in this manual or a Follett service technician.

### **Soft Errors:**

**HI AMPS:** The PC board monitors the amperage of the auger motor. Should the gear motor experience current draw above the allowable limit, the machine will shut down and the **TIME DELAY** and **HI AMP** will be illuminated. After the time delay, the machine will restart and the **TIME DELAY** and **HI AMP** will clear. HI AMPS will also occur if the PC board detects no gear motor amperage (0A - gear motor disconnected).

**LO WATER:** During operation, the water level cycles between the normal low and normal high sensors. Should the water be shut off to a running machine, a soft error will occur. The error sequence is as follows: During operation, the water level falls to the normal low sensor, and when it does the water feed solenoid is energized. If water is not detected at the normal low sensor within 10 seconds, a soft error will occur. The machine will shut down, but the water feed solenoid will remain energized. Should water return, it will fill to the normal low sensor and the machine will resume normal operation. The error will clear automatically.

**HI PRESSURE:** Should the refrigeration pressure rise above 425 psi, the machine will shut down and the **TIME DELAY** and **HIGH PRESSURE** will be illuminated. After the time delay, and if the pressure has fallen back below the reset point of 295 psi, the machine will restart and the **TIME DELAY** and **HIGH PRESSURE** will clear.

### **Hard Error:**

**HI AMPS:** If a second hi-amp error occurs within 1 hour of the initial hi-amp error, the icemaker will shut off and the reset on the board must be pressed to clear the error. If a second hi-amp has occurred, the **HI AMP** LED only will be illuminated.

### **Relay/triac Output Indication:**

Each relay on the board has an indicator light associated with its output. For example, when the relay for the water feed solenoid is energized, the adjacent indicator light glows green.

### **Flushing Logic:**

**Off cycle:** At the completion of off-cycle time delay, the machine checks for a cumulative one (1) hour of ice making time since the last off-cycle flush. If the cumulative ice making time exceeds one (1) hour, the machine will open the drain valve for 60 seconds to drain the evaporator in its entirety. It will then refill with water and begin making ice. If the ice making time is less than 1 hour, the machine will start and begin making ice without draining the evaporator.

# Starting Procedure

## Normal Operation – Stage 1

Power is supplied to L1 of the control board, the **POWER** LED light begins flashing. The ice level bin thermostat in the dispenser is closed and calling for ice, supplying contact closure to the control board. The **LOW BIN** LED will be lit. The control board will now go through the start-up sequence. The board checks the water sensors (located in the reservoir) for continuity between the common probe (B) and the high probe (C). If continuity is not sensed, the water fill valve (P21) is energized.

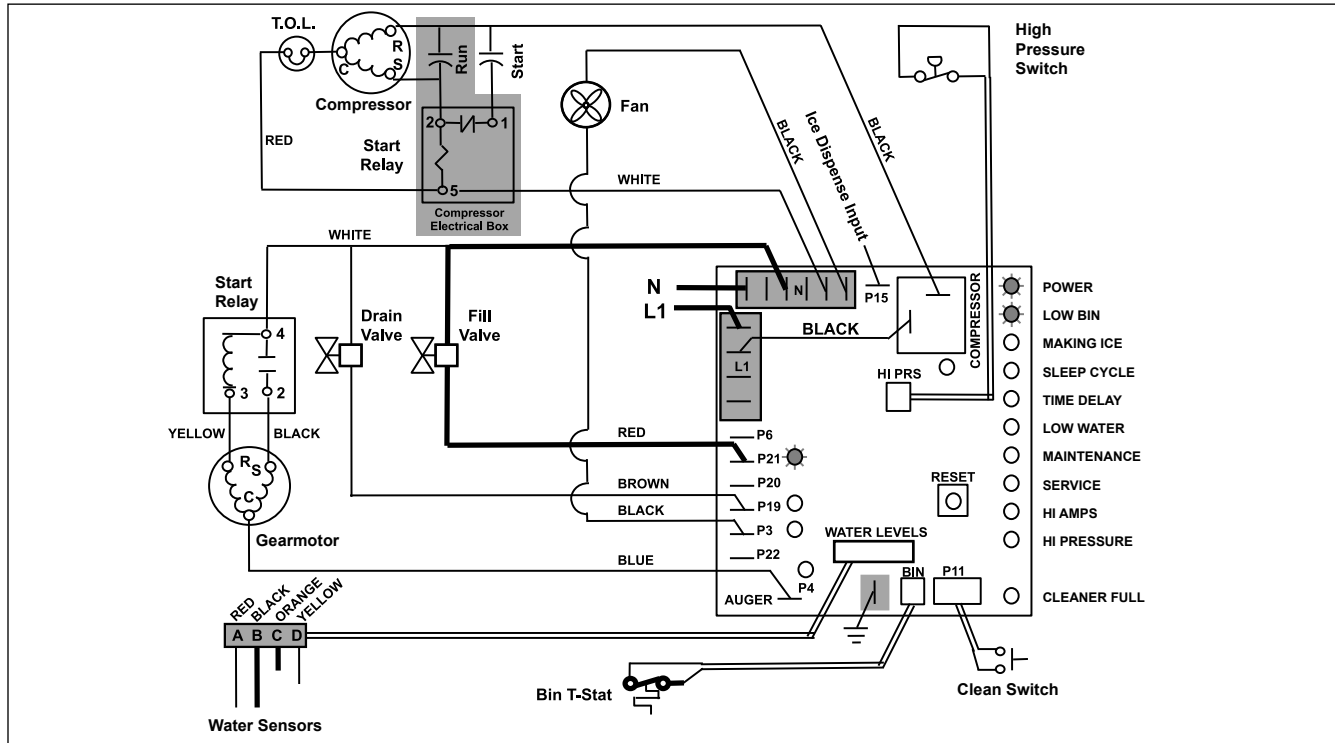

## Normal Operation – Stage 2

When continuity is seen between B and C, the water valve de-energizes, the AUGER output (P4) comes on along with the **MAKING ICE** LED. The auger gearmotor's start windings are energized through a current style start relay that is pulled in by the initial high current draw of the gearmotor.

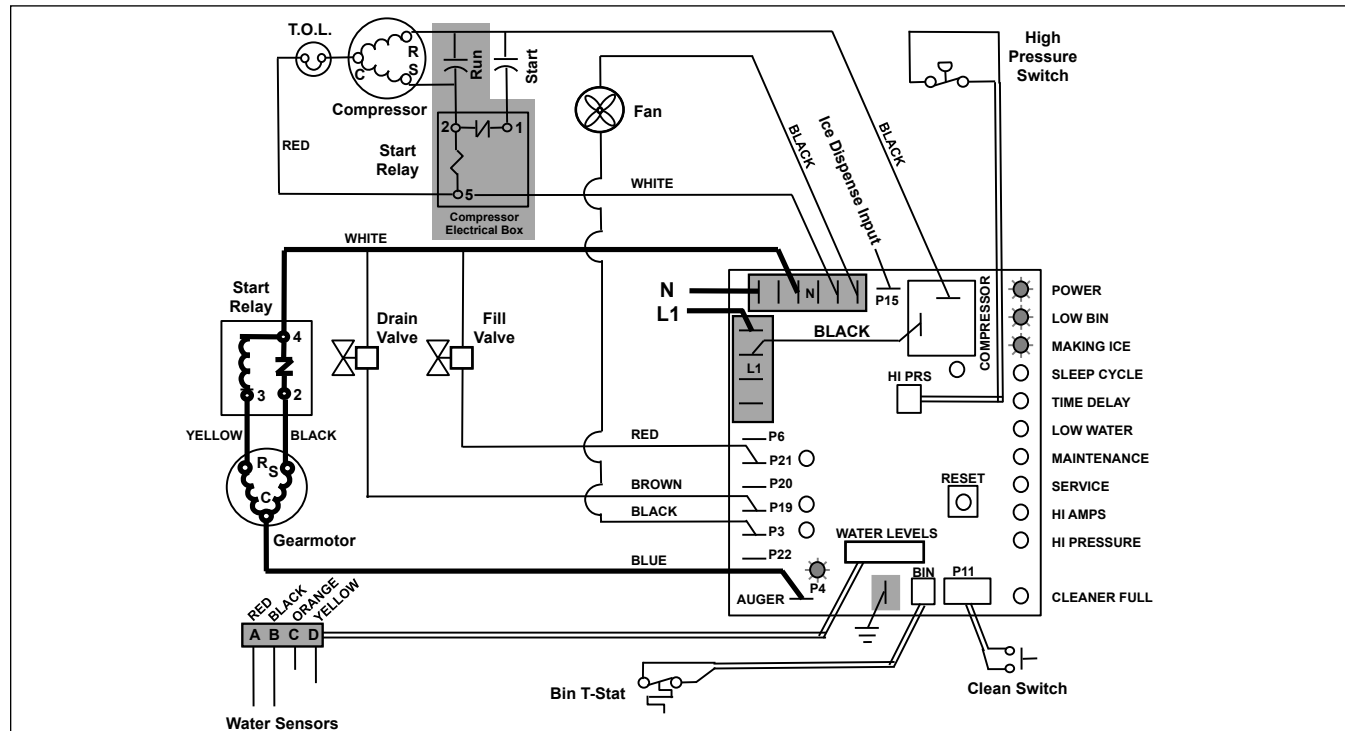

### Normal Operation – Stage 3

After the initial high current draw drops off, the gearmotor start relay contacts open, dropping out the start winding. The condenser fan output (P3) comes on 0.5 seconds later.

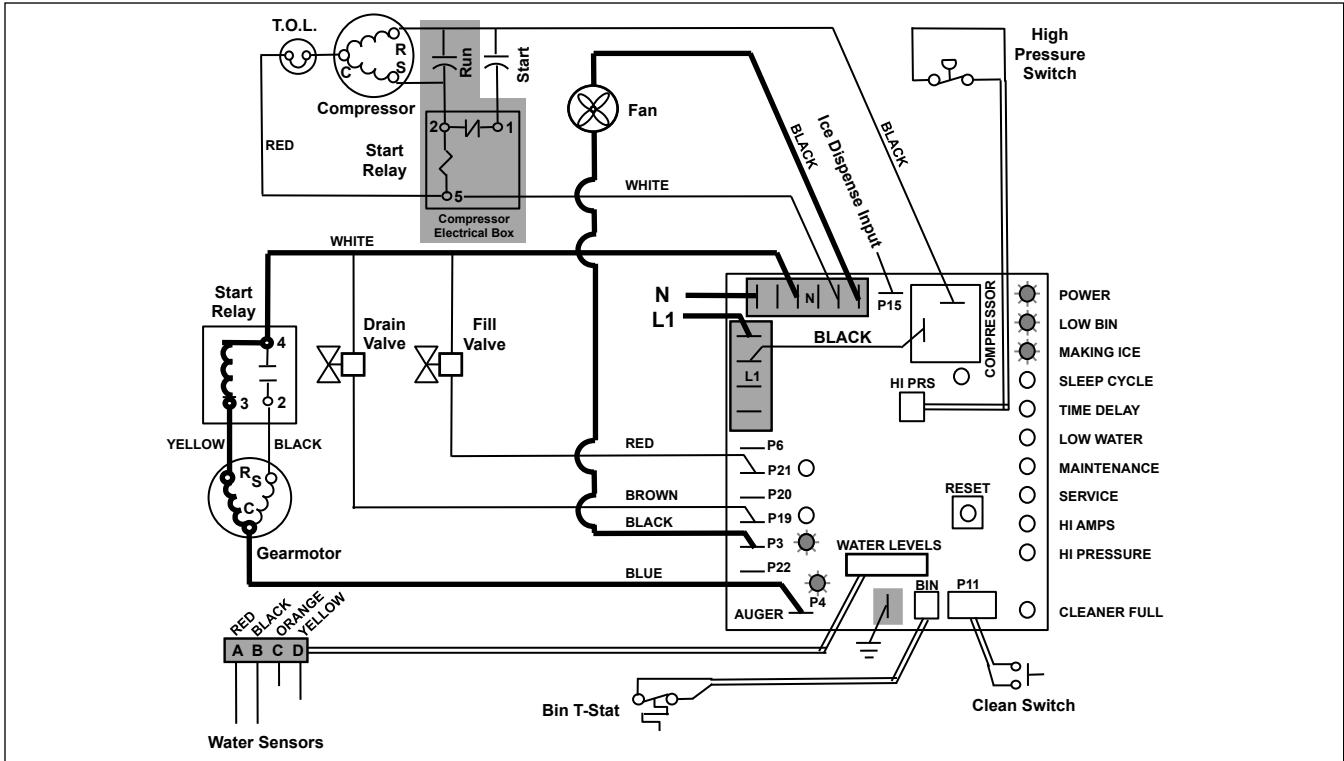

### Normal Operation – Stage 4

One second (1 s) after the fan comes on, the **COMPRESSOR** output comes on. The compressor circuit uses both run and start capacitors along with a potential start relay. The start capacitor is energized through the normally closed contacts of the start relay.

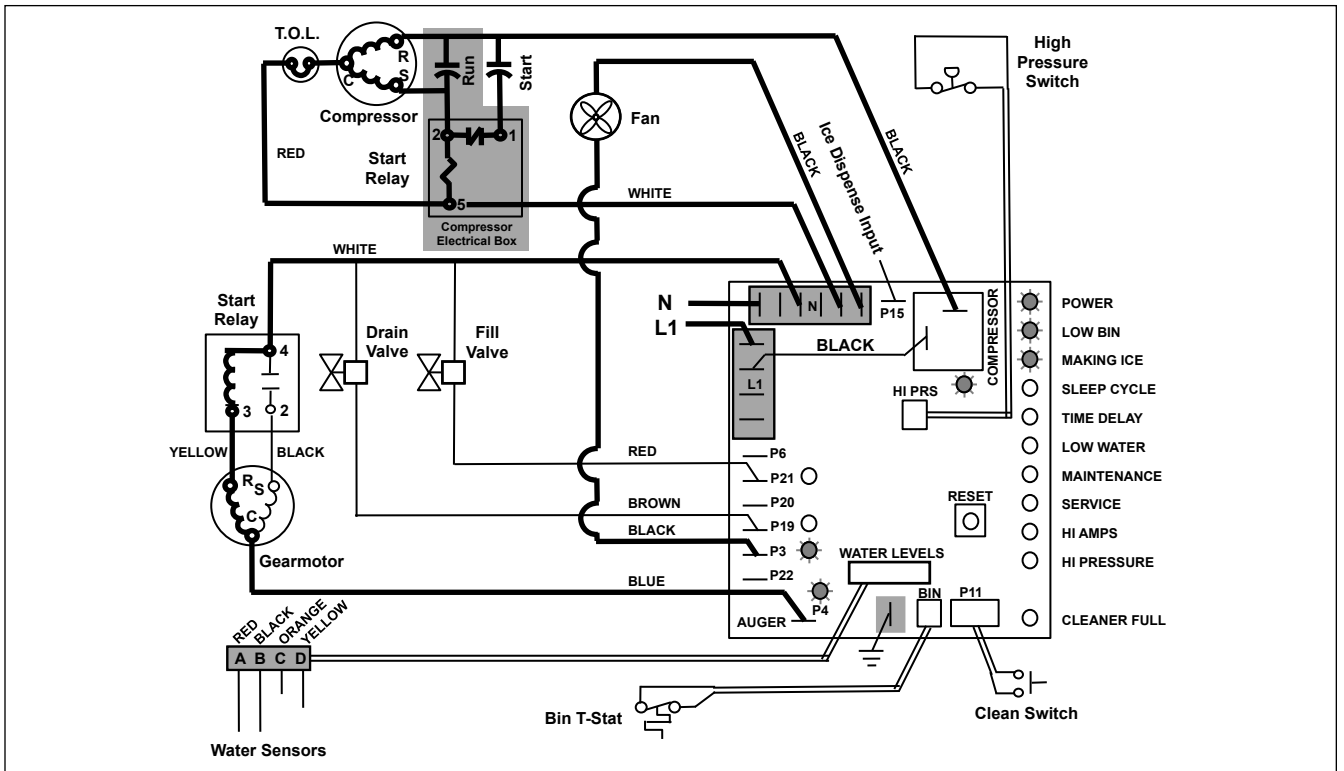

### Normal Operation – Stage 5

As the compressor comes up to normal running speed, its start winding generates a voltage potential across the relay's coil. This energizes the coil to open the contact and drop out the start capacitor.

The icemaker is now in a normal ice making mode. The icemaker will produce ice until the bin level control in the ice dispenser is satisfied.

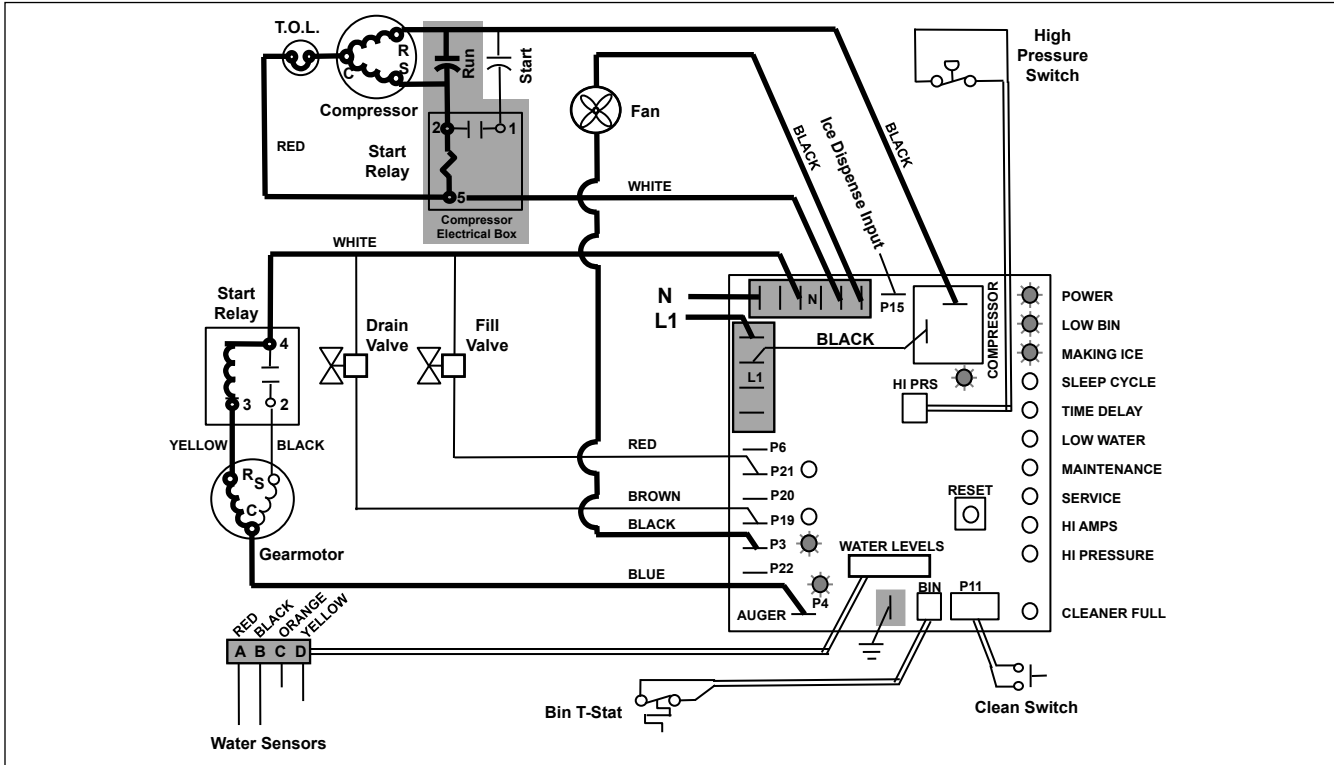

### Normal Operation – Stage 6

Once the bin thermostat control opens, the **LOW BIN** LED goes out. After a 10 second delay the compressor output turns off, the **MAKING ICE** LED goes out and the **TIME DELAY** LED comes on.

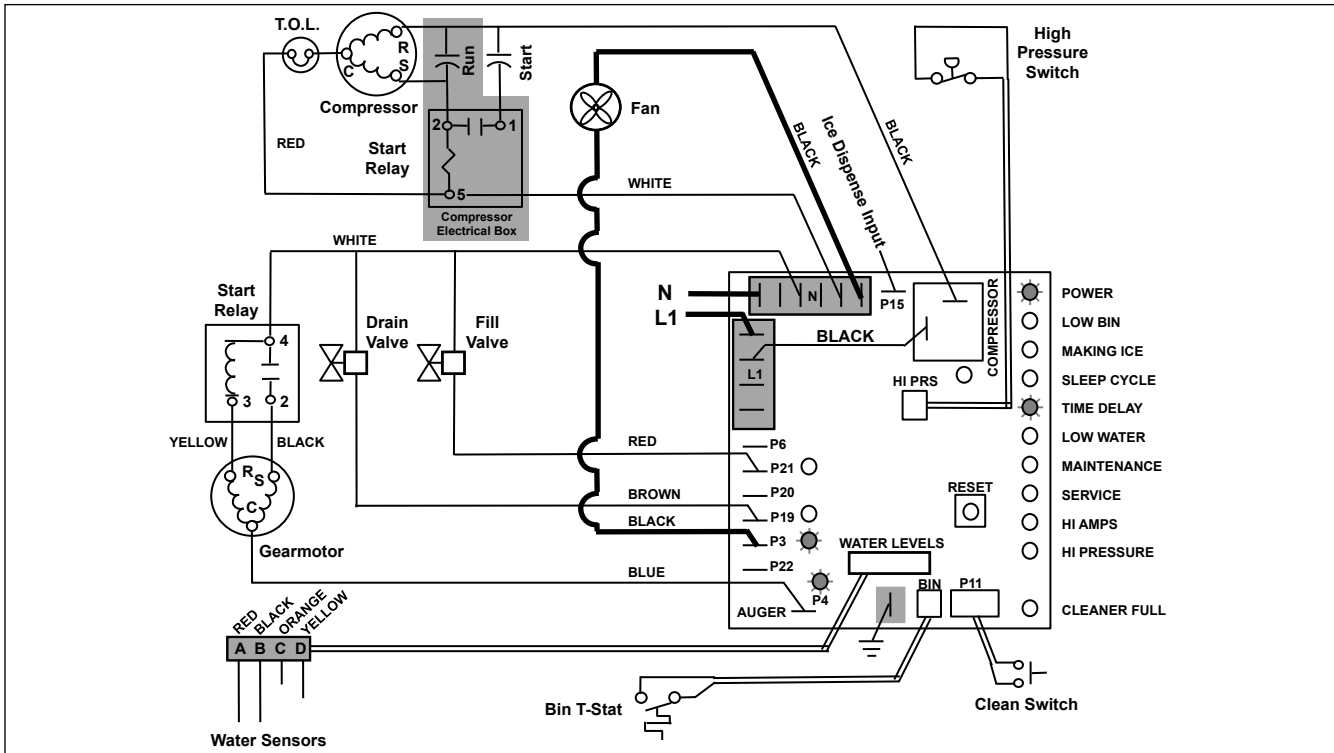



### Normal Operation – Stage 7

The fan motor continues for 10 minutes before shutting off. The **TIME DELAY** LED remains on for 20 minutes. The icemaker will not start while the **TIME DELAY** LED is on. To restart the icemaker for troubleshooting purposes, depress the reset button to clear the control board.

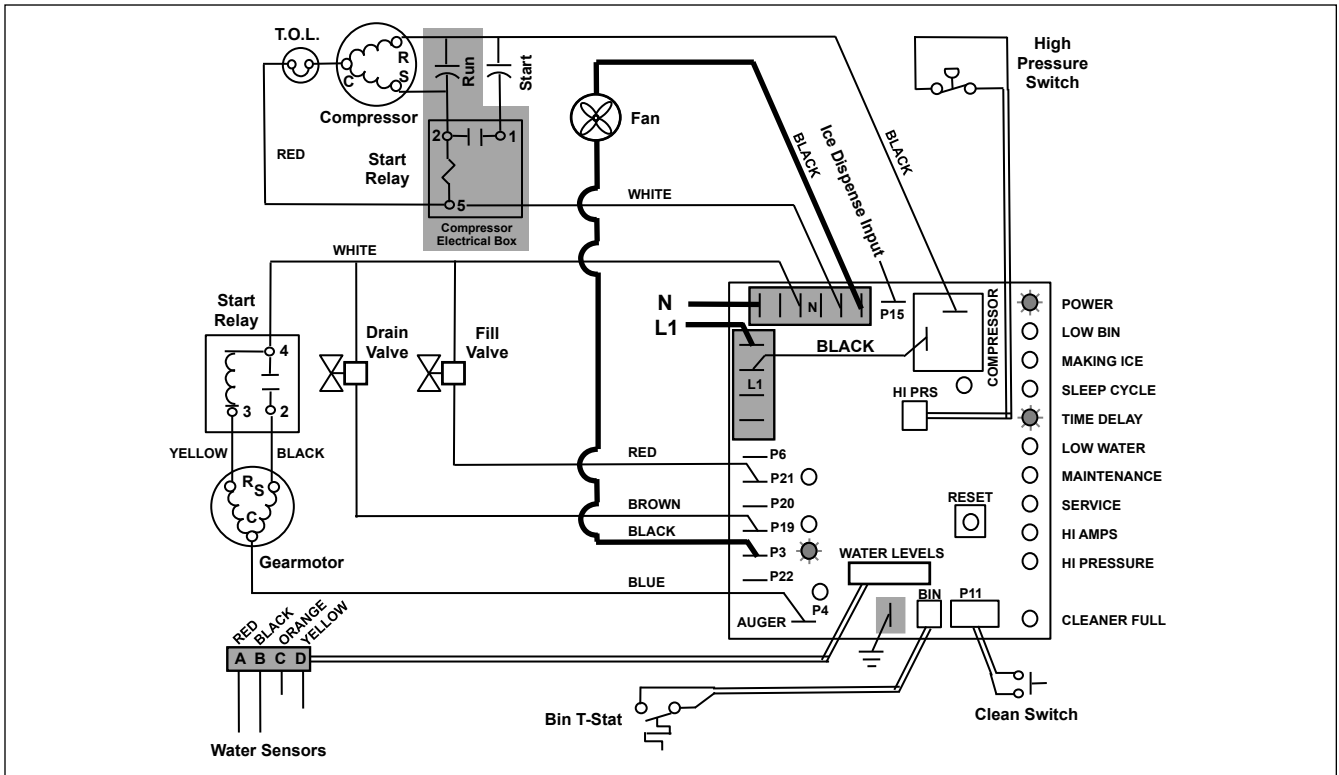

### Normal Operation – Stage 8

When the dwell time of 20 minutes has expired, the **TIME DELAY** LED goes off. If 5 seconds of ice has been dispensed and the **SLEEP CYCLE** LED is off, the icemaker will go through the normal start-up sequence when the bin level control signals the control board for ice.

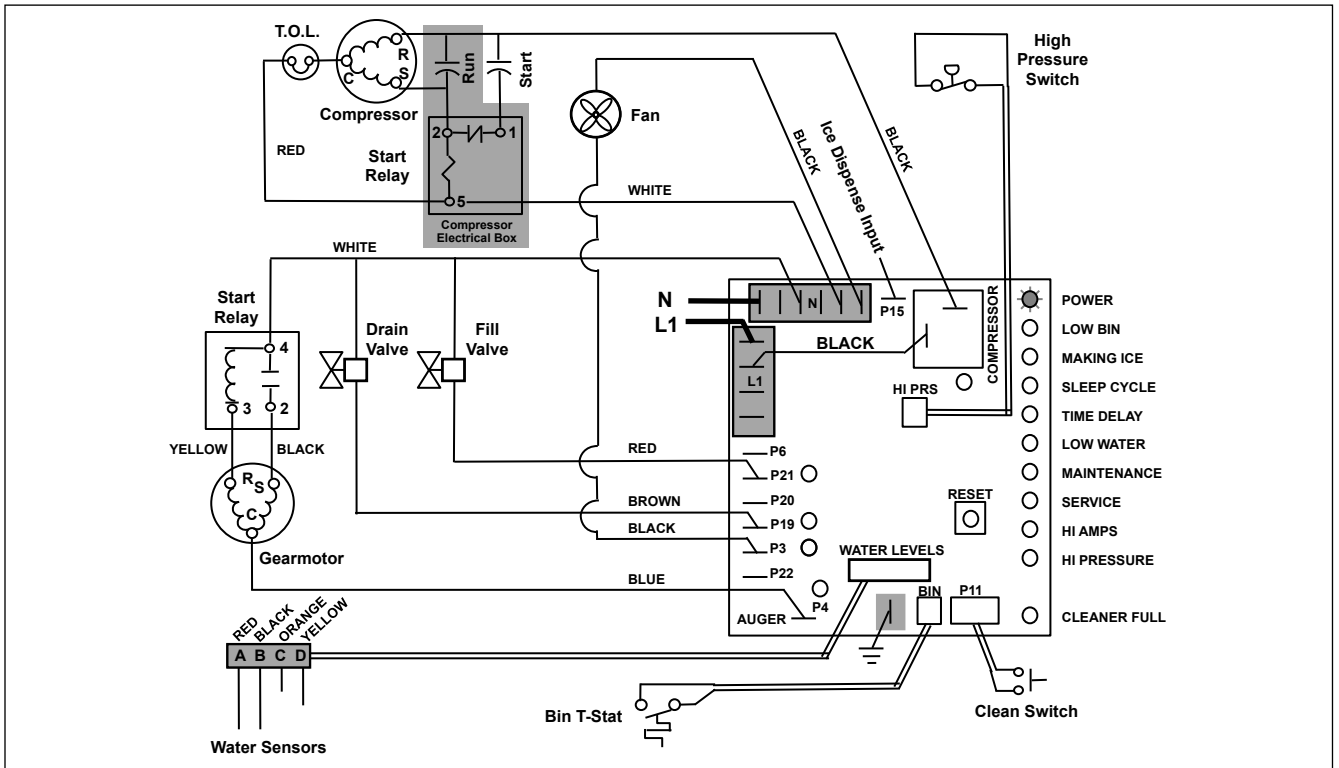

## Self-flushing

At the completion of the 20 minute time delay, the machine checks for a cumulative one hour of ice making time since the last off-cycle flush. If the cumulative ice making time exceeds one hour, the machine will energize the drain valve P19 for 60 seconds to drain the evaporator. It will then refill with water, flush again, refill and begin making ice if the **LOW BIN** LED is on. If the ice making time is less than 1 hour, the machine will start and begin making ice without draining the evaporator.

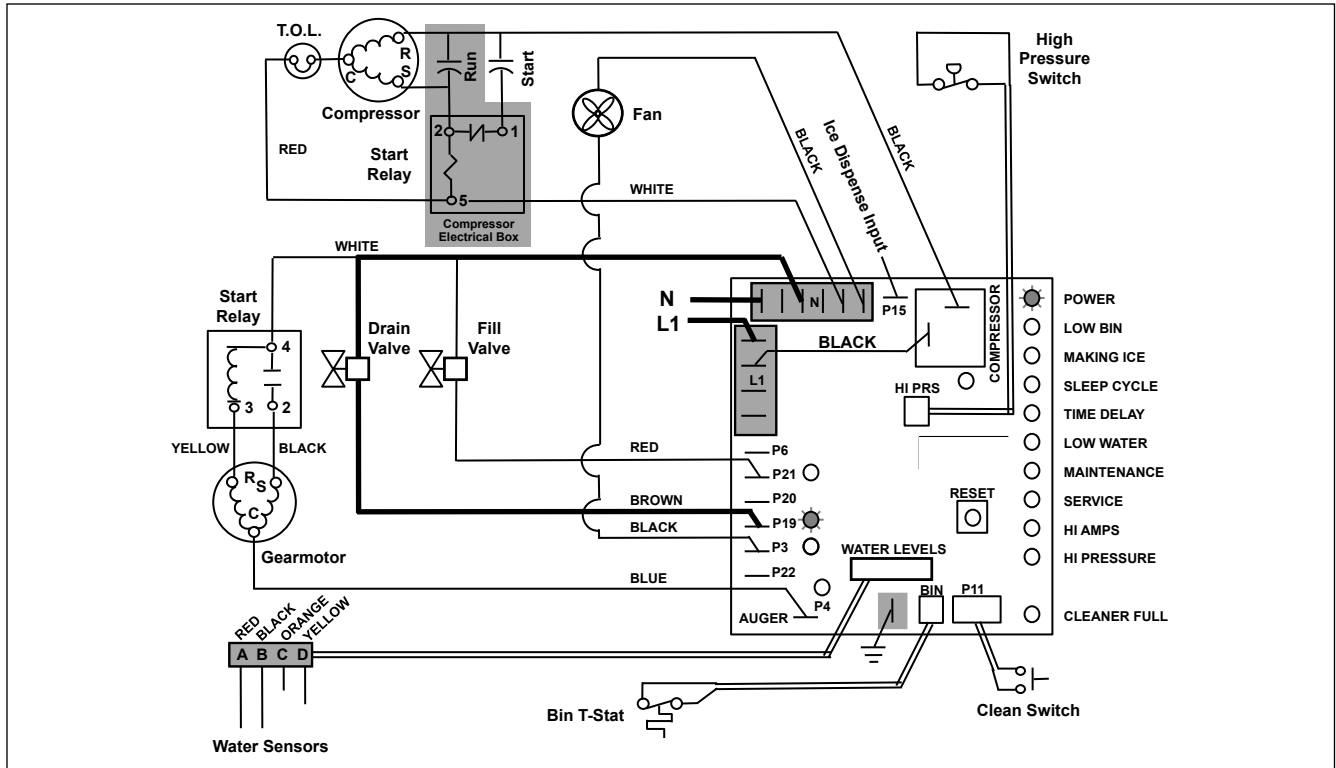

# Diagnostic Stages

## High Gearmotor Amps – Stage 1

The **HI AMPS** error and **TIME DELAY** LEDs are on indicating that the control board has sensed an over-torque condition at the P4 terminal (more than 3A from the gearmotor) and shut the icemaker down (strike one). The **HI AMPS** and **TIME DELAY** LEDs will remain on for 60 minutes after an over-torque condition has occurred. The icemaker will remain off as long as these two LED lights turn off, and the control board will try to go through a normal start-up sequence.

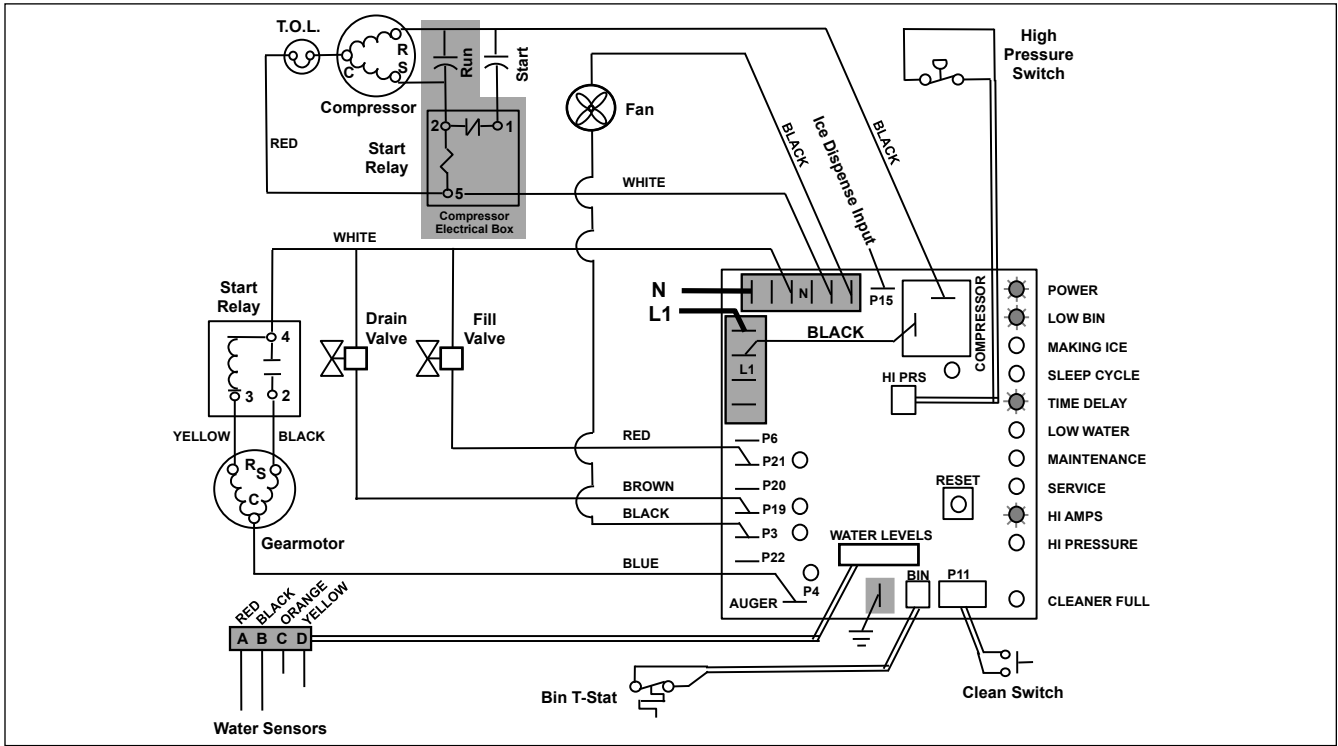

## High Gearmotor Amps – Stage 2

If the restart is successful the board will continue to monitor the current draw on P4 for 60 minutes looking for a second high amps (above 3A) occurrence. If the icemaker runs without problems for 60 minutes and no additional torque errors occur, the icemaker will continue normal operation.

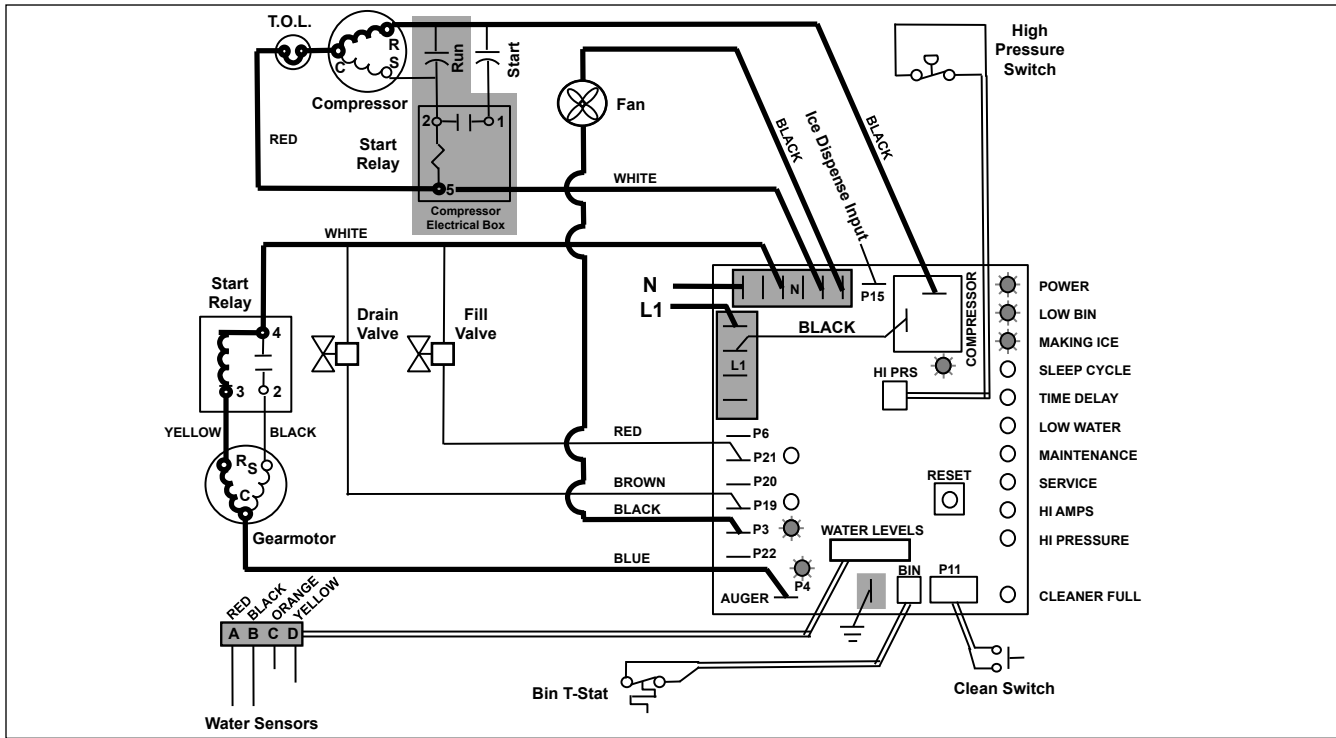

## High Gearmotor Amps – Stage 3

If a second occurrence happens during the 60 minute monitoring period, the **HI AMPS** LED will come on again and shut the machine down (strike two). The **HI AMPS** LED (without the **TIME DELAY** LED) will indicate to the technician that two consecutive over-torque situations have occurred. The icemaker is shut down at this time and locked out. It will not restart unless the manual reset button is depressed while power is on.

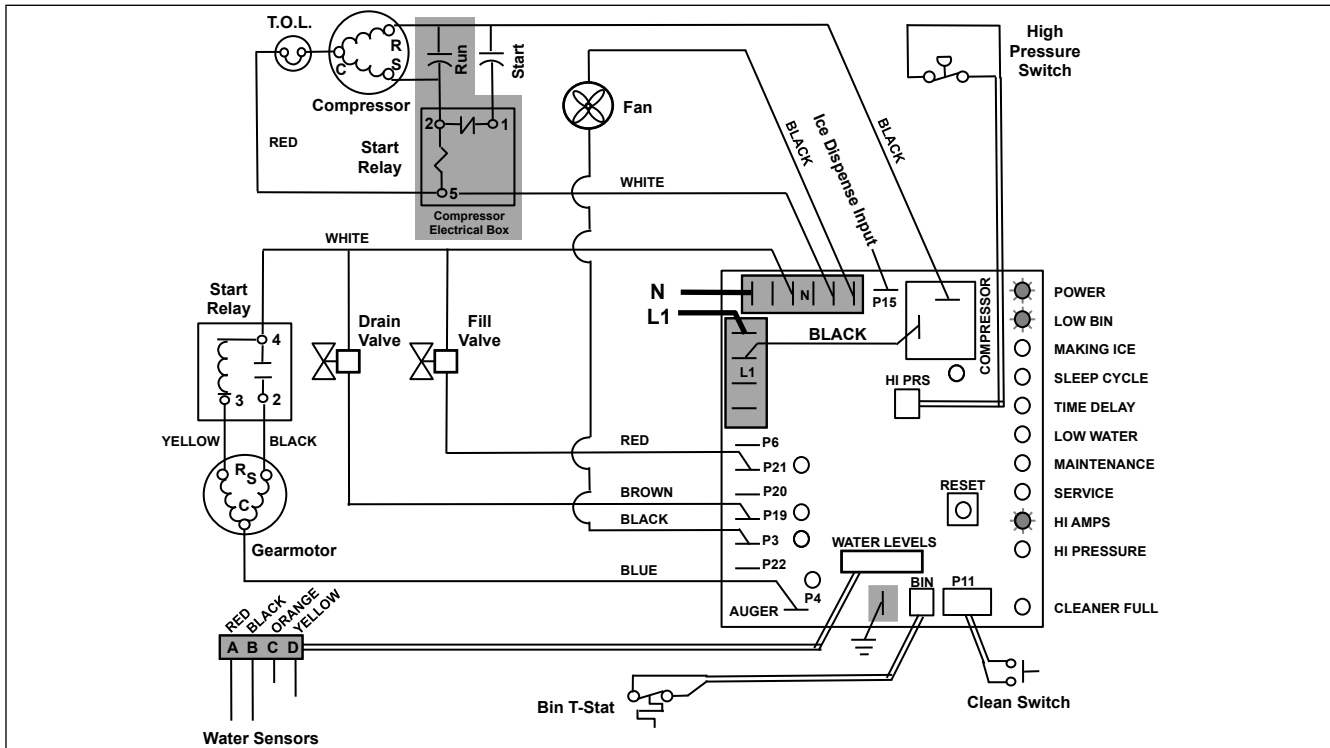

## Loss of Water

During operation, the water level cycles between the normal low (D) and normal high (C) water probes - the fill valve (P21) cycling on and off. If continuity is not detected between the common probe (B) and normal low (D) within 10 seconds, the **LOW WATER** and **TIME DELAY** LEDs will come on and the machine will shut down for the one hour time delay period. After the time delay, the fill valve will re-energize and wait for continuity between the common probe and normal high before restarting. **LOW WATER** LED will remain on until the water level is satisfied.

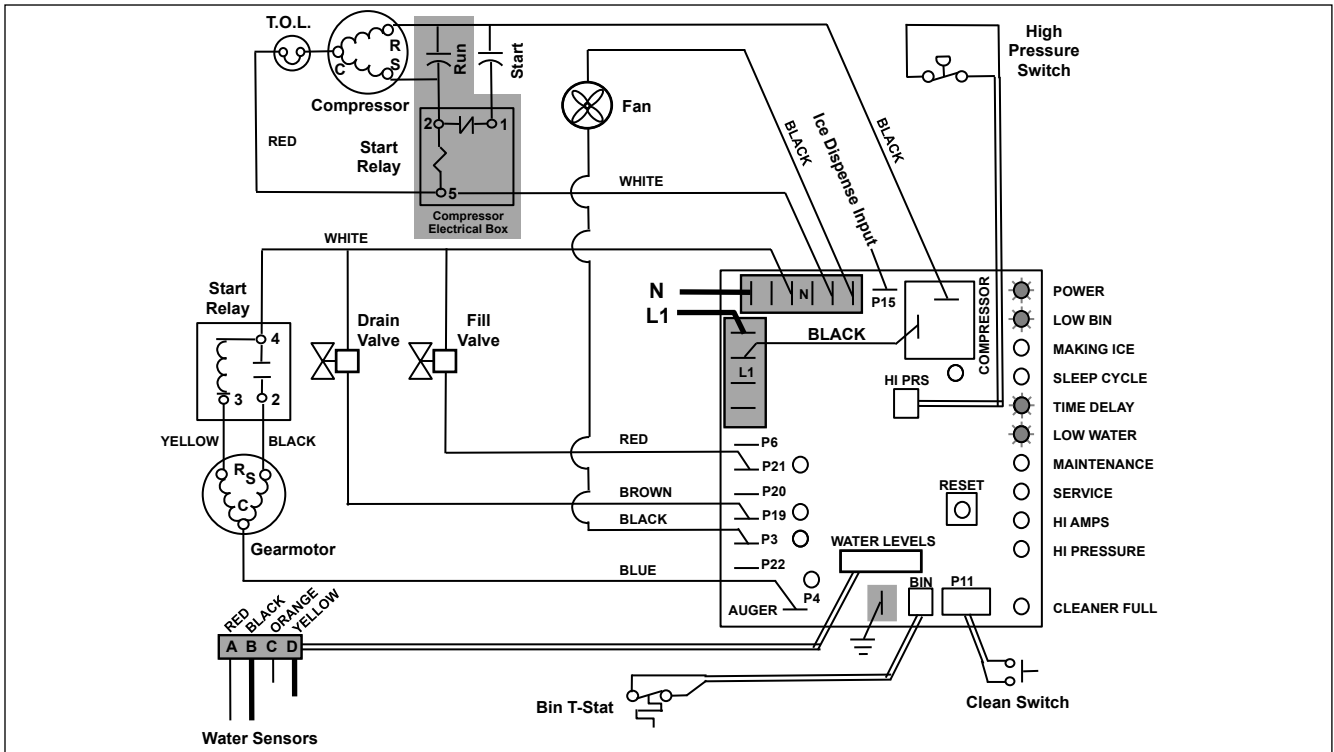

## High Refrigerant Pressure

Should the refrigeration pressure rise above 425 psi, the high pressure switch contacts will open. The board sees the open circuit and the **HIGH PRESSURE** and **TIME DELAY** LEDs will come on, the machine shuts down. After the one hour time delay, the machine will attempt to restart. If the pressure has fallen below the reset point of 295 psi and the board see the contacts closed, the machine will resume normal operation. If the contacts are still open after the restart, the board will again go into **HIGH PRESSURE** and **TIME DELAY**, cycling until contact closure is seen.

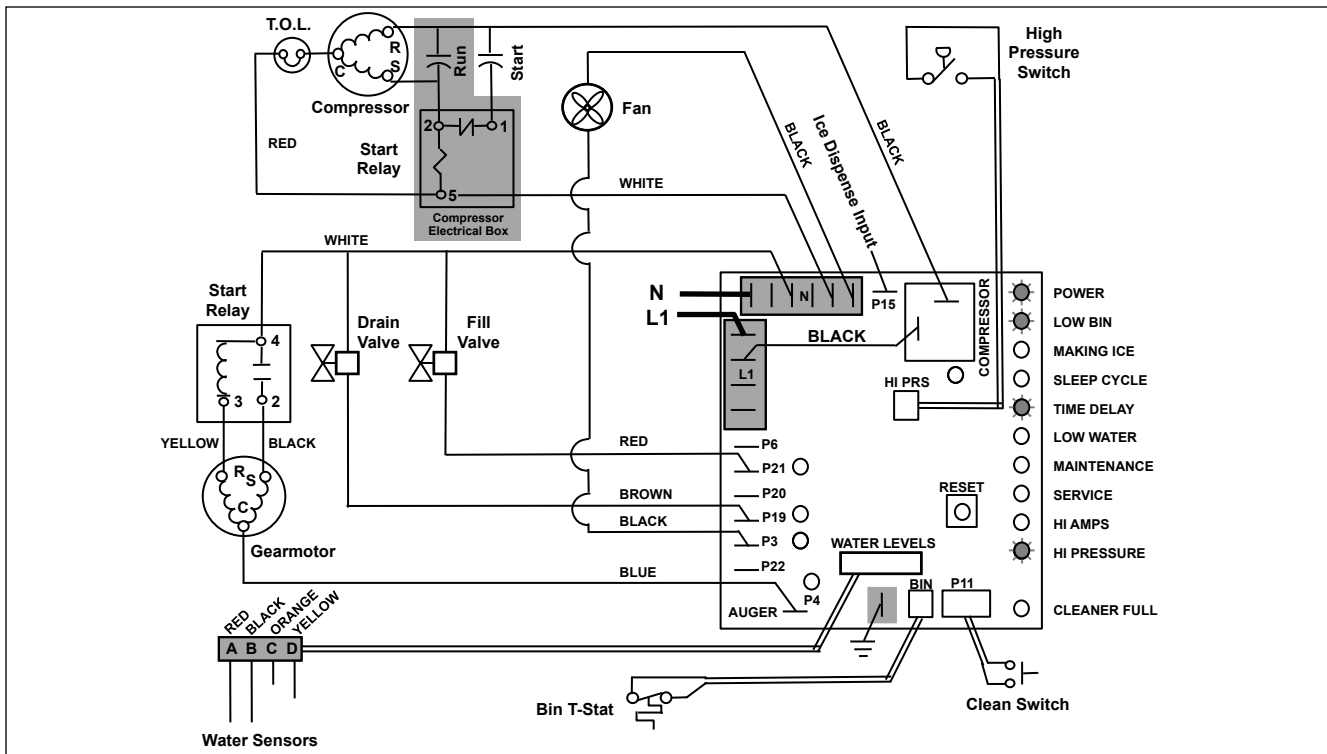

# Wiring Diagram

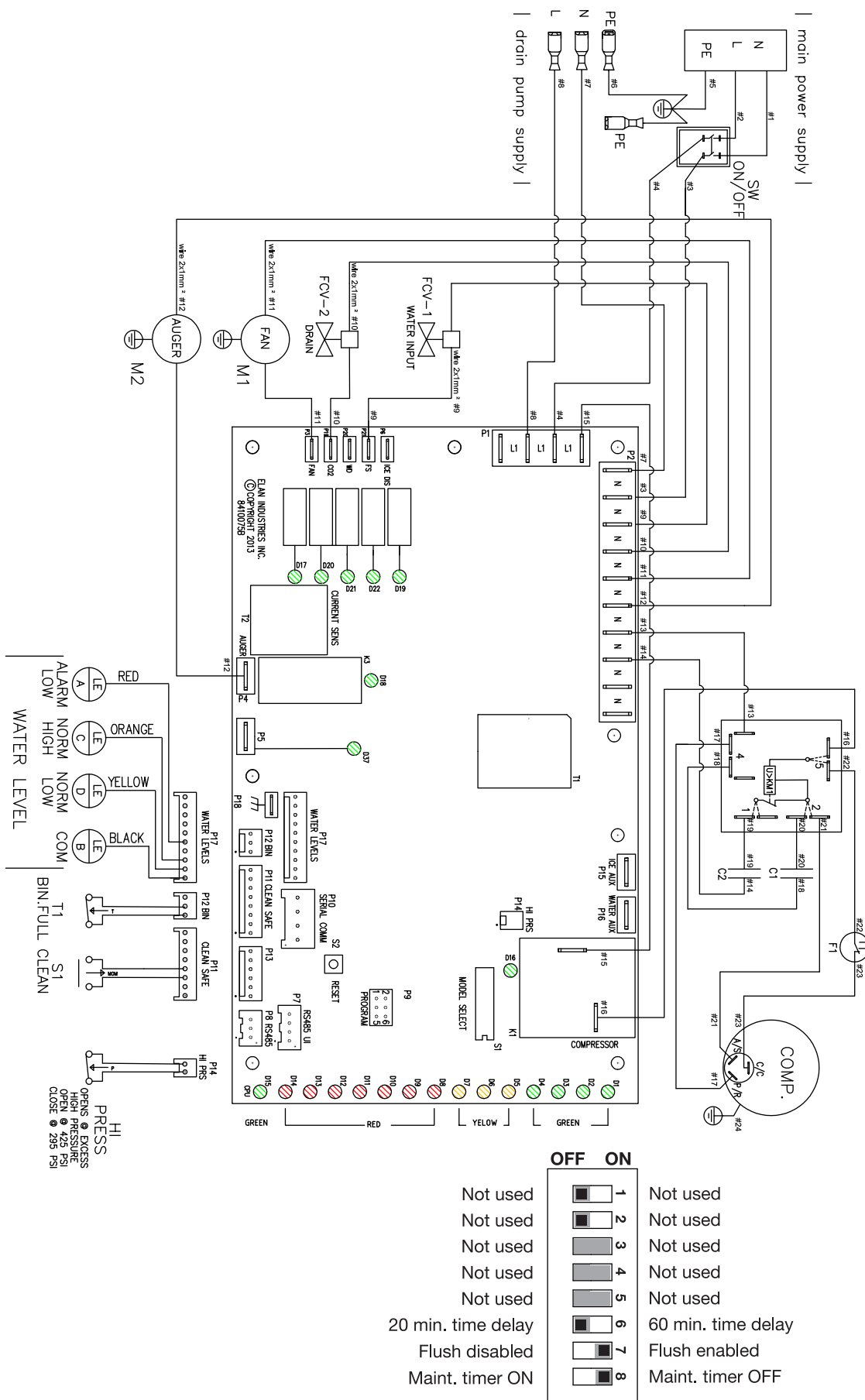

## Compressor Data

### Compressor Current Draw at 115 Vac

Ambient air temperature	60 F/15.6 C	70 F/21.1 C	80 F/26.7 C	90 F/32.2 C	100 F/37.8 C
Amperage	5.36A	5.55A	5.62A	5.8A	5.92A
High-side pressure (bar/psi)	10.8/157	15/218	16.5/239	18.8/273	20.8/302
Low-side pressure (bar/psi)	1.7/25	1.8/26	2.0/29	2.2/32	2.4/35

Locked rotor amps 48A @ 115 V

### Compressor Current Draw at 220 Vac

Ambient air temperature	60 F/15.6 C	70 F/21.1 C	80 F/26.7 C	90 F/32.2 C	100 F/37.8 C
Amperage	3.26A	3.3A	3.38A	3.45A	3.55A
High-side pressure (bar/psi)	12.2/177	14.4/209	16.8/244	18.4/267	20.8/302
Low-side pressure (bar/psi)	1.5/22	1.7/25	1.8/26	2.0/29	2.2/32

Locked rotor amps 30A @ 220 V, 60 Hz

### Compressor Current Draw at 230 Vac

Ambient air temperature	60 F/15.6 C	70 F/21.1 C	80 F/26.7 C	90 F/32.2 C	100 F/37.8 C
Amperage	3,15A	3,20A	3,25A	3,35A	3,45A
High-side pressure (bar/psi)	11,8/171	14/203	16,2/235	19/275,5	22/319
Low-side pressure (bar/psi)	2/29	2,13/31	2,27/33	2,4/35	2,55/37

Locked rotor amps 18.2A @ 230 V, 50 Hz

## Gearmotor Data

	115 V	220 V	230 V
Gearmotor current	2.25A (nominal)	0.98A (nominal)	1.3A (nominal)
Gearmotor torque-out (high amp) trip point	3.0A	1.4A	1.8A
Locked rotor amps	14A	6.8A	6.8A

	115 Vac	220 Vac	230 Vac
Resistance of windings	Yellow to black: 19 $\Omega$	Yellow to black: 45 $\Omega$	Yellow to black: 45 $\Omega$
	Black to blue: 13.2 $\Omega$	Black to blue: 29.5 $\Omega$	Black to blue: 29.5 $\Omega$
	Blue to yellow: 5.7 $\Omega$	Blue to yellow: 16.2 $\Omega$	Blue to yellow: 16.2 $\Omega$

	115 V	220 V	230 V
Compressor start winding	3.5 $\Omega$	7.5 $\Omega$	11.4 $\Omega$
Compressor run winding	0.9 $\Omega$	2.7 $\Omega$	4.9 $\Omega$

## Fan Motor Data

	115 V	220 V	230 V
Fan motor current	0.35 $\Omega$	0.2 $\Omega$	0.22 $\Omega$



## Mechanical System

### Evaporator Disassembly

1. Press **CLEAN SWITCH** to purge evaporator.
2. Disconnect power to icemaker when **LOW WATER** lights.
3. Shut off water to icemaker.
4. Disconnect plastic tubing from evaporator water inlet, drain pan stub, compression nozzle tubing and reservoir overflow tubing from secured clip.
5. Disconnect ice transport tube from compression nozzle.
6. Loosen nut and remove upper vee-band coupling from top of evaporator.
7. Lift top bearing assembly straight up with a slight rotating motion and remove.
8. Remove ice compression loop located at top of auger.
9. Lift auger straight up and out of evaporator.
10. Remove nut and lower vee-band coupling from bottom of evaporator.
11. Lift evaporator to clear bottom bearing assembly.
12. Loosen hex head bolt in side of mounting base with 5/16 wrench and lift lower bearing assembly.
13. Remove condensate shield.
14. Remove four allen head machine screws holding mounting base to gearbox.
15. If replacing evaporator, remove compression nozzle from evaporator port.

Fig. 21

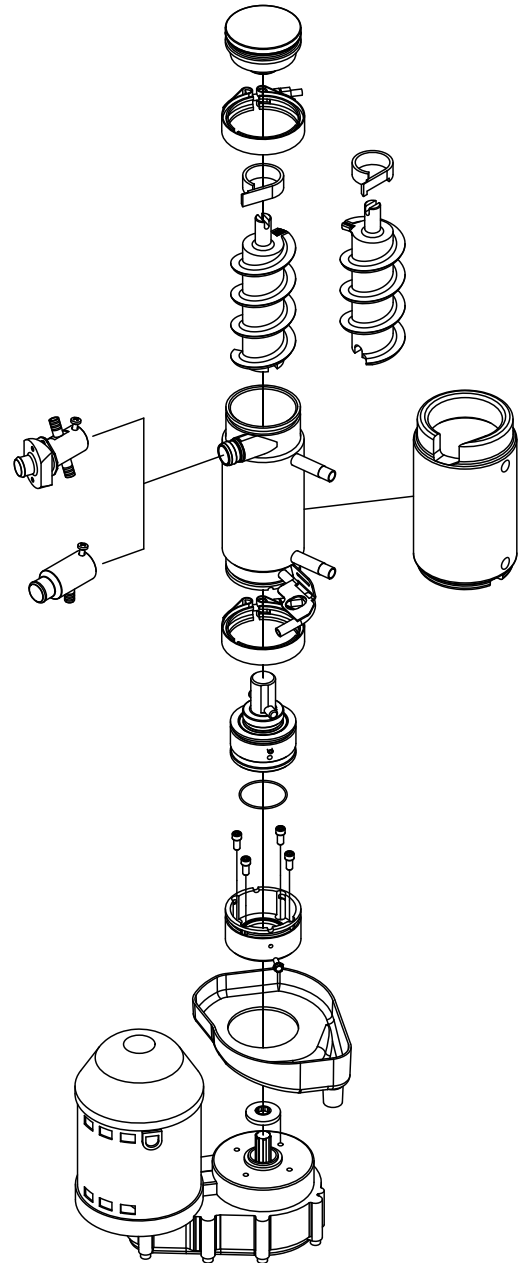

## Evaporator Reassembly

1. Clean gearmotor boss, output shaft and shaft well.
2. Install drain pan and evaporator mounting base.
3. Fill gearmotor shaft well with food-grade grease.
4. Install condensate shield and seat against gearmotor boss.
5. Install mounting base O ring in groove in evaporator mounting base.
6. Lower bottom bearing assembly into evaporator mounting base.
7. While maintaining a downward pressure on bottom bearing assembly, tighten hex head bolt with a 5/16 wrench.
8. Position evaporator over lower bearing assembly and align grooves with pins in bearing assembly.
9. Install vee-band clamp and nut and tighten to 70 in/lb.
10. Place auger in center of evaporator and rotate to mate with drive pin.
11. Install ice compression loop, orienting loop as shown.
12. Install upper bearing and seal assembly, rotating bearing to slip pin into auger slot.
13. Install upper vee-band clamp and nut and tighten to 70 in/lb.
14. If evaporator was replaced, reinstall compression nozzle.

# Refrigeration System

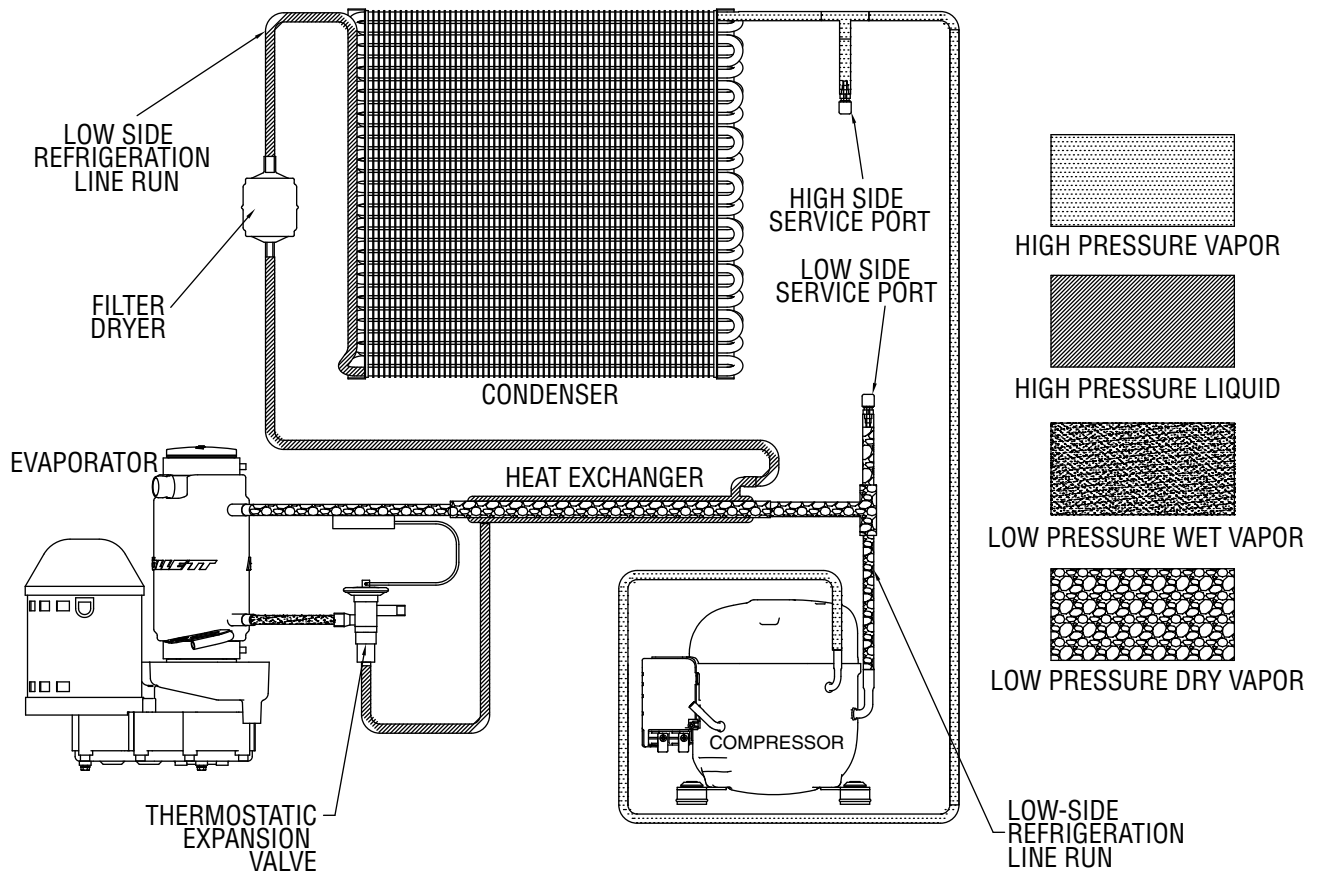

## Refrigeration Charge

All service on refrigeration systems must be performed in accordance with all federal, state and local laws. It is the responsibility of the technician to ensure that these requirements are met. Recharging icemaker to other than factory specifications will void the warranty.

### R425 icemaker charge specifications

Model	Charge	Refrigerant type
UME425A80; UMC425A80; UMD425A80; UFE425A80; UFC425A80; UFD425A80	15.34 oz (435 g)	R404A

### CAUTION!

- Recharging of unit at other than factory specifications will void icemaker warranty.

## Ice Capacity Test

Icemaker production capacity can only be determined by weighing ice produced in a specific time period.

1. Remove top panel and hopper lid of unit.
2. Weigh and record weight of container used to catch ice.
3. Run icemaker for at least 15 minutes.
4. Catch ice for 15 or 20 minutes.
5. Weigh harvested ice and record total weight.
6. Subtract weight of container from total weight.
7. Convert fractions of pounds to decimal equivalents (Ex. 6 lbs 8 oz = 6.5 lbs).
8. Calculate production using following formula:

$\frac{1440 \text{ min.} \times \text{wt. of ice produced}}{\text{Total test time in minutes}} = \text{Production capacity/24 hr. period}$
--

9. Calculated amount per 24 hours should be checked against rated capacity for same ambient and water temperatures in Ice Production Table (see page 6).

### Discharge Pressure/Suction Pressure – 115 V

		Ambient Air Temperature F/C			
		F/C	60/16	80/27	
Icemaker Inlet Water Temperature F/C	50/10	157/25	239/29	302/35	psig
		11/2	17/2	21/2	bar
	70/21	160/26	247/28	312/36	psig
		11/2	17/2	22/3	bar
	90/32	167/26	261/32	312/36	psig
		12/2	18/2	22/3	bar

### Discharge Pressure/Suction Pressure – 220 V/60 Hz

		Ambient Air Temperature F/C			
		F/C	60/16	80/27	
Icemaker Inlet Water Temperature F/C	50/10	177/22	249/25	302/32	psig
		12/2	17/2	21/2	bar
	70/21	1770/23	247/28	305/35	psig
		13/2	17/2	21/2	bar
	90/32	186/25	261/30	348/39	psig
		13/2	18/2	24/3	bar

### Discharge Pressure/Suction Pressure – 230 V/ 50 Hz

		Ambient Air Temperature F/C			
		F/C	60/16	80/27	
Icemaker Inlet Water Temperature F/C	50/10	186/21	249/25	336/36	psig
		13/1	17/2	23/3	bar
	70/21	181/23	247/29	340/38	psig
		13/2	17/2	24/3	bar
	90/32	186/25	268/33	355/41	psig
		13/2	19/2	25/3	bar

# Troubleshooting

Icemaker disposition	Possible causes	Corrective action
<p>Legend:      ● ON      ○ OFF      ◐ ON or OFF      ✖ FLASHING</p>		
<p>1. Icemaker is in running condition but not making ice.</p> <p>CLEANER FULL NOT USED HI PRESS HI AMPS SERVICE MAINT/CLEAN LOW WATER TIME DELAY SLEEP CYCLE MAKING ICE LOW BIN POWER ON</p> <p>○ ○ ○ ○ ○ ○ ○ ○ ○ ○ ● ● ✖</p>	<ol style="list-style-type: none"> <li>1. Defective compressor.</li> <li>2. Defective start relay.</li> <li>3. Defective start capacitor.</li> <li>4. Defective run capacitor.</li> <li>5. Defective main contactor.</li> <li>6. No output from PC board.</li> <li>7. Machine in Purge cycle.</li> </ol>	<ol style="list-style-type: none"> <li>1. Replace compressor.</li> <li>2. Replace start relay.</li> <li>3. Replace start capacitor.</li> <li>4. Replace run capacitor.</li> <li>5. Replace main contactor.</li> <li>6. Replace PC board.</li> <li>7. Check for Purge operation.</li> </ol>
<p>2. Machine in TIME DELAY without full bin.</p> <p>CLEANER FULL NOT USED HI PRESS HI AMPS SERVICE MAINT/CLEAN LOW WATER TIME DELAY SLEEP CYCLE MAKING ICE LOW BIN POWER ON</p> <p>○ ○ ○ ○ ○ ○ ○ ● ○ ○ ○ ○ ● ✖</p>	<ol style="list-style-type: none"> <li>1. Damaged or improperly installed thermostat (open).</li> </ol>	<ol style="list-style-type: none"> <li>1. Replace or reposition thermostat.</li> </ol>
<p>3. Icemaker is not making ice. HI AMPS.</p> <p>CLEANER FULL NOT USED HI PRESS HI AMPS SERVICE MAINT/CLEAN LOW WATER TIME DELAY SLEEP CYCLE MAKING ICE LOW BIN POWER ON</p> <p>○ ○ ○ ● ○ ○ ○ ○ ● ○ ○ ○ ● ✖</p>	<ol style="list-style-type: none"> <li>1. Poor water quality causing ice to jam auger.</li> <li>2. Ice transport tube damaged or bent.</li> <li>3. Intermittent drive output from PC board. Evaporator will freeze causing a hi amps error.</li> <li>4. Gearmotor is unplugged.</li> </ol>	<ol style="list-style-type: none"> <li>1. Clean icemaker.</li> <li>2. Inspect ice transport tube - replace if needed.</li> <li>3. Replace PC board.</li> <li>4. Plug in gearmotor.</li> </ol>
<p>4. Icemaker is not making ice. HI PRESSURE.</p> <p>CLEANER FULL NOT USED HI PRESS HI AMPS SERVICE MAINT/CLEAN LOW WATER TIME DELAY SLEEP CYCLE MAKING ICE LOW BIN POWER ON</p> <p>○ ○ ● ○ ○ ○ ○ ○ ● ○ ○ ○ ● ✖</p>	<ol style="list-style-type: none"> <li>1. High ambient temperatures &gt;100 F (38 C).</li> <li>2. Poor ventilation or air circulation.</li> <li>3. Clogged condenser or condenser filter.</li> <li>4. Fan not working properly. No air flow. <ul style="list-style-type: none"> <li>• Blocked fan blades</li> <li>• No fan output from PC board</li> <li>• Faulty fan motor</li> </ul> </li> <li>5. Icemaker is making ice. Excessive water in bin from transport tube.</li> </ol>	
<p>5. Icemaker is not making ice. Excessive water in bin from transport tube.</p> <p>CLEANER FULL NOT USED HI PRESS HI AMPS SERVICE MAINT/CLEAN LOW WATER TIME DELAY SLEEP CYCLE MAKING ICE LOW BIN POWER ON</p> <p>○ ○ ○ ○ ○ ○ ○ ○ ○ ● ● ● ✖</p>	<ol style="list-style-type: none"> <li>1. Failed water sensors. Processor assumes there is no water when there is water.</li> <li>2. Blocked reservoir vent.</li> <li>3. Defective water feed solenoid valve. Stuck in open position.</li> </ol>	<ol style="list-style-type: none"> <li>1. Clean or replace water probe assembly. Check wiring connections.</li> <li>2. Clean or replace vent tubes</li> <li>3. Replace water feed solenoid valve.</li> </ol>
<p>6. Icemaker is not making ice. LOW WATER.</p> <p>CLEANER FULL NOT USED HI PRESS HI AMPS SERVICE MAINT/CLEAN LOW WATER TIME DELAY SLEEP CYCLE MAKING ICE LOW BIN POWER ON</p> <p>○ ○ ○ ○ ○ ○ ● ○ ○ ○ ○ ○ ● ✖</p>	<ol style="list-style-type: none"> <li>1. Water supply is insufficient</li> <li>2. Low water pressure.</li> <li>3. Defective water feed solenoid valve. Stuck in closed position.</li> <li>4. No water feed output from PC board.</li> </ol>	<ol style="list-style-type: none"> <li>1. Restore water supply and check water filters. If evaporator was completely empty the reset button may have to be pressed to restart the icemaker.</li> <li>2. Icemaker will eventually start when water reaches normal LO level.</li> <li>3. Replace water feed solenoid valve.</li> <li>4. Replace PC board.</li> </ol>

# Replacement Parts

## Evaporator Assembly

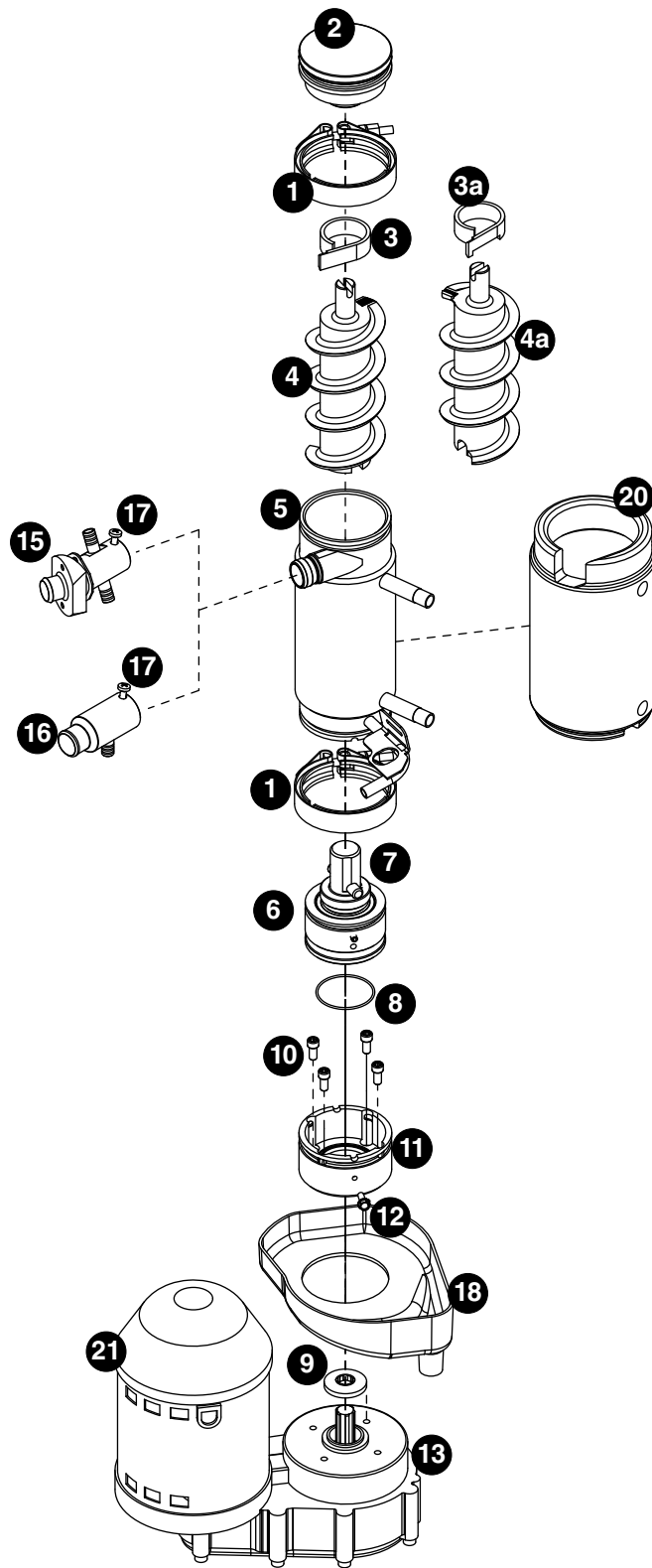

Reference #	Description	Part #
1	Coupling, vee-band, includes nut	502735
2	Bearing assembly, top	502736
3	Loop, ice compression, beveled	502110
3a	Loop, ice compression, notched (Flaker component)	00124115
4	Auger	502737
4a	Auger, with paddle (Flaker component)	00124123
5	Evaporator assembly (does not include insulation jacket)	01096205
6	O-ring, bearing housing	500496
7	Bearing assembly, bottom	502738
8	O-ring, mounting base	501063
9	Shield, condensate	500744
10	Screw, Allen 1/4 20 x 1/2 (set of 4)	501080
11	Mounting base, evaporator (includes 501063)	502733
12	Bolt, mounting base	502227
13	Gearbox & motor 115 V	502730
13	Gearbox & motor 220 V 60 Hz/230 V 50 Hz	502832
Not shown	Mounting base, gearbox	01067693
15	Compression nozzle, Micro Chewblet, assembly	01092584
16	Compression nozzle, Flaker, assembly	01092592
17	Screw, compression nozzle mounting	00911743
18	Drain pan, evaporator	00181990
Not shown	Grease	501111
19	Bracket, drain hose	01007087
20	Insulation jacket, evaporator	00946392
Not shown	Relay, gearmotor	00142042
21	Cover, plastic	01012228
Not shown	Insulation, compression nozzle	01092568

# Components Assembly

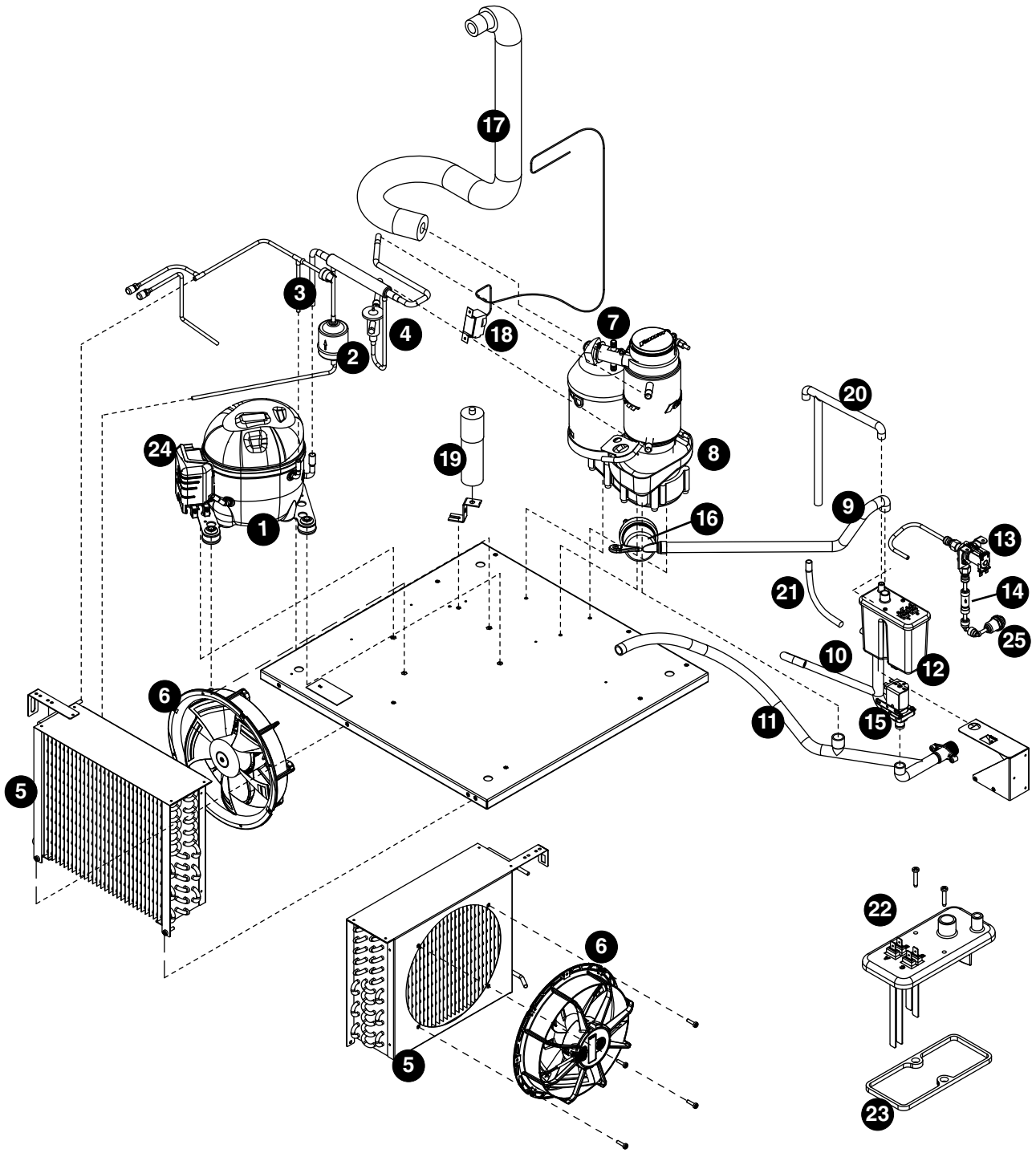



Reference #	Description	Part #
1	Compressor, 230 V 50 Hz	01079599
1	Compressor, 220 V 60 Hz	01079607
1	Compressor, 115 V 60 Hz	01079581
2	Filter, dryer	00177527
3	Switch, high pressure	00117077
4	Valve, expansion	01079615
5	Condenser	01079433
6	Fan, condenser 230 V 50/60 Hz	01079441
6	Fan, condenser 115 V 50/60 Hz	01076504
7	Compression Nozzle, Flaker, assembly	01092592
7	Compression Nozzle, Micro Chewblet, assembly	01092584
8	Pan, drain	00181990
9	Tube, sanitizer	01092865
10	Tube, water feed	01056225
11	Tube, drain line	01056241
12	Water reservoir assembly	01093517
13	Valve, water feed solenoid 220 V 60 Hz/230 V 50 Hz	00130831
13	Valve, water feed solenoid 115 V (includes bracket)	01401116
14	Valve, check	01066166
15	Valve, purge 220 V 60 Hz/230 V 50 Hz	00991190
15	Valve, purge 115 V	00991216
16	Cup, cleaning	01065226
17	Tube, ice transport (includes insulation and clamp)	01079623
18	Bin thermostat	500514
19	Capacitor, compressor run 115 V 60 Hz	01082494
19	Capacitor, compressor run 220 V 60 Hz	01082528
19	Capacitor, compressor run 230 V 50 Hz	01082551
20	Tube, nozzle vent	01092857
21	Tube, nozzle to reservoir	01098862
22	Lid, water reservoir (includes screws, probes, elbow and gasket)	01099118
23	Gasket, water reservoir	00990978
24	Overload switch, compressor (230 V 50 Hz)	01099191
24	Overload switch, compressor (115 V 60 Hz)	01099209
24	Overload switch, compressor (220 V 60 Hz)	01099217
25	Water inlet, push in	00976787

## External Components

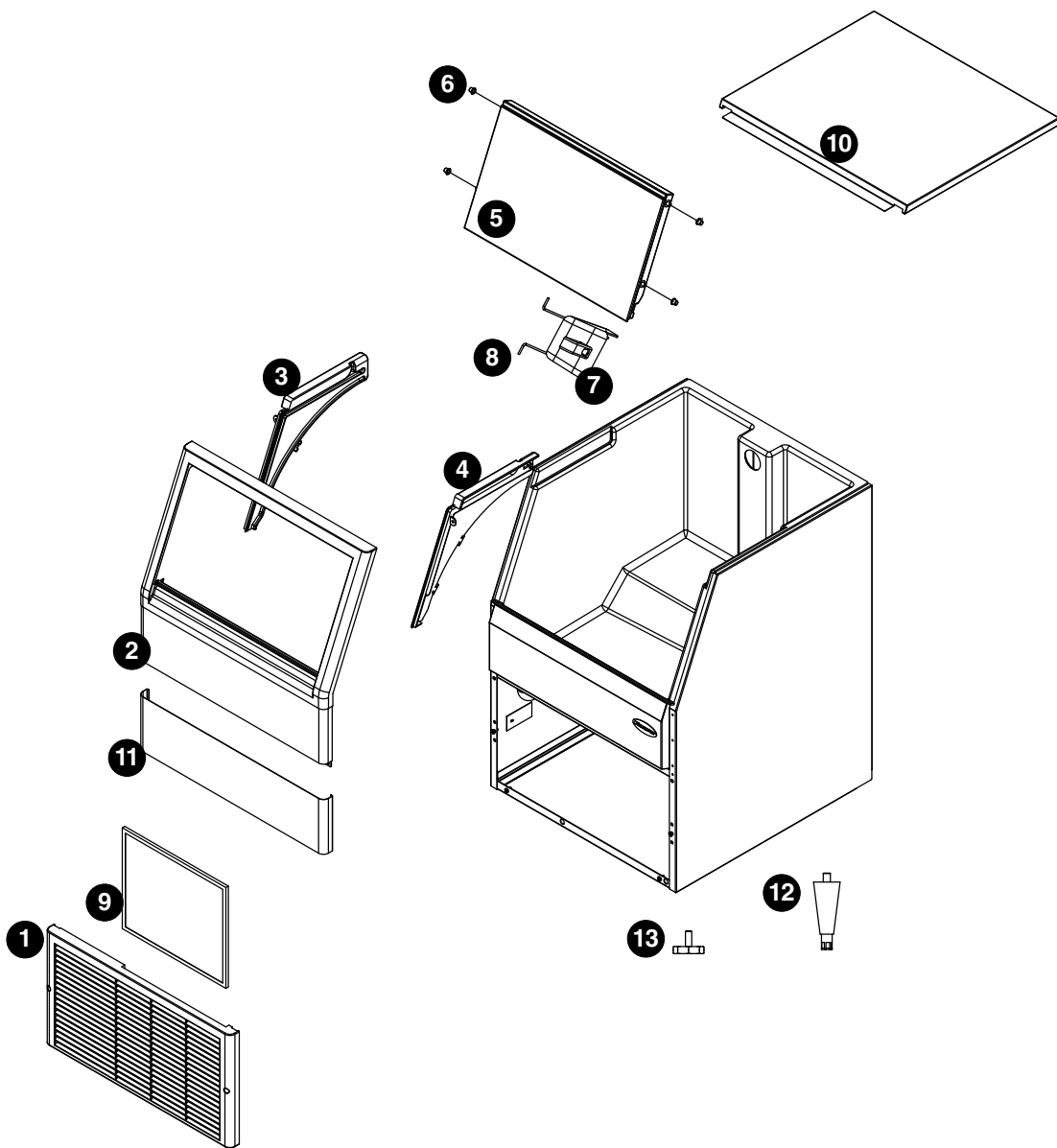

Reference #	Description	Part #
1	Grille, front cover	01079474
2	Frame, door assembly	01079482
3	Guide, door slide left	01079490
4	Guide, door slide right	01079508
5	Sliding doors	01079540
6	Roller, doors	01056407
7	Scoop	01056415
8	Holder, scoop	01056423
9	Filter, condenser	01058544
10	Cover, top	01032556
11	Cover, front stainless steel blend	01079532
12	Legs, 6" (150 mm) accessory (set of 4)	205440
13	Feet, leveling (each)	01066224

# Electrical Box

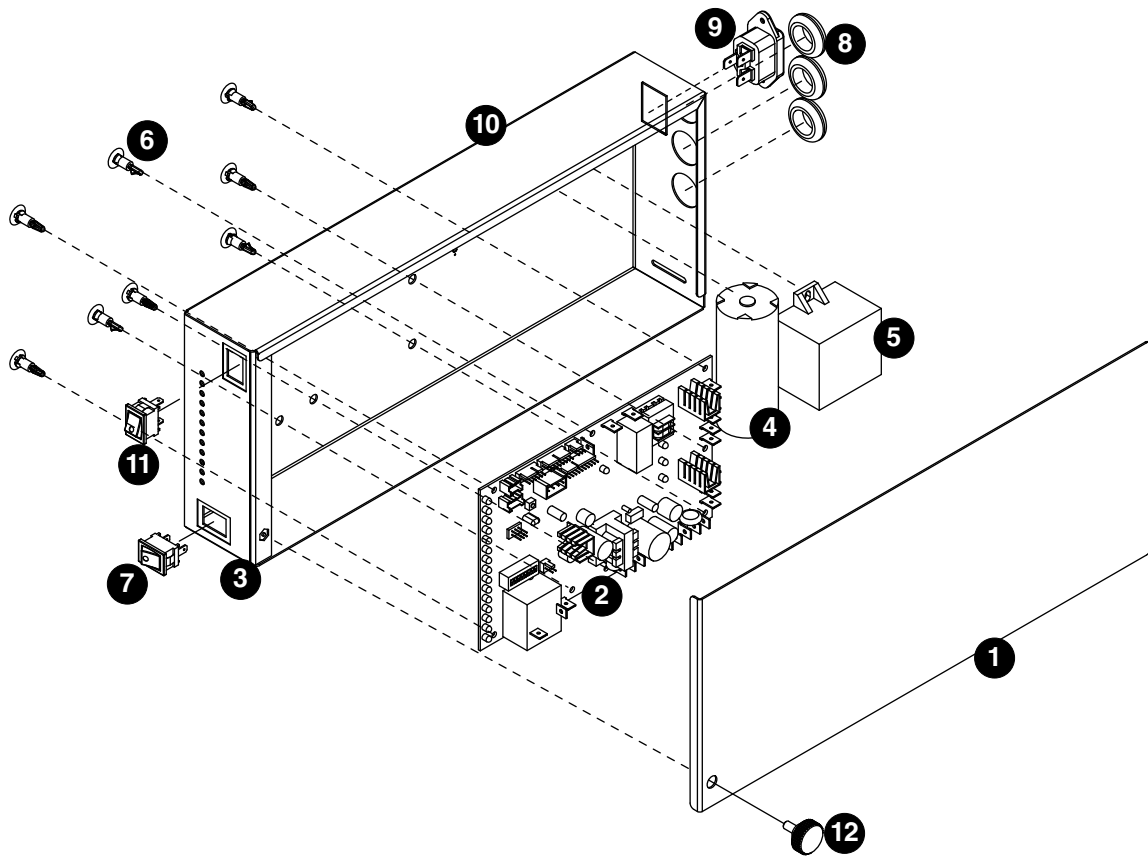

Reference #	Description	Part #
1	Cover, includes thumbscrew	01079573
2	Main board 115 V (includes stand-offs)	01064708
2	Main board 220 V 60 Hz (includes stand-offs)	01092543
2	Main board 230 V 50 Hz (includes stand-offs)	01092550
3	Label, LED	01016914
4	Capacitor, compressor start 230 V 50 Hz	01082569
4	Capacitor, compressor start 220 V 60 Hz	01082536
4	Capacitor, compressor start 115 V 60 Hz	01082502
5	Relay, compressor start 230 V 50 Hz	01082577
5	Relay, compressor start 220 V 60 Hz	01082544
5	Relay, compressor start 115 V 60 Hz	01082510
6	Stand-offs 115 V	00903005
	Stand-offs 220 V 60 Hz/230 V 50 Hz	01066208
7	Switch, clean	01066539
8	Grommet	00177907
9	Inlet, power supply IEC	01115930
10	Frame, electric box	01061092
11	Switch, on/off	01086024
12	Thumbscrew, knurled	01082791
Not Shown	Cord and plug 115 V	01078039
Not Shown	Cord, 220 V 60 Hz/230 V 50 Hz	01066547

## Bin Drain

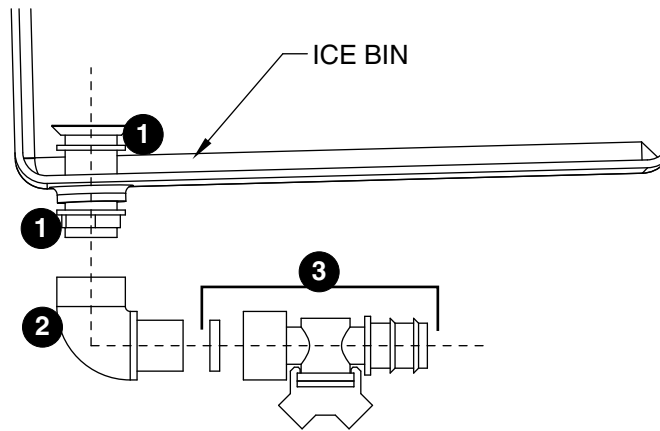

Reference #	Description	Part #
1	Bin drain fitting	01066042
2	Elbow 3/4"	01066018
3	Bin drain valve (includes gasket)	01066026

## Water Connections 220 V 60 Hz/230 V 50 Hz

Reference #	Description	Part #
Not shown	3/8" push-in x 1/2" BSP	01083211
Not shown	3/8" tubing x 3 m	208592

## Drain Line Components 220 V 60 Hz/230 V 50 Hz

Reference #	Description	Part #
Not shown	3/4" drain elbow	01092519
Not shown	3/4" barbed thread	01092501
Not shown	3/4" tubing (25,3 mm x 3 m)	00949917
Not shown	Clamp	01083278

## Micro Chewblet Nozzle

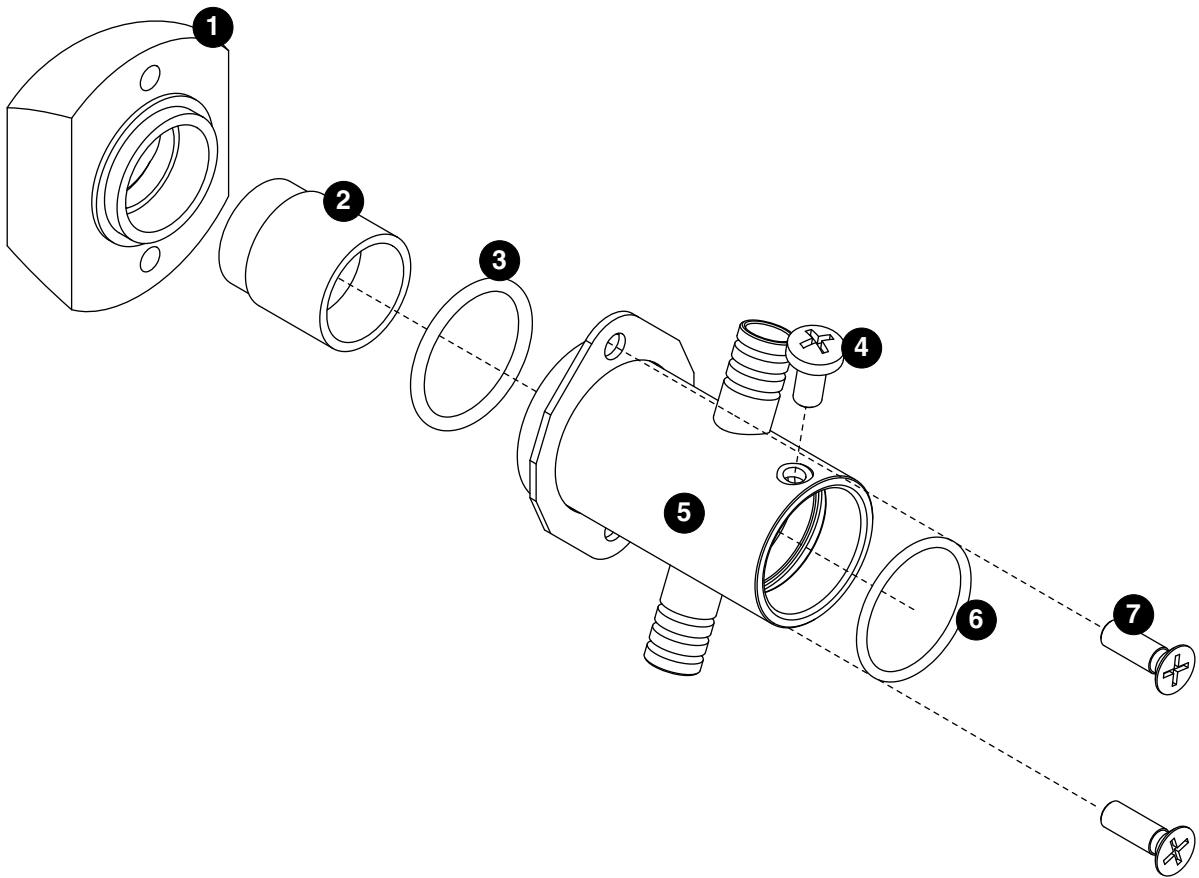

Reference #	Description	Part #
1	Ice breaker	01066794
2	Nozzle, compression	01066802
3	O-ring, 22 x 3	01081074
4	Screw, M5 x 10	00911743
5	Holder with clamp, nozzle	01073303
6	O-ring, 22 x 2	01081066
7	Screw, M5 x 16	00911750
Not shown	Insulation, compression nozzle	01092568

## Flaker Nozzle

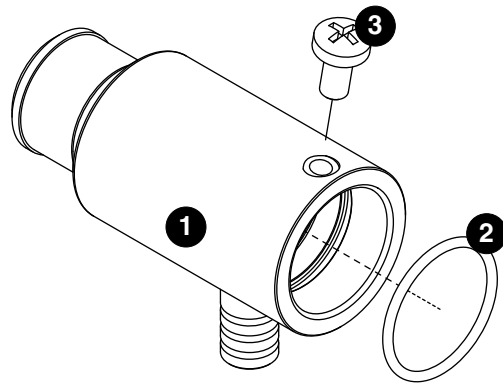

Reference #	Description	Part #
1	Nozzle, flaker	01076876
2	O-ring, 22 x 2	01081066
3	Screw, M5 x 10	00911743
Not shown	Insulation, compression nozzle	01092568

## Icemaker Cleaner/Descaler

00132001	SafeCLEAN environmentally-friendly cleaner, carton of 24 x 7 oz packets
----------	---

## Icemaker Sanitizer

00979674	Nu-Calgon IMS-II Sanitizer, 16 oz. bottle
00131524	Sponge, sanitary, each

## Water Treatment Accessories

Reference #	Description	Part #
<b>Standard capacity filter system</b>		
Not shown	Follett QC4-FL4S water filter system (includes FL4S primary cartridge and head, coarse pre-filter and head, pressure gauge, flushing valve; assembled and installed on mounting bracket), one per ice machine	00130229
Not shown	Follett FL4S primary replacement cartridge	00130245
Not shown	Water filter cartridge – primary, carton of 6	00954297
Not shown	Everpure coarse pre-filter cartridge	00130211
Not shown	Water pre-filter cartridge – pre-filter, carton of 12	00954305
<b>Carbonless high capacity filter system</b>		
Not shown	Carbonless high capacity water filter system (one per ice machine) – Horizon™ and MaestroPlus series ice machines	01050442
Not shown	Carbonless high capacity water filter cartridge – primary, single	01050426
Not shown	Carbonless high capacity water filter cartridge – primary, carton of 6	01050434
Not shown	Water pre-filter cartridge – pre-filter, single	00130211
Not shown	Water pre-filter cartridge – pre-filter, carton of 12	00954305



Micro Chewblet and SafeCLEAN Plus are trademarks of Follett Products LLC.  
Chewblet and Follett are registered trademarks of Follett Products LLC, registered in US.



801 Church Lane • Easton, PA 18040, USA  
Toll free (877) 612-5086 • +1 (610) 252-7301  
[www.follettice.com](http://www.follettice.com)

Follett Europe Polska Sp. z o.o.  
Mokry Dwór 26 c • 83-021 Wiślina, Poland  
+48 (58) 785-6140 • Fax +48 (58) 785-6159  
[www.folletteurope.com](http://www.folletteurope.com)

01083237R03  
© Follett Products LLC 2/21