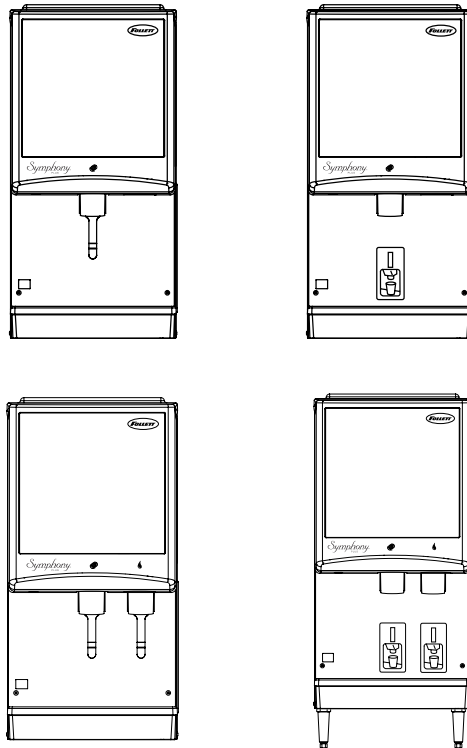




# Symphony Plus™ 12 Series Ice and Water Dispensers R290, 230 V 50 Hz

## Operation and Service Manual



### Welcome to Follett

Follett equipment enjoys a well-deserved reputation for excellent performance, long-term reliability and outstanding after-the-sale support. To ensure that this equipment delivers that same degree of service, review this guide carefully before you begin your installation.

Should you have need technical help, please call our Technical Service group at (877) 612-5086 or (610) 252-7301.

Please have your model number, serial number and complete and detailed explanation of the problem when contacting Technical Service.

### Getting Started

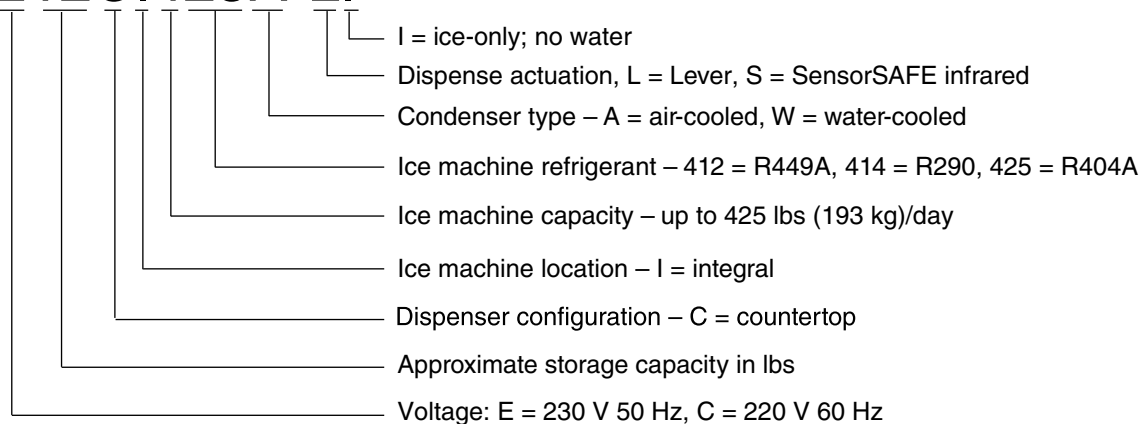
After uncrating and removing all packing material. Inspect the equipment for concealed shipping damage. All freight is to be inspected upon delivery. If visible signs of damage exist, please refuse delivery or sign your delivery receipt "damaged." Follett Customer Service must be notified within 48 hours. Wherever possible, please include detailed photos of the damage with the original packaging so that we may start the freight claim process.

# Contents

<b>Welcome to Follett.</b> .....	<b>3</b>
Before you begin. ....	3
<b>Specifications</b> .....	<b>4</b>
<b>Installation</b> .....	<b>5</b>
<b>User information</b> .....	<b>7</b>
<b>Cleaning</b> .....	<b>8</b>
Weekly .....	8
Monthly .....	8
Semi-Annually (more often if conditions dictate) .....	8
<b>Service</b> .....	<b>10</b>
Ice machine operation (all models) .....	10
The icemaking process. ....	10
Water system .....	11
Electrical system. ....	14
Wiring diagram - 230 V 50 Hz .....	16
Wiring diagram - Lever only .....	20
Wiring diagram - SensorSAFE only .....	21
Ice machine operational and diagnostic sequences .....	22
Diagnostic stages .....	28
Refrigeration pressure data .....	32
Compressor data .....	32
Gearmotor data .....	32
Refrigeration system. ....	32
<b>Dispenser troubleshooting</b> .....	<b>34</b>
<b>Disassembly and replacement instructions.</b> .....	<b>36</b>
Fan removal .....	39
Thermostat and ice transport tube replacement .....	40
<b>Replacement parts</b> .....	<b>41</b>
<b>Water treatment accessories for Symphony Plus ice and water dispensers.</b> .....	<b>53</b>

Check your paperwork to determine which model you have. Follett model numbers are designed to provide information about the type and capacity of Follett ice dispensing equipment.

## E12CI425A-LI





**WARNING! Risk of fire or explosion. Flammable refrigerant used. Follow handling instruction carefully. To be repaired only by trained service Personnel.**



**WARNING! Do not puncture Refrigerant Tubing. Do not use this product with flammable gases or flammable solvents.**



**WARNING! Do not store flammable gases, flammable liquids or flammable solids in these units. Do not use FLAME to check for gas leak.**



**WARNING! Do not under any circumstances try to modify or repair valves, regulator, connectors, controls or any other appliance. Doing so creates the risk of a gas leak.**



**WARNING! Keep ventilaton openings clear of obstruction.**



**WARNING! Do not damage the refrigerant circuit.**



**WARNING! Connect to potable water supply only.**



**WARNING: When positioning the appliance, ensure the supply cord is not trapped or damaged.**



**WARNING: Do not locate multiple portable socket-outlets or portable power supplies at the rear of the appliance.**



**WARNING: All dispensers must be installed level in both directions to ensure proper operation.**

**ATTENTION: The A-weighted sound pressure level is below 70 dB.**



## **CAUTION!**

Read this manual thoroughly before operating, installing or performing maintenance on the equipment. Failure to follow instructions in this manual can cause property damage, injury or death.

The ice machine contains R290 (propane) refrigerant. R290 (propane) is flammable in concentrations of air between approximately 2.1% and 9.5% by volume. R290 (propane) may burn if exposed to a heat source above 470 °C.

When servicing this equipment, be sure to lock the circuit breaker, and display an in-service notice.

This appliance intended to be connected to the water mains by a hose-set. New hose-sets supplied with the appliance should be used, old hose-sets should be discarded.

All Federal, State, and Local regulations must be followed when connecting this appliance to water mains.

This appliance is only to be installed in locations where it can be overseen by trained personnel.

This equipment contains high-voltage electricity and refrigerant charge. Installation and repairs are to be performed by properly trained technicians aware of the dangers of dealing with high voltage electricity and refrigerant under pressure. The technician must also be certified in proper refrigerant handling and servicing procedures. All lockout and tag out procedures must be followed when working on this equipment.

Repair on R290 systems must always be done in a well-ventilated area.

Because R290 is highly flammable, a combustible gas leak detector is required when servicing R290 systems.

Only use parts recommended or provided by the manufacturer.

Routine adjustments and maintenance procedures outlined in this manual are not covered by the warranty.

We reserve the right to make product improvements at any time. Specifications and design are subject to change without notice.

Do not tilt unit further than 30° off vertical during uncrating or installation.

Dispenser bin area contains mechanical, moving parts. Keep hands and arms clear of this area at all times. If access to this area is required, power to unit must be disconnected first.

This appliance is not suitable for installation in an area where a water jet could be used.

This appliance must not be cleaned by a water jet.

User maintenance should not be done by children.

Follett recommends a Follett water filter system be installed in the ice machine inlet water line (standard capacity #00130229, high capacity #00978957, carbonless high capacity #01050442).

Prior to operation clean the dispenser in accordance with instructions found in this manual.

Do not block air intake or exhaust.

This appliance should be permanently connected by a qualified person in accordance with application codes.

A qualified person shall provide a readily accessible disconnect device incorporated into the fixed wiring.

If the supply cord is damaged, it must be replaced by the manufacturer, its service agent or similarly qualified persons in order to avoid a hazard.

This appliance can be used by children aged 8 years and above and persons with reduced physical, sensory, or mental capabilities, or lack of experience and knowledge if they have been given supervision or instruction concerning use of the appliance in a safe way and understand the hazards involved. Children should be supervised to ensure that they do not play with the appliance.

This appliance is designed for commercial use.

To avoid a hazard due to instability of the appliance, it must be fixed in accordance with the instructions.

Warranty does not cover exterior or outside installations.

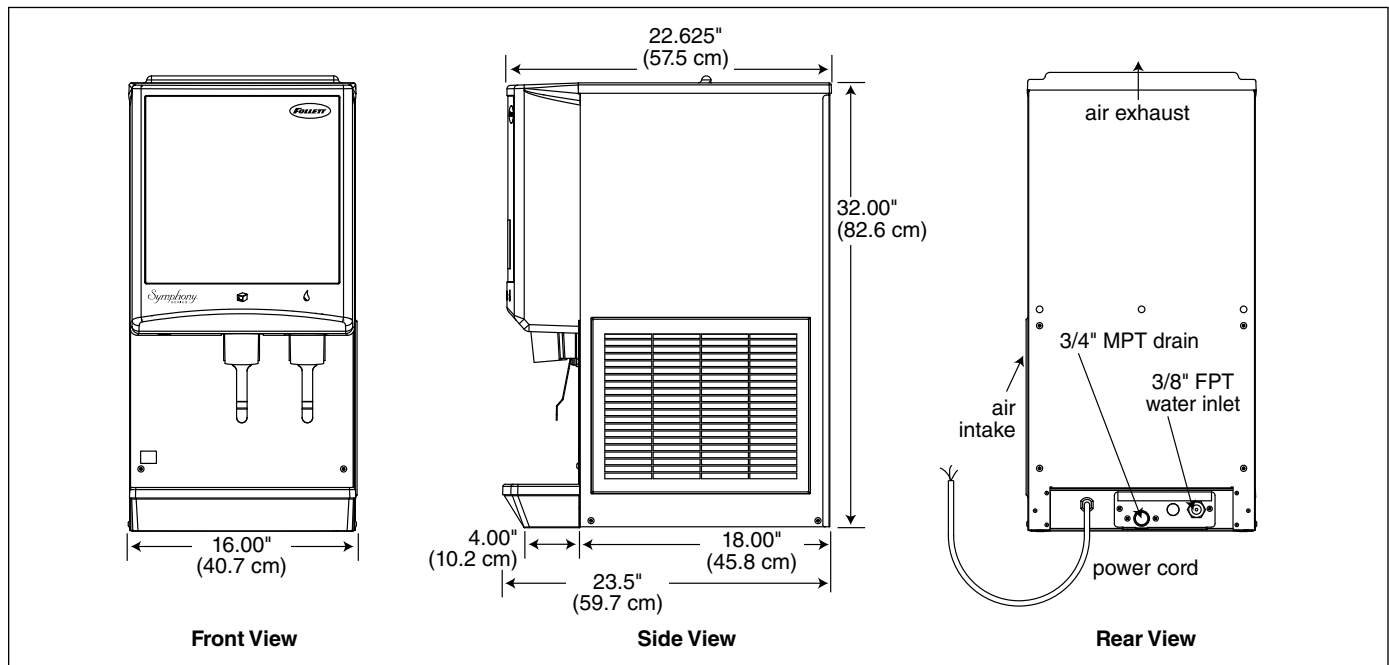
To reduce risk of shock, disconnect power before servicing.

Connect to potable water supply only.

Ice is slippery. Maintain counters and floors around dispenser in a clean and ice-free condition.

Ice is food. Follow recommended cleaning instructions to maintain cleanliness of delivered ice.

## Specifications



### Electrical

- 230 V, 50 Hz, 1 phase, 5.5A
- Connect to a dedicated circuit.

### Ambient

Air temp*	100 F/38 C Max.	50 F/10 C Min. Best performance below 80 F (27 C)
Water temp†	90 F/32 C Max.	45 F/4 C Min. Best performance below 70 F (21 C)
Water pressure	70 psi/482 kPa max.	10 psi/69 kPa min.

\* Ambient air temperature is measured at the air-cooled condenser coil inlet.

† Ambient water temperature is measured in the ice machine reservoir.

### Plumbing

	<b>E12CI414A</b>
Dispenser drain	3/4" MPT
Water inlet	3/8" FPT

**Note:** Water shut-off recommended within 10 ft. (3 m) of dispenser. Drain to be hard-piped and insulated. Maintain at least 1/4" per foot (20 mm per 1 m) run of slope.

### Ventilation clearances

- 6" (15.3 cm) on right side of dispenser, 24" (61 cm) at top for ventilation and 12" (30.5 cm) at top recommended for service.

**Note:** Do not block right side air intake or top air exhaust.

### Dry weight

- 144 lb (65 kg)

# Installation

## Before you begin

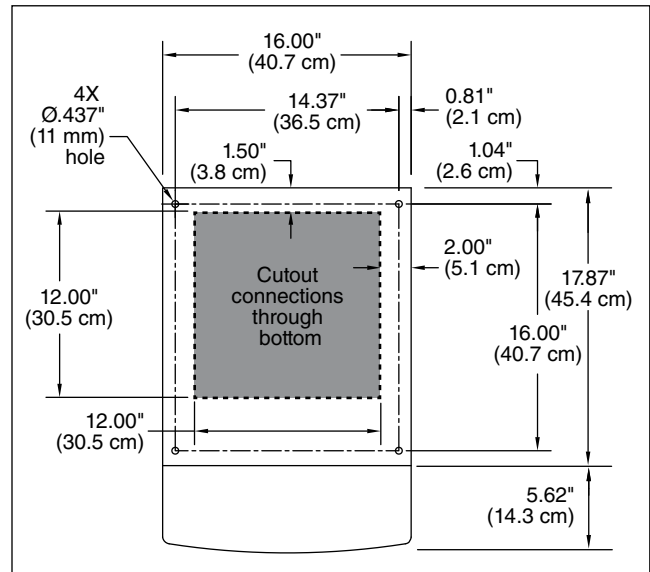
- All dispensers must be installed level in both directions to ensure proper operation.
- Service and ventilation clearances: 6" (15.3 cm) on right side of dispenser, 6" (15.3 cm) at top for ventilation and 12" (30.5 cm) at top recommended for service.
- Countertop units installed without legs provide the option of taking utilities out bottom or back of dispenser (on wall mount units and countertop units with legs, utilities exit from back). See counter cutout drawings for bottom exiting utilities. For installations where utilities exit through back of dispenser, refer to back view drawings.
- Counter depth must allow front of sink to be a minimum of 30.00" (76.2 cm) from wall.

## Installing countertop dispensers without legs

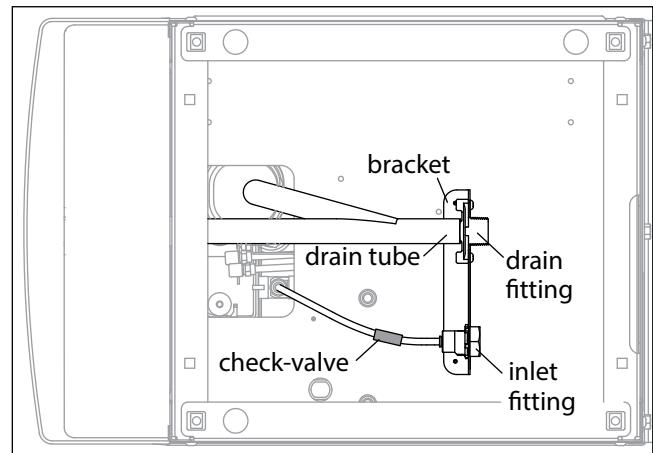
## Installing countertop dispensers without legs

1. Position dispenser in desired location, mark dispenser outline on counter and remove dispenser.
2. Regardless of whether utilities will exit through back or bottom of dispenser, drill four 7/16" holes in counter to anchor dispenser to counter (**Fig. 1**).
3. **For utilities exiting through bottom only:**
  - (a) Make cut out (**Fig. 1**).
  - (b) Move drain fitting from back of dispenser and mount (**Fig. 2**).
  - (c) Cut drain tube to length and attach to barbed connection.
  - (d) Move inlet water fitting from back of dispenser and mount (**Fig. 2**).
  - (e) Cut water tubing to length and re-insert into water fitting.
4. **For all units:** Apply a thick bead approximately 1/4" (7 mm) diameter of NSF-listed silicone sealant (Dow Corning RTV-732® or equivalent) 1/4" (7 mm) inside marked outline of dispenser.
5. Carefully lower dispenser on counter in proper position and secure to counter with four (4) 3/8"-16UNC bolts.
6. Smooth excess sealant around outside of dispenser.

**Fig. 1**



**Fig. 2 - Bottom exiting utilities (countertop units)**



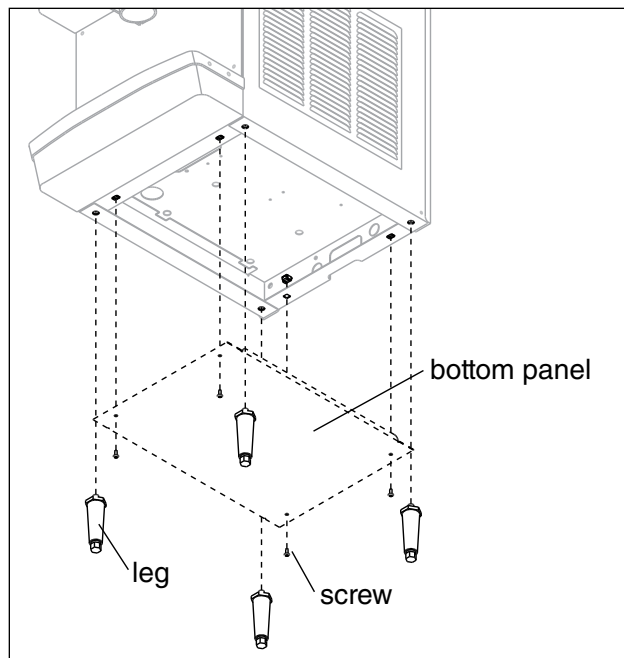
## Installing countertop dispensers with legs accessory (P/N AF10LBLEGS)

### CAUTION!

- Do not tilt unit further than 30° off vertical plane.
- Countertop dispensers that sit on legs (not bolted to counter) can be inadvertently moved. Care should be taken when operating and cleaning to avoid accidents.

1. Carefully tip dispenser back to expose underside and block up in place.
2. Screw legs (shipped taped to drain pan of dispenser) into dispenser bottom, taking care to seat legs securely against underside of dispenser.
3. Attach bottom panel and hardware to bottom of dispenser with supplied screws (**Fig. 3**).
4. Position unit in desired location and adjust legs to level in both directions.
5. Make final connections.

**Fig. 3 - Bottom panel and leg assembly**



## User information

### How the dispenser works

Follett's 12 series automatic-load ice and water dispensers are equipped with Follett's 425 lb (193 kg)/day ice machine. In the continuous icemaking process, water freezes to the inside wall of the evaporator. A rotating stainless steel auger carries the ice to the top of the evaporator where it is compressed and extruded through an outlet port. The ice is then pushed through a tube to the storage hopper. When the hopper is full, a bin thermostat opens and shuts the ice machine off. When the dispense mechanism is activated, a dispense motor is turned on, causing the wheel to turn. This moves ice to the dispense chute where it drops by gravity into the container held below the chute.

### How SensorSAFE infrared dispensing works

Follett's SensorSAFE infrared dispensing maximizes sanitation and minimizes the possibility of cross-contamination by eliminating physical contact between the cup or container and dispenser. Sensors in the panel use reflected infrared light to detect the presence of the container and send a signal to a control board which then activates the appropriate components for ice or water dispensing.

The SensorSAFE infrared dispensing package includes a cleaning switch under the left side of the front cover which temporarily shuts off dispensing to allow cleaning of the panel and lenses. If the switch is not turned back on after cleaning, the dispenser automatically resets after two minutes for normal operation.

SensorSAFE infrared dispensing also includes a time limit safety feature which automatically stops ice dispensing after one minute of continuous dispensing. Dispensing can be resumed by moving the container away from the dispenser and returning it to the activation zone.

## Cleaning

Follett ice machines and dispensers, and their associated cleaning and sanitizing procedures, are designed for use with potable water sources. The presence, or suspected presence, of infectious agents may call for additional measures, including the replacement of components and more comprehensive disinfection measures. Follett recommends that these cleaning and sanitizing procedures be reviewed with the appropriate infectious agent subject matter experts to assure complete remediation.

Periodic cleaning of Follett's ice and water dispenser and ice machine system is required to ensure peak performance and delivery of clean, sanitary ice. The recommended cleaning procedures that follow should be performed at least as frequently as recommended and more often if environmental conditions dictate.

Follett recommends sanitizing the pressurized water lines prior to cleaning the ice machine/dispenser. Follett offers two kits: order P/N 01089572 when a Follett filter system with a pre-filter bowl is present, or P/N 01089580 when a Follett filter system is not present. Follow the instructions provided with the respective kits to sanitize the pressurized water lines immediately before cleaning the ice machine/dispenser.

Cleaning of the condenser can usually be performed by facility personnel. Cleaning of the ice machine system should be performed by your facility's trained maintenance staff or a Follett authorized service agent. Regardless of who performs the cleaning, it is the operator's responsibility to see that this cleaning is performed according to the schedule below. Service problems resulting from lack of preventive maintenance will not be covered under the Follett warranty.

### Recommended cleaning intervals\*

Symphony Plus	Frequency
Drain Line	weekly
Drain Pan/Drip Pan	weekly
Exterior	as needed
Condenser	monthly (air-cooled only)
Dispenser and Components	semi-annually
Ice Machine	semi-annually
Transport Tube	semi-annually
Ice Storage Area/Bin	semi-annually

\* Ice machine and dispenser must be cleaned prior to start-up.

### Weekly

#### CAUTION!

- Do not use solvents, abrasive cleaners, metal scrapers or sharp objects to clean any part of the dispenser.

#### Dispenser drain pan and drain line

- Pour 1 gal. (3.8 L) of hot tap water into drain pan to flush drains.

#### Splash panel front, SensorSAFE™ infrared dispensing

- Deactivate dispensing by pressing and releasing clean switch located on left side of unit under top front cover.
- Clean lens and splash panel front using a soft cloth and mild, non-abrasive, non-chlorine based cleaner.
- Reactivate dispensing by pressing and releasing clean switch again.

### Monthly

#### CAUTION!

- Do not use solvents, abrasive cleaners, metal scrapers or sharp objects to clean any part of the dispenser.

#### Condenser (air-cooled ice machine only)

- Use a vacuum cleaner or stiff brush to carefully clean condenser coils of lint and debris to ensure optimal performance.



## Semi-Annually (more often if conditions dictate)

- A cleaning procedure should always include both the ice machine and dispenser.
- Icemaking system can be cleaned in place.



### CAUTION!

- Wear rubber gloves and safety goggles (or face shield) when handling SafeCLEAN Plus.
- Use only Follett approved cleaners.
- Do not use solvents, abrasive cleaners, metal scrapers or sharp objects to clean any part of the dispenser.

### Cleaning tool checklist

- (1 or 2) 1.5 gallon (or larger) plastic bucket
- (2) clean cloths
- Sanitary gloves
- Safety glasses
- (2) SaniSponge™ (P/N 00131524 - single sponge)
- SafeCLEAN Plus ice machine cleaner

**SafeCLEAN Plus Solution:** Follow the directions on the SafeCLEAN Plus packaging to mix 1 gal. (3.8 L) of Follett SafeCLEAN Plus solution. Use 100 F (38 C) water.

## Ice Machine and Dispenser

### Cleaning procedure

**Note:** Check drains and drain cup to ensure they are open and flowing freely.

1. If ice machine was running recently, ensure that the evaporator is completely free of ice before proceeding. If there is ice in the evaporator, complete steps 2-7 using only hot water to remove the ice then begin Cleaning Procedure again.
  2. Remove front cover and turn OFF bin signal switch.
  3. Dispense all ice from storage hopper and discard.
  4. Remove top of machine and hopper lid.
  5. Press **CLEAN** switch. The **MAINTENANCE** light will turn on and the machine will drain. Wait for the **LOW WATER** light to turn on.
  6. Remove lid from cleaning cup and fill (about 1 quart) until SafeCLEAN Plus solution overflows from the ice transport tube into the hopper. Place lid back on cup. Save remainder of SafeCLEAN Plus solution.
  7. **CLEANER FULL** light will turn on and machine will start cleaning cycle then rinse three times; this process takes approximately 15 minutes.
  8. While ice machine is cleaning, clean dispenser as follows:
    - a. Remove center thumbscrew, locking plate, two wingnuts and backing plate from front of storage hopper.
    - b. Remove stud assembly, baffle, wheel, and any remaining ice.
    - c. Remove dispense chutes from splash panel.
    - d. Submerge drain grille in SafeCLEAN Plus solution and allow to soak to remove any scale buildup.
    - e. Wipe inside of hopper lid, stud assembly, baffle, wheel, inside of storage area, dispense chutes, drain grille and drain pan with damp cloth wrung out in SafeCLEAN Plus solution. Thoroughly rinse all parts with damp cloth wrung out with clean water.
- Note:** To avoid possible damage to motor assembly, only use a damp cloth to clean storage hopper. Do not allow water to run through motor shaft hole in bottom of hopper.
9. When machine is finished cleaning, the **MAINTENANCE** light will turn off.

10. Reinstall dispense chutes, wheel, baffle, stud assembly and knurled nuts.
11. Remove top bearing insulation. Loosen Phillips-head screw on nozzle connected to evaporator. Remove nozzle from evaporator side only, leave other side of nozzle connected to transport tube.
12. Soak one SaniSponge in remaining SafeCLEAN Plus solution.
13. Insert the sponge soaked in SafeCLEAN Plus solution into nozzle then insert a dry sponge into the nozzle.
14. Replace nozzle onto evaporator and tighten screw. Ensure drain is connected to reservoir and vent tubes are connected to evaporator drain pan. Replace top bearing insulation.
15. Turn ON bin signal switch. Wait for ice to push sponges through transport tube.
16. Collect sponges from ice storage bin.
17. Replace hopper lid, machine top, and install front cover.
18. After 10 minutes, dispense all ice and discard.

### **User Interface and Exterior Cabinet**

- Clean stainless steel panels with stainless steel cleaner.

## **Service**

### **Ice machine operation (all models)**

Follett's ice machine consists of four distinct functional systems:

- Harvesting system
- Refrigeration system
- Water system
- Electrical control system

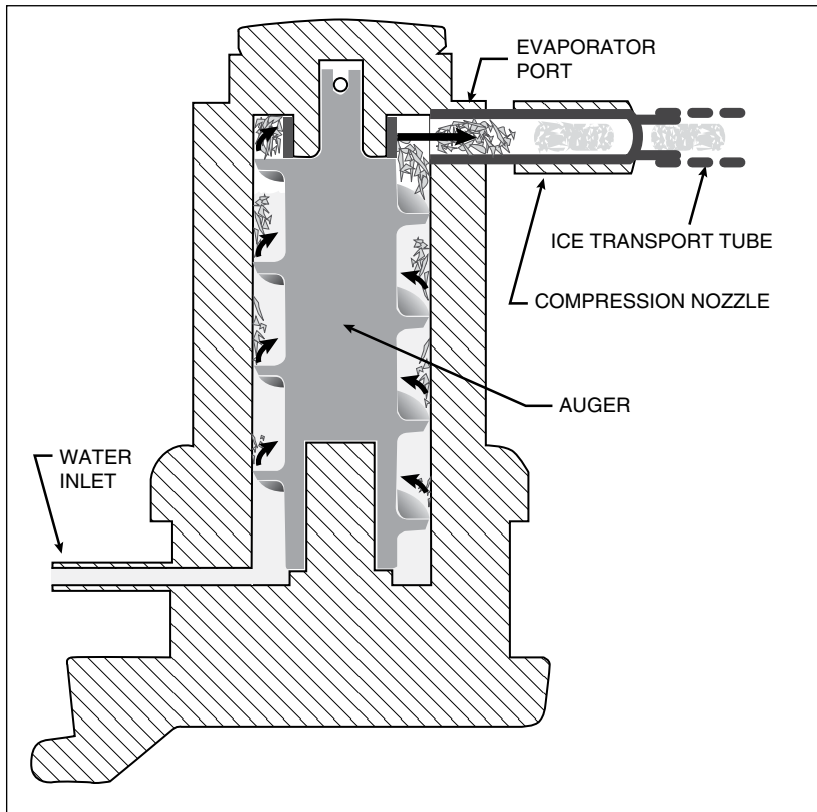
These four systems work together to accomplish the production and harvesting of ice. A problem in any one of these systems will result in improper operation of the entire ice production cycle. When troubleshooting the ice machine, it is important to analyze the entire system operation to determine which system is not functioning properly, then pinpoint the component within that system that is malfunctioning. Determine what corrective action must be taken before making any adjustments or replacing any components.

### **The icemaking process**

The Maestro Plus ice machine uses a stainless steel jacketed evaporator and operates on a continuous freezing cycle. Water is supplied to the evaporator from the water reservoir where the water level is controlled by conductivity probes.

When the ice machine is running, a layer of ice forms on the interior surface of the evaporator. This ice is continuously removed by a slowly rotating (10 RPM) auger. The auger carries the ice upward into the cavity formed by the top bearing housing and the compression loop, where it is compressed to remove excess water. When the ice reaches the desired hardness it rotates within the cavity and is forced through a discharge port and compression nozzle and into the ice transport tube. The discharge tube and compression nozzle are slightly restricted to further compress the ice and produce the desired hardness.

A solid state control board located in the electrical box of the ice machine controls the normal operation of the ice machine and monitors gearmotor torque. This control board will shut down the ice machine should an over-torque condition occur. It is very important that you familiarize yourself with the operational sequences detailed in this manual before attempting to service the ice machine.



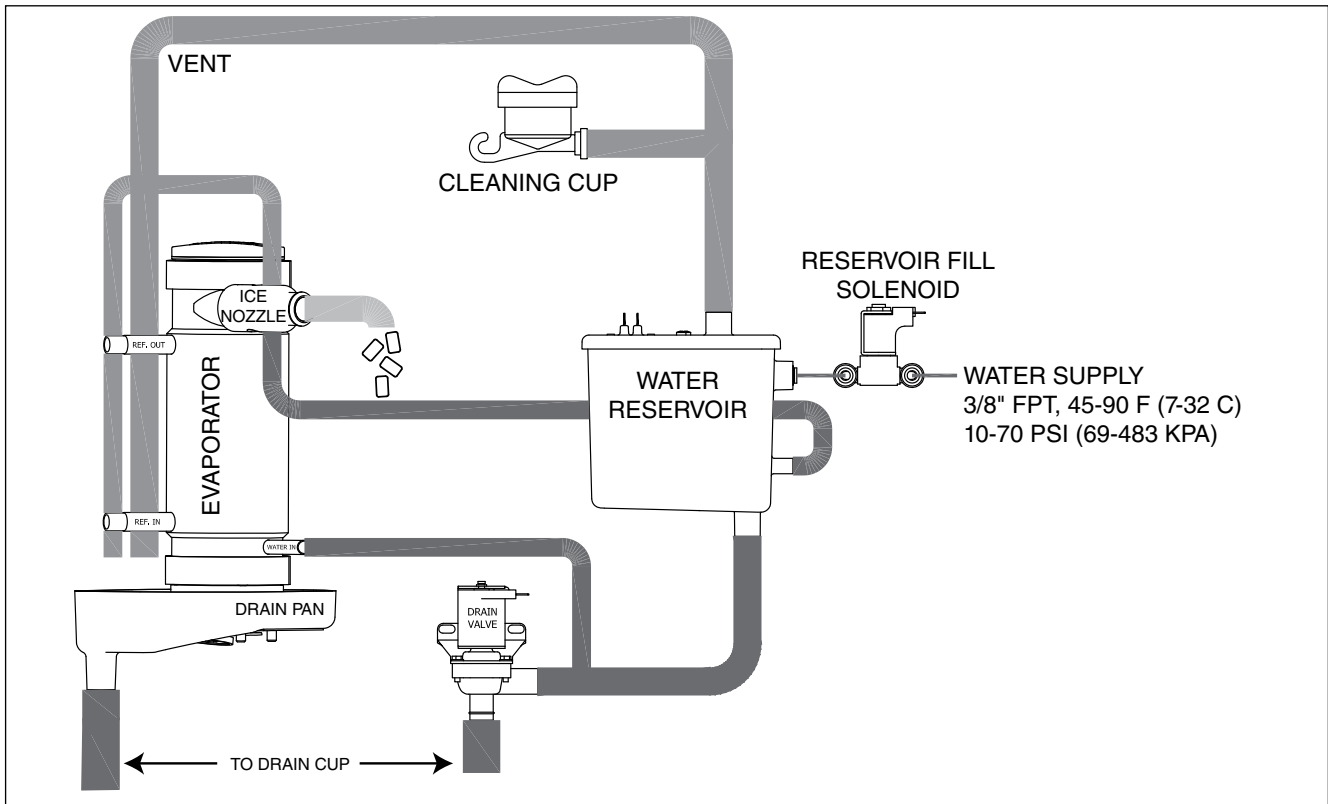
## Water system

The water level in the evaporator is controlled by a fill solenoid (**Fig. 14**) and level detecting sensors. Water sensing rods (**Fig. 15**) extend down into the reservoir at the end of the evaporator assembly. The system works via electrical conductivity as follows:

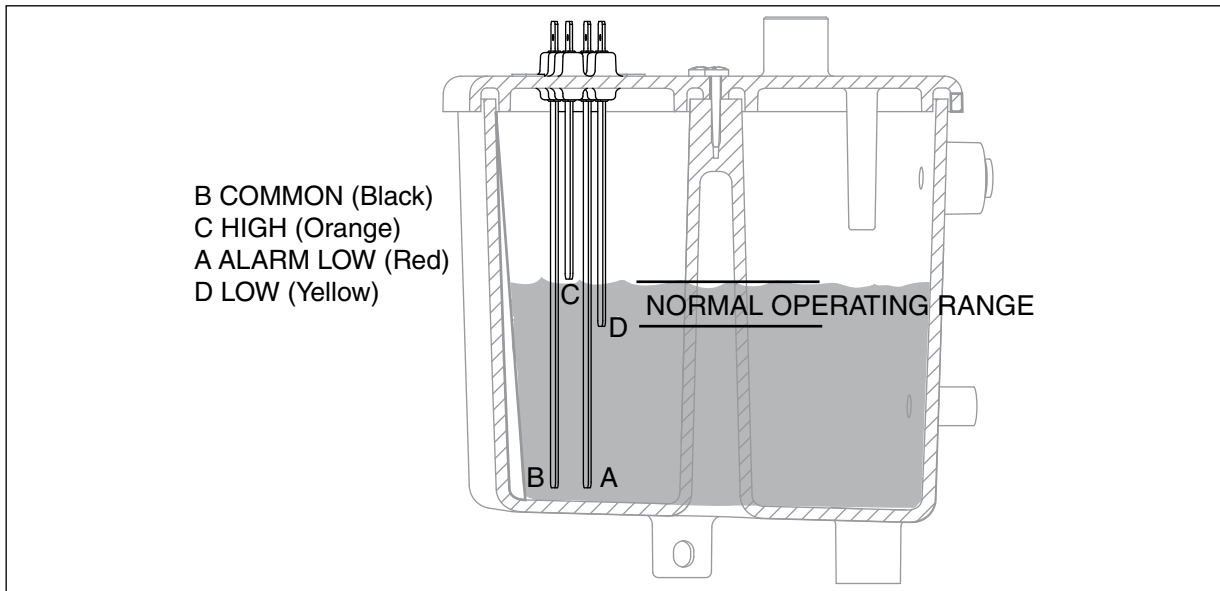
One of the longest probes is a common. When water is between any of the other probes and the common, the PC board will sense the activation. During normal operation, the water level rises and falls between the Normal High and Normal Low sensors. As water is consumed to make ice, the level will fall until the Normal Low sensor is exposed, triggering the water feed solenoid on. Water will fill until the Normal High sensor is activated.

**Note:** The potable water dissolved solids content must be greater than 10 ppm for the water control system to function properly. If using reverse osmosis water filtration system, ensure T.D.S level is greater than 10 ppm.

**Fig. 4 – Water system diagram**

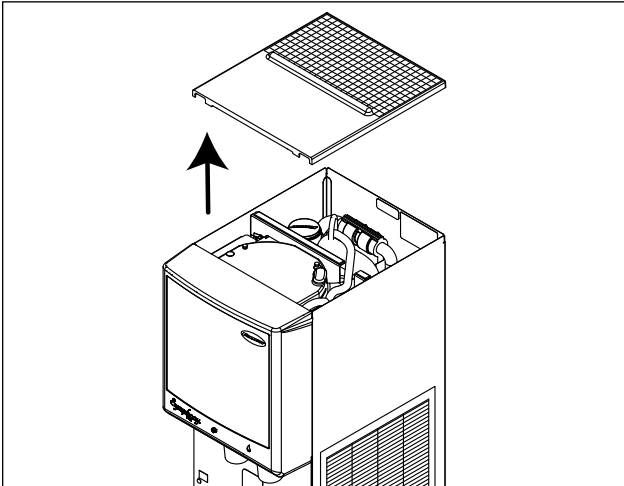


**Fig. 5 – Water level diagram**



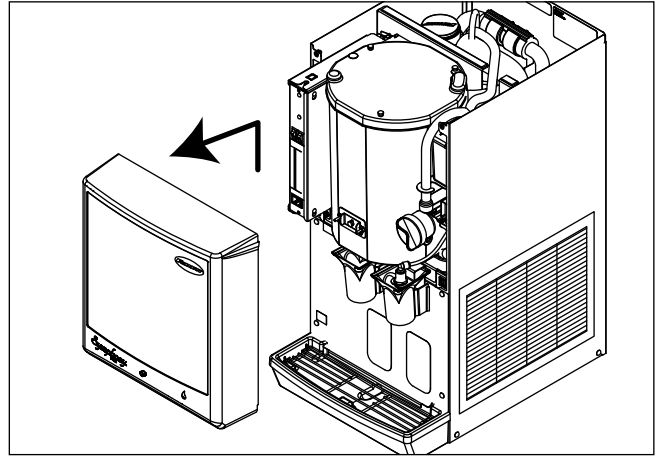
## Panel removal

Fig. 6



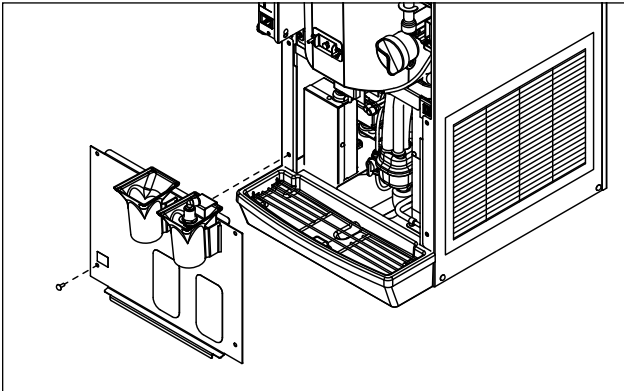
**Top cover:** Lift cover up and off Velcro strips.

Fig. 7



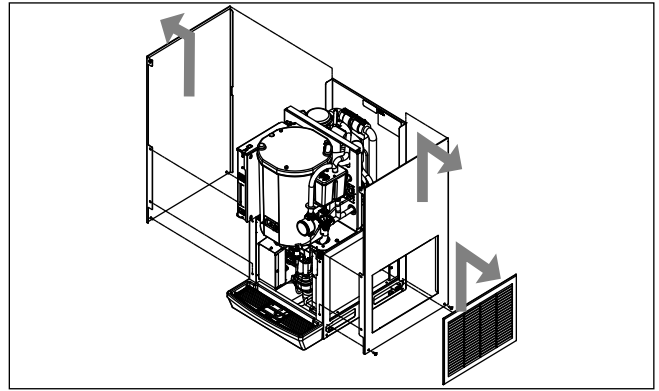
**Front cover:** Pull bottom of cover, then lift cover up and forward to unhook from keyhole slots.

Fig. 8



**Splash panel:** Remove 4 screws. Pull out bottom of panel to allow top to slide out from under hopper support lip.

Fig. 9



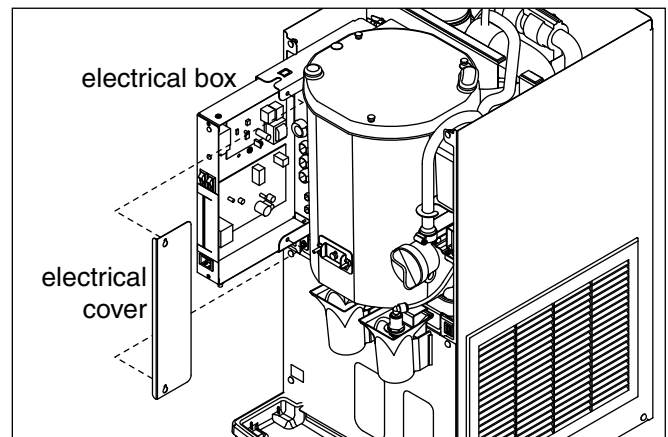
**Side panels:** Remove screws. Lift panel to disengage from back panel, then remove. Note: Before removing right hand side, remove side louver panel by lifting up and pulling forward on panel.

### Access to electrical box and control board

The 12 series electrical box has been designed to slide out for easy access to the control board and more convenient troubleshooting.

1. Remove top and front panels of dispenser.
2. Remove electrical box cover.
3. Pull electrical box toward front of unit.

Fig. 10



## Electrical system



### ATTENTION!

To prevent circuit breaker overload, wait 15 minutes before restarting this unit. This allows the compressor to equalize and the evaporator to thaw.

### Normal control board operation

The PC board indicator lights provide all the information necessary to determine the machine's status. Green indicator lights generally represent "go" or normal operation; Yellow indicators represent normal off conditions; Red indicators generally represent alarm conditions, some of which will lock the machine off.

A flashing green light labeled POWER indicates power to the machine. All other normal operation status indicators are covered as follows:

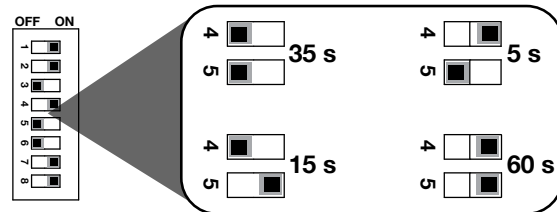
Ice machine disposition	Operating conditions
<b>Legend:</b> ● ON    ○ OFF    ◐ ON or OFF    ✖ FLASHING	
1. Ice machine is making ice. CLEANER FULL ○ DRAIN CLOG ○ HI PRESS ○ HI AMPS ○ SERVICE ○ MAINT/CLEAN ○ LOW WATER ○ TIME DELAY ○ SLEEP CYCLE ○ MAKING ICE ● LOW BIN ● POWER ON ✖	1. <b>Normal running.</b>
2. Ice machine is not making ice. CLEANER FULL ○ DRAIN CLOG ○ HI PRESS ○ HI AMPS ○ SERVICE ○ MAINT/CLEAN ○ LOW WATER ○ TIME DELAY ● SLEEP CYCLE ○ MAKING ICE ○ LOW BIN ● POWER ON ✖	2. <b>Normal time delay.</b> When the bin fills with ice, the LOW BIN light goes out momentarily and the refrigeration and auger drive systems immediately shut down. ( <b>Note:</b> The fan motor will continue to run for 10 minutes to cool condenser) The TIME DELAY light comes on, initiating the time delay period. When the time delay expires, the machine will restart provided that the LOW BIN light is on.

### Control board DIP switch settings

OFF POSITION     ON POSITION

	OFF	ON	
Not used	<input type="checkbox"/>	<input checked="" type="checkbox"/>	Not used
Sleep cycle disabled	<input type="checkbox"/>	<input checked="" type="checkbox"/>	Sleep cycle enabled
SensorSAFE	<input type="checkbox"/>	<input checked="" type="checkbox"/>	Lever
Sleep cycle dispense duration	<input type="checkbox"/>	<input checked="" type="checkbox"/>	Sleep cycle dispense duration
20 min. time delay	<input type="checkbox"/>	<input checked="" type="checkbox"/>	60 min. time delay
Flush disabled	<input type="checkbox"/>	<input checked="" type="checkbox"/>	Flush enabled
Maint. timer ON	<input type="checkbox"/>	<input checked="" type="checkbox"/>	Maint. timer OFF

### Sleep cycle dispense duration



### Relay/triac output indication

Each relay on the board has an indicator light associated with its output. For example, when the relay for the water feed solenoid is energized, the adjacent indicator light glows green.

### Flushing logic

**Off cycle:** At the completion of off-cycle time delay, the machine checks for a cumulative one (1) hour of ice making time since the last off-cycle flush. If the cumulative ice making time exceeds one (1) hour, the machine will open the drain valve for 60 seconds to drain the evaporator in its entirety. It will then refill with water, flush again and refill, and begin making ice. If the ice making time is less than 1 hour, the machine will start and begin making ice without draining the evaporator.

### Error faults

The Maestro Plus PC board monitors various operating parameters including high pressure, auger gearmotor amperage limits, clogged drain, and low water alarm conditions. There are two types of errors namely “hard” or “soft.” A hard error is one that shuts the machine off and will not allow restart until the reset button is pressed. Even cycling power will not reset a hard error. A soft error can either be automatically reset should the condition rectify, or if power is cycled. Should an error occur, consult the troubleshooting guide in this manual or a Follett service technician.

#### Soft errors:

**Note:** For all soft errors, the ice machine will remain off for 1 hour.

**LO WATER:** During operation, the water level cycles between the normal low and normal high sensors. Should the water be shut off to a running machine, a soft error will occur. The error sequence is as follows: During operation, the water level falls to the normal low sensor, and when it does the water feed solenoid is energized. If water is not detected at the normal low sensor within 10 seconds, a soft error will occur. The machine will shut down and TIME DELAY and LOW WATER LEDs will be lit. After time delay, the solenoid will energize and remain energized until the water level is sufficient for restart.

**HI PRESSURE:** Should the refrigeration pressure rise above 425 psi, the machine will shut down and the TIME DELAY and HIGH PRESSURE will be illuminated. After the time delay, and if the pressure has fallen back below the reset point of 295 psi, the machine will restart and the TIME DELAY and HIGH PRESSURE will clear.

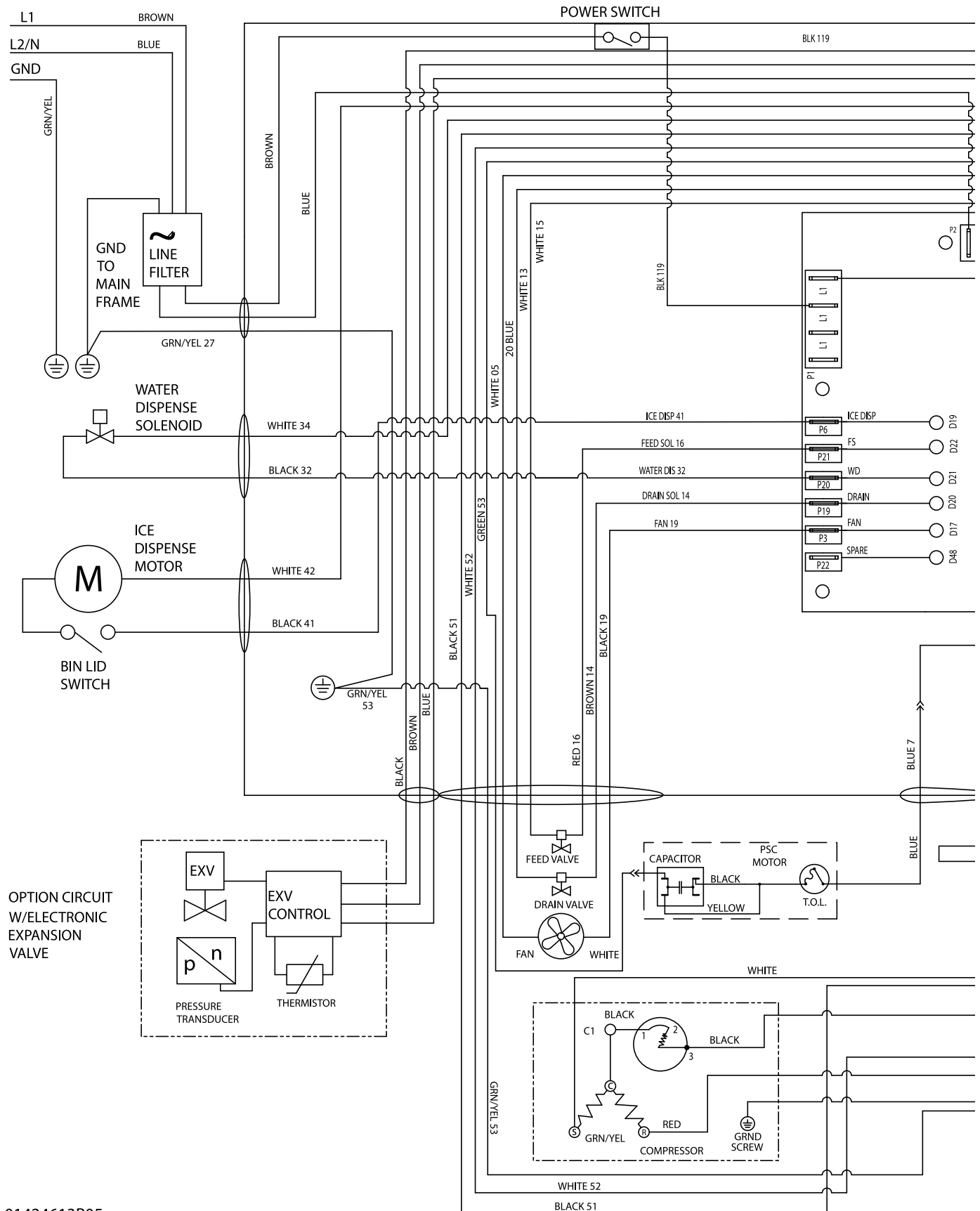
**HI AMPS:** The PC board monitors the amperage of the auger motor. Should the gear motor experience current draw above the allowable 1.8A limit or no current draw (0A), the machine will shut down and the TIME DELAY and HI AMP will be illuminated. After the time delay the machine will restart and the TIME DELAY and HI AMP will clear.

#### Hard error:

**HI AMPS:** If a second hi-amp error occurs within 1 hour of the initial hi-amp error, the ice machine will shut off and the reset on the board must be pressed to clear the error. If a second hi-amp has occurred, the HI AMP LED only will be illuminated.

**DRAIN CLOG:** The drain clog sensor, located in the evaporator drain pan will detect the presence of water just below the top edge of the pan. If water does not properly flow out of the internal or external drain lines it will backup into the drain pan (especially during a self-flushing purge cycle). Pressing the reset button will restart the ice machine.

# Wiring diagram - 230 V 50 Hz



01424613R05





## Ice machine operational and diagnostic sequences

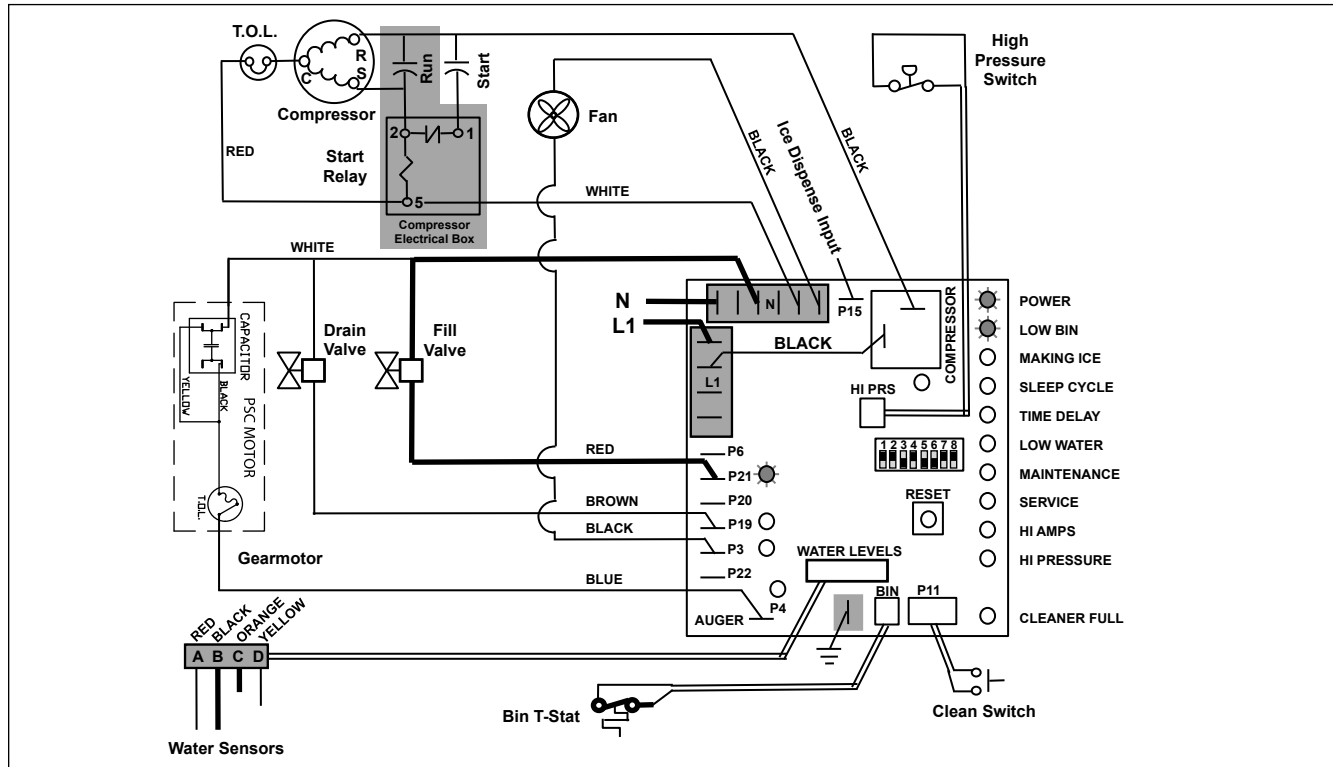
The wiring diagrams that follow illustrate the circuitry of Follett ice machines used with 12 series ice dispensers. Both normal operation (stages 1–8) and non-normal diagnostic sequences showing torque-out for use in troubleshooting are shown.

### Circuitry notes

- Bin signal is contact closure only - **DO NOT SUPPLY POWER.**

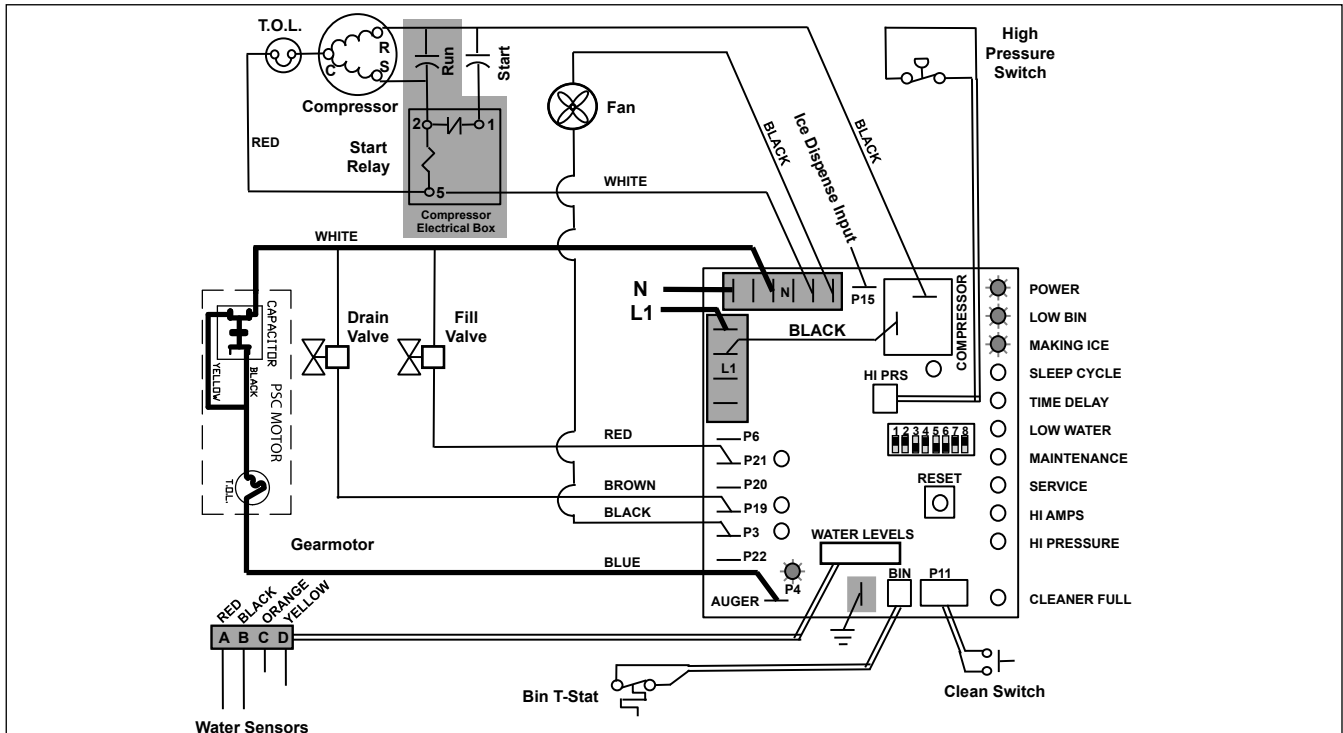
### Normal operation – Stage 1

Power is supplied to L1 of the control board, the **POWER** LED light begins flashing. The ice level bin thermostat in the dispenser is closed and calling for ice, supplying contact closure to the control board. The **LOW BIN** LED will be on. The control board will now go through the start-up sequence. The board checks the water sensors (located in the reservoir) for continuity between the common probe (B) and the high probe (C). If continuity is not sensed, the water fill valve (P21) is energized.



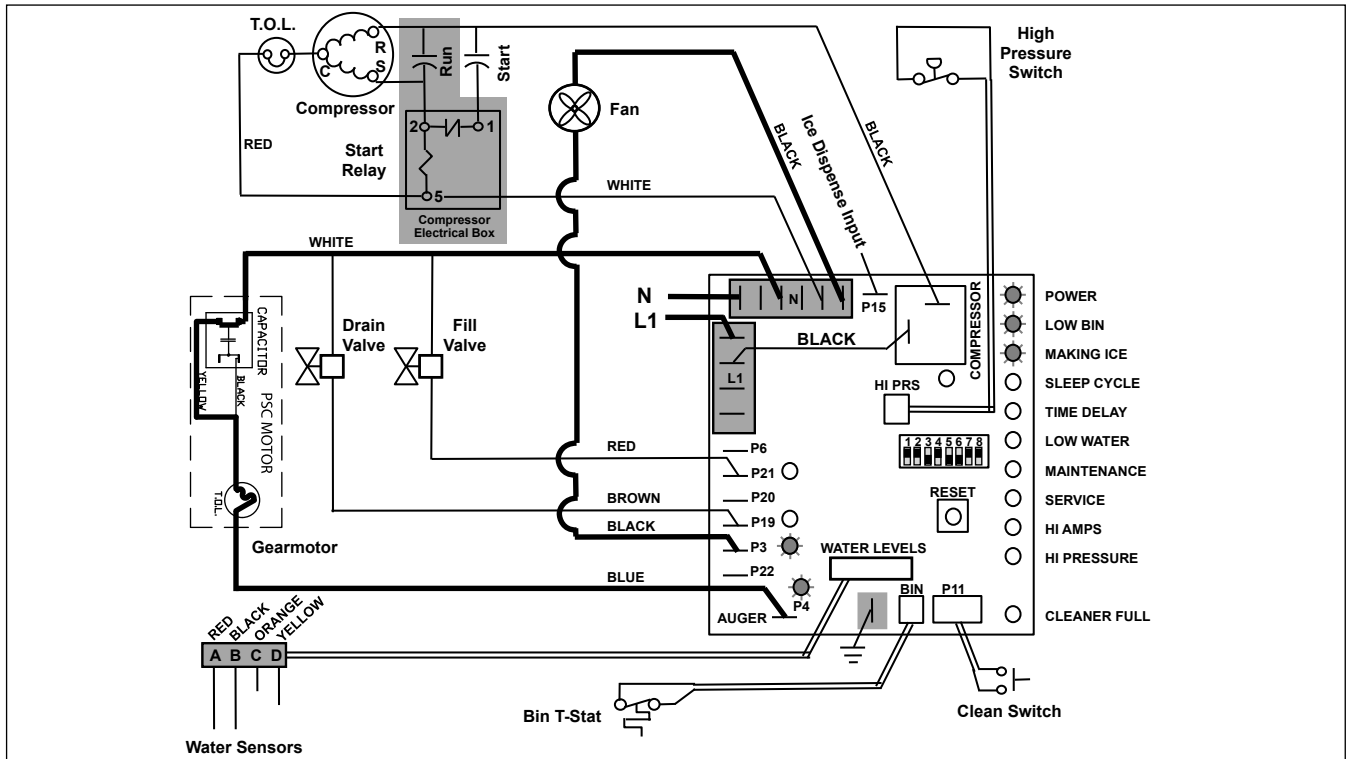
### Normal operation – Stage 2

When continuity is seen between B and C, the water valve de-energizes, the AUGER output (P4) comes on along with the **MAKING ICE** LED. The auger gearmotor's start windings are energized through a run capacitor that is pulled in by the initial high current draw of the gearmotor.



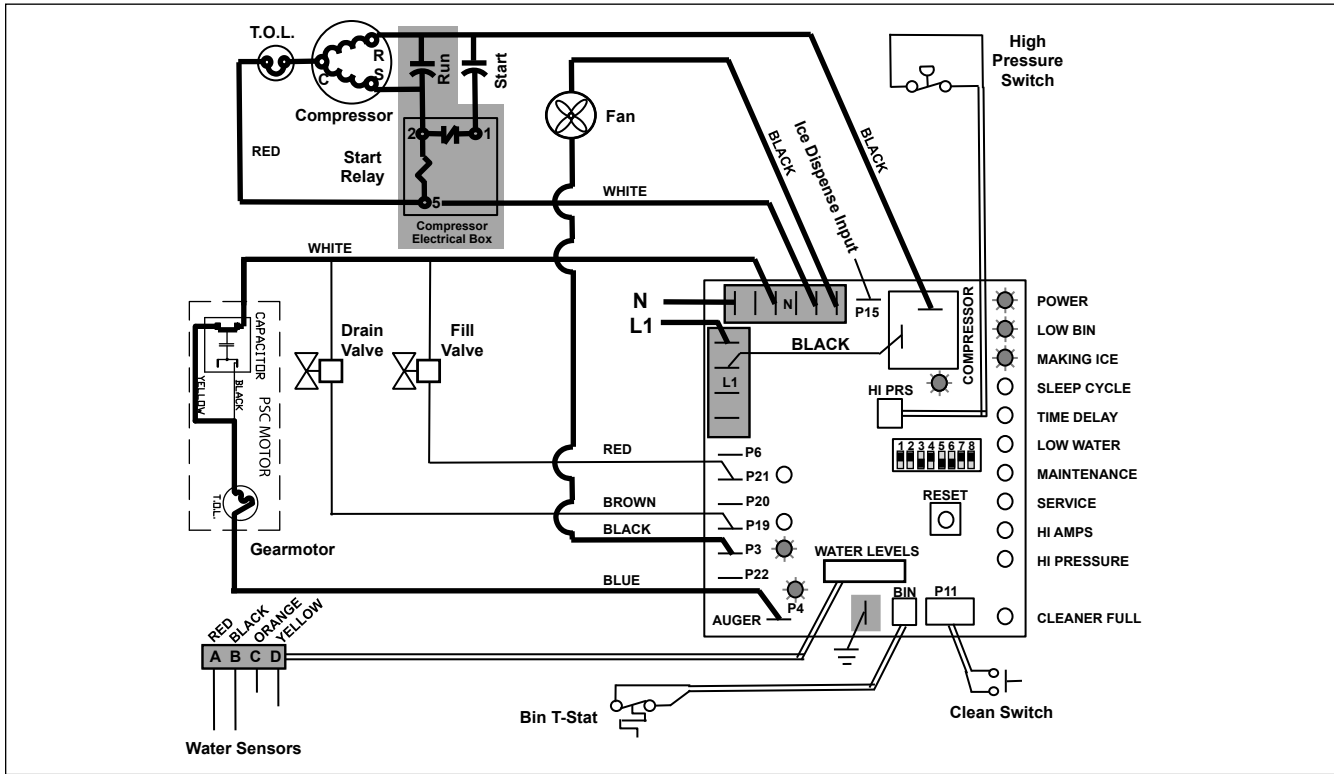
### Normal operation – Stage 3

After the initial high current draw drops off, the gearmotor start windings stay energized. The condenser fan output (P3) comes on 0.5 seconds later.



### Normal operation – Stage 4

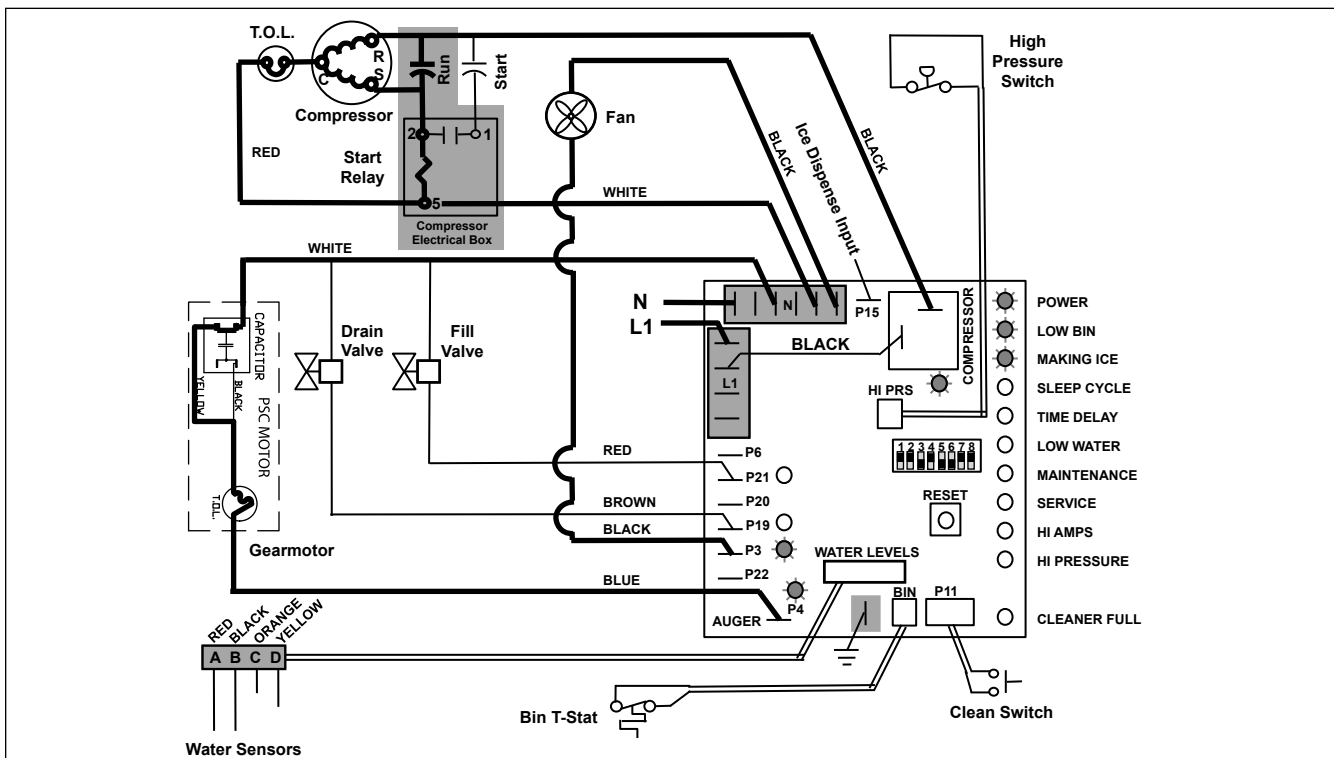
One second (1 s) after the fan comes on, the **COMPRESSOR** output comes on. The compressor circuit uses both run and start capacitors along with a potential start relay. The start capacitor is energized through the normally closed contacts of the start relay.



### Normal operation – Stage 5

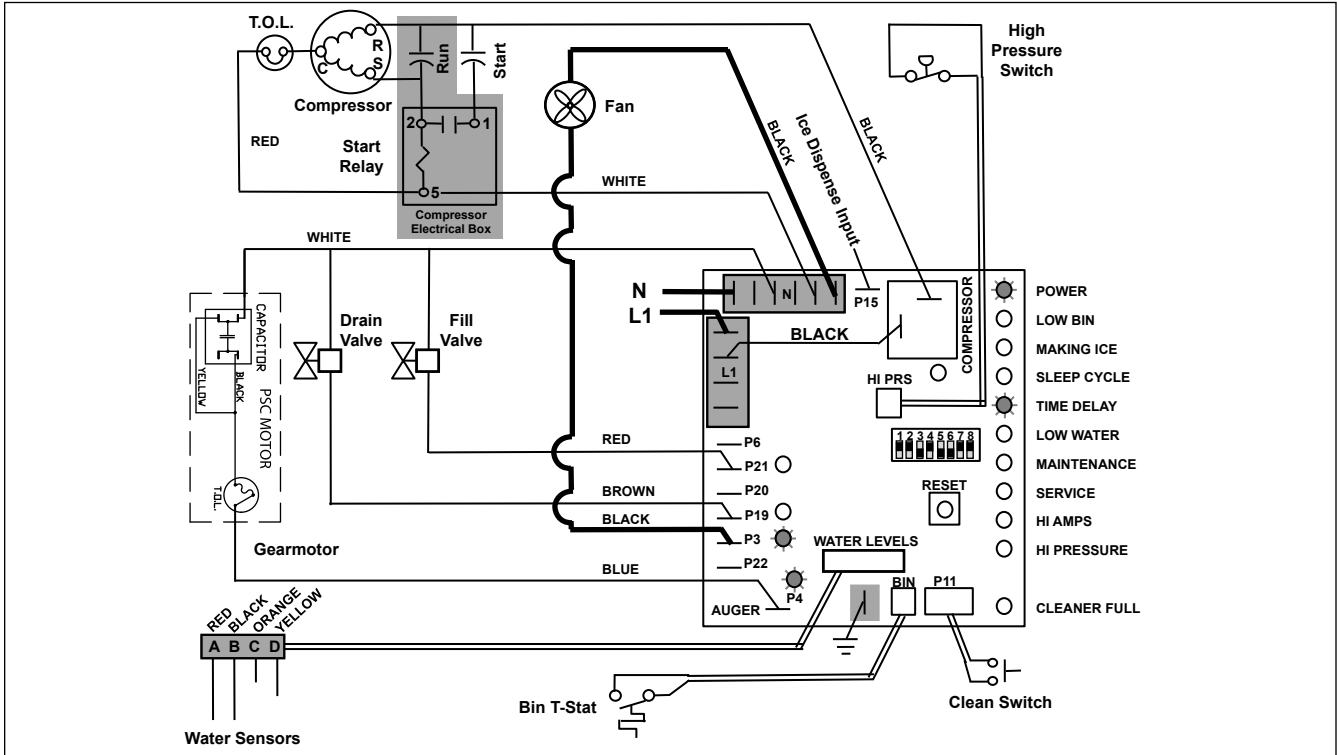
As the compressor comes up to normal running speed, its start winding generates a voltage potential across the relay's coil. This energizes the coil to open the contact and drop out the start capacitor.

The ice machine is now in a normal ice making mode. The ice machine will produce ice until the bin level control in the ice dispenser is satisfied.



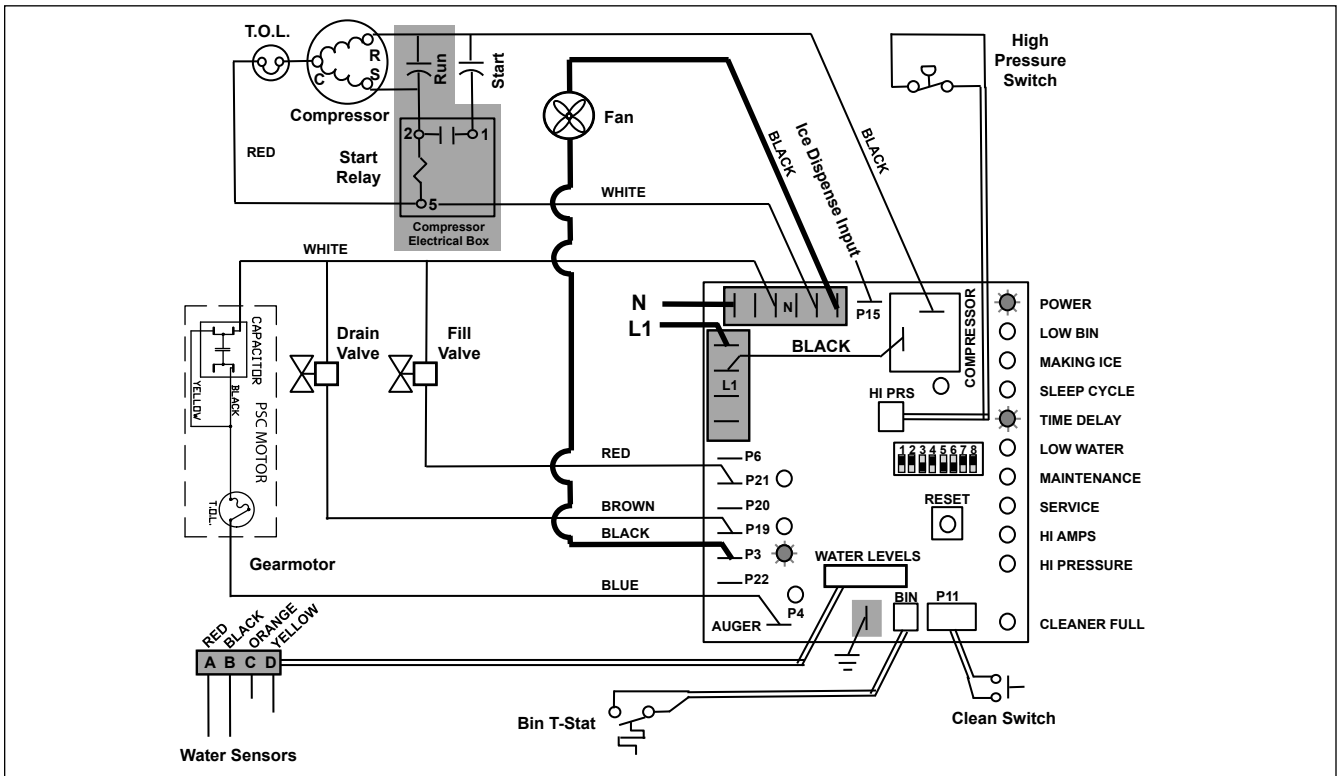
### Normal operation – Stage 6

Once the bin thermostat control opens, the **LOW BIN** LED goes out. After a 10 second delay the compressor output turns off, the **MAKING ICE** LED goes out and the **TIME DELAY** LED comes on.



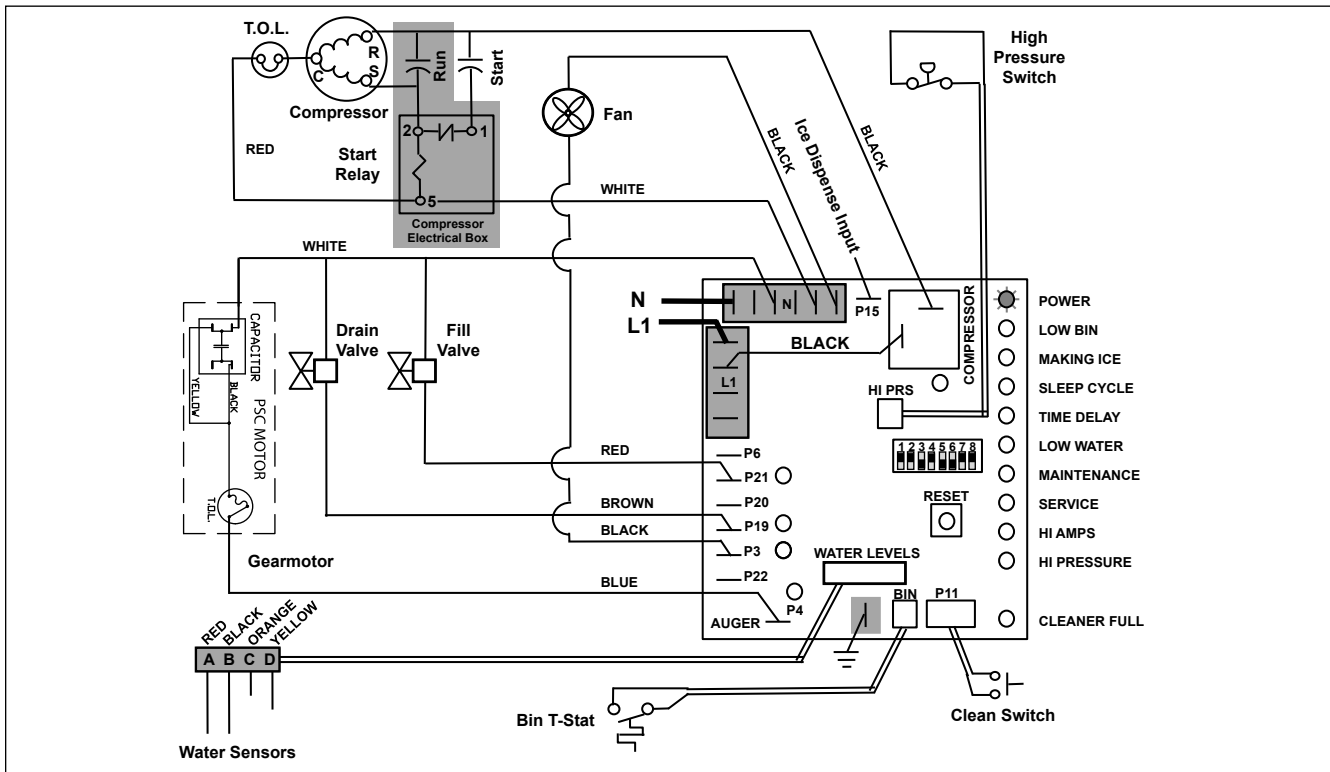
### Normal operation – Stage 7

The fan motor continues for 10 minutes before shutting off. The **TIME DELAY** LED remains on for 20 minutes. The ice machine will not start while the **TIME DELAY** LED is on. To restart the ice machine for troubleshooting purposes, depress the reset button to clear the control board.



## Normal operation – Stage 8

When the dwell time of 20 minutes has expired, the **TIME DELAY** LED goes off. If 5 seconds of ice has been dispensed and the **SLEEP CYCLE** LED is off, the ice machine will go through the normal start-up sequence when the bin level control signals the control board for ice.

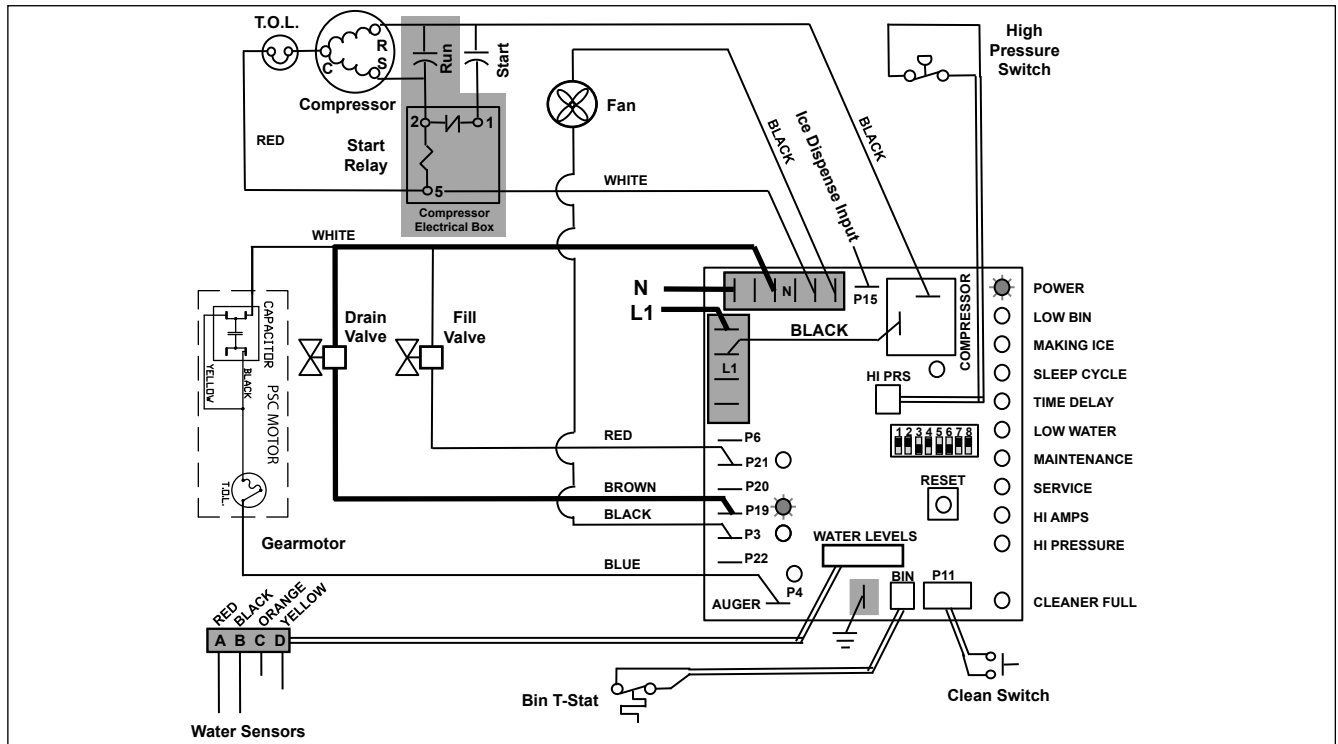


## Quiet Night™/Sleep cycle

The board monitors ice dispensing through a line voltage input to P15. If the ice dispense has not be initiated for more than 5 seconds during the 20 minute time delay, the **SLEEP CYCLE** LED comes on. The machine will stay off for 12 hours unless 5 seconds of dispensing is seen. After 12 hours, the **SLEEP CYCLE** LED goes out and the ice making will resume if the bin thermostat is closed. The sleep cycle dispense duration is adjustable using the DIP switches on the control board.

## Self-flushing

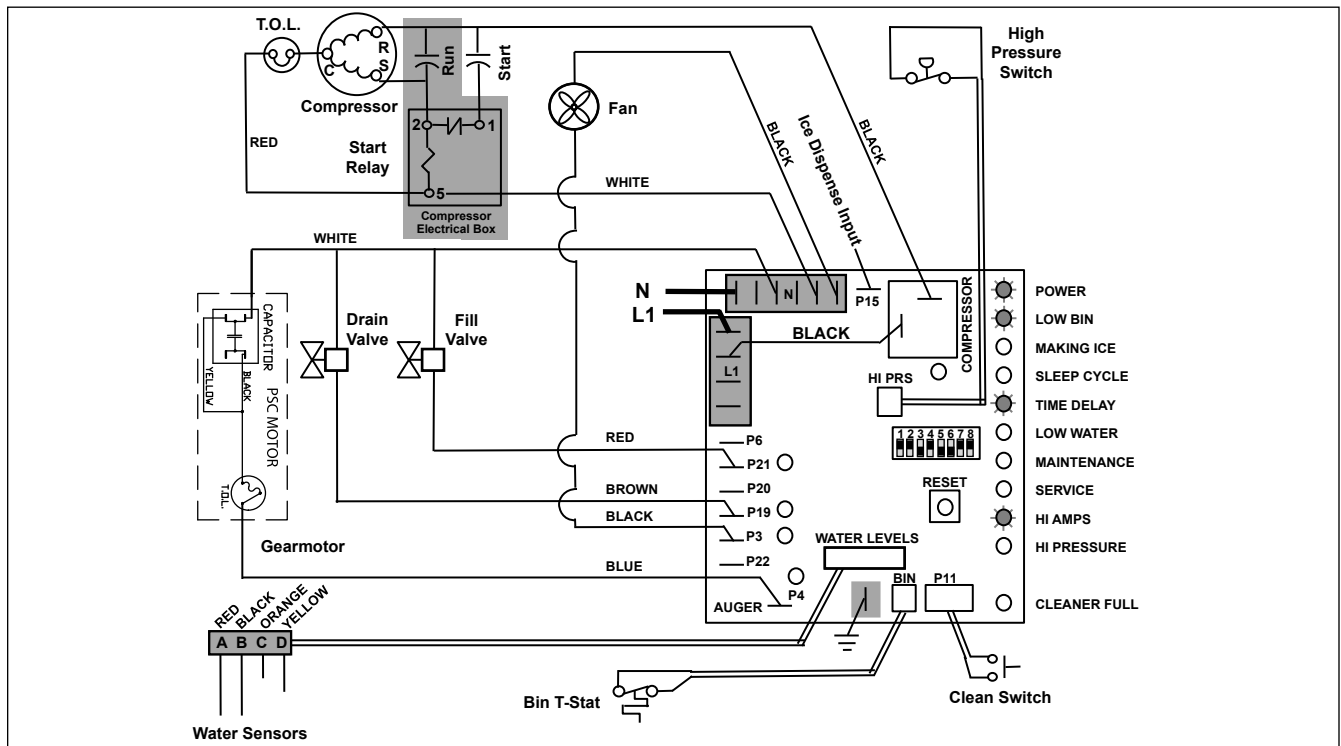
At the completion of the 20 minute time delay, the machine checks for a cumulative one hour of ice making time since the last off-cycle flush. If the cumulative ice making time exceeds one hour, the machine will energize the drain valve P19 for 60 seconds to drain the evaporator. It will then refill with water, flush again, refill and begin making ice if the **LOW BIN** LED is on. If the ice making time is less than 1 hour, the machine will start and begin making ice without draining the evaporator.



## Diagnostic stages

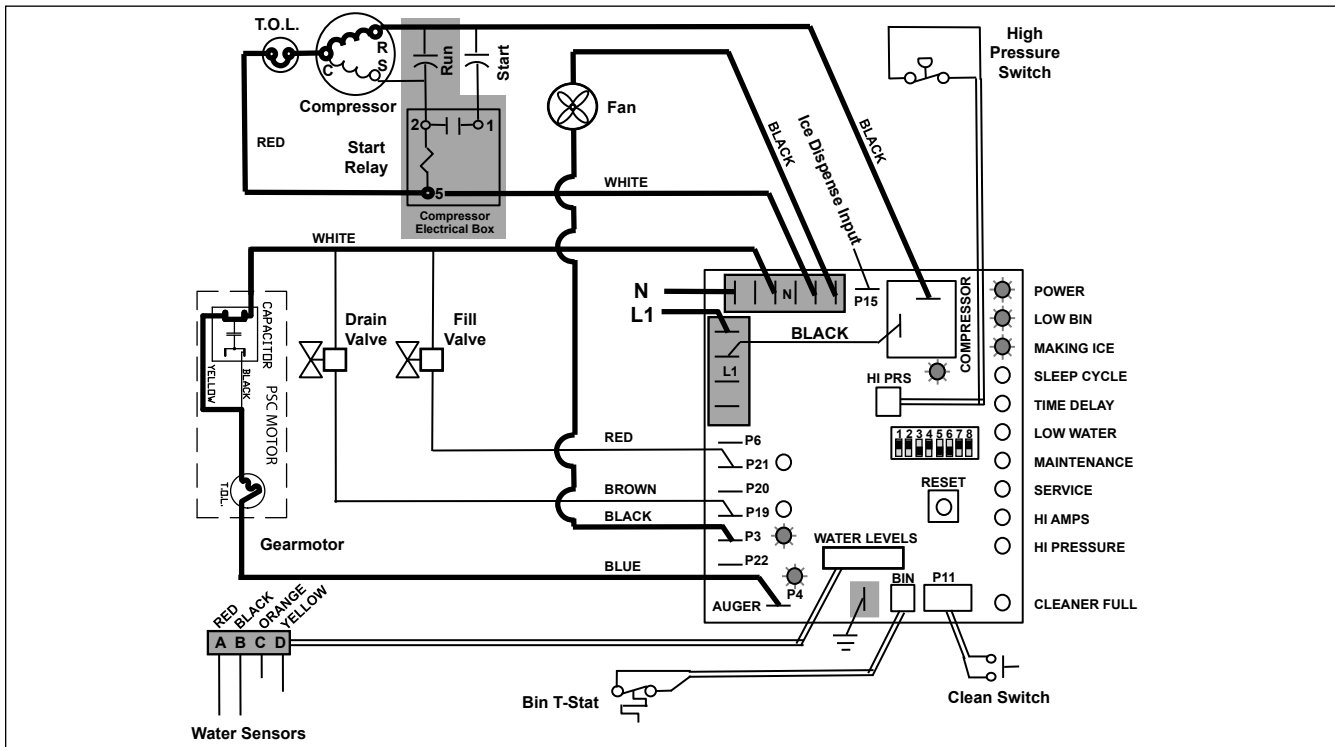
### High gearmotor amps – Stage 1

The **HI AMPS** error and **TIME DELAY** LEDs are on indicating that the control board has sensed an over-torque condition at the P4 terminal (more than 3A from the gearmotor) or no current draw (0A) and shut the ice machine down (strike one). The **HI AMPS** and **TIME DELAY** LEDs will remain on for 60 minutes after an over-torque condition has occurred. The ice machine will remain off as long as these two LEDs are on. After the 60 minute time delay, these LED lights turn off, and the control board will try to go through a normal start-up sequence.



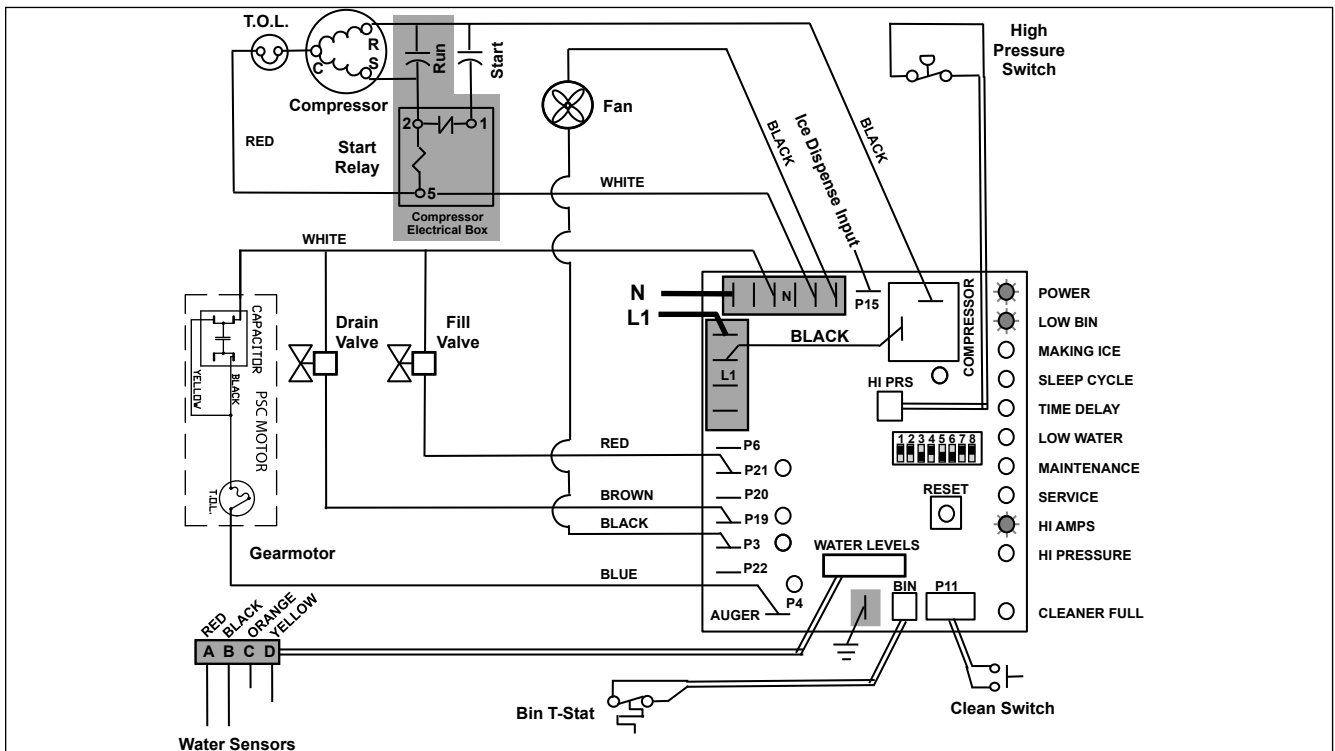
## High gearmotor amps – Stage 2

If the restart is successful the board will continue to monitor the current draw on P4 for 60 minutes looking for a second high amps (above 1.8A) or no current draw (0A) occurrence. If the ice machine runs without problems for 60 minutes and no additional torque errors occur, the ice machine will continue normal operation.



## High gearmotor amps – Stage 3

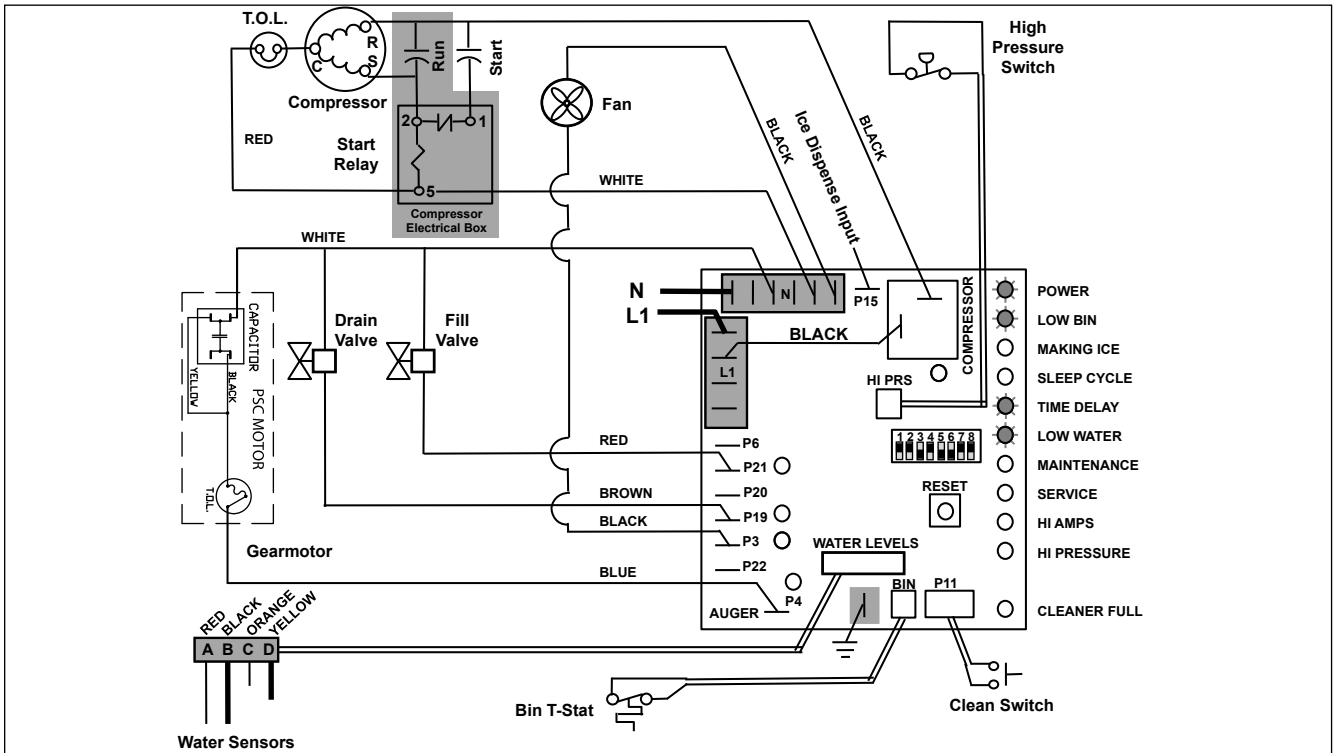
If a second occurrence happens during the 60 minute monitoring period, the **HI AMPS** LED will come on again and shut the machine down (strike two). The **HI AMPS** LED (without the **TIME DELAY** LED) will indicate to the technician that two consecutive over-torque situations have occurred. The ice machine is shut down at this time and locked out. It will not restart unless the manual reset button is depressed while power is on.





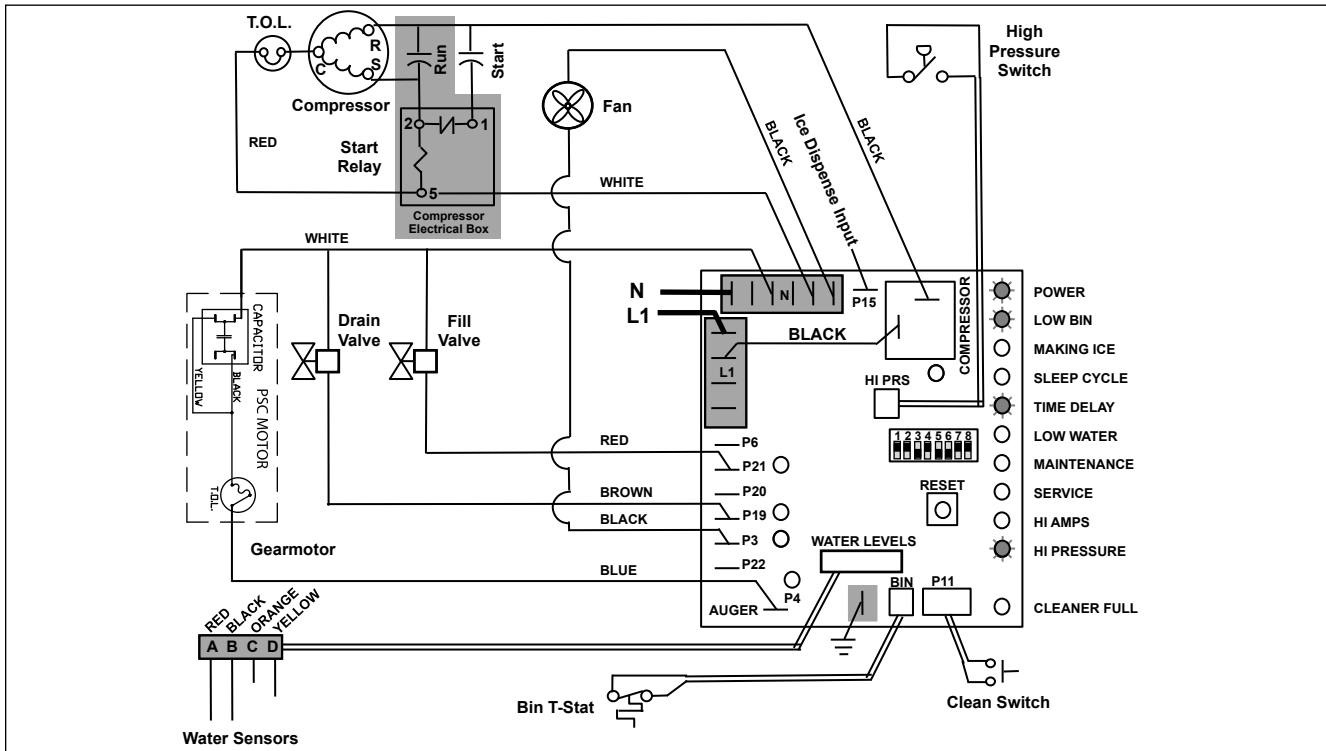
### Loss of water

During operation, the water level cycles between the normal low (D) and normal high (C) water probes - the fill valve (P21) cycling on and off. If continuity is not detected between the common probe (B) and normal low (D) within 10 seconds, the **LOW WATER** and **TIME DELAY** LEDs will come on and the machine will shut down for the one hour time delay period. After the time delay, the fill valve will re-energize and wait for continuity between the common probe and normal high before restarting. **LOW WATER** LED will remain ON until the water level is satisfied.

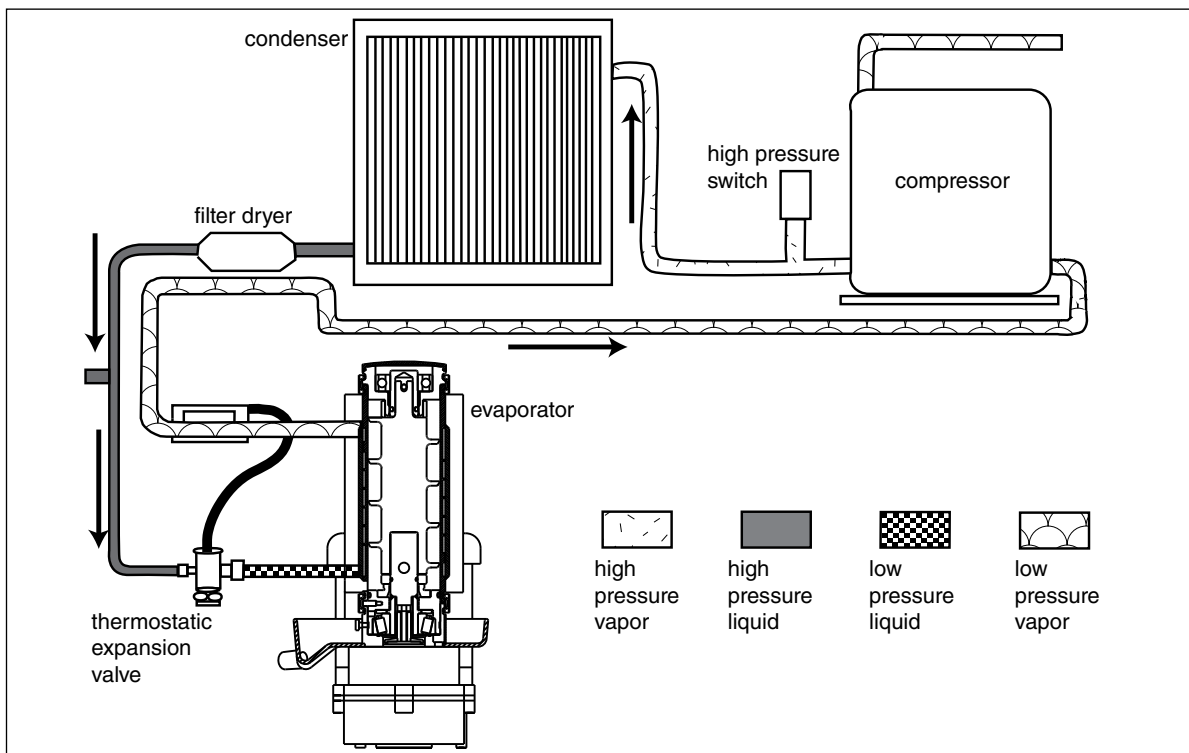


## High refrigerant pressure

Should the refrigeration pressure rise above 425 psi, the high pressure switch contacts will open. The board sees the open circuit and the **HIGH PRESSURE** and **TIME DELAY** LEDs will come on, the machine shuts down. After the one hour time delay, the machine will attempt to restart. If the pressure has fallen below the reset point of 295 psi and the board see the contacts closed, the machine will resume normal operation. If the contacts are still open after the restart, the board will again go into **HIGH PRESSURE** and **TIME DELAY**, cycling until contact closure is seen.



## Refrigeration cycle



## Refrigeration pressure data

### Air-Cooled ice machine capacity/24hrs

Ambient Air Temperature F/C

	Ambient Air Temperature F/C						
	F	60	70	80	90	100	
	C	16	21	27	32	38	
Inlet Water Temperature F/C	50	418	388	357	325	294	lbs.
	10	189	176	162	147	129	kg.
	60	395	370	345	313	281	lbs.
	16	179	168	156	142	127	kg.
	70	372	353	334	301	268	lbs.
	21	169	160	151	137	122	kg.
	80	362	340	318	288	259	lbs.
	27	164	154	144	131	117	kg.
	90	352	327	302	275	249	lbs.
	32	160	148	137	125	113	kg.

## Compressor data

Air-cooled				
Ambient air temperature	50 F/10 C	70 F/21.1 C	90 F/32.2 C	110 F/43.3C
	230 V	230 V	230 V	230 V
Amperage	2.2	2.3	2.5	2.6
High-side pressure (PSIG)	112	152	202	260
Low-side pressure (PSIG)	18.5	21	25	30

Locked rotor amps: 230 V: 18.2A

## Gearmotor data

Gearmotor data	230 V/50 Hz
Gearmotor current	1.3A (nominal)

## Refrigeration system

**Important:** All service on refrigeration system must be performed in accordance with all federal, state and local laws that pertain to the use of refrigerants. It is the responsibility of the technician to ensure that these requirements are met.

### E414 ice machine charge specifications

Model	Charge	Refrigerant type
E12CI414A (air-cooled)	3.52 oz (100 grams)	R290

### Refrigerant replacement requirements

1. Non-contaminated refrigerant removed from any Follett refrigeration system can be recycled and returned to the same system after completing repairs. Recycled refrigerant must be stored in a clean, approved storage container. If additional refrigerant is required, virgin or reclaimed refrigerant that meets ARI standard 700-88 must be used.
2. In the event of system contamination (for example, a compressor burn out, refrigerant leak, presence of non-condensibles or moisture), the system must be repaired, evacuated and recharged using virgin or reclaimed refrigerant that meets ARI standard 700-88.
3. Follett LLC does not approve of recovered refrigerants. Improper refrigeration servicing procedures will void the factory warranty.

### Evacuation

Evacuate the system to a level of 500 microns. When the 500 micron level is reached, close valves and both manifold and shut down the vacuum pump. Allow the system to sit for approximately 20 minutes. During this period the system pressure should not rise. If the system pressure rises and stabilizes there is moisture in the system and further evacuation is needed. If the pressure continues to rise check the system for leaks.

### Ice capacity test

Ice machine production capacity can only be determined by weighing ice produced in a specific time period.

1. Remove top panel and hopper lid of unit.
2. Weigh and record weight of container used to catch ice.
3. Run ice machine for at least 15 minutes.
4. Catch ice for 15 or 20 minutes.
5. Weigh harvested ice and record total weight.
6. Subtract weight of container from total weight.
7. Convert fractions of pounds to decimal equivalents (Ex. 6 lbs 8 oz = 6.5 lbs).
8. Calculate production using following formula:

$\frac{1440 \text{ min.} \times \text{wt. of ice produced}}{\text{Total test time in minutes}} = \text{Production capacity/24 hr. period}$
--

9. Calculated amount per 24 hours should be checked against rated capacity for same ambient and water temperatures in Ice Production Table (see page 32).

# Dispenser troubleshooting



- Disconnect power to unit before putting hands or arms in storage area or attempting any repair or service to equipment.

### Before calling for service

1. Check that no ice is in the dispenser bin area.
2. Check that congealed ice is not causing a jam.
3. Check that all switches and circuit breakers are on.
4. Check that all drains are clear.
5. Check that water is supplied.

### Lever model troubleshooting guide

Problem	Indicators	Corrective Action
Does not dispense ice.	<ol style="list-style-type: none"> <li>1. Power switch off or faulty.</li> <li>2. Faulty dispense switch.</li> <li>3. Wheel motor malfunction.</li> <li>4. Defective control board.</li> <li>5. Defective wiring.</li> </ol>	<ol style="list-style-type: none"> <li>1. Turn on or replace the defective switch.</li> <li>2. Replace defective switch.</li> <li>3. Verify voltage at motor and replace wheel motor if defective.</li> <li>4. Jumper pins 1 &amp; 2 on connector P13.               <ol style="list-style-type: none"> <li>a. Control board output LED, D19 should light. Replace board, if D19 does not come on.</li> <li>b. D19 comes on but no voltage at wheel motor. Move connector from P6 to L1, if motor runs, replace control board.</li> </ol> </li> <li>5. Ohm check wiring going from lever switch to P13 pins 1 &amp; 2. Ohm check wiring from P6 to wheel motor and neutral wire to neutral on control board. Repair or replace as needed.</li> </ol>
Dispense wheel rotates continuously.	Dispense switch contacts are welded together.	Replace dispense switch.
Ice machine runs continuously.	Faulty or incorrectly positioned bin thermostat.	Check for proper positioning. If thermostat does not open when ice is placed on capillary tube, replace thermostat.
Does not dispense water.	<ol style="list-style-type: none"> <li>1. Power switch off/faulty.</li> <li>2. Faulty water dispense switch.</li> <li>3. Water dispense solenoid malfunction.</li> <li>4. Defective control board.</li> <li>5. Defective wiring.</li> </ol>	<ol style="list-style-type: none"> <li>1. Turn on or replace the defective switch.</li> <li>2. Replace defective switch.</li> <li>3. Verify voltage at water dispense solenoid and replace water dispense solenoid if defective.</li> <li>4. Jumper pins 3 &amp; 4 on connector P13.               <ol style="list-style-type: none"> <li>a. Control board output LED, D21 should light. Replace board, if D21 does not come on.</li> <li>b. D21 comes on but no voltage at wheel motor. Move connector from P20 to L1, if motor runs, replace control board.</li> </ol> </li> <li>5. Ohm check wiring going from lever switch to P13 pins 3 &amp; 4. Ohm check wiring from P20 to wheel motor and neutral wire to neutral on control board. Repair or replace as needed.</li> </ol>

## SensorSAFE model troubleshooting guide

Problem	Indicators	Corrective Action
Does not dispense ice.	<ol style="list-style-type: none"> <li>1. Power switch off or faulty.</li> <li>2. Power on but no ice dispensing</li> <li>3. Faulty ice dispense sensor.</li> <li>4. Wheel motor malfunction.</li> <li>5. Defective control board/ daughter card.</li> <li>6. Defective wiring.</li> </ol>	<ol style="list-style-type: none"> <li>1. Turn on or replace the defective switch.</li> <li>2. Verify daughter card is properly aligned and inserted with pins on the control card and bin lid jumper is installed.</li> <li>3. Follow the steps below for ice dispensing.               <ol style="list-style-type: none"> <li>a. If ice and water dispenser, switch connectors going from sensors to daughter and if problem follows to opposite input, replace defective sensor.</li> <li>b. Once switched, if problem stays with same input, jumper pins 3 &amp; 4 on daughter card ice connector and the control board output LED, D19 should light. Replace board, if D19 does not come .</li> </ol> </li> <li>4. Verify 120 vac at motor and replace wheel motor if defective.</li> <li>5. D19 comes on but no voltage at wheel motor. Move connector from P6 to L1, if motor runs, replace control board.</li> <li>6. Ohm check wiring from P6 to wheel motor and neutral wire to neutral on control board. Repair or replace as needed.</li> </ol>
Does not dispense water	<ol style="list-style-type: none"> <li>1. Power switch off/faulty.</li> <li>2. Faulty water dispense sensor.</li> <li>3. Water dispense solenoid malfunction or defective control board/daughter card.</li> <li>4. Defective wiring.</li> </ol>	<ol style="list-style-type: none"> <li>1. Turn on or replace the defective switch.</li> <li>2. Follow the steps below for water dispensing.               <ol style="list-style-type: none"> <li>a. If ice and water dispenser, switch connectors going from sensors to daughter and if problem follows to opposite input, replace defective sensor.</li> <li>b. Once switched, if problem stays with same input, jumper pins 3 &amp; 4 on daughter card water connector and the control board output LED, D21 should light. Replace control board/daughter card, if D21 does not come on. If D21 comes on, move connector from P20 to L1, if solenoid energizes, replace control board.</li> </ol> </li> <li>3. Verify 120 VAC at solenoid and replace if present.</li> <li>4. Ohm check wiring going from water solenoid to P20 terminal on control board. Ohm check wiring from water solenoid neutral wire to neutral on control board. Repair or replace as needed.</li> </ol>
Ice machine runs continuously.	Faulty or incorrectly positioned bin thermostat.	Check for proper positioning. If thermostat does not open when ice is placed on capillary tube, replace bin thermostat.

### Lens/sensor troubleshooting

1. Turn dispenser power switch off and remove splash panel.
2. Disconnect wires from WTR and WM terminals on board.
3. Gently remove sensor/mounting block from splash panel.
4. Inspect lens and sensor, clean if necessary.
5. Restore dispenser power and test sensor by passing hand in front of sensor.
6. If LED on board turns on, sensor is operational. Re-assemble dispenser.
7. If LED does not come on switch sensor leads on board and retest.
8. If opposite LED comes on – replace defective board.
9. If opposite LED does not come on – replace defective sensor.

# Disassembly and replacement instructions

## Dispense wheel removal

1. Remove all ice from storage area of dispenser.
2. Remove center thumbscrew (**Fig. 11.1**), locking plate (**Fig. 17.2**), two wingnuts (**Fig. 11.3**) and backing plate (**Fig. 17.4**) from front of storage hopper (see drawing at right).
3. Remove threaded rod (**Fig. 11.5**), agitator (**Fig. 11.6**), baffle (**Fig. 11.7**), and wheel (**Fig. 11.8**) in this sequence.

## Wheelmotor removal

1. Remove dispense wheel.
2. Remove four (4) dispenser motor bracket mounting screws and washers (**Fig. 12.1**).
3. Remove (4) screws holding motor to mounting bracket (**Fig. 12.2**).

Fig. 11

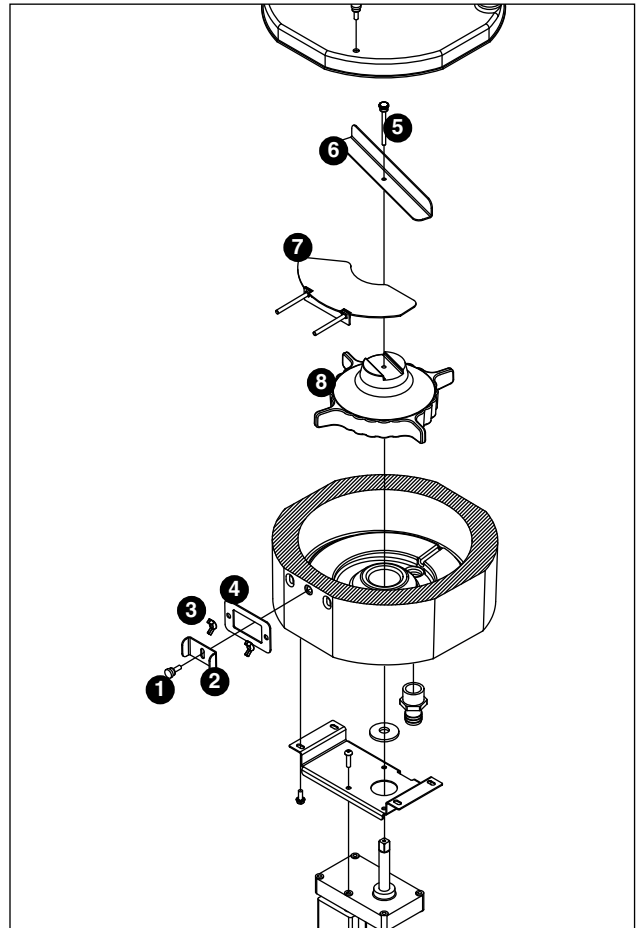
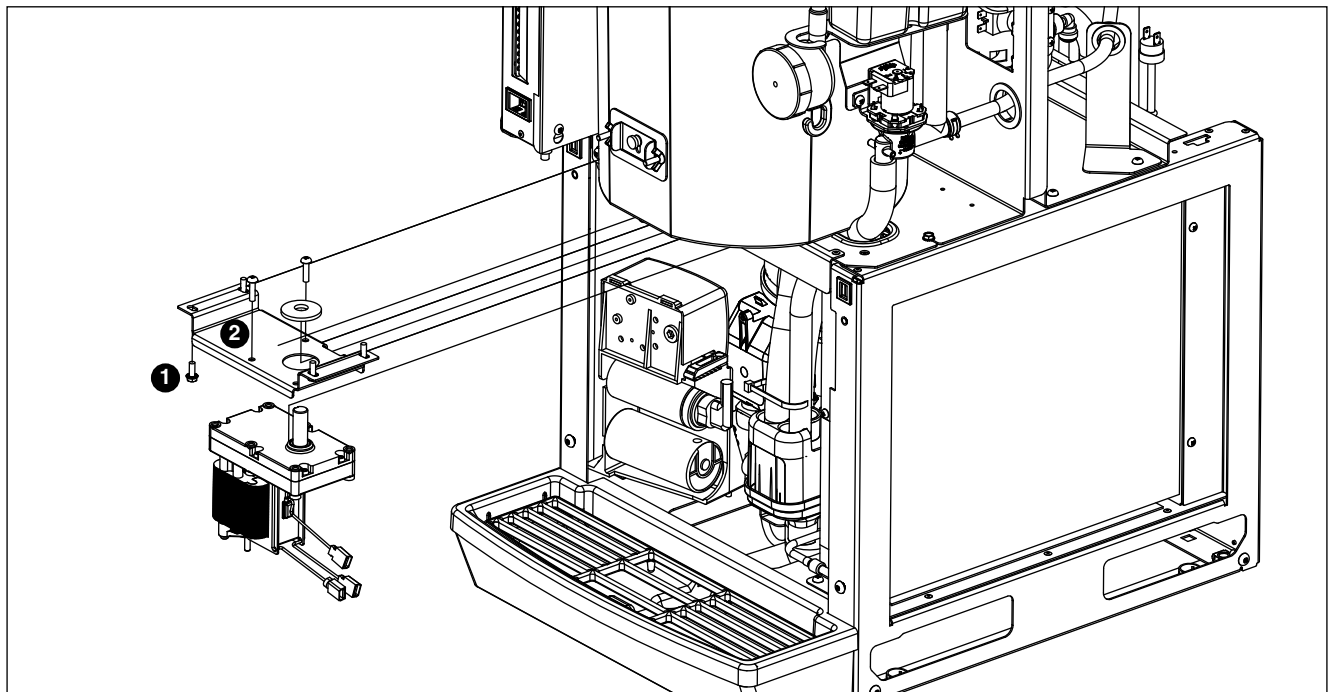


Fig. 12

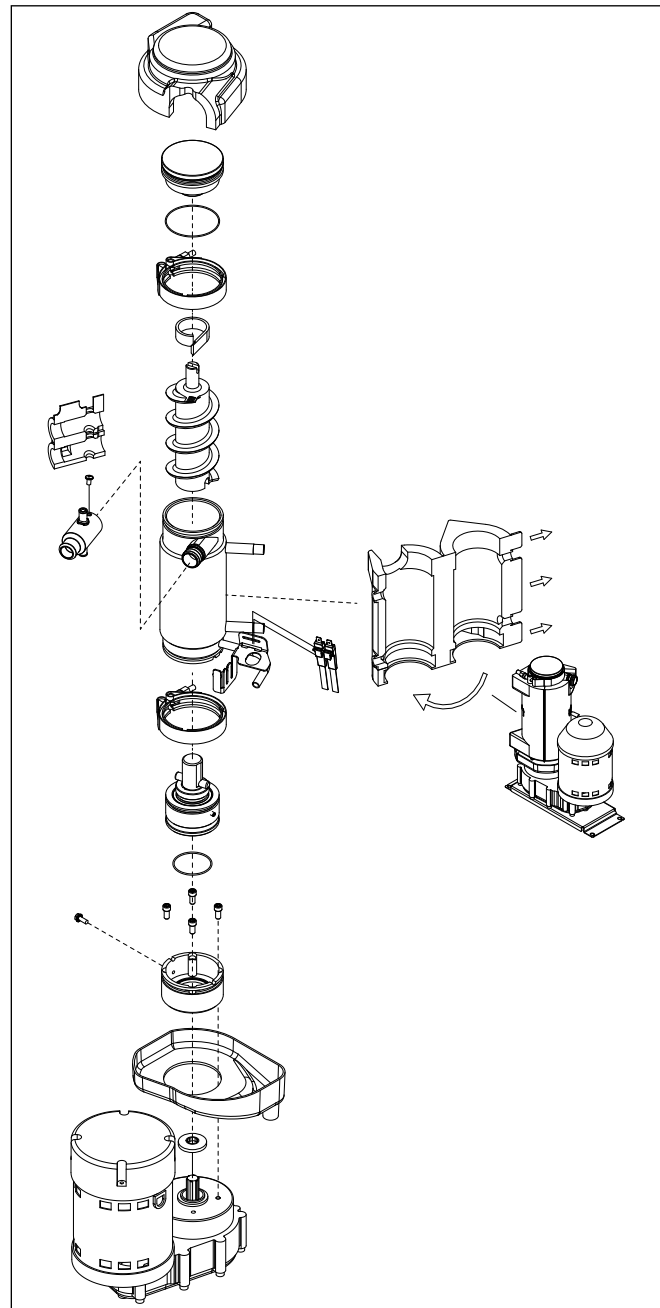


## Evaporator disassembly

**Note:** The upper bearing, lower bearing and auger assemblies must be replaced as assemblies. The bottom and top bearing assemblies cannot be field assembled to factory specifications.

1. Press **CLEAN** switch.
2. Wait for **LOW WATER** light to illuminate.
3. Turn OFF power.
4. Remove top bearing insulation.
5. Remove compression nozzle insulation.
6. Disconnect vent and drain tube from nozzle.
7. Disconnect compression nozzle from evaporator.
8. Disconnect evaporator water feed line.
9. Remove nut and upper vee band coupling from top of evaporator.
10. Lift top bearing assembly straight up with a slight rotating motion and remove.
11. Remove ice compression loop located at top of auger.
12. Lift auger straight up and out of evaporator.
13. Remove nut and lower vee band coupling from bottom of evaporator.
14. Lift evaporator to clear bottom bearing assembly.
15. Loosen hex head bolt in side of mounting base with 5/16 wrench and lift lower bearing assembly.
16. Remove condensate shield.
17. Remove 4 Allen head machine screws holding mounting base to gearbox.

Fig. 13





## Evaporator reassembly

1. Clean gearmotor boss, output shaft and shaft well.
2. Install drain pan and evaporator mounting base.
3. Fill gearmotor shaft well with food grade grease (**Fig. 14**).
4. Install condensate shield and seat against gearmotor boss.
5. Install bearing O ring in groove in evaporator mounting base.
6. *While maintaining firm downward pressure on bottom bearing assembly*, tighten hex head bolt with a 5/16 wrench.
7. Position evaporator over lower bearing assembly and align grooves with pins in bearing assembly.
8. Install vee band clamp and nut to 70 in/lb. (**Fig. 15**).  
**Note:** Clamp **must be oriented as shown** in order for the insulation to be placed properly.
9. Place auger in center of evaporator and rotate to mate with drive pin.
10. Install ice compression loop, orienting loop.
11. Install upper bearing and seal assembly, rotating bearing to slip pin into auger slot.
12. Install upper vee band clamp and nut to 70 in/lb.
13. Install compression nozzle and tubing.
14. Secure ice transport tube with clamp (**Fig. 16.1**).  
**Note:** Clamp **must be oriented as shown** in order for the insulation to be placed properly.
15. Install compression nozzle insulation (**Fig. 16.2**).
16. Install vent and drain tube (**Fig. 16.3**).
17. Install top bearing insulation (**Fig. 16.4**).

## Gearmotor replacement

1. Disassemble evaporator.
2. Disconnect the wire connectors.
3. Remove 4 screws holding gearmotor mounting plate to base of ice machine and lift gearbox and motor clear of ice machine.
4. Remove machine screws holding mounting plate to motor.
5. Install new motor in reverse order.

Fig. 14

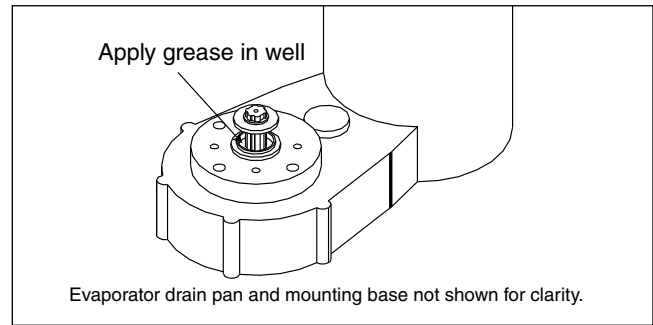


Fig. 15

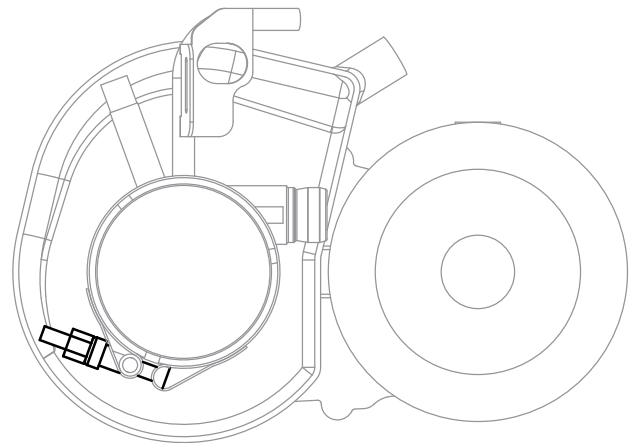
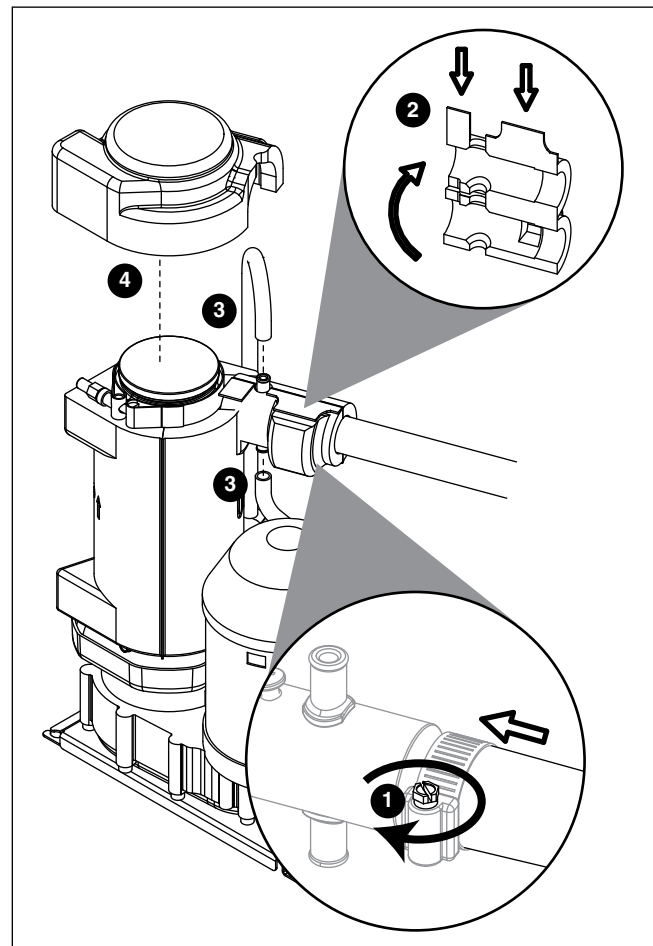


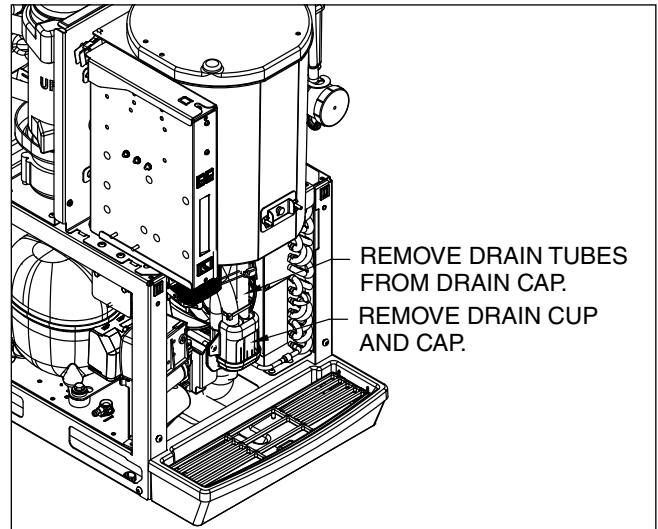
Fig. 16



## Fan removal

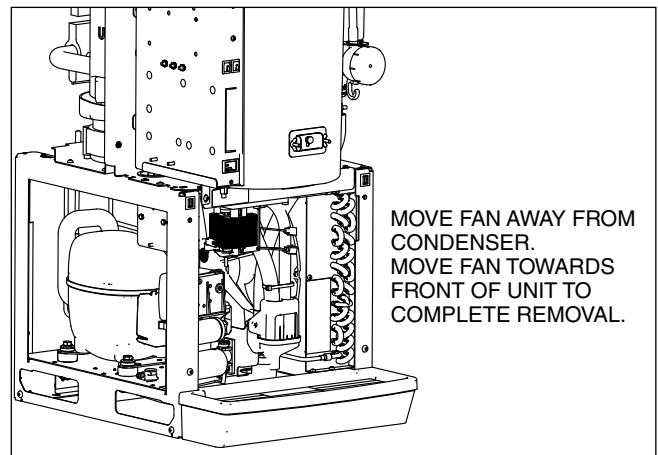
1. Remove 6 fan mounting screws and 3 drain tubes from bracket.

**Fig. 17**

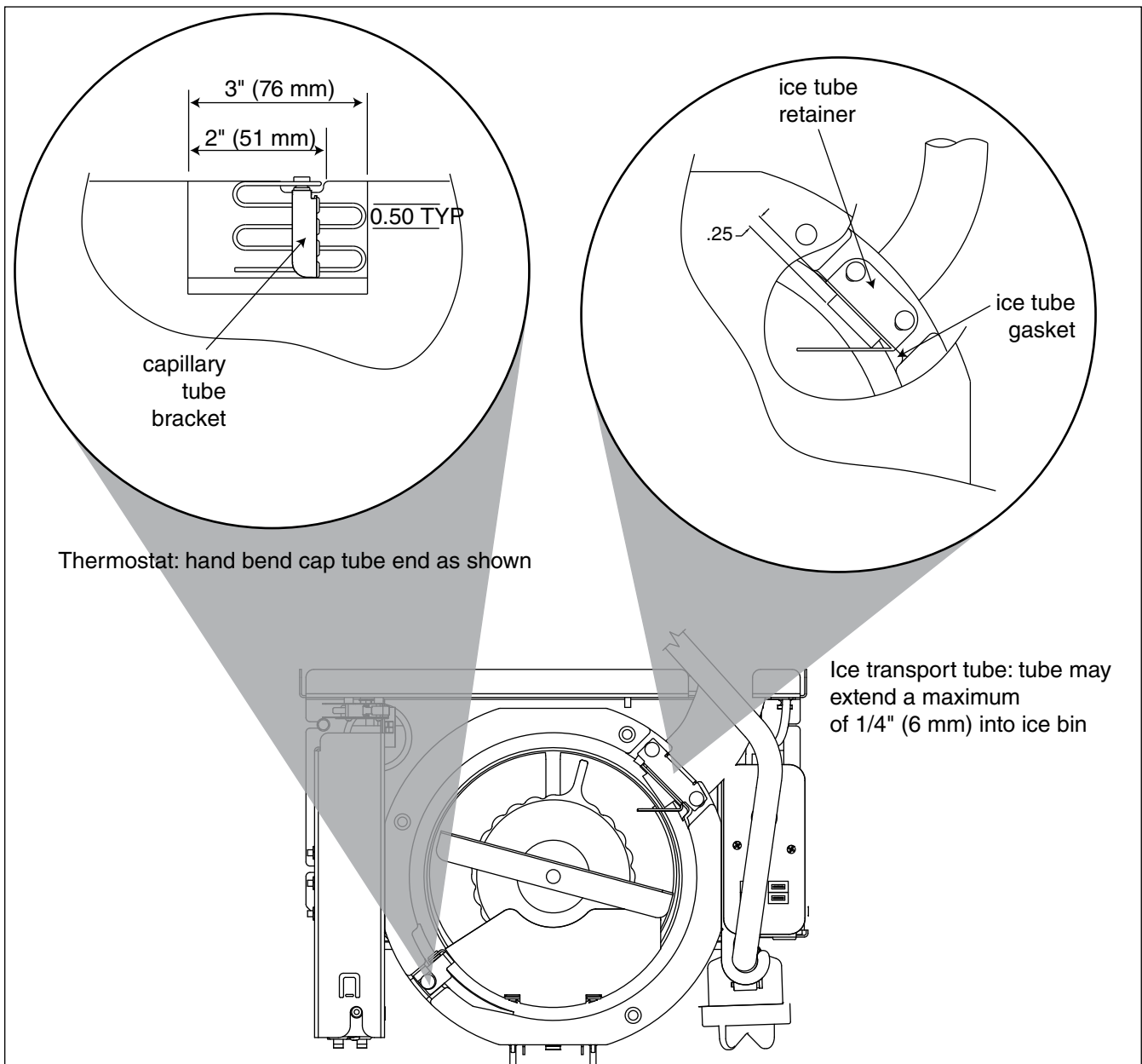


2. Rotate fan mounting bracket toward back of unit and pull fan assembly toward front of unit.

**Fig. 18**



## Thermostat and ice transport tube replacement

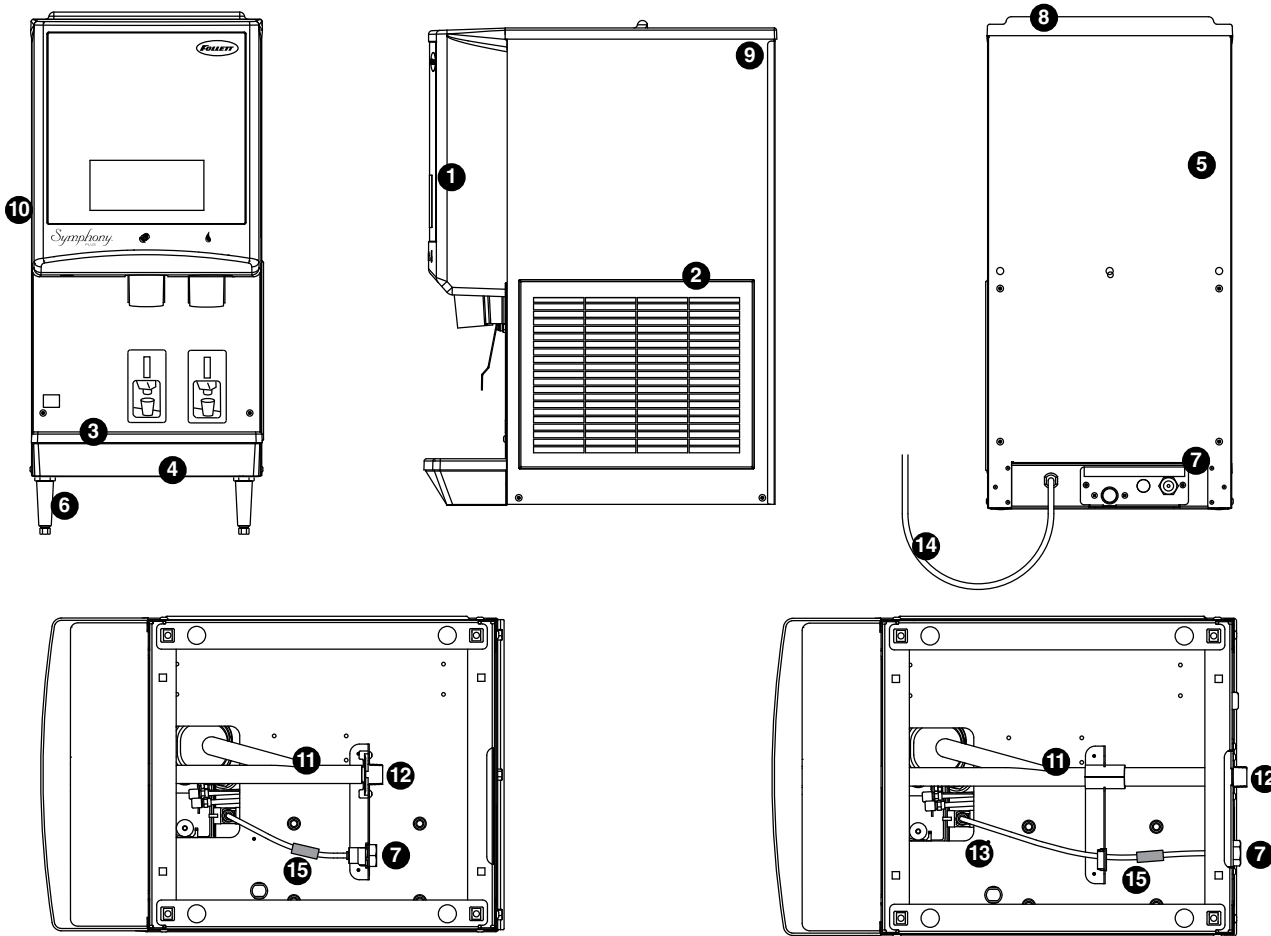


### Ice transport tube replacement

1. Refer to Fig. 16..

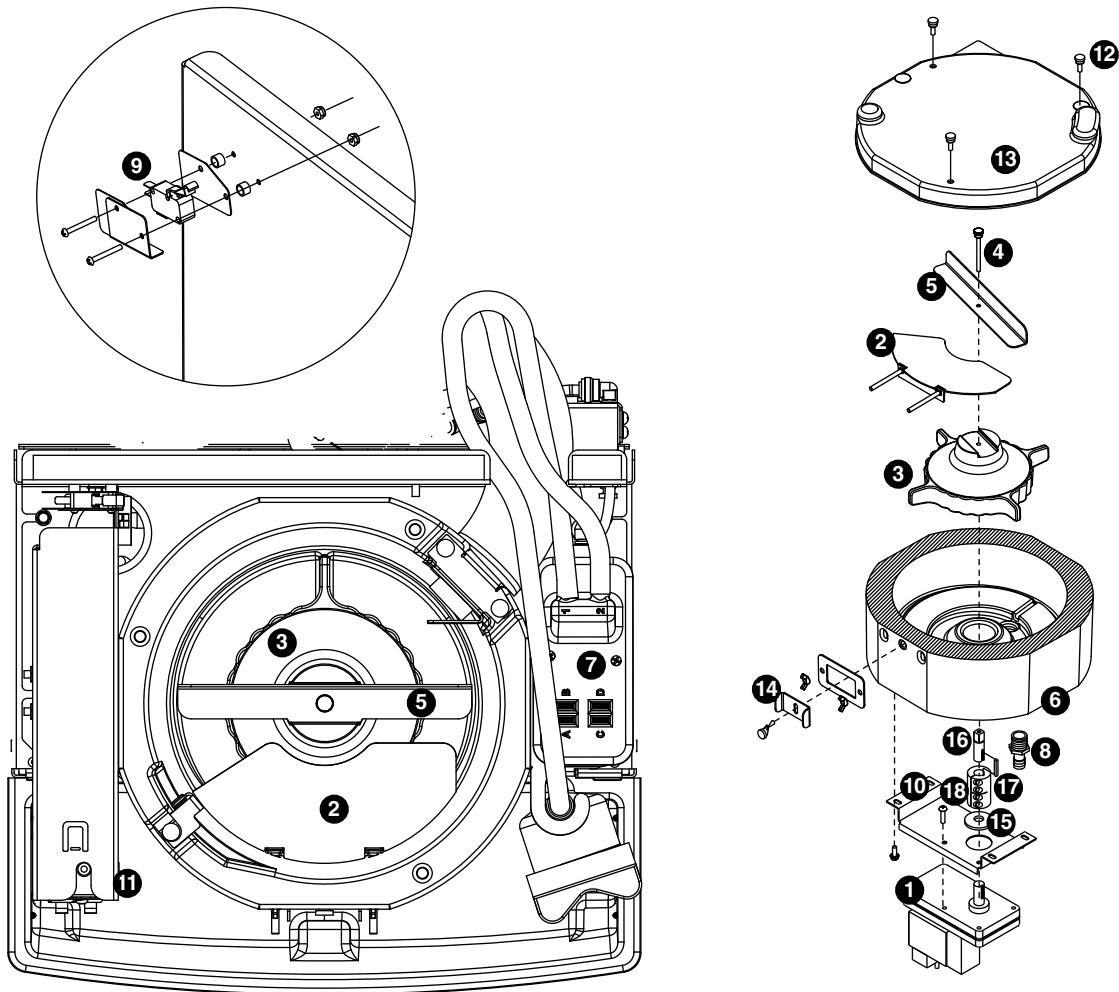
# Replacement parts

## Dispenser exterior



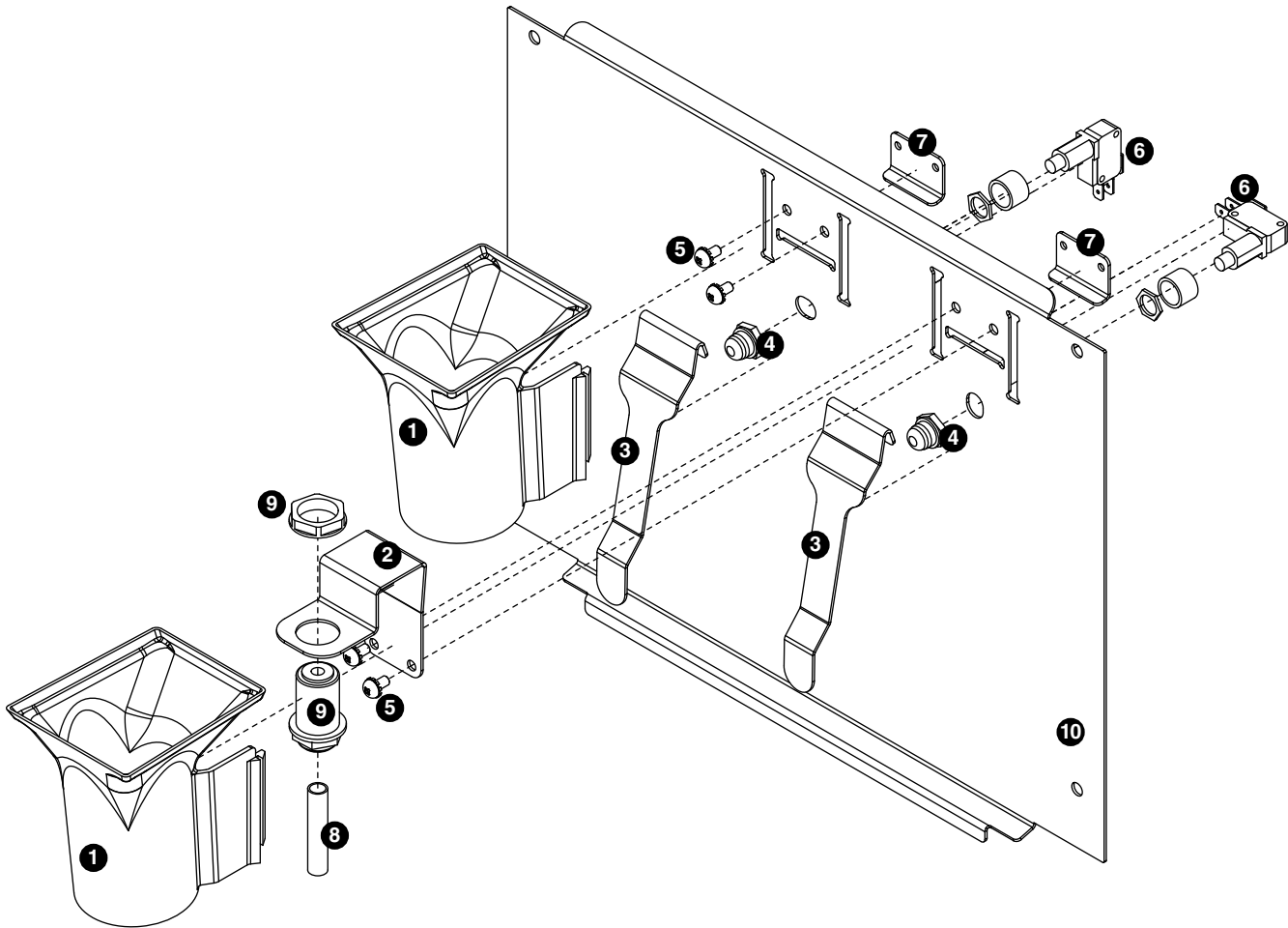
Reference #	Description	Part #
1	Cover, front, ice and water	01064575
Not shown	Cover, front, ice only	01064583
2	Louver, intake, plastic	00967117
Not shown	Grille, drain pan, gray plastic	01051614
3	Drain pan, plastic	00967059
4	Drain pan assembly (includes hardware, pan and grille)	502410
5	Panel, rear	01220904
6	Leg kit, 4" (10.2 cm), adjustable – set of 4	502399
7	Fitting, water inlet, brass 3/8" FPT x 1/4" john guest	01035021
8	Lid, top panel, plastic	00967091
9	Panel, right side	01220888
10	Panel, left side	01220896
11	Tube, drain pan and cup, includes drain cup	01065390
12	Fitting, drain	209042
13	Valve, 1/4" john guest	01035526
14	Cord, power	01111681
15	Valve, check, 1/4"	01122381
Not shown	Bracket, wall 16" (40.6 cm)	502873
Not shown	Clip, valve	01035534
Not shown	Grille, drain pan - case of 12	01071224

## Wheelmotor and drive system



Reference #	Description	Part #
1	Motor, wheel, short shaft (includes gear motor shield)	PD502933
2	Baffle, ice (securing hardware, part# 00167973, included)	502414
3	Wheel with Agion, agitator	502387
4	Rod, threaded (includes knurled nut)	502390
5	Agitator, rotating	502386
See page 35	Bracket, capillary tube	502406
See page 35	Retainer, ice tube	00977314
Not shown	Gasket, ice tube	01148782
6	Assembly, hopper with Agion (includes drain fitting)	502413
7	Reservoir body (includes fasteners)	01230622
8	Fitting, hopper drain, 3/4 MPT, 3/4" barb fitting	207095
9	Switch, interlock	502416
10	Support plate, motor	502423
11	Cover, electrical box	502408
12	Screws, 10-32 x 1/2 (6 needed)	201022
13	Hopper lid with hopper lid safety switch actuation	00135962
14	Hardware, baffle securing	00167973
15	Shield, gear motor	502537
16	Drive shaft extension	502384
17	Key, 1/8" sq x 1-1/4 lg	501273
18	Coupling (includes key) (short shaft motor only)	502385
Not shown	Gasket, reservoir	01148766

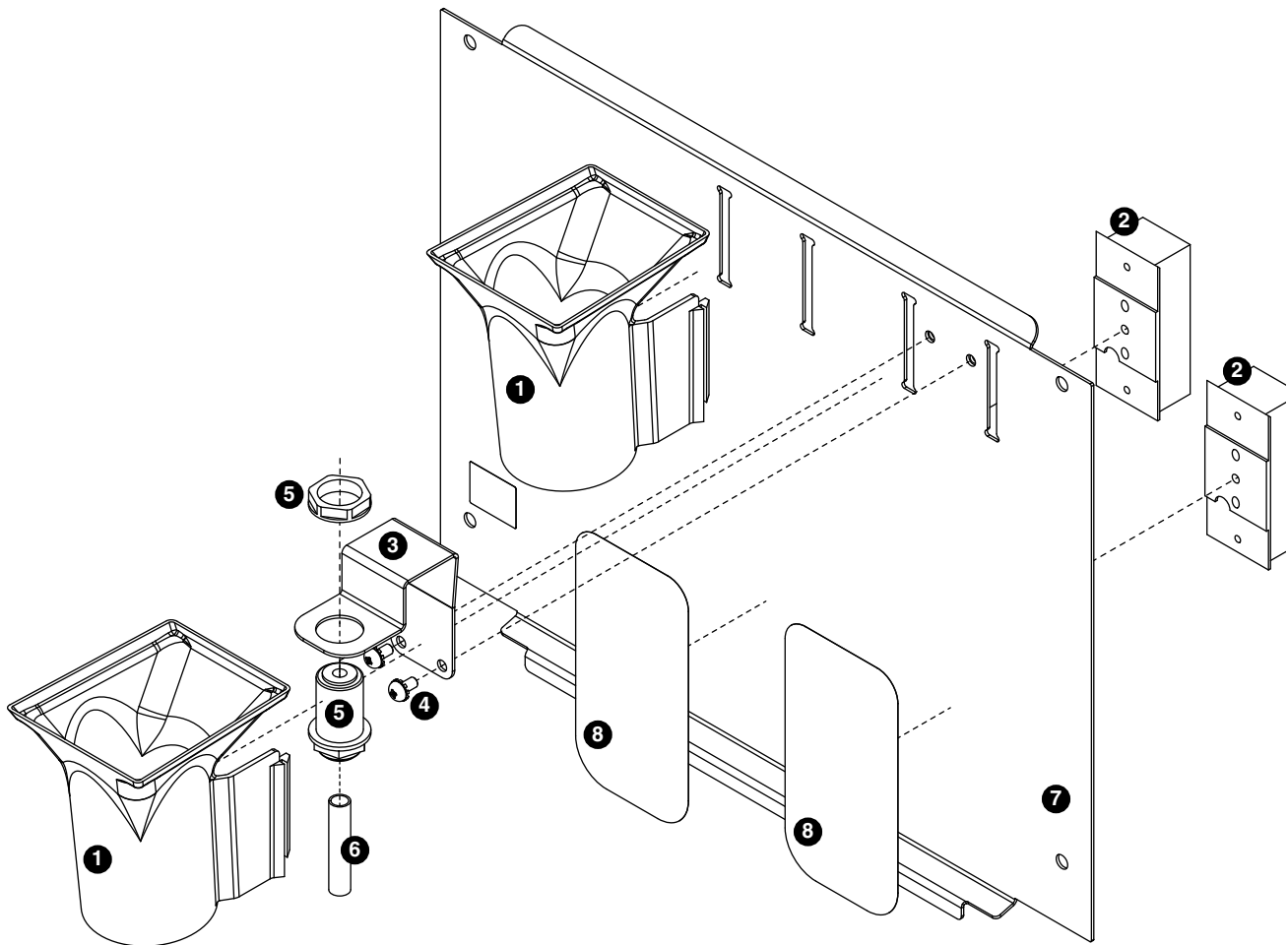
## Dispense chute and splash panel (models with lever dispensing)



Reference #	Description	Part #
1	Chute, ice or water (with Agion® antimicrobial product protection <sup>1</sup> )	00967760
2	Support, water tube	00960682
3	Lever	00976845
4	Boot, dispense switch button	502418
5	Screw, panel	00982421
6	Switch, dispense	01562230
7	Bracket, lever support	00958793
8	Tube, water solenoid	502420
9	Fitting, bulkhead (with nut)	00976787
Not shown	Splash panel (ice only)	01161256
10	Splash panel	00969980

<sup>1</sup> Disclaimer: Antimicrobial protection is limited to the treated components and does not treat water or ice. Agion is a registered trademark of Sciessent LLC.

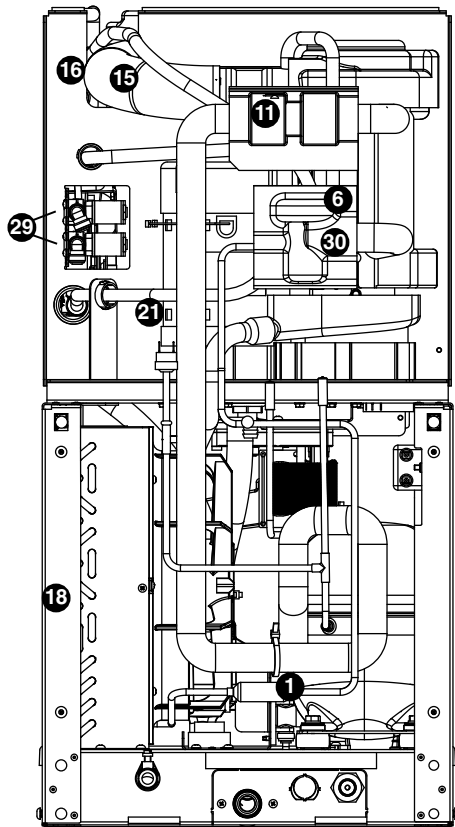
## Dispense chute and splash panel (models with SensorSAFE infrared dispensing)



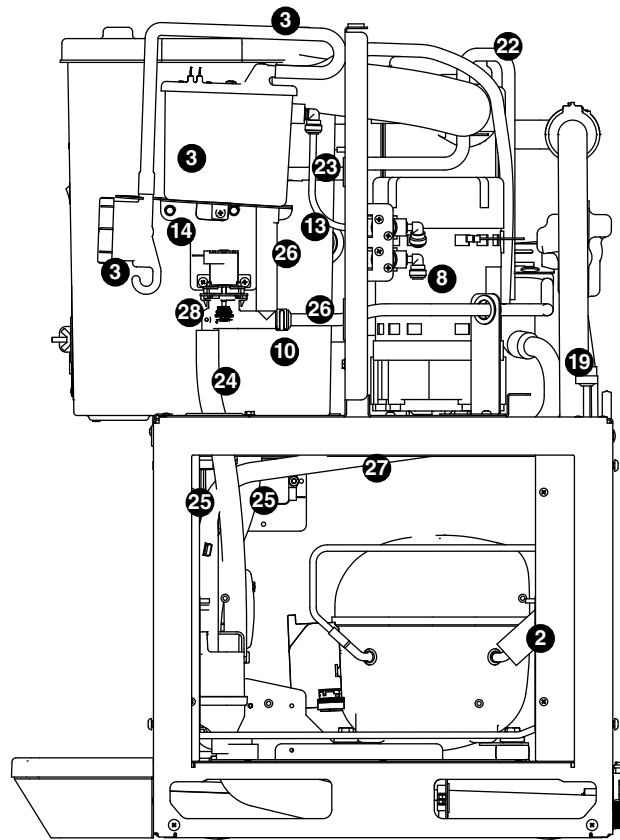
Reference #	Description	Part #
1	Chute, ice or water (with Agion)	00967760
2	Sensor (includes lens and Ty-rap*)	00122978
3	Support, water tube	00960682
4	Screw, panel	00982421
5	Fitting, bulkhead (with nut)	00976787
6	Tube, water solenoid	502420
7	Splash panel	01161264
8	Lens, sensor (each)	502690
Not shown	Splash panel, ice only	01161272

\* Ty-rap is a registered trademark of Thomas & Betts International, Inc.

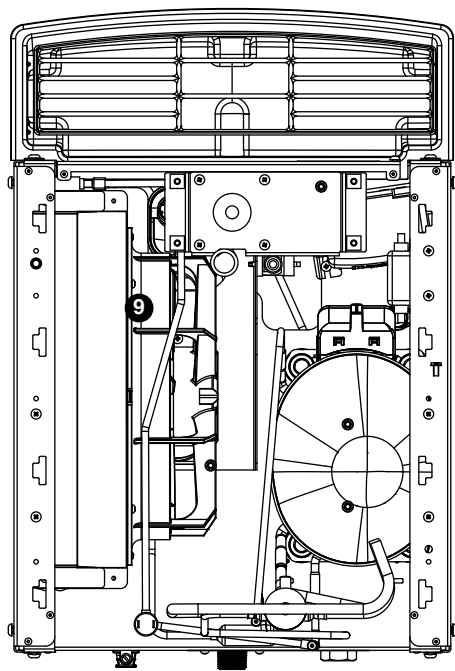
# Ice machine components



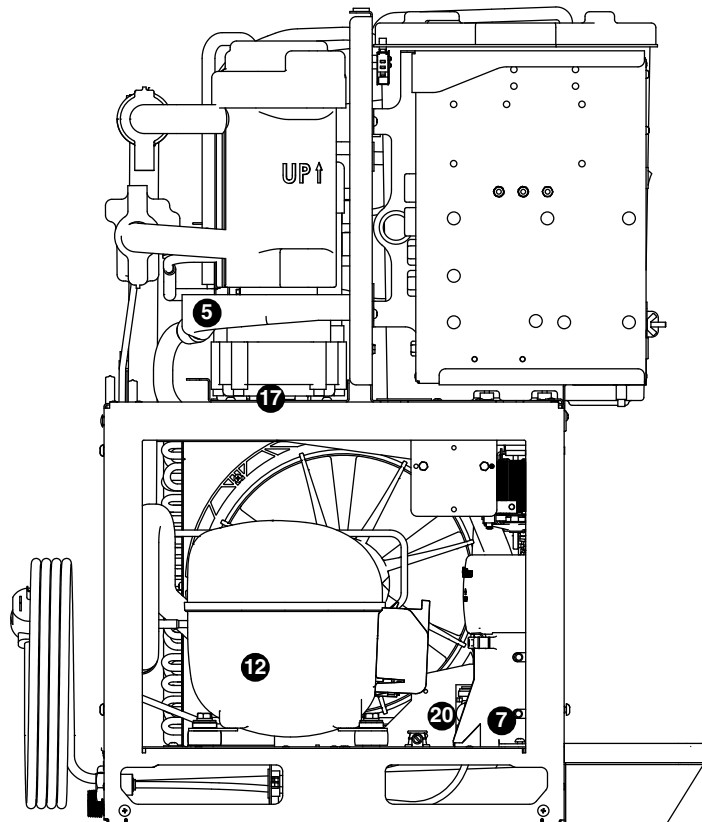
Rear view



Right side view



Top view (lower section)

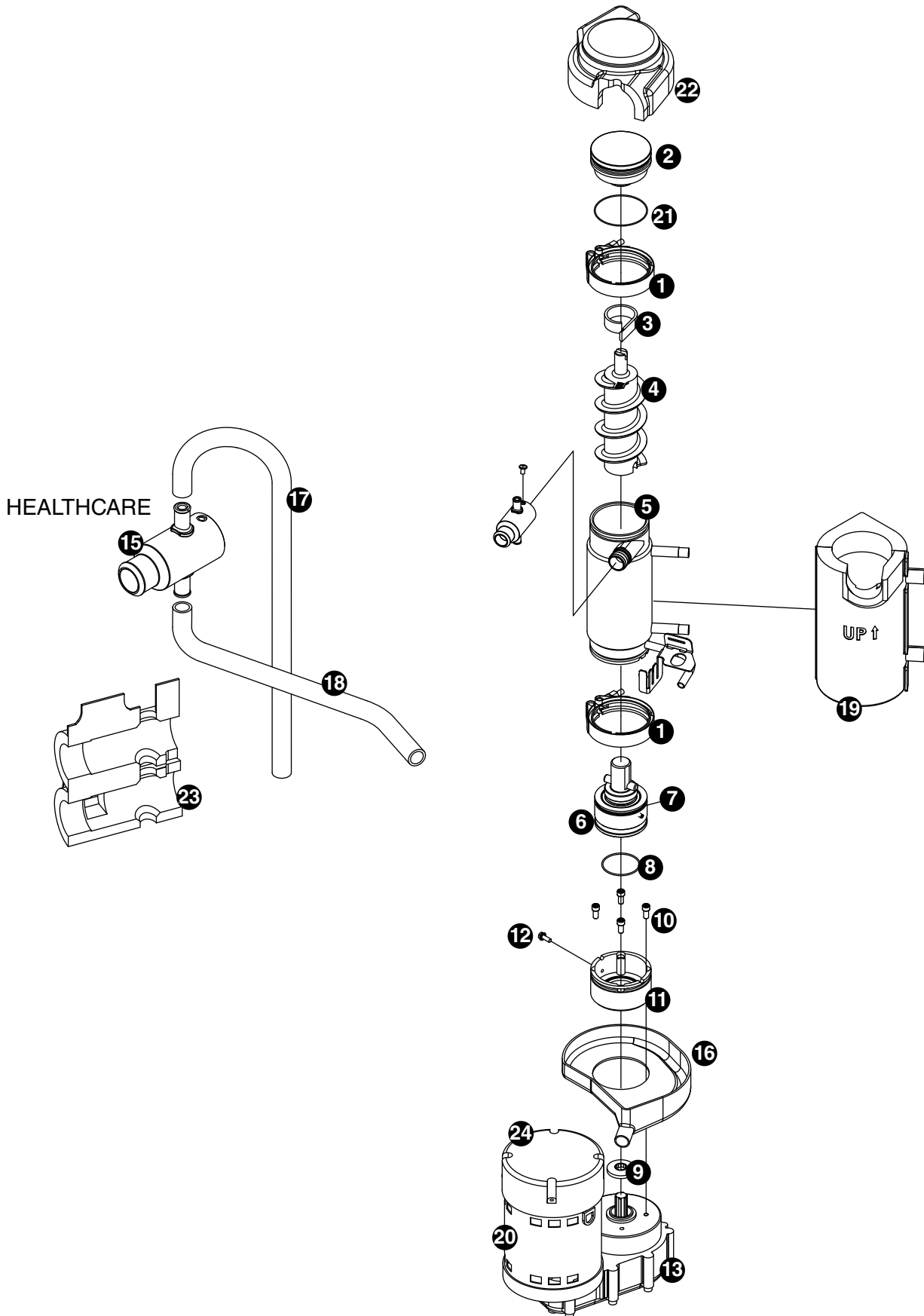


Left side view



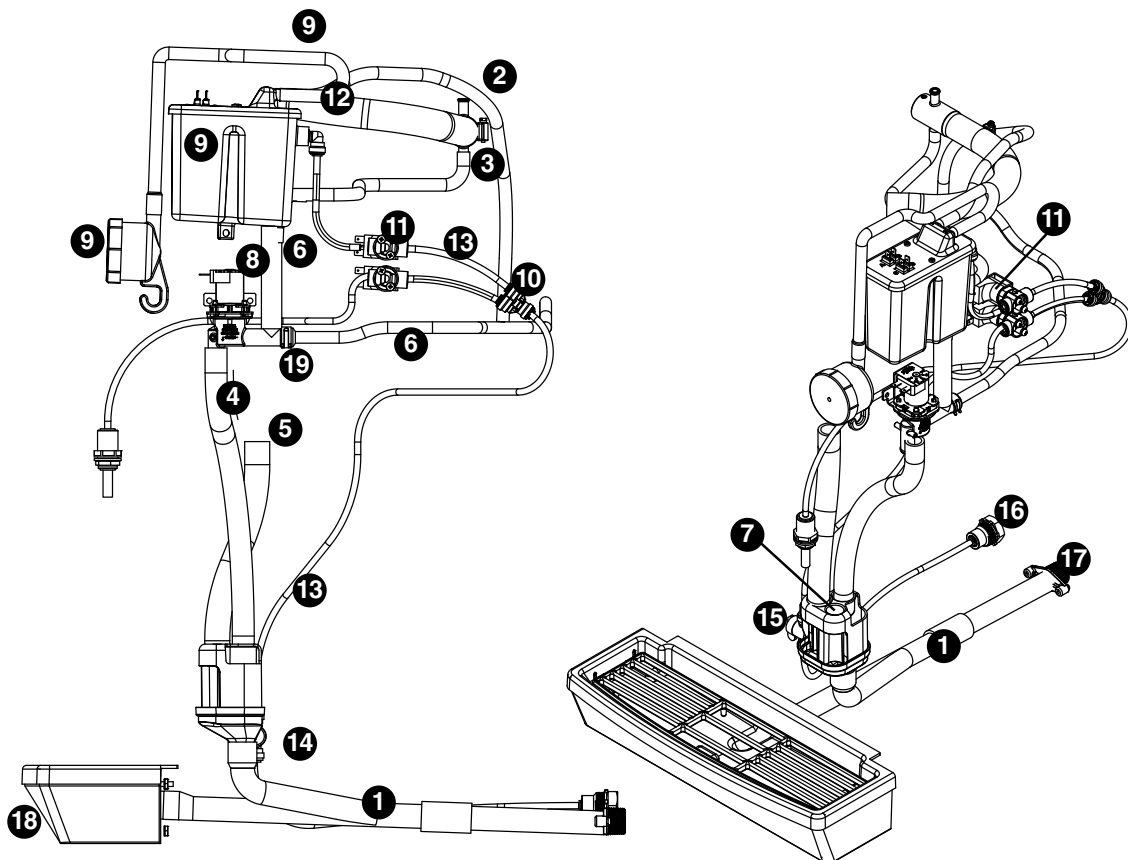
Reference #	Description	Part #
1	Drier	01468750
2	Coil, condenser (includes shroud)	01468776
3	Reservoir (includes lid, gasket, fasteners, clean and vent tubing, cleaning cup)	01230630
Not shown	Gasket, reservoir	00989988
4	Evaporator (see page 48 for detailed drawing)	—
5	Drain pan, evaporator	208190
6	Valve, expansion, thermal	01468768
7	Valve, shut-off, water, plastic, 1/4"	01035526
8	Gearbox & motor, 230 V, 50 Hz (includes 307192)	502832
9	Fan blade, bracket and motor 230 V, 50 Hz	01325745
10	Clamp, hose	01281450
11	Insulation, TEV bulb	00106534
Not shown	Overload, compressor, 230 V	01087188
12	Compressor, 230 V, 50 Hz	01468792
13	Tubing, polypropylene, reservoir supply (sold by the foot)	502079
14	Bracket, reservoir	01191196
15	Tube, ice transport (13") and insulation	01542935
16	Insulation, ice tube, 12" (30.5 cm) required	204360
17	Mounting base, gearmotor	01179761
18	Cord, power	01111681
19	Hi-pressure cut-out	00117077
20	Clip, water shut-off valve	01035534
21	Fitting, flow divider, 1/4" tubing (After serial number L78614)	01035526
Not shown	Gasket, ice hose	01139781
22	Tubing, nozzle vent	01133339
23	Tubing, nozzle drain	01133370
24	Tubing, purge	01054790
25	Tubing, bin	01054782
26	Tube, fill/purge - reservoir-solenoid-evaporator feed (includes hose clamp)	01261536
27	Tubing, evaporator drain pan	01054154
28	Solenoid, purge	01231448
29	Solenoid, fill, dispense	01398981
30	Insulation, TEV	01165604
Not shown	Tubing, reservoir vent, per foot (21.5" required)	01165372
Not shown	Fan shroud	01404607

# Evaporator replacement parts



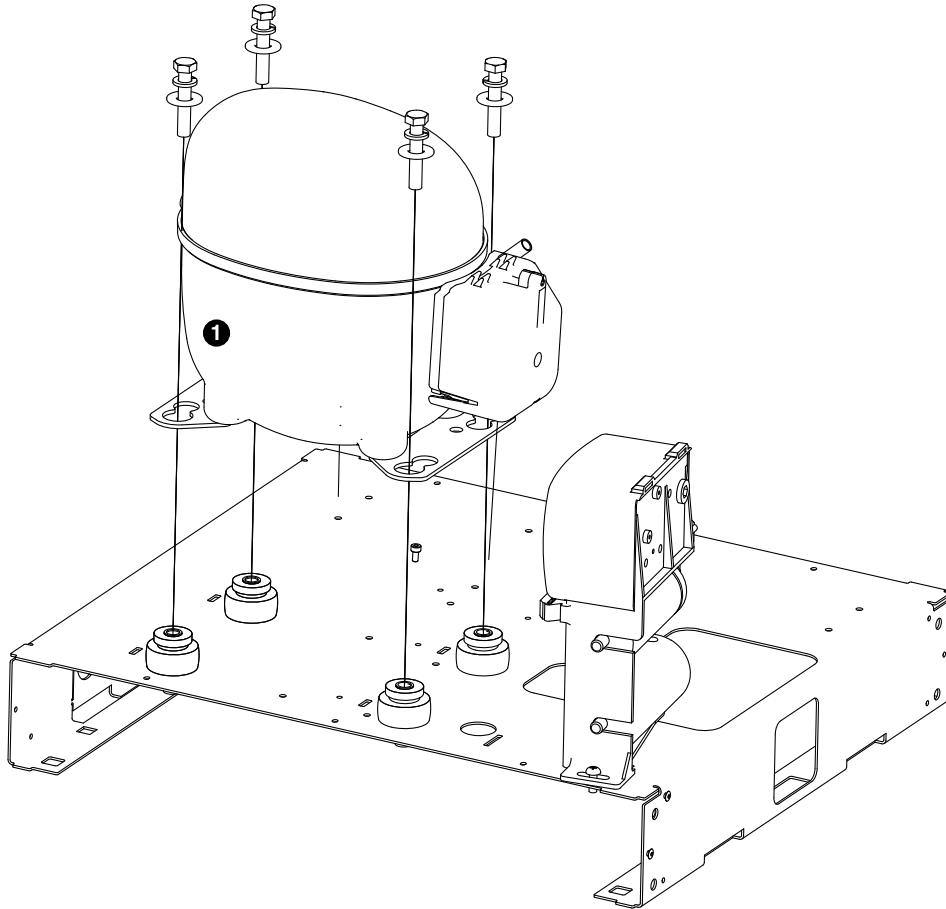
Reference #	Description	Part #
1	Coupling, vee band, includes nut	502735
2	Bearing assembly, top	502736
3	Loop, ice compression, beveled	502110
4	Auger (see below for Flaker-specific components)	502737
5	Evaporator (includes insulation jacket, and top bearing insulation)	01064658
6	Bearing assembly, bottom (includes O rings and condensate shield)	502738
7	O ring, bearing housing	500496
8	O ring, mounting base	501063
9	Shield, condensate	500744
10	Screw, Allen 1/4 20 x 1/2 (set of 4)	501080
11	Mounting base, evap. (includes 501063)	502733
12	Bolt, mounting base	502227
13	Gearbox & motor (includes mounting base) 230 V 50 Hz	502832
Not shown	Mounting base, gearmotor	01072891
15	Compression nozzle, with single drain	01064674
16	Drain pan, evaporator	502727
17	Tube, compression nozzle vent	01148691
18	Tube, compression nozzle, single drain	01148790
Not shown	Grease, Mobil FM222, 14 oz	501111
19	Insulation jacket, evaporator	01049592
20	Capacitor, gearmotor, 230 V	01543537
21	O ring, top bearing	01064963
22	Insulation, top bearing	01049600
23	Insulation, compression nozzle, single drain	01049584
24	Cover, aluminum	01106376

## Water supply and drains



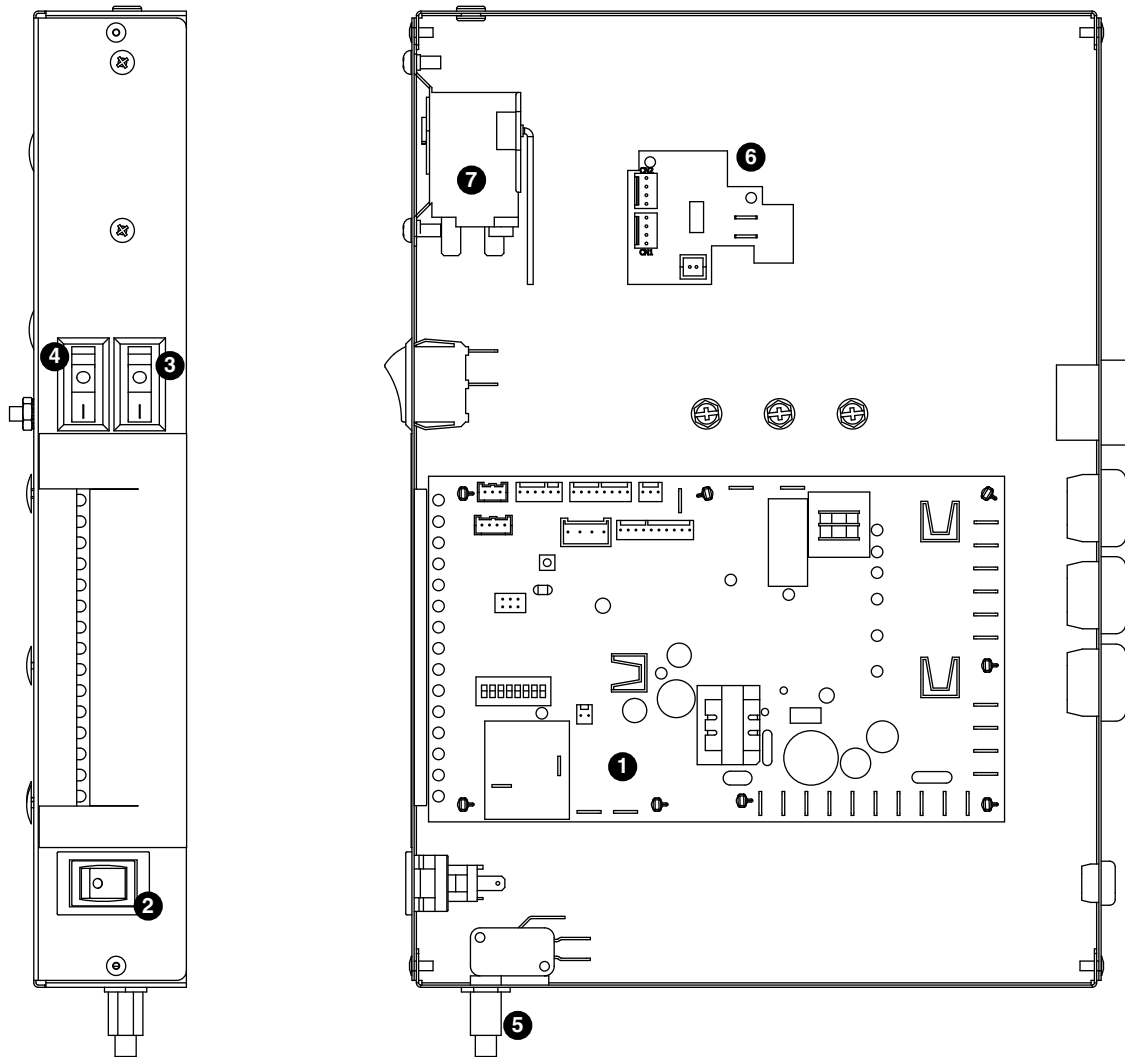
Reference #	Description	Part #
1	Tube, drain pan and cup, includes drain cup	01065390
2	Tube, nozzle vent	01148691
3	Tube, nozzle drain	01148790
4	Tube, purge	01054790
5	Tube, bin	01054782
6	Tube, fill/purge - reservoir-solenoid-evaporator feed (includes hose clamp)	01261536
7	Tube, evaporator drain pan	01054154
8	Solenoid, purge	01231448
9	Reservoir (includes lid, gasket, fasteners, clean and vent tubing, cleaning cup)	01230622
10	Fitting, flow divider, 1/4" tubing (After serial number L78614)	01352491
11	Solenoid, fill, dispense (2)	01398981
12	Fitting, 1/4" stem x 1/4" push-in	00121699
13	Tubing, 1/4"	502079
14	Clip, 1/4" valve	01035534
15	Valve, 1/4"	01035526
16	Fitting, 3/8" FPT x 1/4" push-in	01065275
17	Fitting, 3/4" MPT x 3/4" barb	00109728
18	Drain pan	00967059
Not shown	Bracket, drain cup	01051945
Not shown	Valve, check, 1/4"	01122381
19	Clamp, hose	01281450

## Compressor - 230 V 50 Hz



Reference #	Description	Part #
1	Compressor, 230 V (includes start cap, run cap, and start relay)	01468792
Not shown	Capacitor and end cap, compressor overload, run capacitor, and start relay	01471606

## Electrical components



Reference #	Description	Part #
1	Board, control circuit, 230 V, 50 Hz	01111657
2	Switch, clean	01229418
3	Switch, rocker, power	502209
4	Switch, rocker, bin signal	502209
5	Switch, cleaning, SensorSAFE models	502409
6	Daughter card, SensorSAFE models	01544238
7	Bin thermostat	500514

## Water treatment accessories for Symphony Plus ice and water dispensers

Reference #	Description	Part #
<b>Standard capacity filter system</b>		
Not shown	Follett QC4-FL4S water filter system (includes FL4S primary cartridge and head, coarse pre-filter and head, pressure gauge, flushing valve; assembled and installed on mounting bracket), one per ice machine	00130229
Not shown	Follett FL4S primary replacement cartridge	00130245
Not shown	Water filter cartridge – primary, carton of 6	00954297
Not shown	Everpure coarse pre-filter cartridge	00130211
Not shown	Water pre-filter cartridge – pre-filter, carton of 12	00954305
<b>High capacity filter system</b>		
Not shown	High capacity water filter system (one per ice machine)	00978957
Not shown	High capacity water filter cartridge – primary, single	00978965
Not shown	High capacity water filter cartridge – primary, carton of 6	00978973
Not shown	Water pre-filter cartridge – pre-filter, single	00130211
Not shown	Water pre-filter cartridge – pre-filter, carton of 12	00954305
<b>Carbonless high capacity filter system</b>		
Not shown	Carbonless high capacity water filter system (one per ice machine) – Horizon™ and MaestroPlus series ice machines	01050442
Not shown	Carbonless high capacity water filter cartridge – primary, single	01050426
Not shown	Carbonless high capacity water filter cartridge – primary, carton of 6	01050434
Not shown	Water pre-filter cartridge – pre-filter, single	00130211
Not shown	Water pre-filter cartridge – pre-filter, carton of 12	00954305
<b>Other filtration</b>		
Not shown	Claris hardness removal filtration system	00986059
Not shown	Replacement filter for Claris system	00985127
Not shown	Reverse osmosis system, 200 gallons per day	00986034
Not shown	Replacement reverse osmosis cartridge	00985085
Not shown	Replacement reverse osmosis pre-filter	00985077
Not shown	Cleaning plug for reverse osmosis system	00985119
Not shown	Cleaning cartridge for reverse osmosis system	00985101
<b>Water pressure</b>		
Not shown	Water pressure regulator (25 psi)	501781
<b>Cleaning</b>		
Not shown	SafeClean Plus, case of 6	01149954
Not shown	SafeClean Plus, case of 24	01149962
Not shown	Sponge, sanitary, each	00131524

## Warranty Registration and Equipment Evaluation

Thank you for purchasing Follett® equipment. Our goal is to deliver high value products and services that earn your complete satisfaction by delivering high-value products and services backed by outstanding customer and technical support.

Please review the installation instructions thoroughly. It is important that the installation be performed to factory specifications so your equipment operates at its maximum efficiency.

Follett LLC will not be liable for any consequential damages, expenses, connecting or disconnecting charges, or any losses resulting from a defect of the machine. For full warranty details, visit our website [www.follettice.com/productwarranties](http://www.follettice.com/productwarranties).

Registering your equipments helps Follett track your equipment's service history should you need to contact us for technical support, and your feedback helps us improve our products and services. Please visit [www.follettice.com/support](http://www.follettice.com/support) to complete the Warranty Registration form.

Should you have any questions, please contact Follett's technical support group at (877) 612-5086 or (610) 252-7301 and we will be happy to assist you.

Calgon is a licensed trademark distributed by Nu-Calgon, in the United States.

Dow Corning is a registered trademark of Dow Corning Corporation in the United States and other countries.

SafeCLEAN, SaniSponge, SensorSAFE, and Symphony Plus are trademarks of Follett Products, LLC.

Follett is a registered trademarks of Follett Products, LLC, registered in US.



801 Church Lane • Easton, PA 18040, USA  
Toll free (877) 612-5086 • +1 (610) 252-7301  
[www.follettice.com](http://www.follettice.com)

Follett Europe Polska Sp. z o.o.  
Mokry Dwór 26 c • 83-021 Wiślina, Poland  
+48 (58) 785-6140 • Fax +48 (58) 785-6159  
[www.folletteurope.com](http://www.folletteurope.com)

01540772R04

© Follett Products, LLC 9/24