

# Horizon Elite™ Ice Machine Installation Instructions for Ice Storage Bin Top-mount Applications

D1010R, D1410R, D1412R, D1810R, D2110R

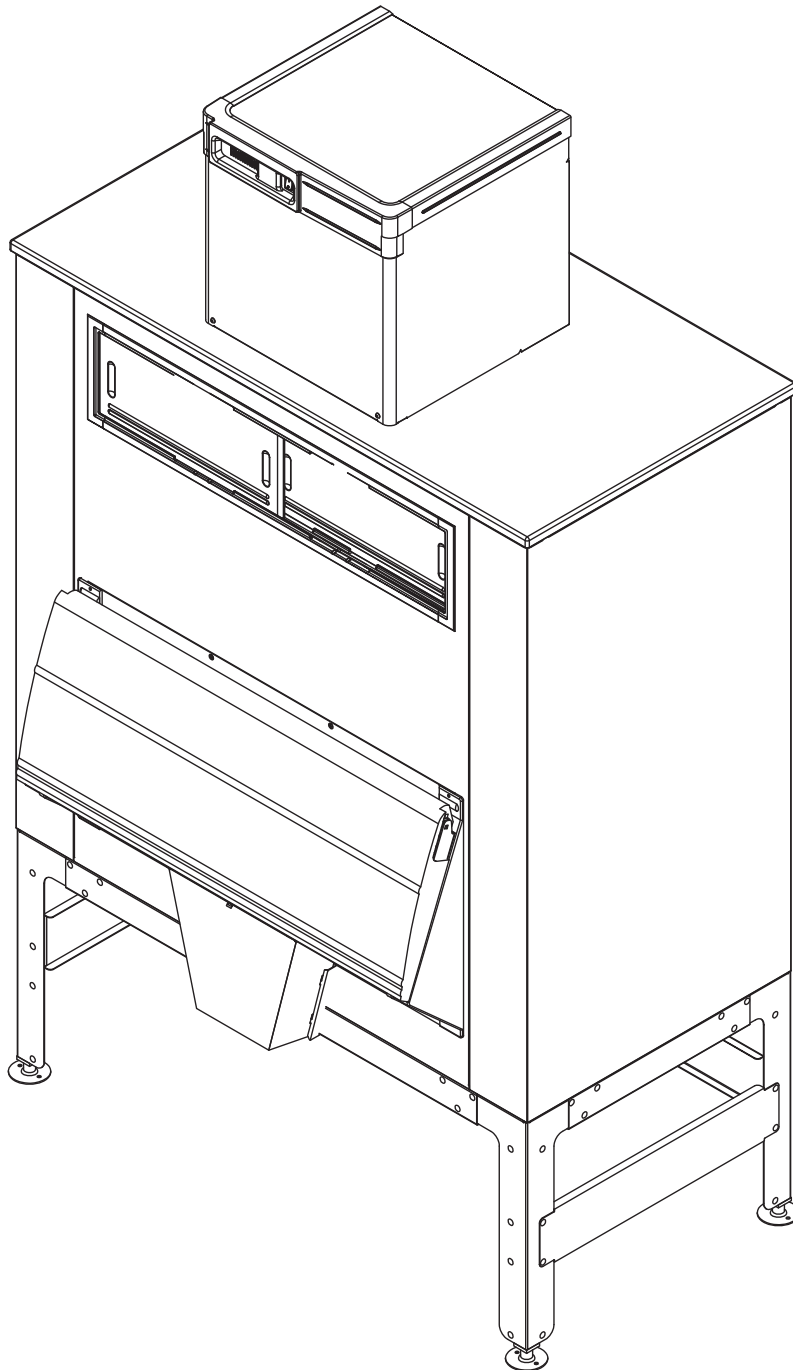
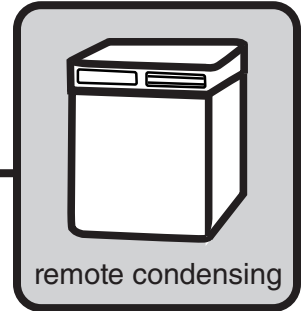

801 Church Lane • Easton, PA 18040, USA  
Toll free (877) 612-5086 • +1 (610) 252-7301  
[www.follettice.com](http://www.follettice.com)

01565068R00

 **CAUTION!**

- This appliance should be connected by a qualified person in accordance with applicable codes.
- If the supply cord is damaged, it must be replaced by the manufacturer, its service agent or similarly qualified persons in order to avoid a hazard.
- Connect to potable water supply only.
- This appliance can be used by children aged 8 years and above and persons with reduced physical, sensory, or mental capabilities, or lack of experience and knowledge if they have been given supervision or instruction concerning use of the appliance in a safe way and understand the hazards involved. Children should be supervised to ensure that they do not play with the appliance.
- This appliance is intended to be used for household and similar applications such as staff kitchen areas in shops, offices and other working environments; farm houses and by clients in hotels, motels and other residential type environments; bed and breakfast type environments; catering and similar non-retail applications.
- **WARNING!** To avoid a hazard due to instability of the appliance, it must be fixed in accordance with the instructions.

Read and complete the following 8 installation steps

1 **Unpack** \_\_\_\_\_



2 **Site preparation** \_\_\_\_\_



3 **Bin preparation** \_\_\_\_\_

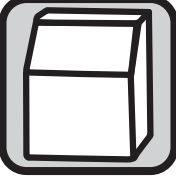

4 **Docking assembly** \_\_\_\_\_

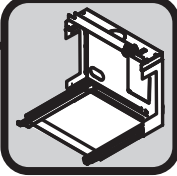

5 **Ice transport tube** \_\_\_\_\_



6 **External connection** \_\_\_\_\_

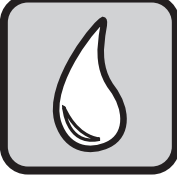

7 **Internal connection** \_\_\_\_\_



8 **Front cover** \_\_\_\_\_



Carefully unpack and inspect the contents of your Follett ice machine.

Unpack

1



### 1.1 Unpack ice machine

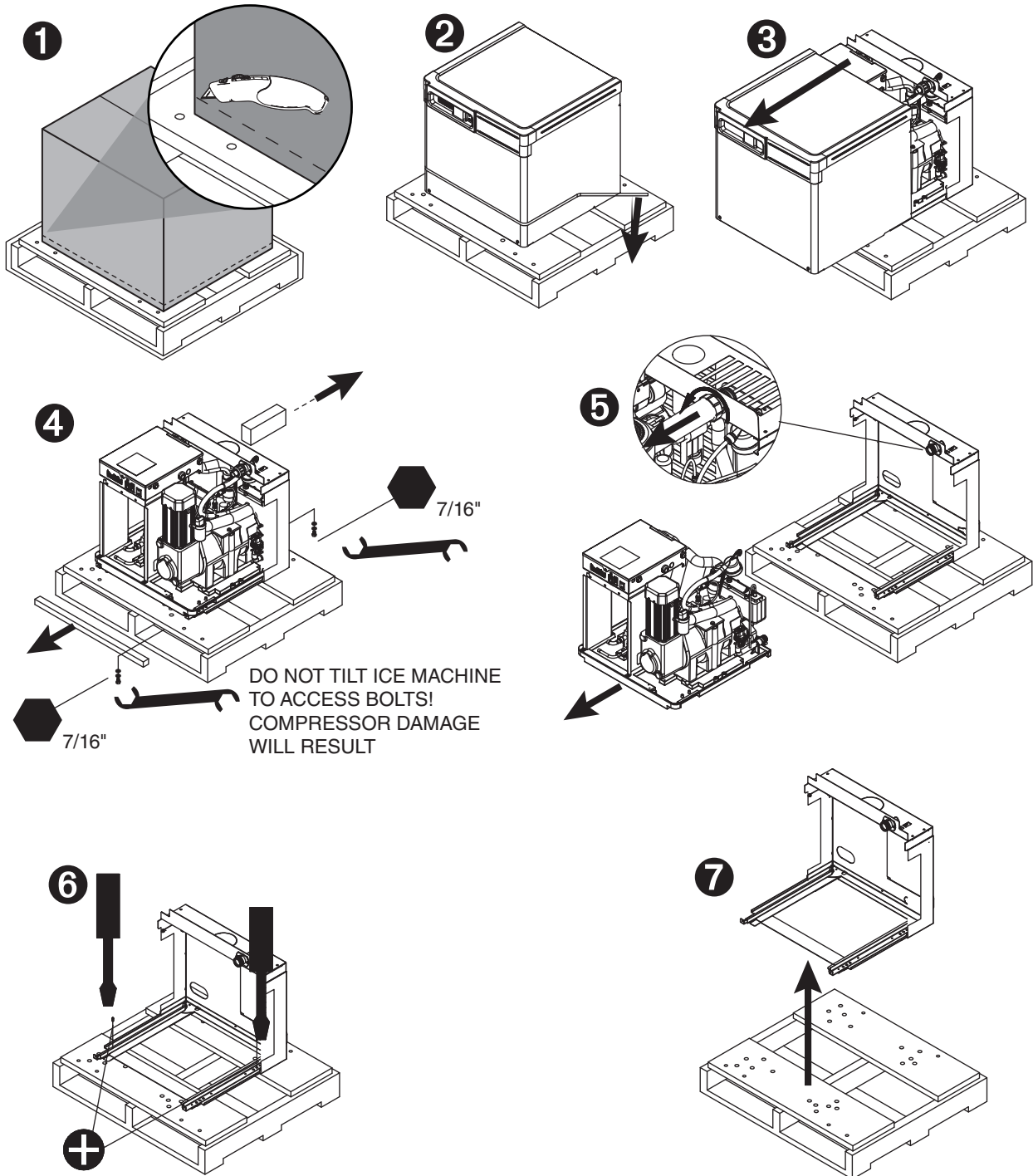

Prepare the installation site.

Provide drainage, water supply and electrical power to within 6 feet (2m) of ice machine in accordance with local and national codes. Outdoor installation is not recommended and will void warranty.

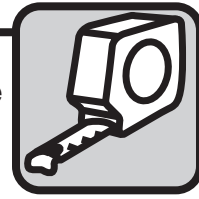

2.1 Installation site requirements

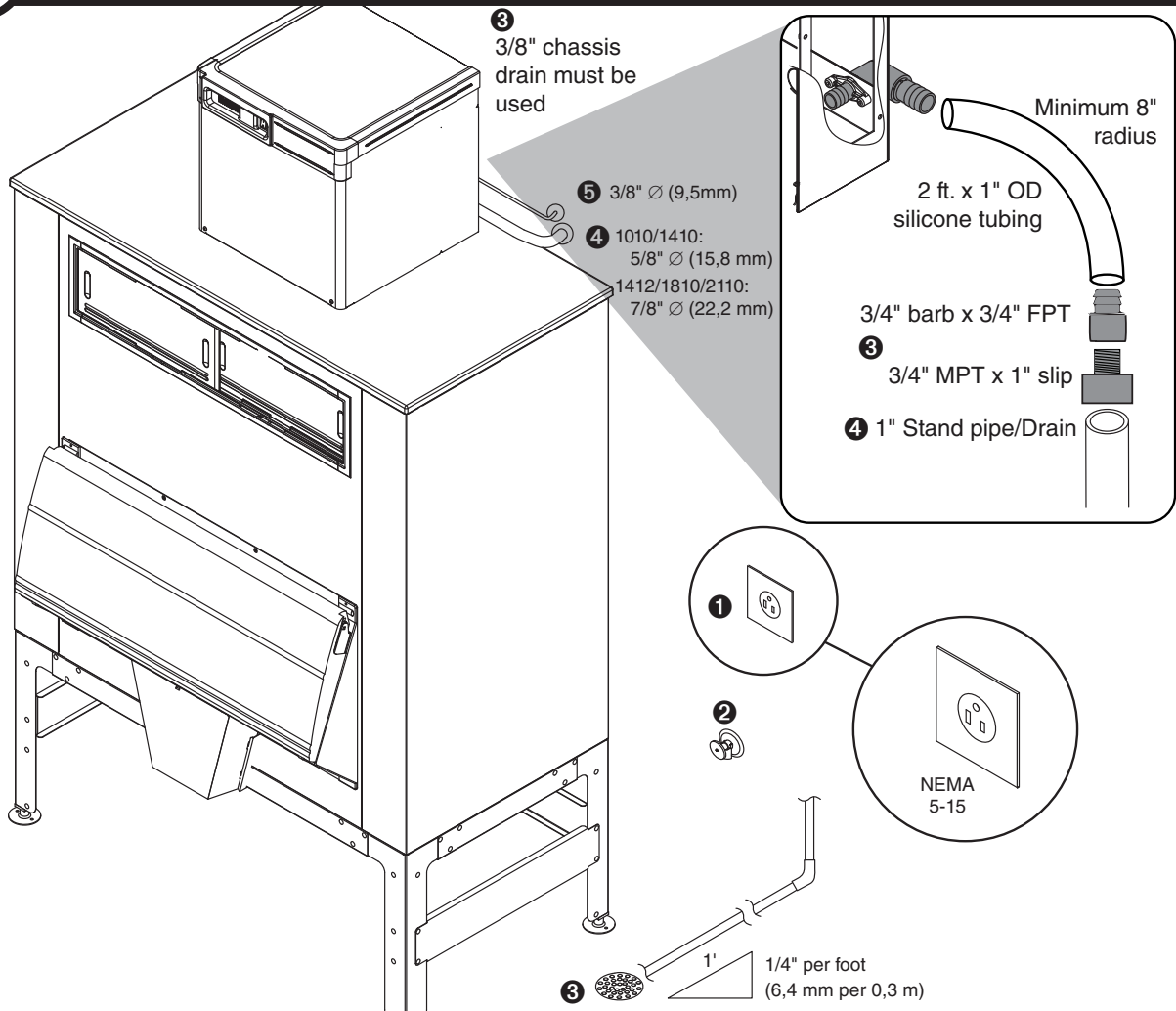

Electrical **1**

- 120/60/1-5 amps

Potable water supply **2** (3/8" push-in connection, 3/8" OD tubing required)

- 10–70 psi (69–483 kpa)
- 45–90 F (7–32 C)
- This equipment is to be installed with adequate backflow protection to comply with applicable federal, state, and local codes

Drains: **3** 3/4" Barb for silicone drain, 3/8" push-to-connect for chassis drain

- Minimum 8" radius on silicone drain line. Drain line from the ice machine must have at least 1/4" per foot pitch (6,4 mm/0,3 m).

Refrigeration lines **4**

- 1010/1410: 5/8"  $\varnothing$  (15,8 mm) diameter suction line (insulated) **4**
- 1412/1810/2110: 7/8"  $\varnothing$  (22,2 mm) diameter suction line (insulated) **4**
- 3/8"  $\varnothing$  (9,5 mm) liquid line **5**

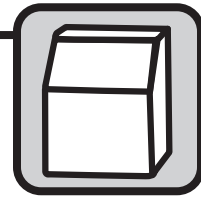

3.1 Bin top preparation

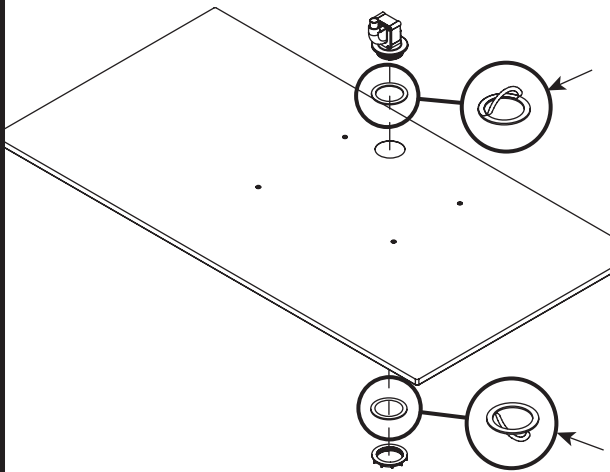

- Remove protective tape from gaskets

3.2 Bin top preparation

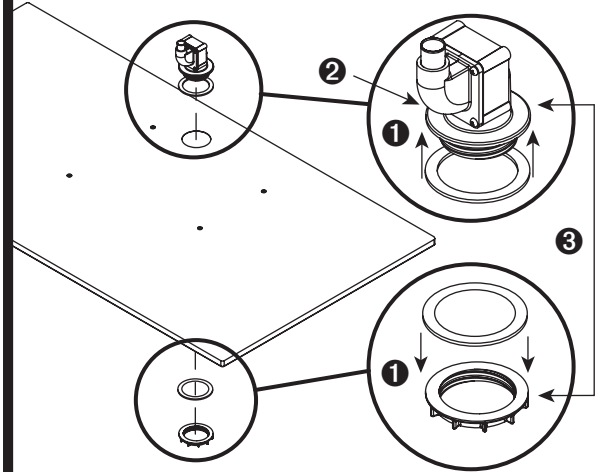

- Apply gaskets ①
- Install shuttle actuator ② through bin top and secure with locking nut ③



BEFORE PROCEEDING

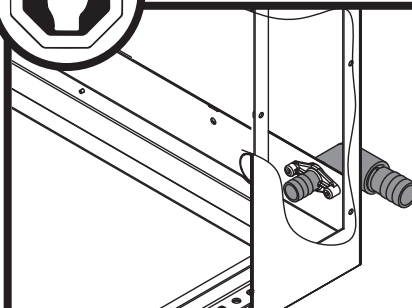

Prior to installing the docking assembly, ensure that the drain fitting is oriented (right or left) correctly for your installation. An optional straight drain fitting is also supplied. You may need to remove the back panel of the docking assembly in order to re-orient or change the drain fitting. Replace back panel prior to mounting the docking assembly.

Install the docking assembly.

## Docking assembly

4

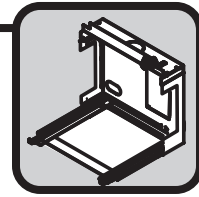

### 4.1 Docking assembly

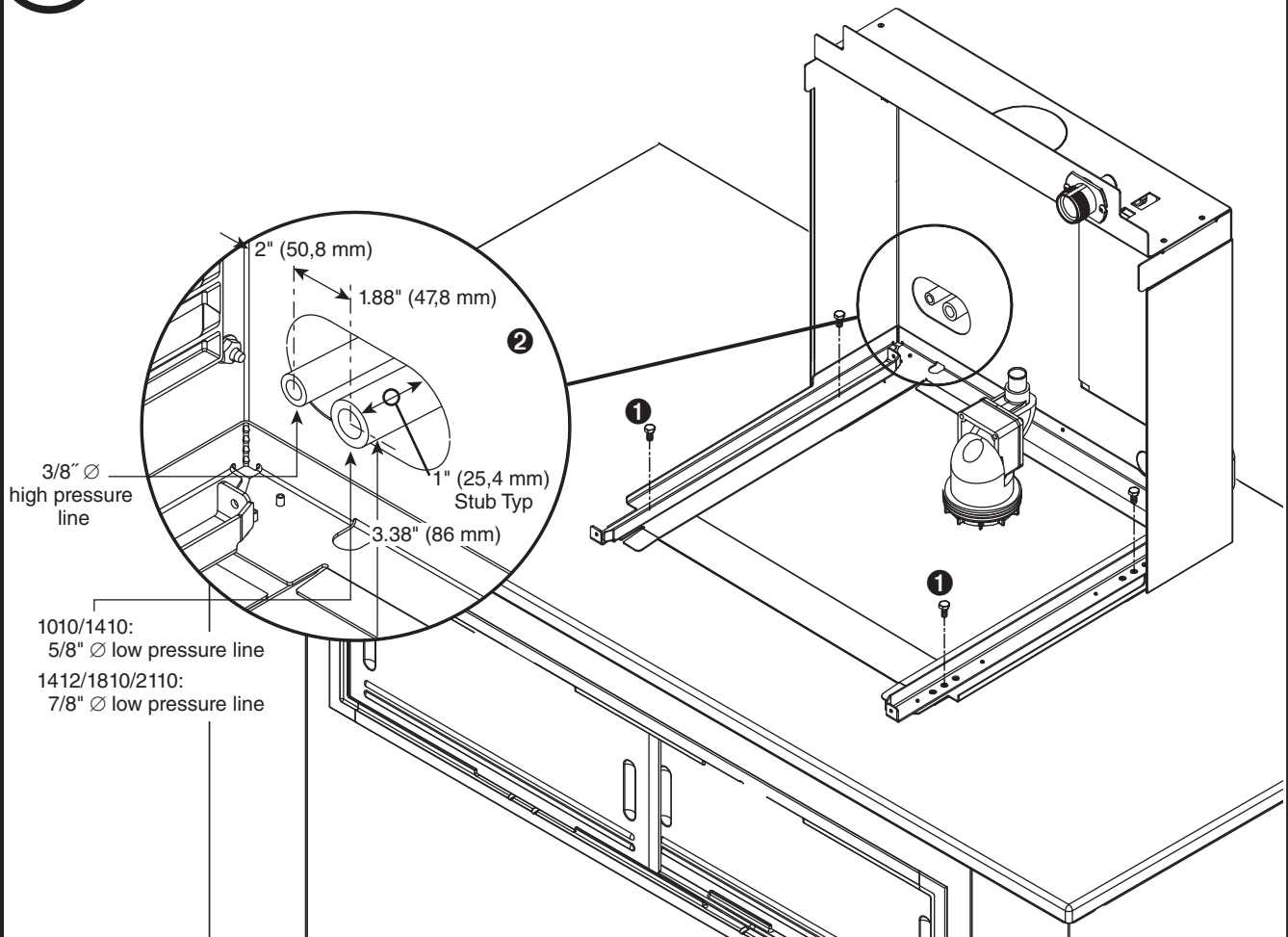

- Mount docking assembly ①
- "Rough-in" the refrigerant piping ②

Install the ice transport tube.

Ice transport tube

5



5.1

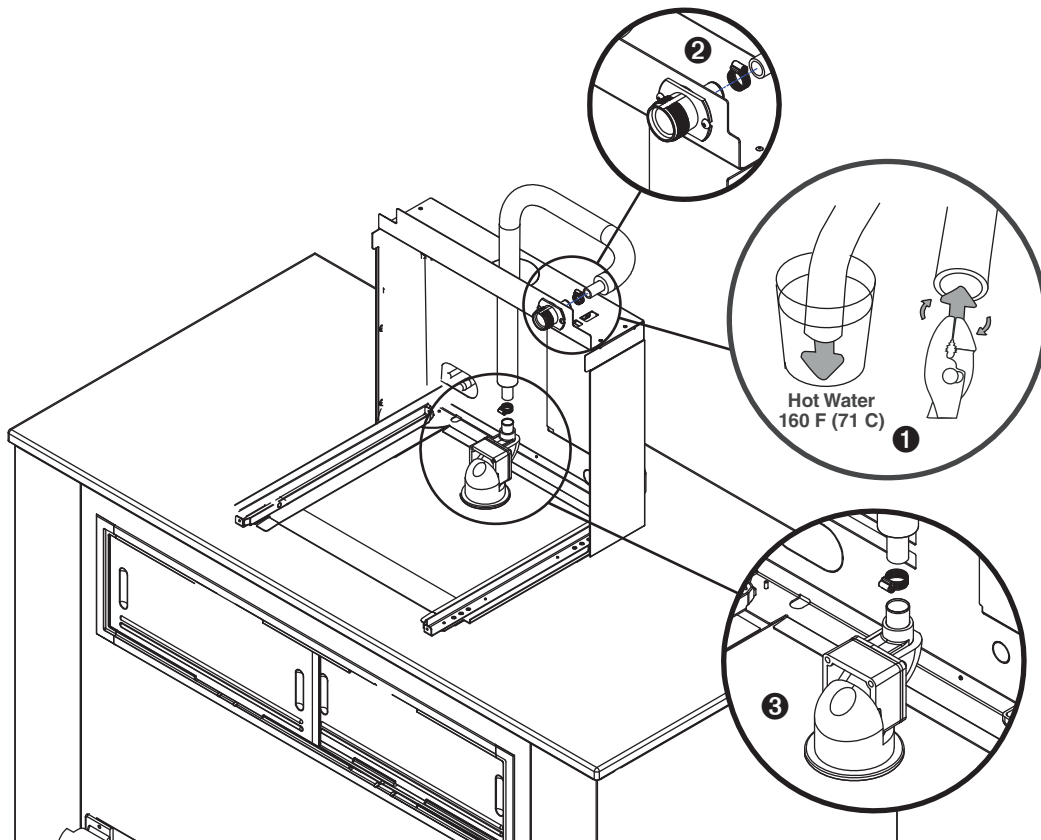

- Slide insulation onto ice transport tube
- Heat end of transport tube in cup of 160 F (71 C) hot water to soften and spread with pliers ❶ before making connection to ease assembly
- Connect ice transport tube to coupling on docking station ❷
- Connect ice transport tube to shuttle actuator ❸



Connect utilities to docking assembly.

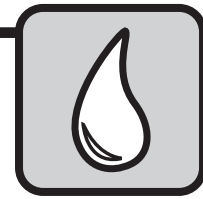

6.1 Water and flush drain

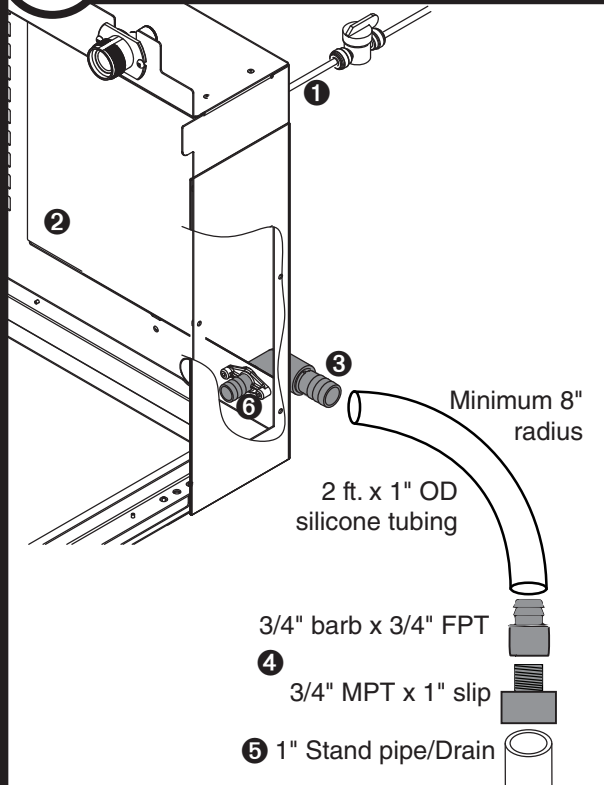

- Rough-in ice machine potable water supply ①. 3/8" push-in connection will be made at included shut-off valve then at back of docking station into solenoid.
  - Remove access panel if necessary ②.
  - Connect the silicone tubing to the ice machine 3/4" drain barb ③.
  - It is recommended that the silicone hose be routed down into a 1.5" or 2" standpipe/drain. The minimum drain size for the ice machine is 1" ④.
- Note: 3/4" to 1" PVC adapter fittings are provided if a larger drain size is not possible.
- If using the fittings, connect the 1" slip fitting to the 1" stand pipe/drain ⑤.
- Note:** Minimum 8" radius on silicone drain line. Drain line from the ice machine must have at least 1/4" per foot pitch (6,4 mm/0,3 m).
- Apply Petrol-gel to barbed drain fitting ⑥
  - Replace access panel.

Chassis drain plumbing - required

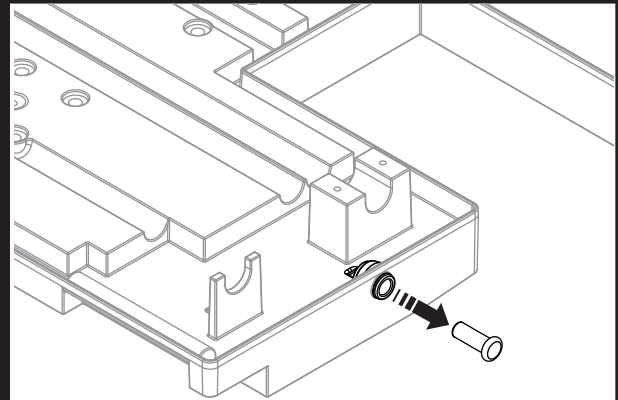

- Plug must be removed from John Guest fitting.
- Route 3/8" OD drain tubing (preferably copper) through rear of docking station and fully insert into chassis base push-in fitting. Route into drain standpipe.
- Gravity drain. Ensure 3/8" OD tubing slopes down into drain standpipe without forming a trap.

6.2 Refrigerant lines

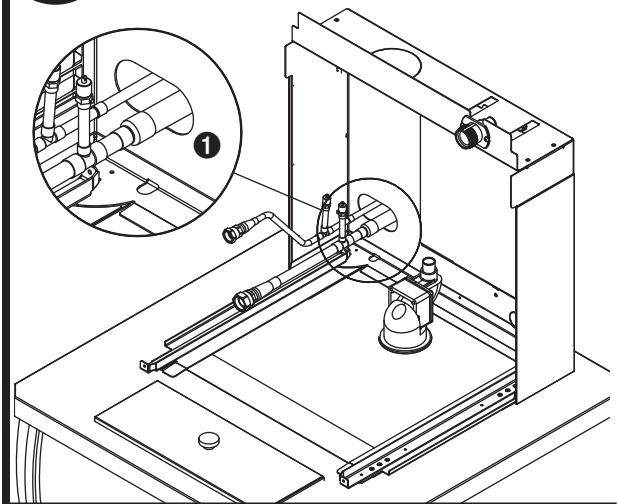

- Braze supplied quick-connect lines onto stub-ins ①.

Connect docking assembly to ice machine.

## Internal connections **7**



### 7.1 Ice transport tube installation

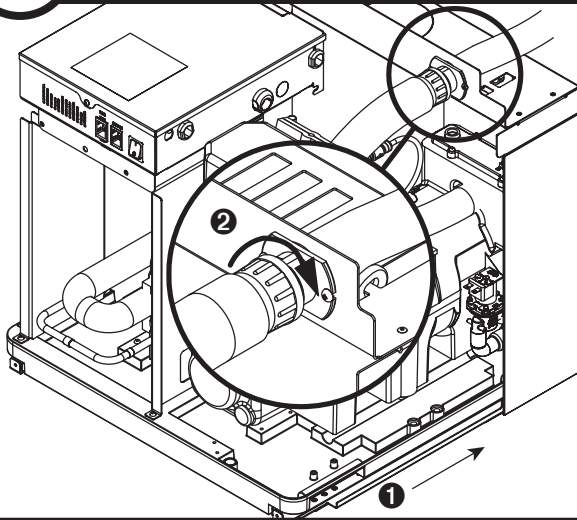

- Slide ice machine into docking assembly ensuring that drain tube is fully seated on barbed drain fitting **1**
- Insert ice transport tube all the way into coupling and tighten nut firmly **2**

### 7.2 Water solenoid, shut-off valve, and potable water line options

**If water solenoid is already mounted to evaporator:**

- Insert potable water line into shut-off valve.

**If this is an undercounter installation:**

- Mount water solenoid atop evaporator and locate the shut-off valve inside the machine. Insert potable water line into shut-off valve.

**If water solenoid is not mounted and machine will not be installed under-counter:**

- Mount water solenoid to *inside* rear (upper right corner) of docking assembly using one screw.
- Insert potable water line into shut-off valve - locate the shut-off valve *outside* the machine.
- Insert outgoing line from shut-off valve into push-in connection of water solenoid.

### 7.3 Refrigeration lines

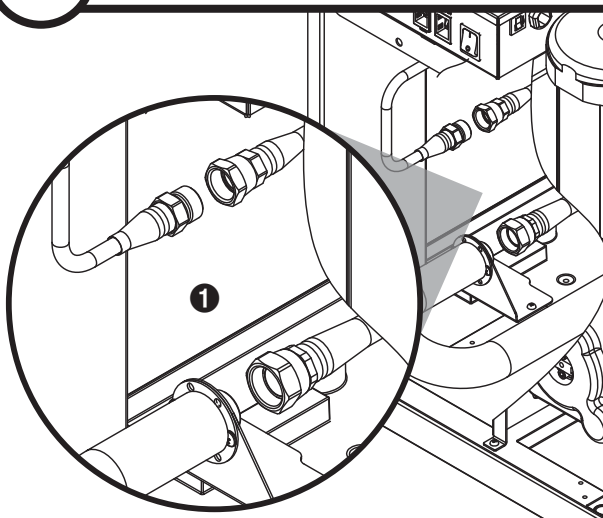

- Evacuate line set.
- Connect self-sealing liquid and suction line fittings **1**

### 7.4 Power cord

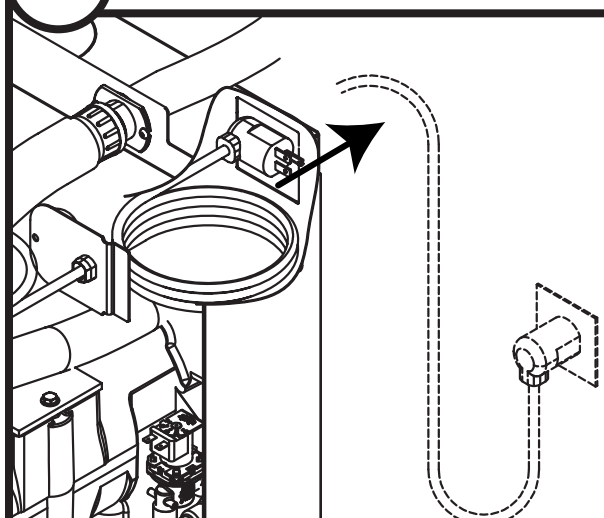

- Remove twist tie
- Carefully pass cord through opening and plug into wall outlet

### 7.5 Power cord

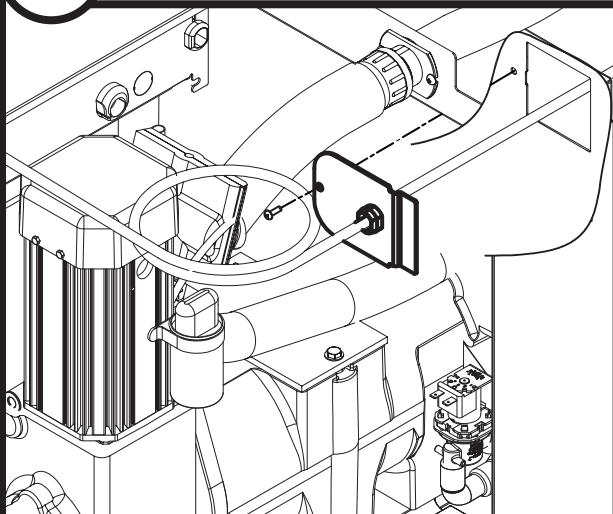

- Position plate into opening and secure with supplied screw

### 7.6 TDS switch

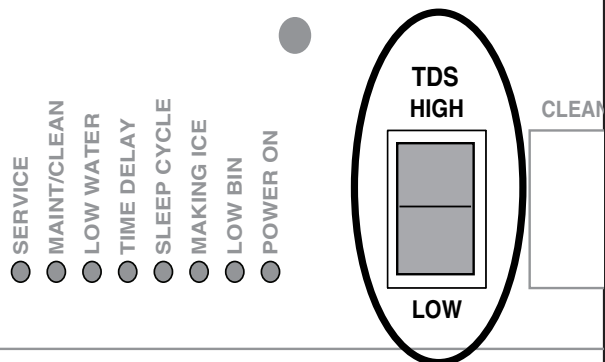

- Set the TDS switch on the electrical box:  
**HIGH:** for extended service life  
**LOW:** for low-scale water

Install front cover to ice machine.

Front cover

8

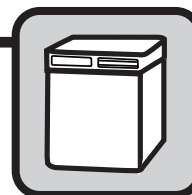

### 8.1 Install condensing unit

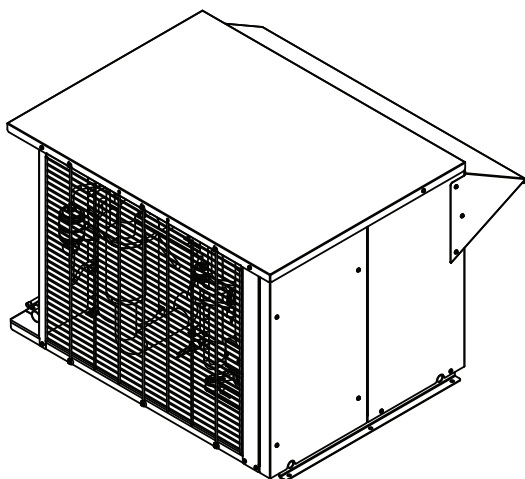

- Complete installation of condensing unit or connection to rack system.
- Required rack system capacity at 0 F (-18 C) evaporator (EPR supplied by installer).

1010CU: 7,700 Btu/hr (1940 kcal/hr)

1410CU: 10,000 Btu/hr (2519 kcal/hr)

1412CU: not rack compatible

1810CU: 15,700 Btu/hr (3956 kcal/hr)

2110CU: 18,200 Btu/hr (4586 kcal/hr).

### 8.2 Install ice machine front cover

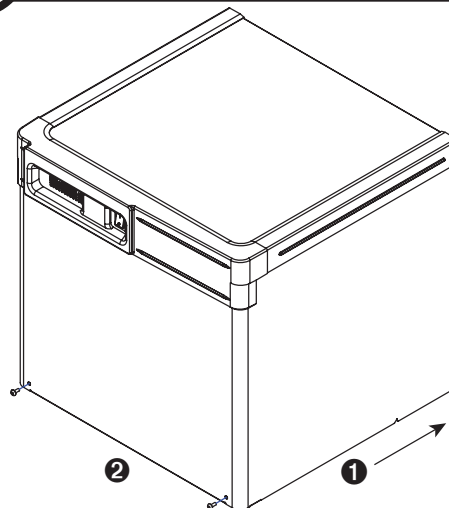

- Slide ice machine cover over machine ①
- Insert and tighten two screws through cover and into docking assembly ②

## NOTICE

**Ice machine MUST be sanitized prior to operation!**

Consult Operation and Service Manual provided with ice machine for sanitizing instructions.

Maestro, Vision, Ice Manager, Horizon Elite are trademarks of Follett Products, LLC.  
Chewblet, RIDE, Follett are registered trademarks of Follett Products, LLC.

**FOLLETT**

801 Church Lane • Easton, PA 18040, USA  
Toll free (877) 612-5086 • +1 (610) 252-7301  
www.follettice.com

01565068R00  
© Follett Products, LLC 11/24