

# Horizon Elite™ Ice Machine with RIDE™ Technology Installation Instructions for Ice and Beverage Dispenser Applications

D710, E710, C1010, C1410

Order parts online  
[www.follettice.com](http://www.follettice.com)

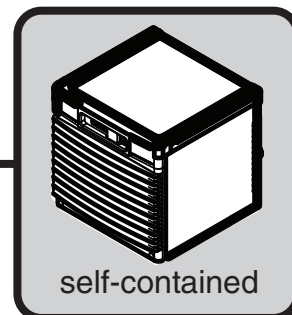

**Horizon Elite ice machines with RIDE technology  
to fit most countertop dispensers manufactured by  
Cornelius • Lancer • Servend**

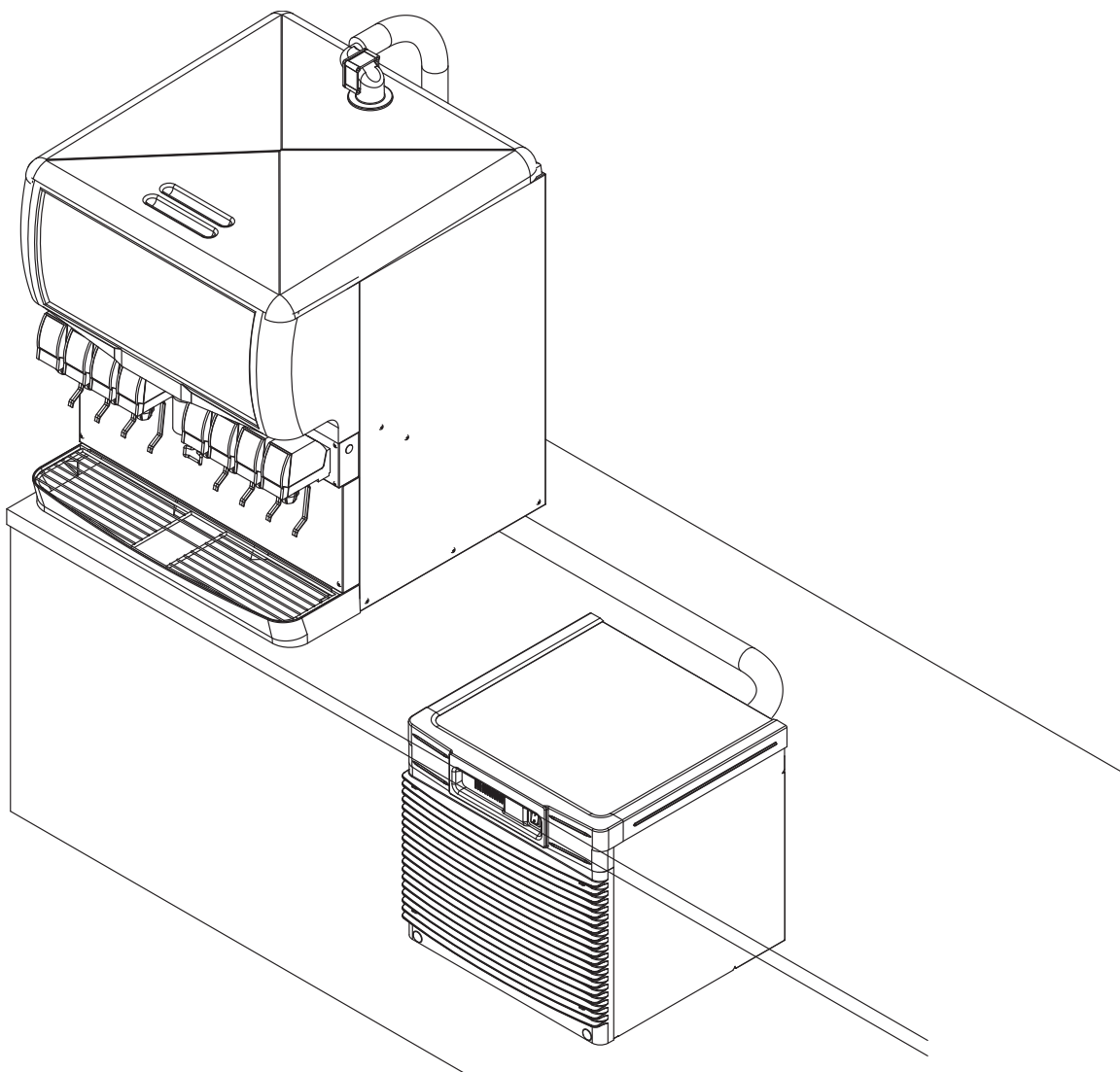

801 Church Lane • Easton, PA 18040, USA  
Toll free (877) 612-5086 • +1 (610) 252-7301  
[www.follettice.com](http://www.follettice.com)

01113224R07

 **CAUTION!**

- This appliance should be connected by a qualified person in accordance with applicable codes.
- If the supply cord is damaged, it must be replaced by the manufacturer, its service agent or similarly qualified persons in order to avoid a hazard.
- Connect to potable water supply only.
- This appliance can be used by children aged 8 years and above and persons with reduced physical, sensory, or mental capabilities, or lack of experience and knowledge if they have been given supervision or instruction concerning use of the appliance in a safe way and understand the hazards involved. Children should be supervised to ensure that they do not play with the appliance.
- This appliance is intended to be used for household and similar applications such as staff kitchen areas in shops, offices and other working environments; farm houses and by clients in hotels, motels and other residential type environments; bed and breakfast type environments; catering and similar non-retail applications.
- **WARNING!** To avoid a hazard due to instability of the appliance, it must be fixed in accordance with the instructions.

# Contents

<b>Unpack</b> .....	<b>4</b>
Unpack Ice Machine .....	4
<b>Site Preparation</b> .....	<b>5</b>
Installation site requirements .....	5
<b>Dispenser Top Preparation</b> .....	<b>6</b>
Top preparation .....	6
Install shuttle actuator .....	6
<b>Mount Ice Machine</b> .....	<b>7</b>
Ice machine in cabinet .....	7
<b>External Connections</b> .....	<b>10</b>
Transport tube installation .....	10
Air-cooled ice machines only .....	12
Water-cooled ice machines only .....	12
<b>Internal Connections</b> .....	<b>13</b>
Ice transport tube .....	13
Potable water lines .....	13
Power cord .....	13
Power cord .....	13
TDS switch .....	14
Cooling Lines .....	14
Ice transport tube .....	14
Potable Water Line .....	15
Cooling lines and power .....	15
Power cord .....	15
Plate .....	15
TDS switch .....	16
<b>Front Cover</b> .....	<b>17</b>
Install cover - undercounter air-cooled application only .....	17
Install front cover .....	17
<b>Dispenser Agitation Adjustment</b> .....	<b>18</b>
Agitation adjustments – CORNELIUS .....	18
Agitation adjustments – Lancer 4500 Series .....	18
Agitation adjustments – Lancer FS Series .....	19
Agitation adjustments – Servend .....	19
Dispenser diverter plate overview – Cornelius, ED, DF AND DB Series (installation on next page) .....	20
Dispenser diverter plate installation – Cornelius, ED, DF AND DB Series .....	21
<b>RIDE model ice machine start up procedure</b> .....	<b>22</b>
Before turning on power .....	22
After turning on power .....	22

# 1. Unpack

Carefully unpack and inspect the contents of your ice machine.

## 1.1 Unpack Ice Machine

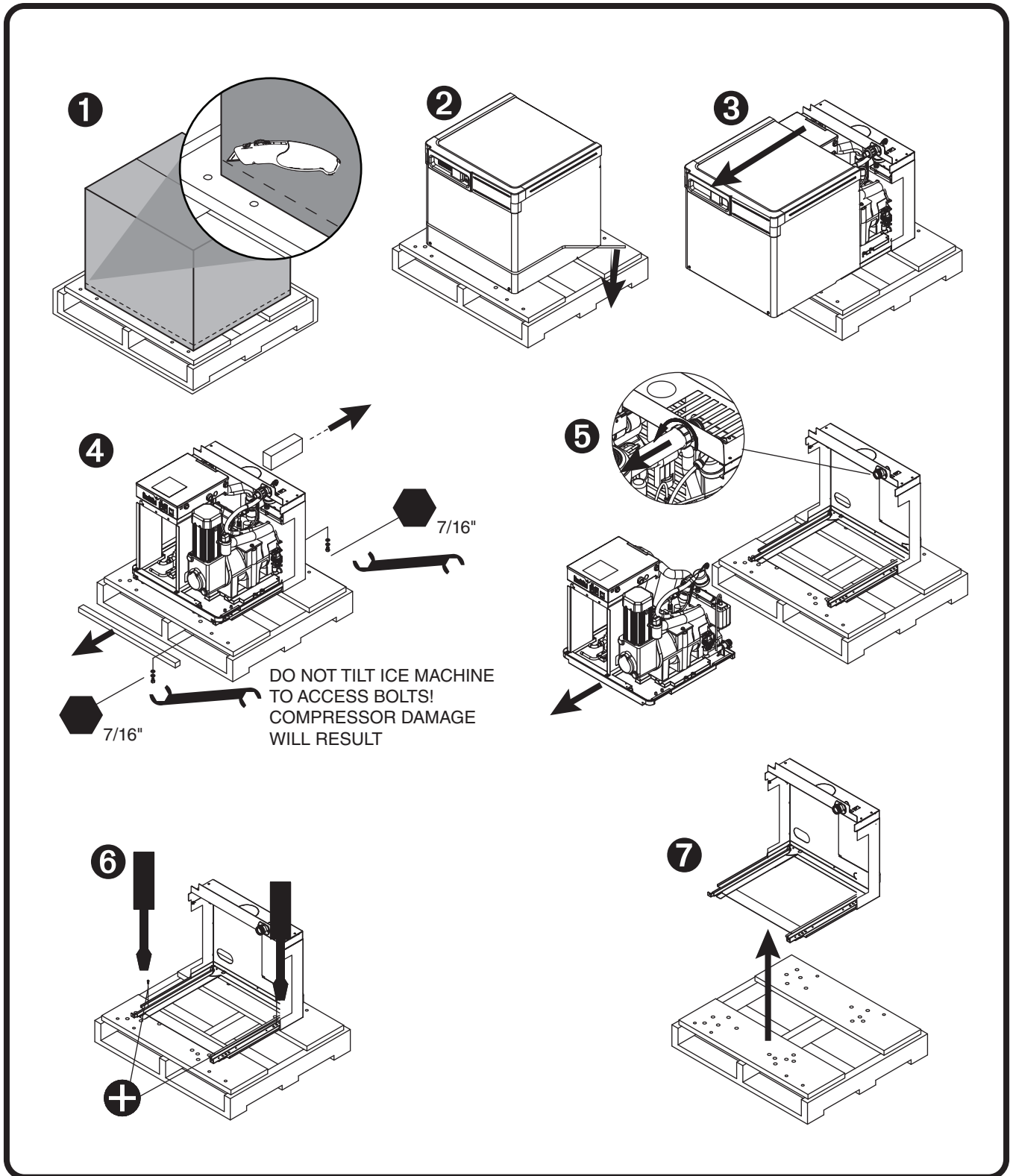

## 2. Site Preparation

Provide drainage, potable water supply and electrical power to within 6 feet (2 m) of ice machine in accordance with local and national codes. Outdoor installation is not recommended and will void warranty.

### 2.1 Installation site requirements

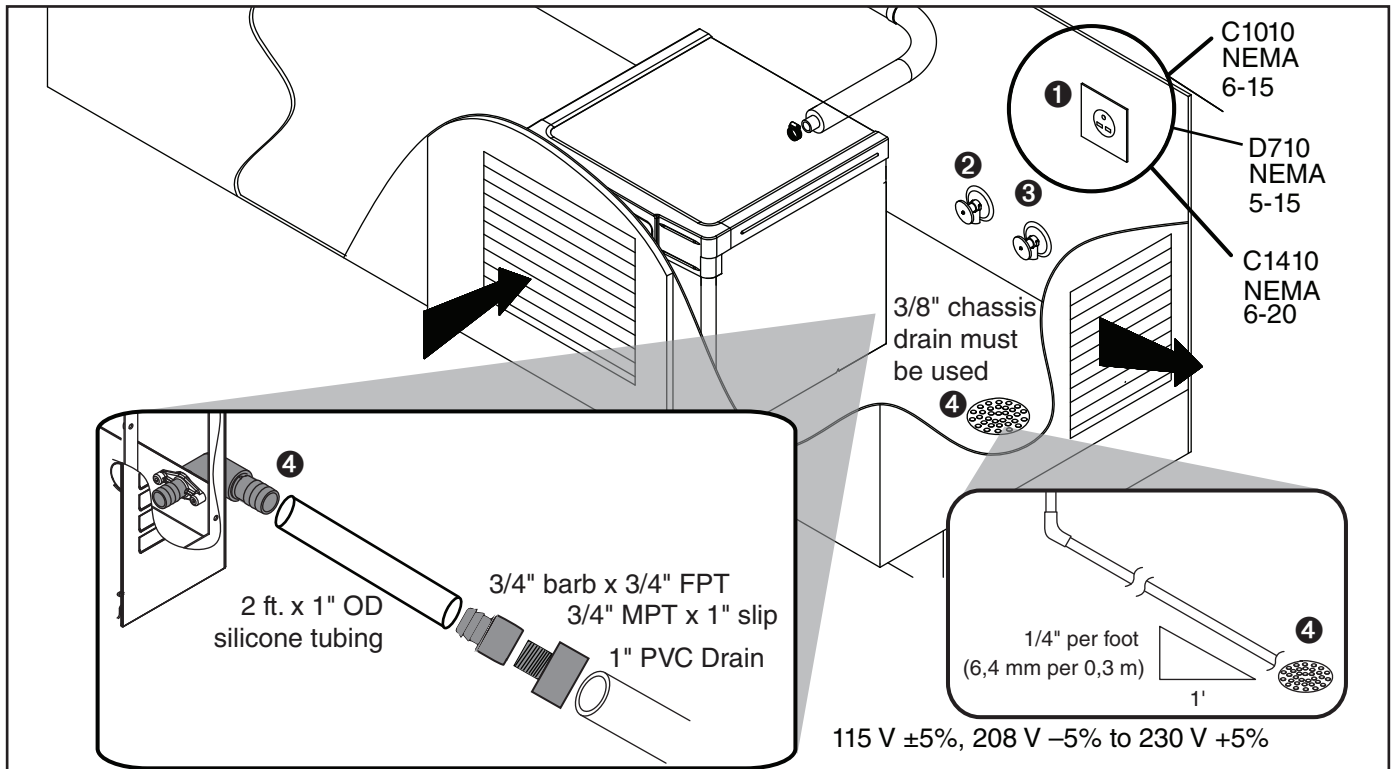

#### Electrical ❶

#### ⚠ WARNING!

- This appliance should be connected by a qualified person in accordance with applicable codes.
- If the supply cord is damaged, it must be replaced by the manufacturer, its service agent or similarly qualified persons in order to avoid a hazard.

C1010, C1410 208-230/60 breaker

\* Requires a 15A dedicated circuit.

D710 115/60

Requires a 15A dedicated circuit.

E710 230/50†

‡ E710 requires 15A dedicated circuit 1.50 mm<sup>2</sup> wire,. Plug must be provided by end user and must conform to standard EN 60 335-2-24 of the end destination.

#### Potable Water Supply ❷ (3/8" push-in connection, 3/8" OD tubing required)

10 psi to 70 psi (69 kpa to 483 kpa)

45 F to 90 F (7 C to 32 C)

- This equipment is to be installed with adequate backflow protection to comply with applicable federal, state, and local codes

#### Condenser water supply for water-cooled systems ❸ (1/4" FPT inlet, 1/4" FPT outlet)

10 psi min.; 150 psi max. (69 kpa min.; 1034 kpa max.)

20 F to 90 F (-7 C to 32 C)

1.5 gallons (5.68 liters) per minute

#### Drains ❹ 3/4" Barb for silicone drain, 3/8" push-to-connect for chassis drain

Minimum 8" radius on silicone drain line. The drain line from the ice machine must have at least 1/4" per foot (6,4 mm/0,3 m) pitch

### 3. Dispenser Top Preparation

#### **WARNING!**

- Prior to installing the docking assembly, ensure that the drain fitting is oriented (right or left) correctly for your installation. An optional straight drain fitting is also supplied. You may need to remove the back panel of the docking assembly in order to re-orient or change the drain fitting. Replace back panel prior to mounting the docking assembly.
- Docking station must be secured in accordance with these instructions to ensure ice machine stability.
- Ventilation openings in the docking station should be clear of obstruction. Failure to do so could result in damage to equipment.
- Plug must be accessible after final installation.

#### 3.1 Top preparation

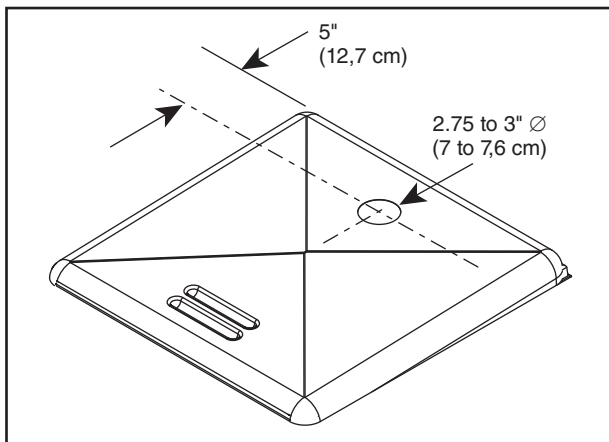

- Locate shuttle actuator hole 5" (127 mm) from back of dispenser top.
- Cut a 2.75" to 3" (7 to 7,6 cm) diameter hole in dispenser top for shuttle actuator.

#### 3.2 Install shuttle actuator

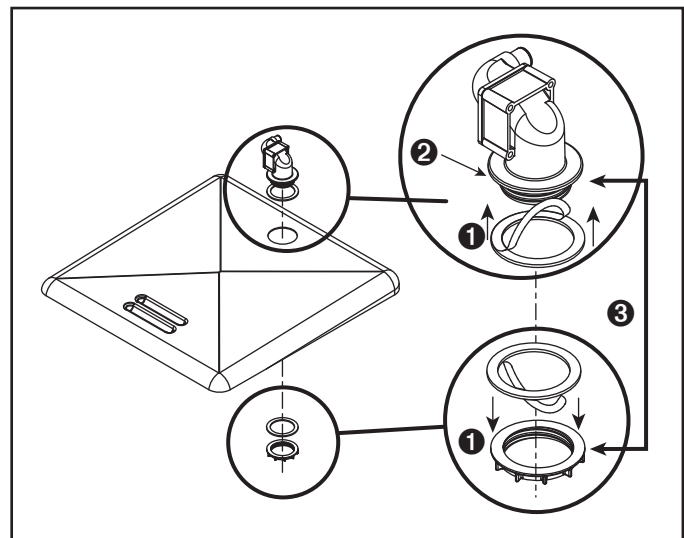

- Apply gaskets **1**.
- Install shuttle actuator **2** through dispenser top and secure with locking nut **3**.

## 4. Mount Ice Machine

### Mounting options: Cabinet, Wall, Stand

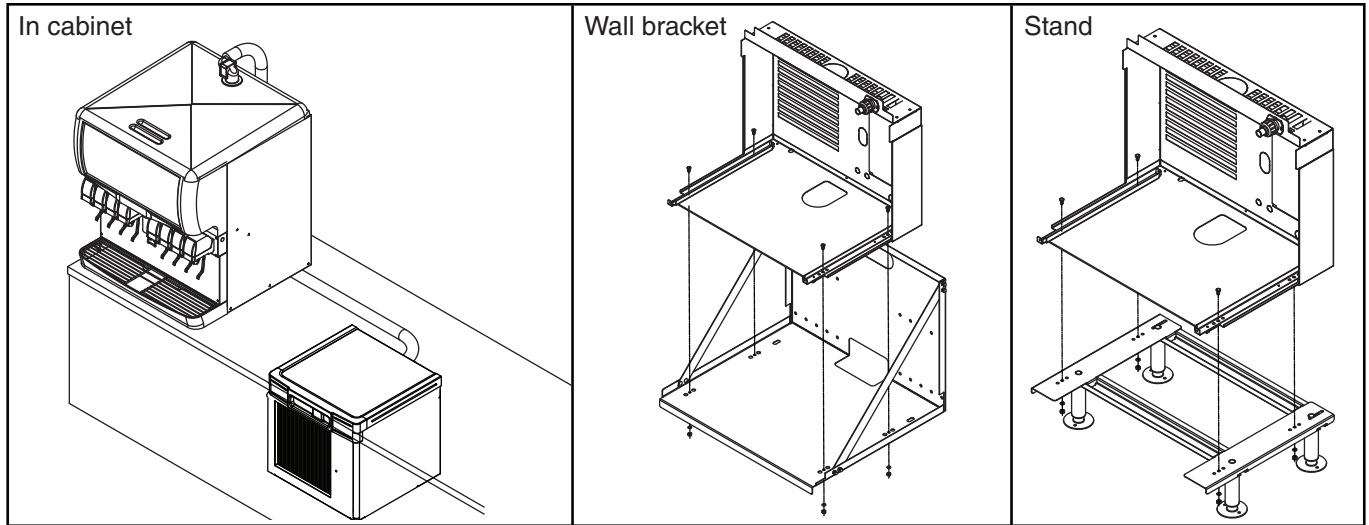

### 4.1 Ice machine in cabinet

Ice machines can be installed undercounter/in-cabinet to fill bins or dispensers using RIDE technology. Care must be taken to ensure proper cabinet venting to avoid recirculation of hot air. Improper venting can cause ice machine outages.

#### **DOCKING STATION: Horizon** (See detail drawing on page 8)

- Position and screw docking assembly to the bottom of counter inside of access panel/door **1**  
1010/1410: 2.25" (57 mm) from the front edge of assembly  
710: 3.25" (83 mm) from the front edge of the cross brace
- The mounting surface for the docking assembly must be solid.  
Do not mount directly onto runners or channels.
- There must be no lip or edge that would hinder the ice machine from sliding in or out of the docking station **2**

#### **INTAKE AND EXHAUST GRILLE PLACEMENT: Air-cooled models only** (See detail drawing on page 9)

- Position the intake grille cut out in the access panel/door  
**Note:** Ice machine must be aligned with cut out and inside of access panel to provide a tight seal and prevent recirculation of hot exhaust air.
- Left edge of cutout from the left side of the ice machine **3**  
1010/1410: 2.25" (57 mm)  
710: 2" (51 mm)
- Bottom edge of cutout should be 2" (51 mm) from the bottom of the ice machine **4**
- Position supplied exhaust grille at least 18" (458 mm) away from intake grille **5**.  
Where possible, install exhaust grille to the rear or side of the base cabinet.
- If not using supplied grille, air circulation requirements below must be met:  
1010/1410: 250 sq. in (1613 sq cm) intake/exhaust air  
710: 160 sq. in (1032 sq cm) intake/exhaust air

**Front View**

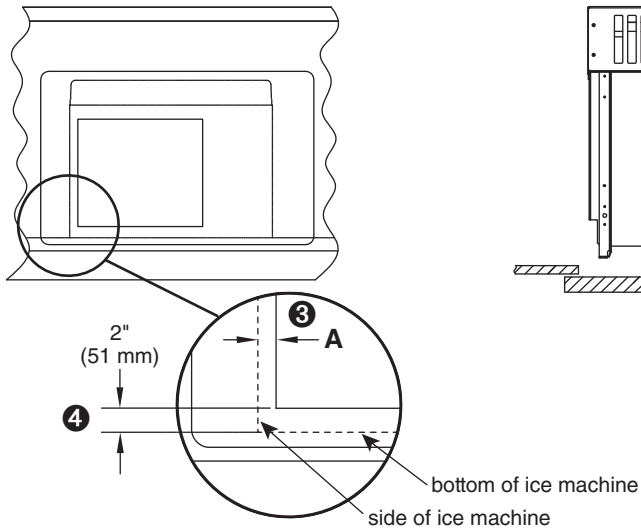

**Top View**

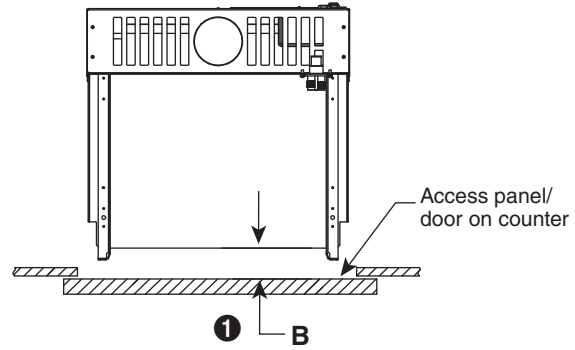

<b>A</b>	1010/1410: 2.25" (57 mm)
	710: 2" (51 mm)
<b>B</b>	1010/1410: 2" (51 mm)
	710: 3.25" (82.55 mm)

**! CAUTION**

- Keep ventilation openings in the appliance enclosure clear of obstruction. Failure to do so could result in damage to equipment.
- To ensure proper ventilation (if not using supplied grille) carefully review air circulation specifications on previous page (4.1)

**3D Counter View**

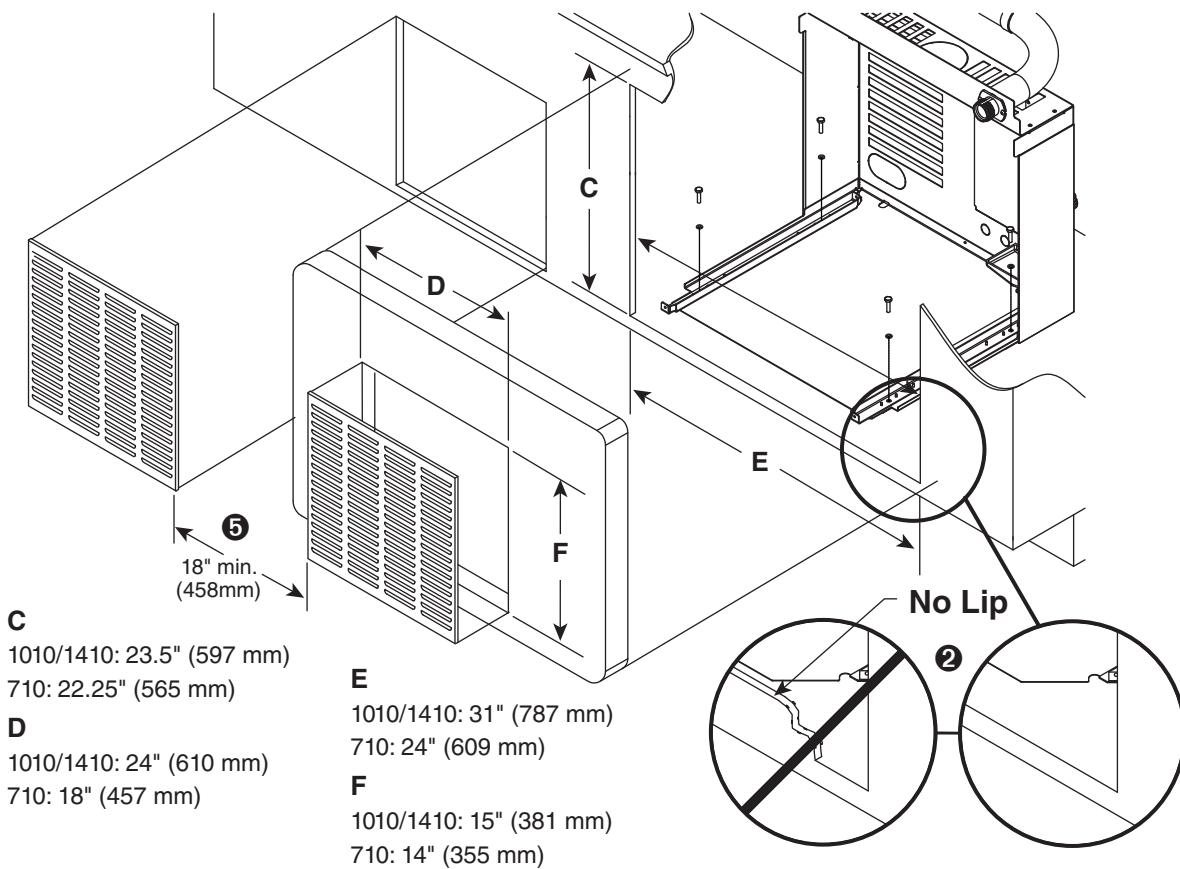



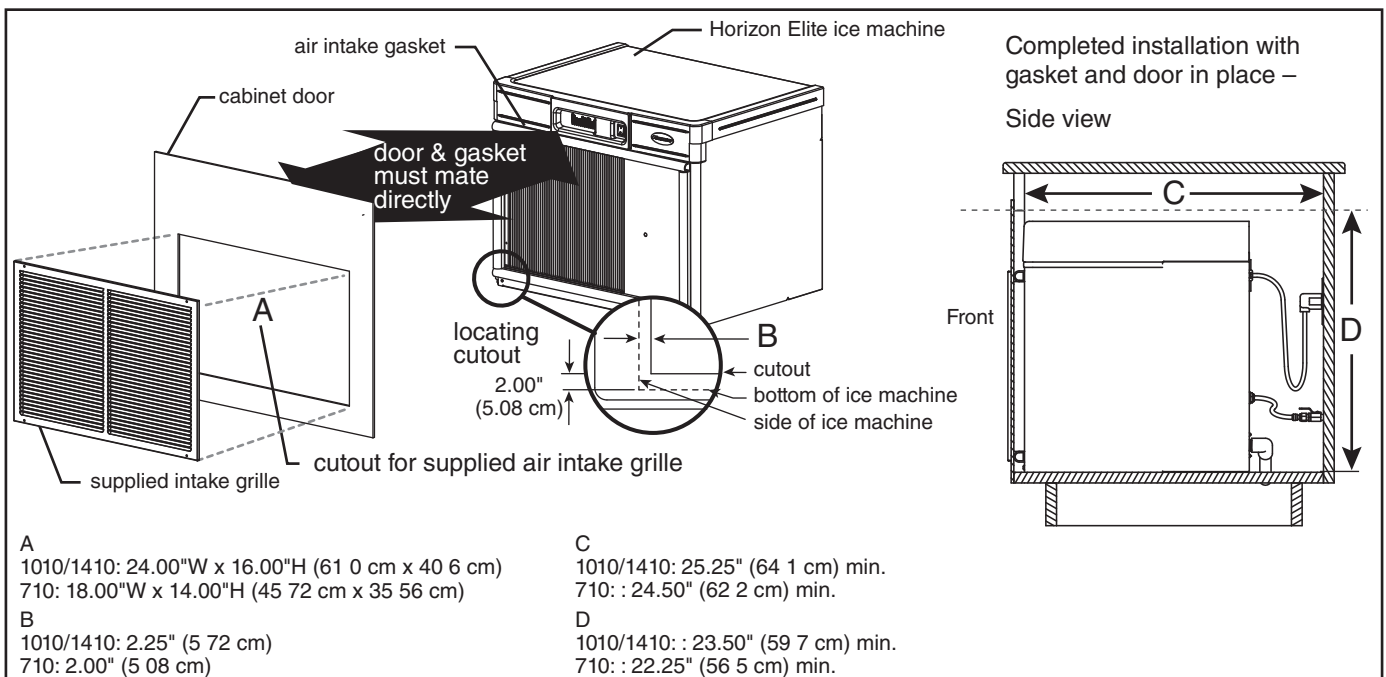
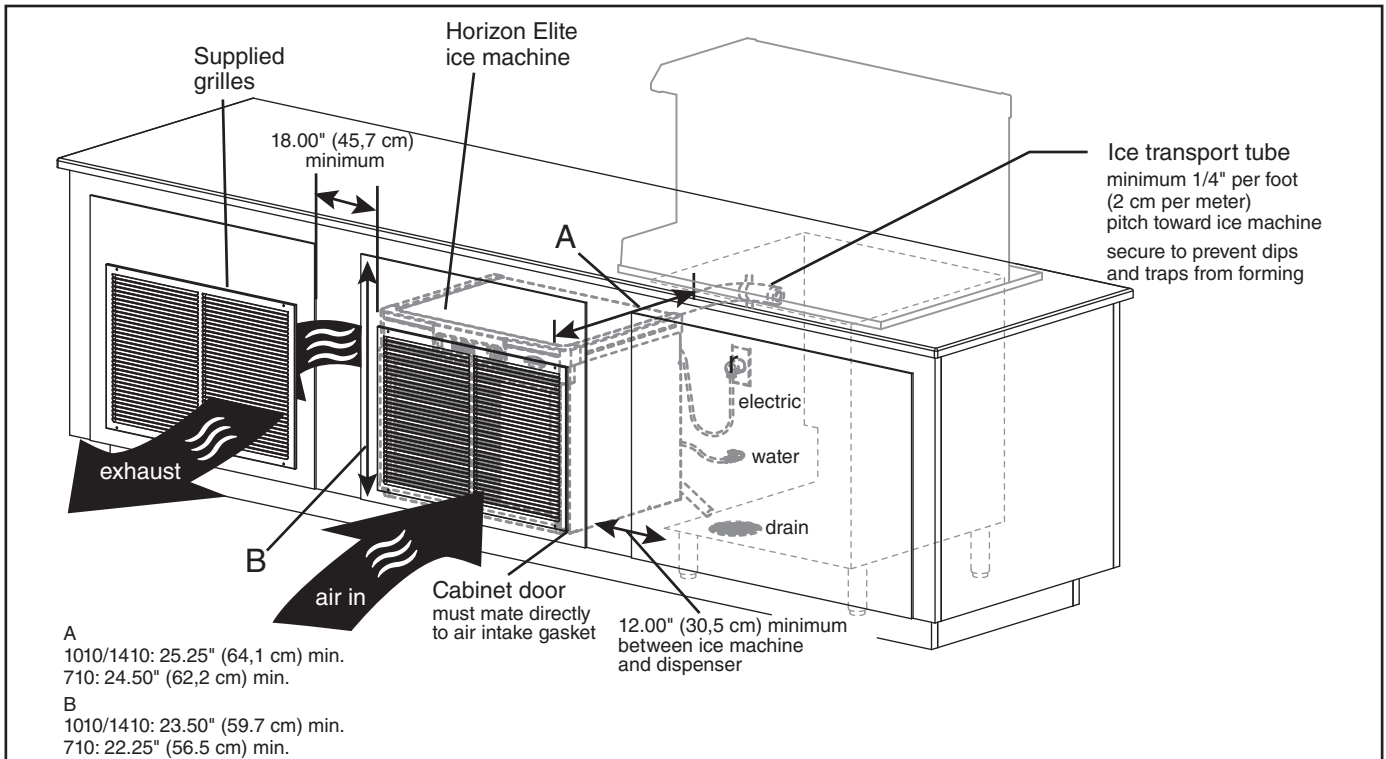

- The supplied exhaust grille must be located at least 18" (46 cm) from the supplied air intake grille (exhaust air must not recirculate with intake air).
- Cabinet interior must be open to allow for unrestricted exhaust air flow.
- Ice transport tube needs minimum 1/4" per foot (2 cm per meter) pitch toward ice machine and should be secured to prevent dips and traps from forming.
- Cabinet door must mate directly to air intake gasket.
- Cabinet interior must provide a minimum clear space of 25.25" deep (64,1 cm) by 23.5" high (59,9 cm) for 1010/1410, and 24.50" deep (62,2 cm) by 22.25" high (56,5 cm) for 710.
- Cutout for supplied grilles must meet minimum size requirements shown above.
- Utilities should be conveniently located as shown.

## 5. External Connections

### 5.1 Transport tube installation

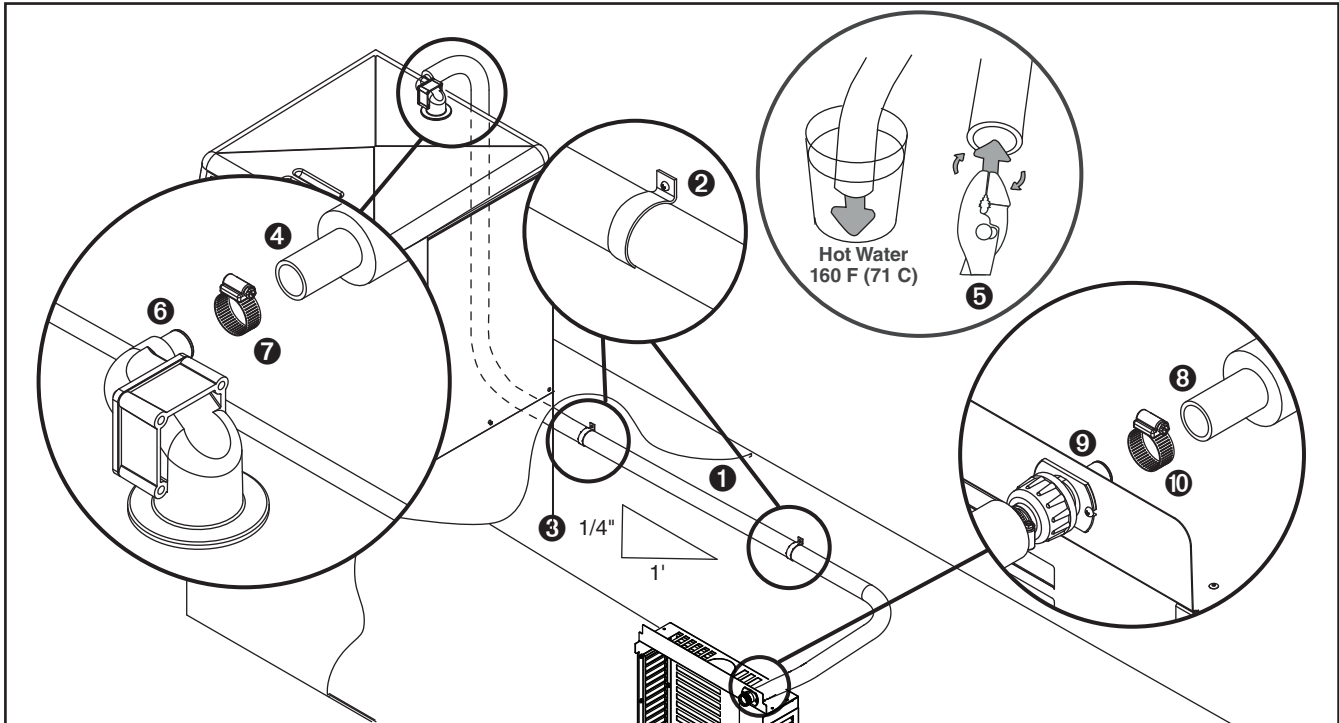

#### Ice transport tube tips

- Insulate entire length of ice transport tube ①
- Secure ice transport tube ② as needed to prevent dips and traps from forming. For long tube runs see next page.
- Pitch ice transport tube at least 1/4" per foot (6,4mm/0.3m) ③
- Ice transport tube must drain towards ice machine

#### Ice transport tube to dispenser

- Be sure tube ends are square ④
- Heat end of transport tube in cup of 160 F (71 C) hot water to soften and spread with pliers ⑤ before making connection to ease assembly
- Push ice transport tube onto ice machine nipple ⑥
- Install hose clamp ⑦

#### Ice transport tube to Ice machine

- Be sure tube ends are square ⑧
- Heat end of transport tube in cup of 160 F (71 C) hot water to soften and spread with pliers ⑤ before making connection to ease assembly
- Push ice transport tube onto ice machine nipple ⑨
- Install hose clamp ⑩

### 5.1.1 Long tube run recommendations

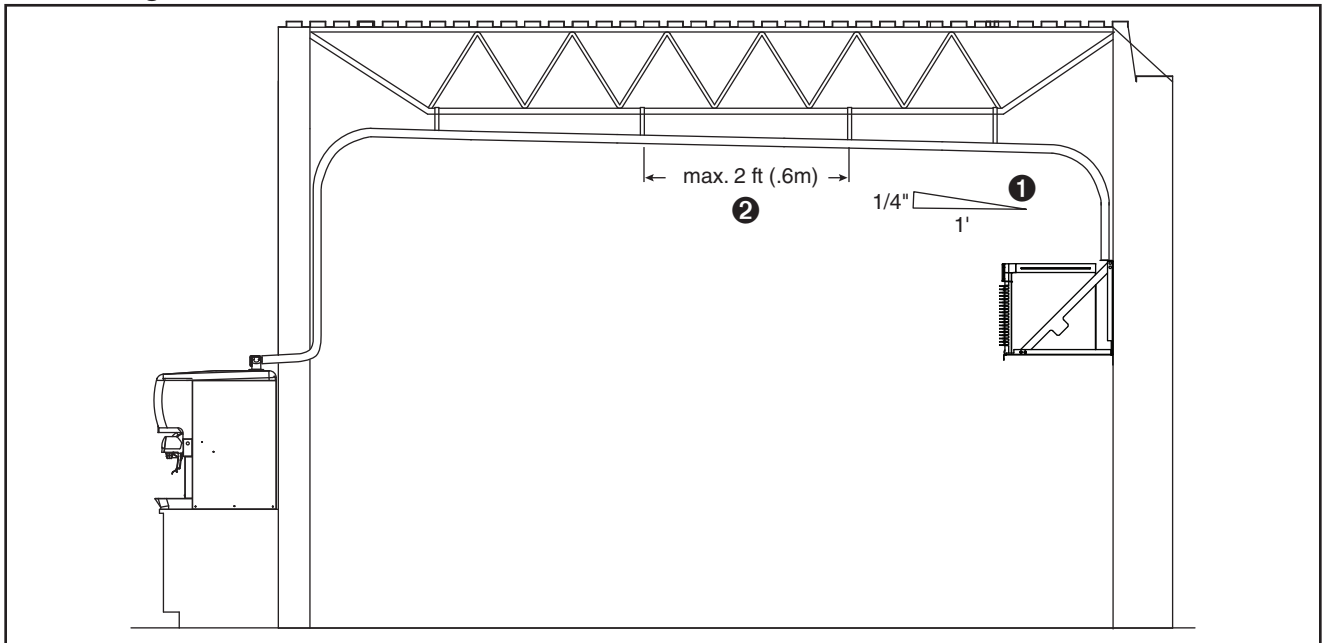

- Pitch ice transport tube to allow melt water to drain towards ice machine ①
- Secure insulated ice transport tube at least every 2 ft (0,6m) to prevent dips or traps ②
- Maximum length of transport tube is 75' (22 5 m).
- Maximum rise is 20' (7 5 m).
- Maximum length of transport tube for Micro Chewblet applications is 10' (3 m).

## 5.2 Air-cooled ice machines only

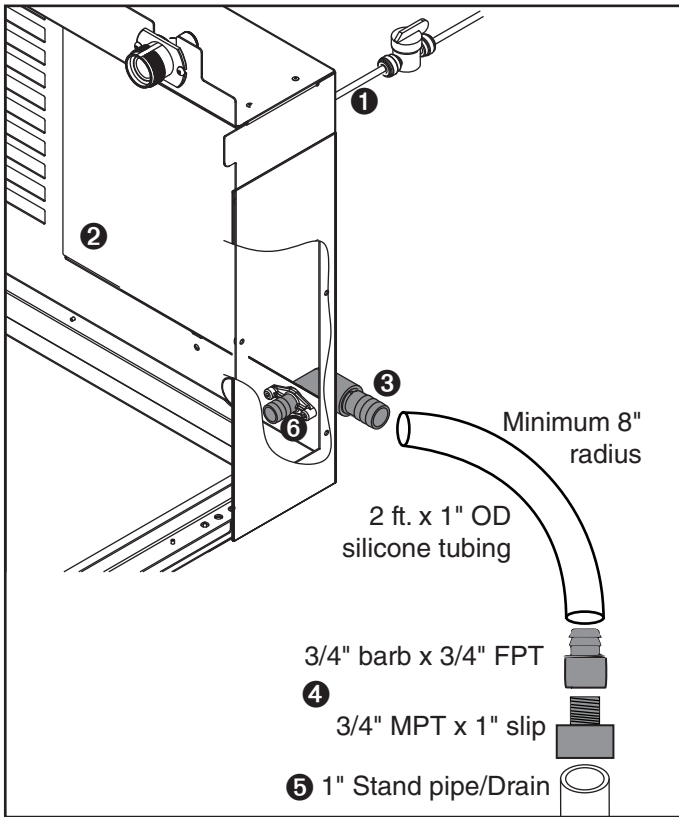

- Rough-in ice machine potable water supply ①. 3/8" push-in connection will be made at included shut-off valve then at back of docking station into solenoid.
- Remove access panel if necessary ②.
- Connect the silicone tubing to the ice machine 3/4" drain barb ③.
- Assemble the 3/4" barb x 3/4" FPT to the 3/4" MPT x 1" slip. Connect the other end of the silicone tubing to the 3/4" barb ④.
- Connect the 1" slip fitting to the 1" stand pipe/drain ⑤.

**Note: Minimum 8" radius on silicone drain line. Drain line from the ice machine must have at least 1/4" per foot pitch (6,4mm/0,3m).**

- Apply Petrol-gel to barbed drain fitting ⑥
- Replace access panel.

## 5.3 Water-cooled ice machines only

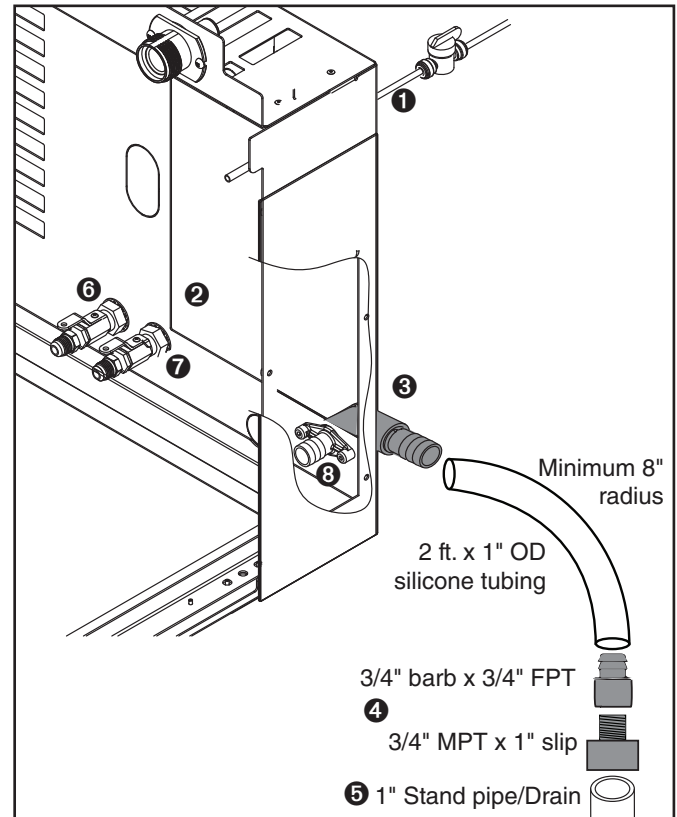

- Rough-in ice machine potable water supply ①. 3/8" push-in connection will be made at included shut-off valve then at back of docking station into solenoid.
- Remove access panel if necessary ②.
- Connect the silicone tubing to the ice machine 3/4" drain barb ③.
- Assemble the 3/4" barb x 3/4" FPT to the 3/4" MPT x 1" slip. Connect the other end of the silicone tubing to the 3/4" barb ④.
- Connect the 1" slip fitting to the 1" stand pipe/drain ⑤.

**Note: Minimum 8" radius on silicone drain line. Drain line from the ice machine must have at least 1/4" per foot pitch (6,4mm/0,3m).**

- Connect cooling water supply ⑥ and return ⑦
- Apply Petrol-gel to barbed drain fitting ⑧
- Replace access panel.

## 5.4 Chassis drain plumbing - required

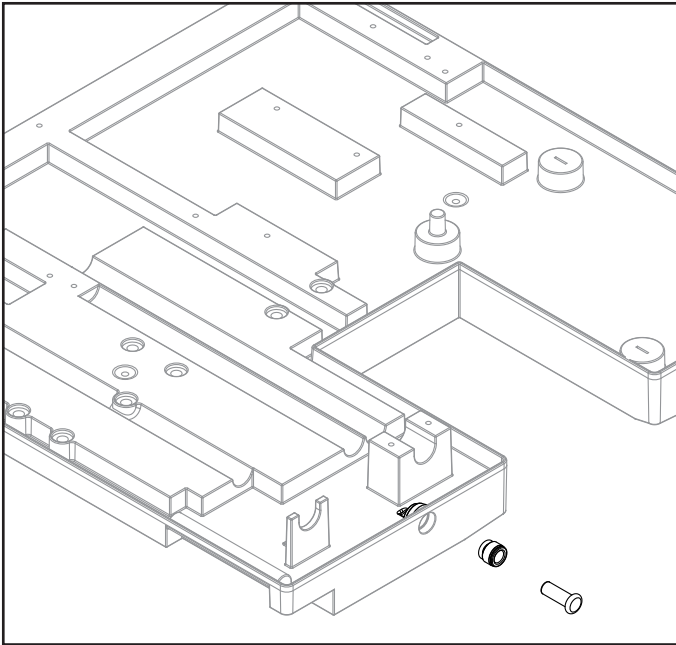

- Plug must be removed from John Guest fitting.
- Route 3/8" drain tubing through knockout in back of docking station and insert fully into John Guest fitting connection at the rear of the machine chassis. Route other end of 3/8" drain tubing to drain.
- Drain must slope 1/4" inch per foot (6 mm per 30,4 cm).

## 6. Internal Connections

Air-cooled ice machines – follow steps 6.1 through 6.5.

Water-cooled ice machines – follow steps 6.6 through 6.12.

### 6.1 Ice transport tube

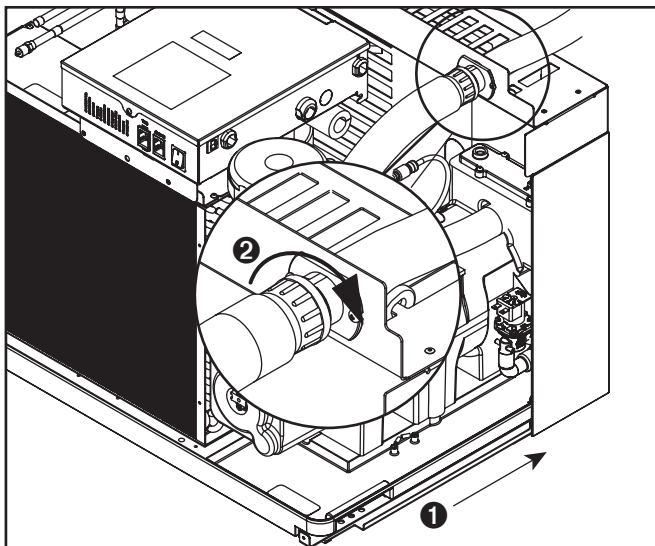

- Slide ice machine into docking assembly *ensuring that drain tube is fully seated on barbed drain fitting* ①.
- Insert ice transport tube all the way into coupling and tighten nut firmly ②.

### 6.3 Power cord

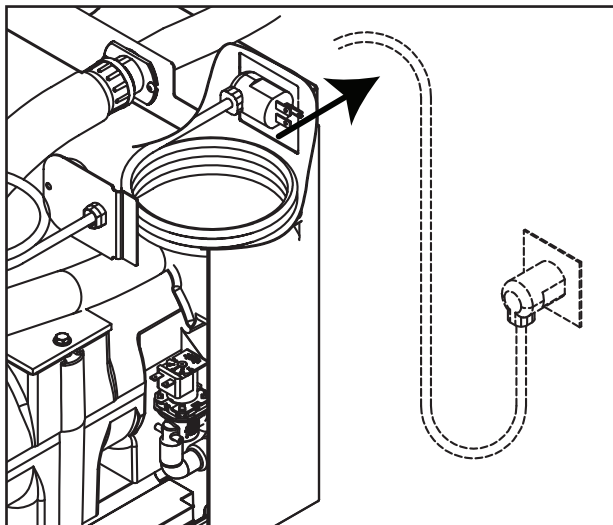

- Remove twist tie.
- Carefully pass cord through opening and plug into wall outlet.
- For H\_E units, install a suitable plug.

### 6.2 Water solenoid, shut-off valve, and potable water line options

#### 6.2.1 If water solenoid is already mounted to evaporator:

1. Insert potable water line into shut-off valve.

#### 6.2.2 If this is an undercounter installation:

1. Mount water solenoid atop evaporator and locate the shut-off valve *inside* the machine. Insert potable water line into shut-off valve.

#### 6.2.3 If water solenoid is not mounted and machine will not be installed undercounter:

1. Mount water solenoid to inside rear (upper right corner) of docking assembly using one screw.
2. Insert potable water line into shut-off valve - locate the shut-off valve *outside* the machine.
3. Insert outgoing line from shut-off valve into push-in connection of water solenoid.

### 6.4 Power cord

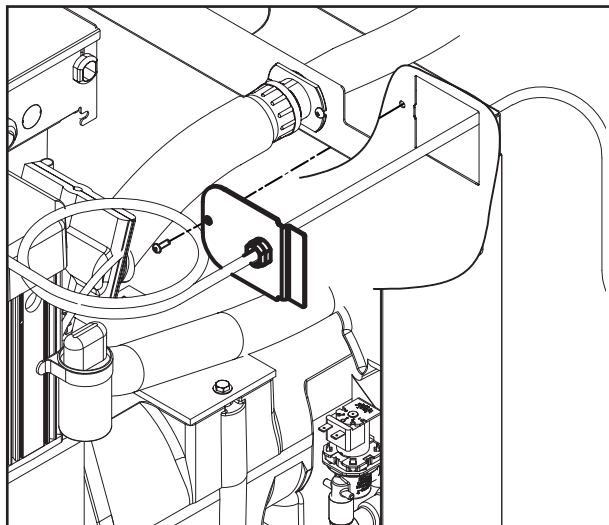

- Position plate into opening and secure with supplied screw.

#### **WARNING!**

*Plate must be securely installed to ensure proper equipment ground.*

## 6.5 TDS switch

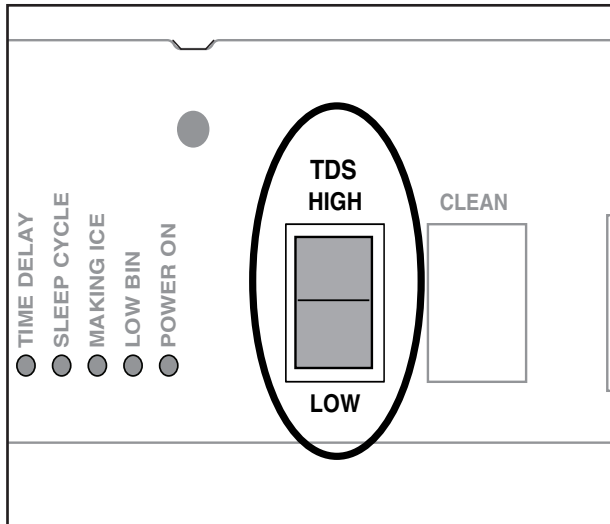

- Set the TDS switch on the electrical box:
  - **HIGH:** for extended service life
  - **LOW:** for low-scale water

## 6.6 Cooling Lines

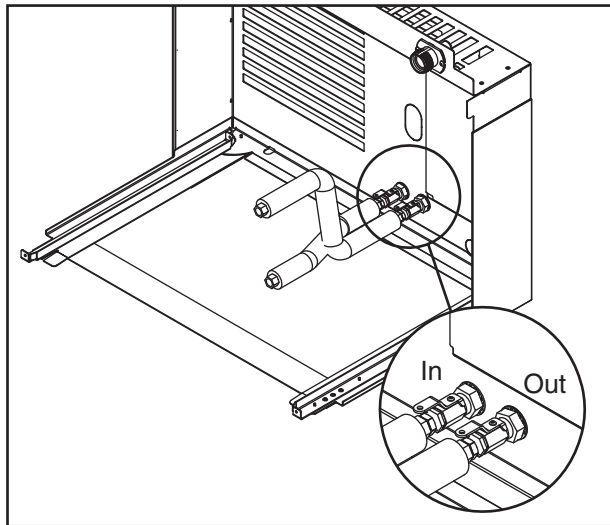

- Install ice machine cooling water lines to docking assembly.

## 6.7 Ice transport tube

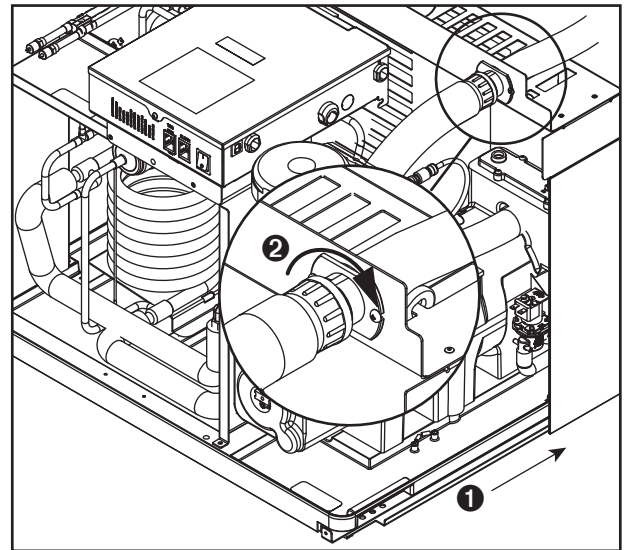

- Slide ice machine into docking assembly *ensuring that drain tube is fully seated on barbed drain fitting ①*.
- Insert ice transport tube into coupling and tighten nut firmly ②.

## 6.8 Water solenoid, shut-off valve, and potable water line options

### 6.9.1 If water solenoid is already mounted to evaporator:

1. Insert potable water line into shut-off valve.

### 6.9.2 If this is an undercounter installation:

1. Mount water solenoid atop evaporator and locate the shut-off valve *inside* the machine. Insert potable water line into shut-off valve.

### 6.9.3 If water solenoid is not mounted and machine will not be installed undercounter:

1. Mount water solenoid to inside rear (upper right corner) of docking assembly using one screw.
2. Insert potable water line into shut-off valve - locate the shut-off valve *outside* the machine.
3. Insert outgoing line from shut-off valve into push-in connection of water solenoid.

## 6.9 Cooling lines and power

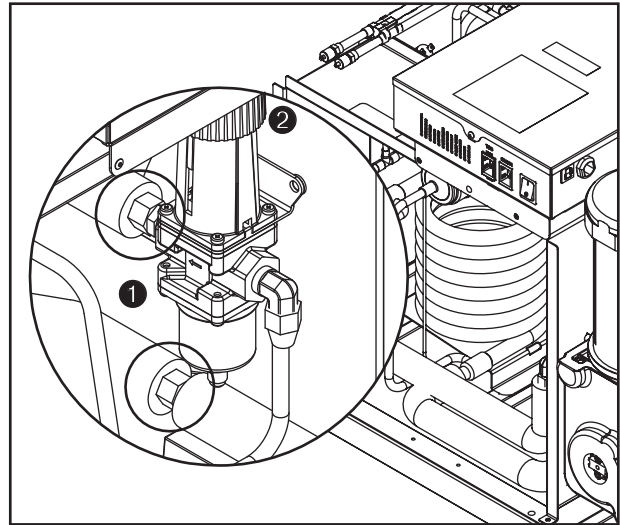

- Connect cooling water lines to ice machine **1**. (Water "Out" connects to water regulator.)
- Water valve is set at the factory. **DO NOT** remove seal or adjust water valve **2**.

## 6.10 Power cord

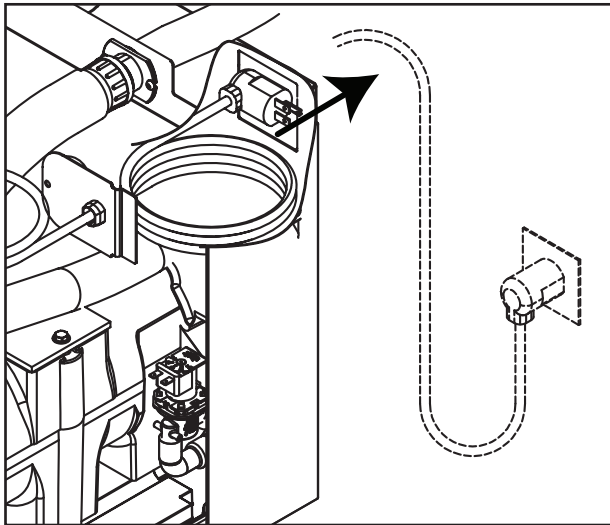

- Remove twist tie.
- Carefully pass cord through opening and plug into wall outlet.
- For H\_E units, install a suitable plug.

## 6.11 Plate

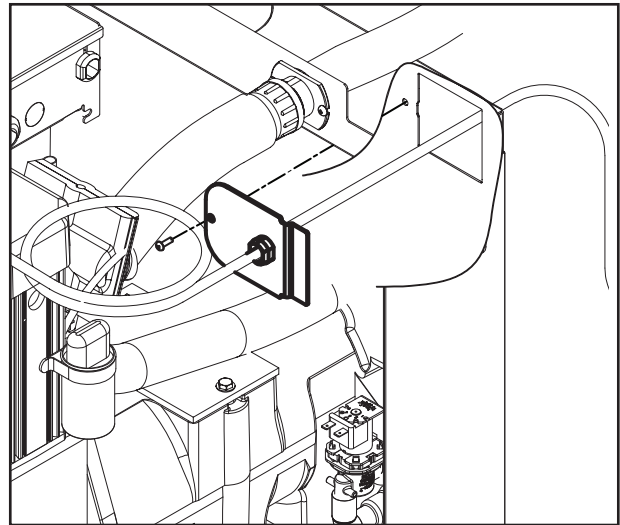

- Position plate into opening and secure with supplied screw.

### **WARNING!**

*Plate must be securely installed to ensure proper equipment ground.*



## 6.12 TDS switch

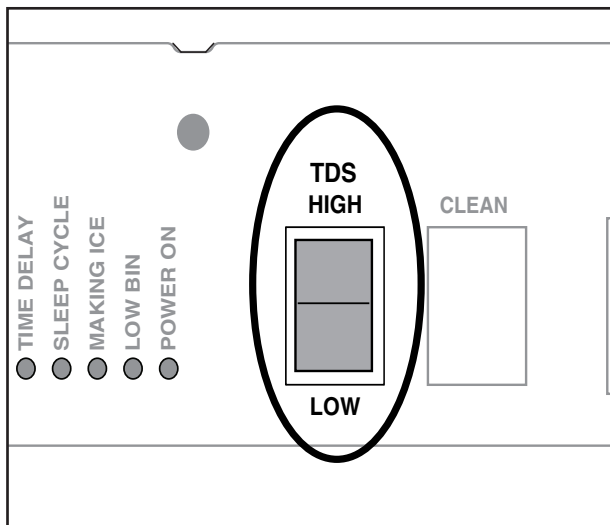

- Set the TDS switch on the electrical box:
  - **HIGH:** for extended service life
  - **LOW:** for low-scale water

## 7. Front Cover

Install front cover to ice machine.

### 7.1 Install cover - undercounter air-cooled application only

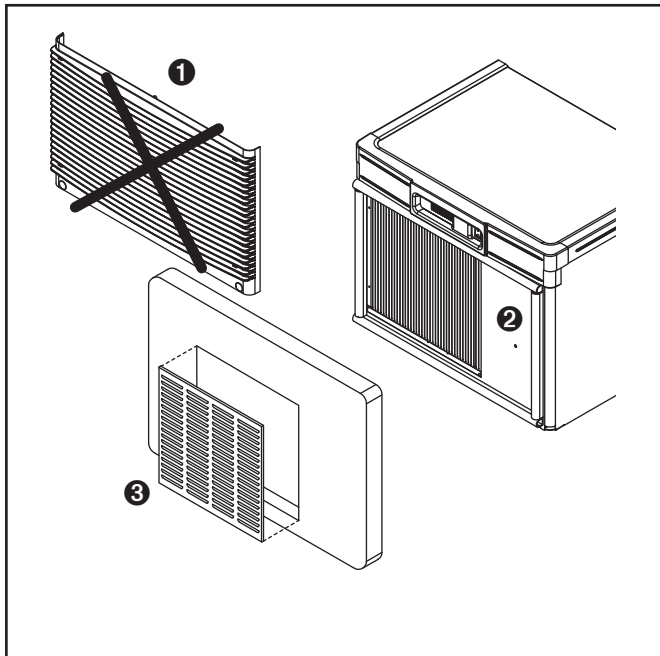

#### NOTICE!

- Keep ventilation openings in the appliance enclosure clear of obstruction. Failure to do so could result in damage to equipment.
  - To ensure proper ventilation (if not using supplied grille) carefully review air circulation specifications in section 4.1
- 
- Remove and discard plastic grille ①.
  - Apply supplied gasket material on flat surface of stainless steel portion of front panel to prevent air recirculation ②.
  - Attach supplied metal grille to opening in counter door (see section 4.1) ③.

#### NOTICE!

- Ice machine **MUST** be sanitized prior to operation!
- Consult Operation and Service Manual provided with ice machine for sanitizing instructions.

### 7.2 Install front cover

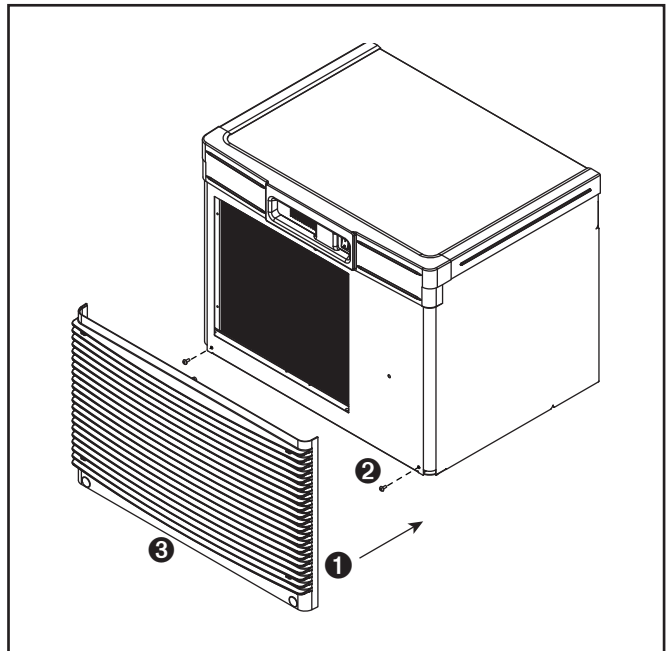

- Slide ice machine cover over machine, ensuring that tabs on back of cover slip under louvers on back of docking assembly ①, then tighten two screws through cover.
- Place front cover on machine ②.
- For air-cooled machines only, install plastic grille ③.

## 8. Dispenser Agitation Adjustment

### 8.1 Agitation adjustments - Cornelius

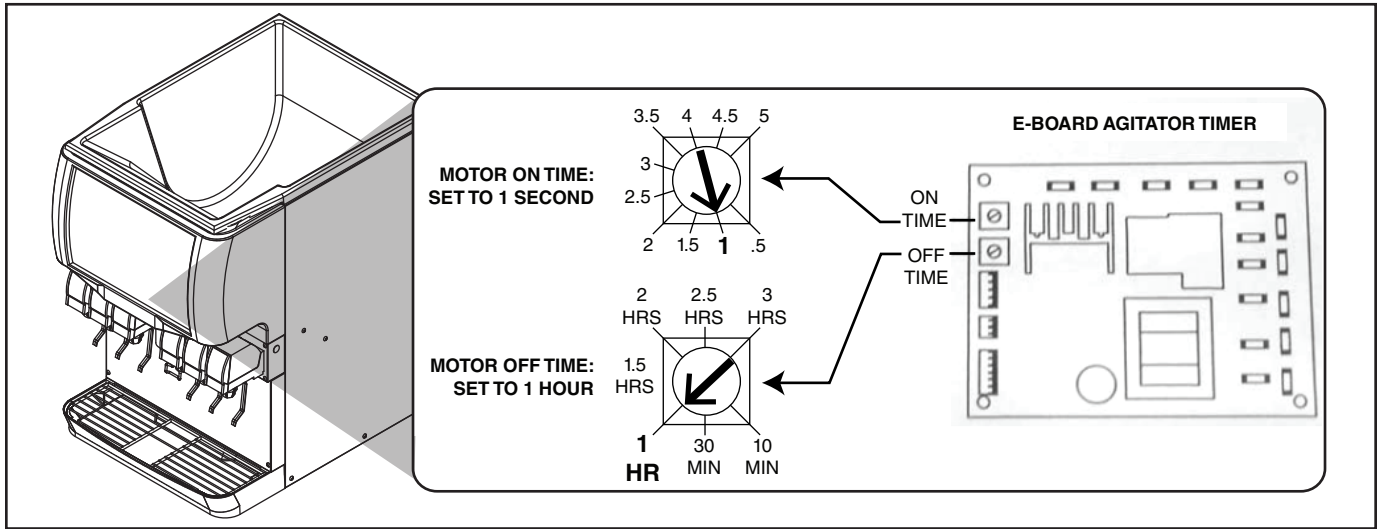

#### Cornelius models ED, DB, DF, IDC and Flavor Fusion

- Adjust the agitation tier located on the Cornelius PC board to 1 second on, 1 hour off.

**Note:** See Cornelius manual or call Cornelius Technical Service at 1-800-238-3600 for more information.

### 8.2 Agitation adjustments – Lancer 4500 Series

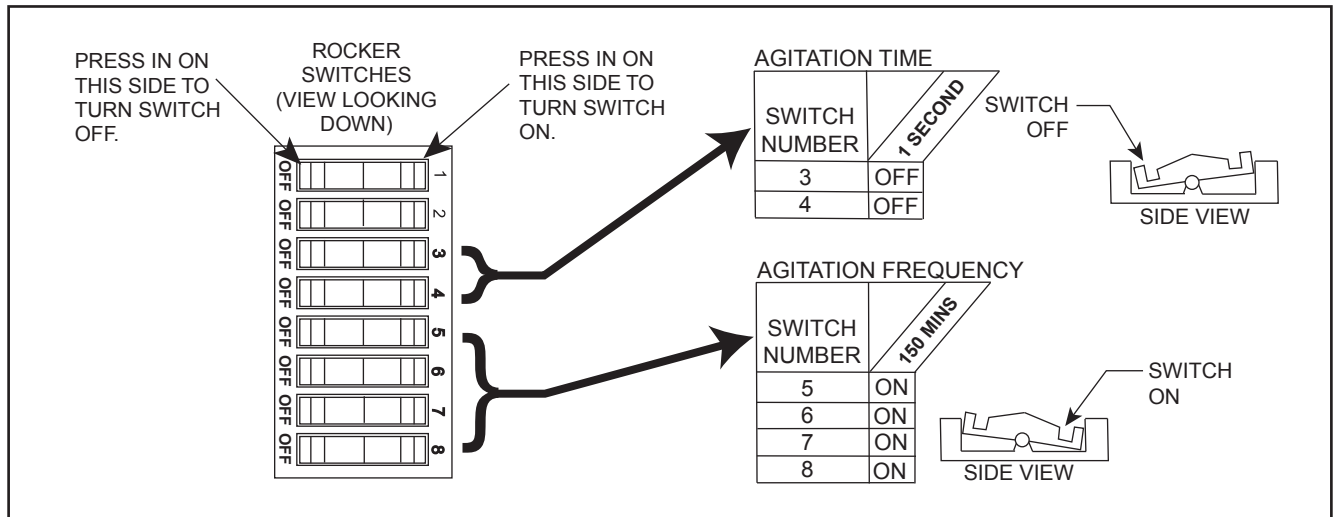

#### Lancer 4500 series only

Adjust the agitation time to 1 second, and the agitation frequency to 150 minutes. See Lancer manual or call Lancer Customer Service at 1-888-846-6729 for more information

### 8.3 Agitation adjustments – Lancer FS Series

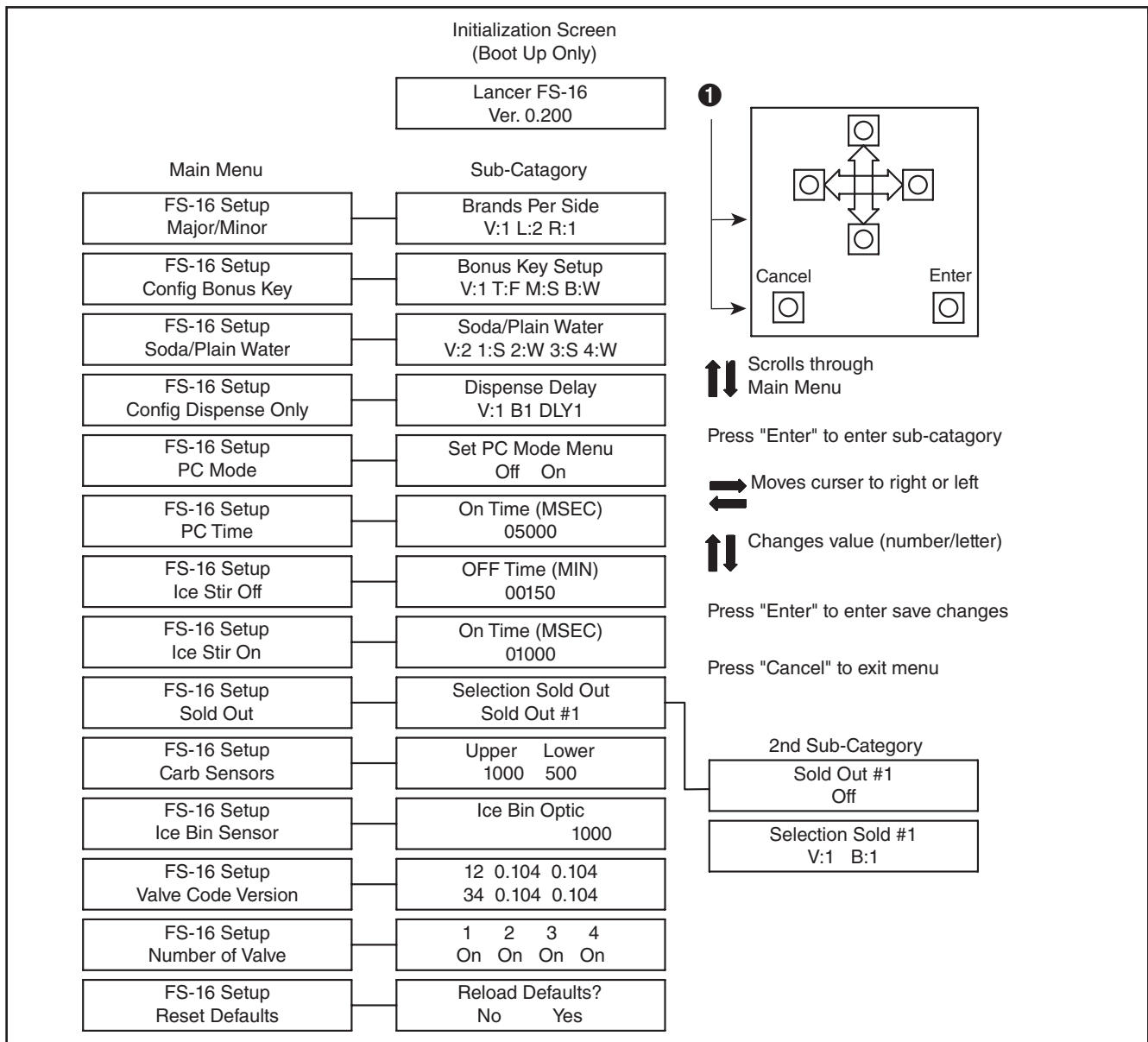

#### Lancer FS series only

- Hold down “cancel” and “left button” to get to hidden menu ❶.
- Type in code 6655.
- Type in 150 minutes of off time and 1000 milliseconds (1 second of time) as the preferred setting.

**Note:** See Lancer manual or call Lancer Customer Service at 1-888-846-6729 for more information.

### 8.4 Agitation adjustments – Servend

No agitation adjustment required.

## 8.5 Dispenser diverter plate overview – Cornelius, ED, DF AND DB SERIES (installation on next page)

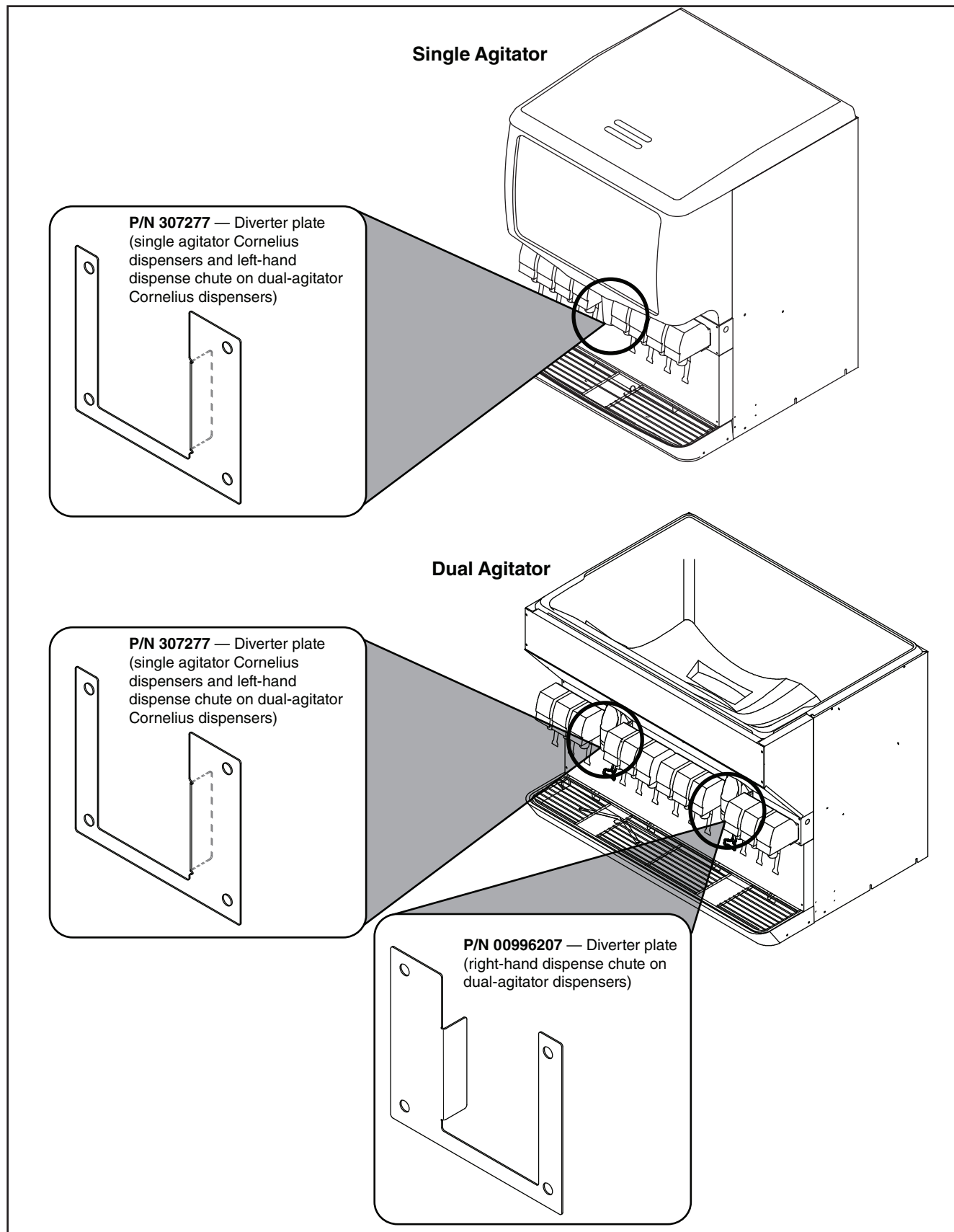

## 8.6 Dispenser diverter plate installation – CORNELIUS, ED, DF AND DB SERIES

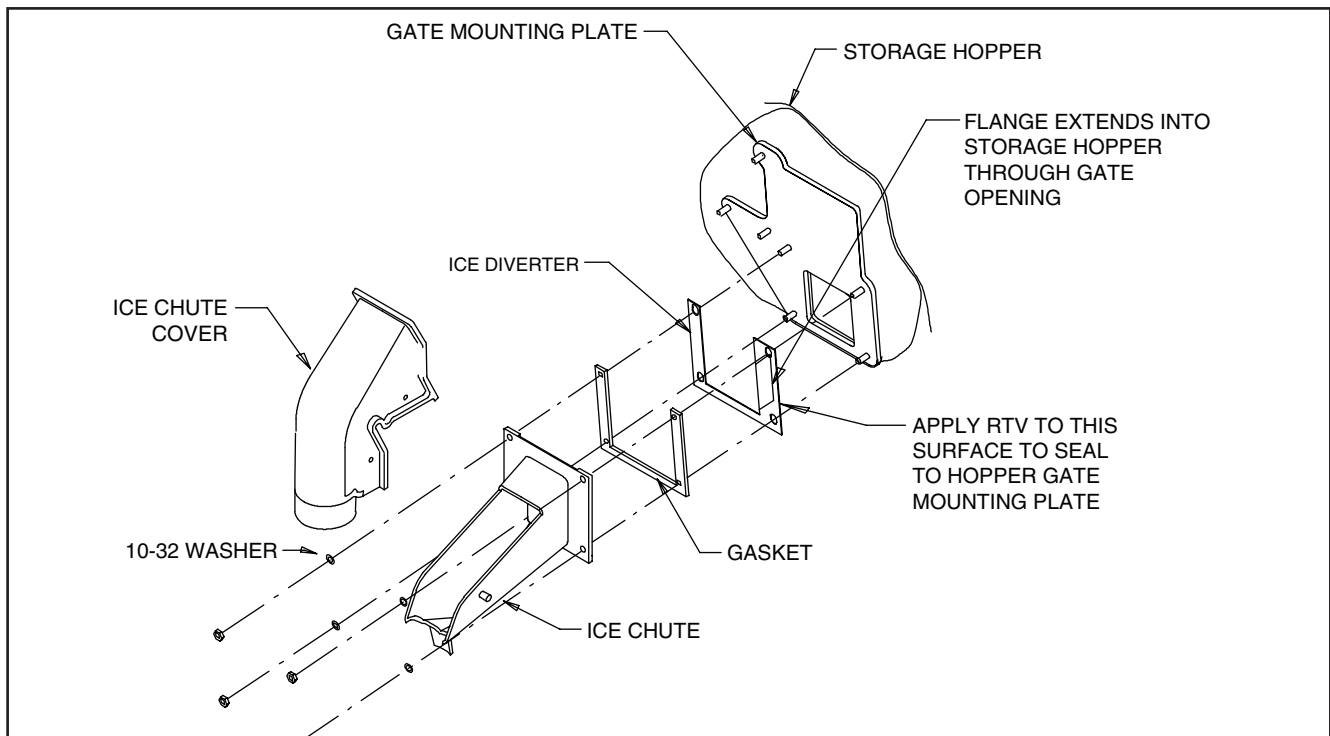

### CORNELIUS ED, DF AND DB series only

These dispensers require the installation of an ice diverter at the dispenser opening:

- Disassemble chute assembly
- Discard factory restrictor plate
- Replace with alternate diverter plate (supplied)

### Cornelius IDC and Flavor Fusion

These dispensers require modifications for compatibility with Chewblet ice. Agitation times must be set to 1 second ON, 1 hour OFF and the ice restrictor plate must be adjusted to the fully open position. See your beverage supplier for these modifications.

**Note:** IDC and Flavor Fusion must be nugget-ready. Please contact beverage supplier for installation of ice slide.

## 9. RIDE model ice machine start up procedure

---

The start-up procedure below is intended to ensure that ice machine is operating properly after installation has been made. Check each item listed and call factory immediately for assistance if you experience problems with unit.

### NOTICE!

- Ice machine **MUST** be sanitized prior to operation!
- Consult Operation and Service Manual provided with ice machine for sanitizing instructions.

### 9.1 Before turning on power

1. Sanitize ice bin.
2. Turn on water to ice machine and check for leaks.

### 9.2 After turning on power

1. Turn on power switch and immediately press Clean switch to sanitize ice machine. At beginning of sanitizing process, ice machine will purge all water. Check internal and external drain connections for leaks.
2. After sanitizing process, ice machine will start. Confirm that gearmotor, fan motor and compressor start immediately.
3. Check that ice begins to enter dispenser bin area within approximately 10 minutes.

Maestro, Vision, Ice Manager, Horizon, Horizon Elite are trademarks of Follett Products, LLC.  
Chewblet, RIDE, Follett are registered trademarks of Follett Products, LLC.

---

**FOLLETT**<sup>®</sup> 801 Church Lane • Easton, PA 18040, USA  
Toll free (877) 612-5086 • +1 (610) 252-7301  
[www.follettice.com](http://www.follettice.com)

01113224R07  
© Follett Products, LLC 11/24