

D710, E710A Horizon Elite™ Ice Machines (Self-contained)

User Guide After Serial Number R03746

Please visit www.follettice.com/technicaldocuments
for the Operation and Service manual for your unit.

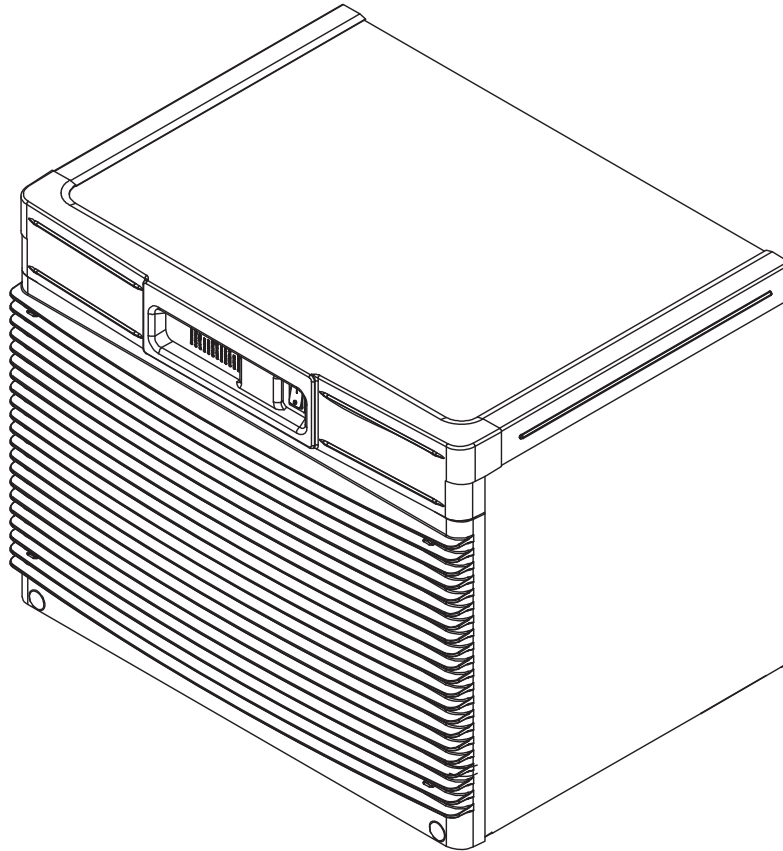

Welcome to Follett

Follett equipment enjoys a well-deserved reputation for excellent performance, long-term reliability and outstanding after-the-sale support. To ensure that this equipment delivers that same degree of service, review this guide carefully before you begin your installation.

Should you need technical help, please call our Technical Service group at (877) 612-5086 or (610) 252-7301.

Please have your model number, serial number and complete and detailed explanation of the problem when contacting Technical Service.

Getting Started

After uncrating and removing all packing material, inspect the equipment for concealed shipping damage. All freight is to be inspected upon delivery. If visible signs of damage exist, please refuse delivery or sign your delivery receipt "damaged." Follett Customer Service must be notified within 48 hours. Wherever possible, please include detailed photos of the damage with the original packaging so that we may start the freight claim process.



CAUTION!

- Installation and service must be performed in accordance with all federal, state and local laws. It is the responsibility of the technician to ensure that these requirements are met.
- To reduce risk of shock, disconnect power before servicing.
- A qualified person shall provide a readily accessible disconnect device incorporated into the fixed wiring.
- This appliance should be permanently connected by a qualified person in accordance with applicable codes.
- Connect to potable water supply only.
- Follett recommends a Follett water filter system be installed in the ice machine inlet water line (standard capacity, high capacity, carbonless high capacity).
- Prior to operation clean the dispenser in accordance with instructions found in this manual.
- This appliance is designed for commercial use.
- Warranty does not cover exterior or outside installations.
- **WARNING!** To avoid a hazard due to instability of the appliance, it must be fixed in accordance with the instructions.
- Do not tilt unit further than 30° off vertical during uncrating or installation.
- Dispenser bin area contains mechanical, moving parts. Keep hands and arms clear of this area at all times. If access to this area is required, power to unit must be disconnected first.
- This appliance is not suitable for installation in an area where a water jet could be used.
- This appliance must not be cleaned by a water jet.
- User maintenance should not be done by children.
- Do not block air intake or exhaust.
- If the supply cord is damaged, it must be replaced by the manufacturer, its service agent or similarly qualified persons in order to avoid a hazard.
- This appliance can be used by children aged 8 years and above and persons with reduced physical, sensory, or mental capabilities, or lack of experience and knowledge if they have been given supervision or instruction concerning use of the appliance in a safe way and understand the hazards involved. Children should be supervised to ensure that they do not play with the appliance.
- Ice is slippery. Maintain counters and floors around dispenser in a clean and ice-free condition.
- Ice is food. Follow recommended cleaning instructions to maintain cleanliness of delivered ice.

Specifications

Electrical

Each ice machine requires its own separate circuit with electrical disconnect within 10 ft (3 m).
Equipment ground required.

Standard electrical:

- 115 V/60/1 (6 ft (2 m) NEMA 5-15 cord and plug provided)
- 230/50/1 (6 ft (2 m) cord) requires dedicated 15A circuit
- Amperage: 120 V @ 11.3A, 230 V @ 6A; dedicated 15A circuit required

Plumbing



WARNING

This equipment to be installed with adequate backflow protection to comply with applicable federal, state, and local codes.

- 3/8" OD push-in water inlet - 3/8" OD tubing required
- 3/4" MPT flush drain, 3/8" chassis drain

Notes:

- Water shut-off recommended within 10 ft (3 m).
- Follett does not recommend the use of water softeners or bowl scale inhibitors.

Drain plumbing

- 3/4" MPT drain connection at the rear of the machine.
- Drain must slope 1/4" per foot (6 mm per 30,4 cm).
- Drain line should not be shared with any other piece of equipment.
- Drain line cannot be reduced to a size smaller than 1".
- Drain should be piped without a vent.

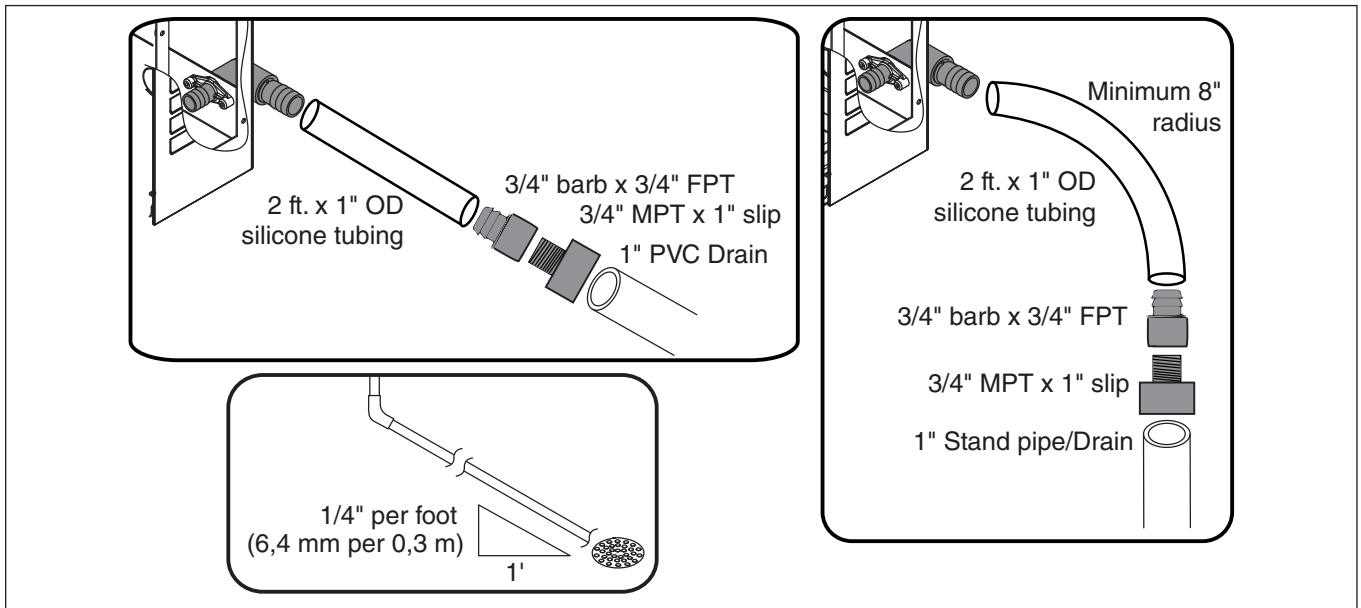

Chassis drain plumbing

- Plug must be removed from John Guest fitting.
- Route 3/8" drain tubing through knockout in back of docking station and insert fully into John Guest fitting connection at the rear of the machine chassis. Route other end of 3/8" drain tubing to drain.
- Drain must slope 1/4" per foot (6 mm per 30,4 cm).

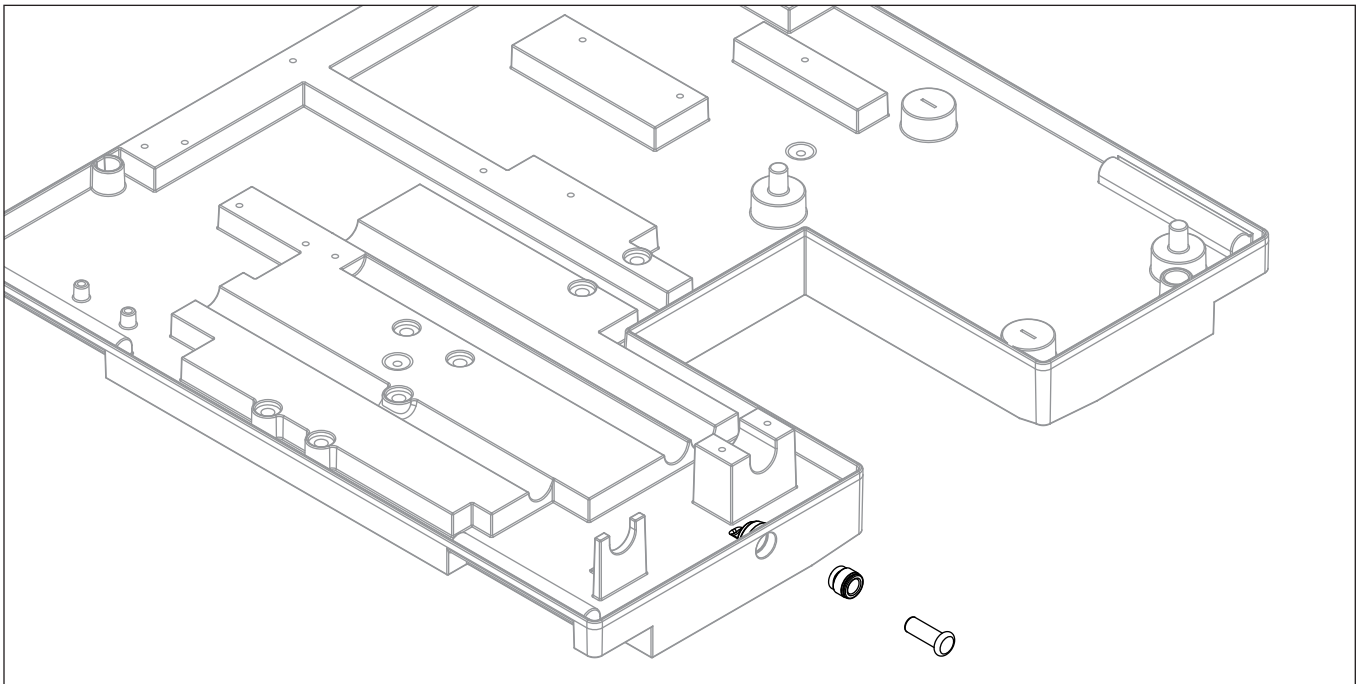

Ambient

Air temperature	100 F/38 C max.	50 F/10 C min.
Water temperature	90 F/32 C max.	45 F/7 C min.
Water pressure – potable	70 psi max. (483 kPa)	10 psi min. (89 kPa)

Heat rejection

	710
Air-cooled	8,500 BTU/hr

Ice production

Horizon Elite 710 series, air-cooled 60 Hz

Inlet water temperature F (C)	Ambient air temperature F (C)					lb (kg) production in 24 hr
	60 (16)	70 (21)	80 (27)	90 (32)	100 (38)	
50 (10)	787 (357)	759 (345)	705 (320)	639 (290)	603 (274)	
60 (16)	750 (341)	702 (319)	666 (302)	624 (283)	570 (259)	
70 (21)	707 (321)	681 (309)	636 (289)	586 (266)	542 (246)	
80 (27)	677 (307)	629 (286)	611 (277)	559 (254)	518 (235)	
90 (32)	642 (291)	600 (272)	580 (263)	539 (245)	497 (226)	

Horizon Elite 710 series, air-cooled 50 Hz

Inlet water temperature F (C)	Ambient air temperature F (C)					lb (kg) production in 24 hr
	60 (16)	70 (21)	80 (27)	90 (32)	100 (38)	
50 (10)	664 (301)	617 (280)	576 (261)	538 (244)	500 (227)	
60 (16)	645 (293)	601 (272)	560 (254)	521 (236)	481 (218)	
70 (21)	626 (284)	582 (264)	544 (247)	506 (229)	464 (210)	
80 (27)	588 (267)	544 (247)	512 (232)	481 (218)	389 (176)	
90 (32)	557 (252)	519 (235)	487 (221)	455 (207)	328 (149)	

Weight

Shipping	190 lb (86 kg)
Net	180 lb (82 kg)

Dimensions and clearances

- Entire front of ice machine must be clear of obstructions/connections to allow removal.
- 1" (26 mm) clearance above ice machine for service.
- 1" (26 mm) minimum clearance on sides.
- The intake and exhaust air grilles must provide at least 250 sq in (1615 sq cm) of open area.
- Air-cooled ice machines – 18" (458 mm) minimum clearance between discharge and air intake-grilles.

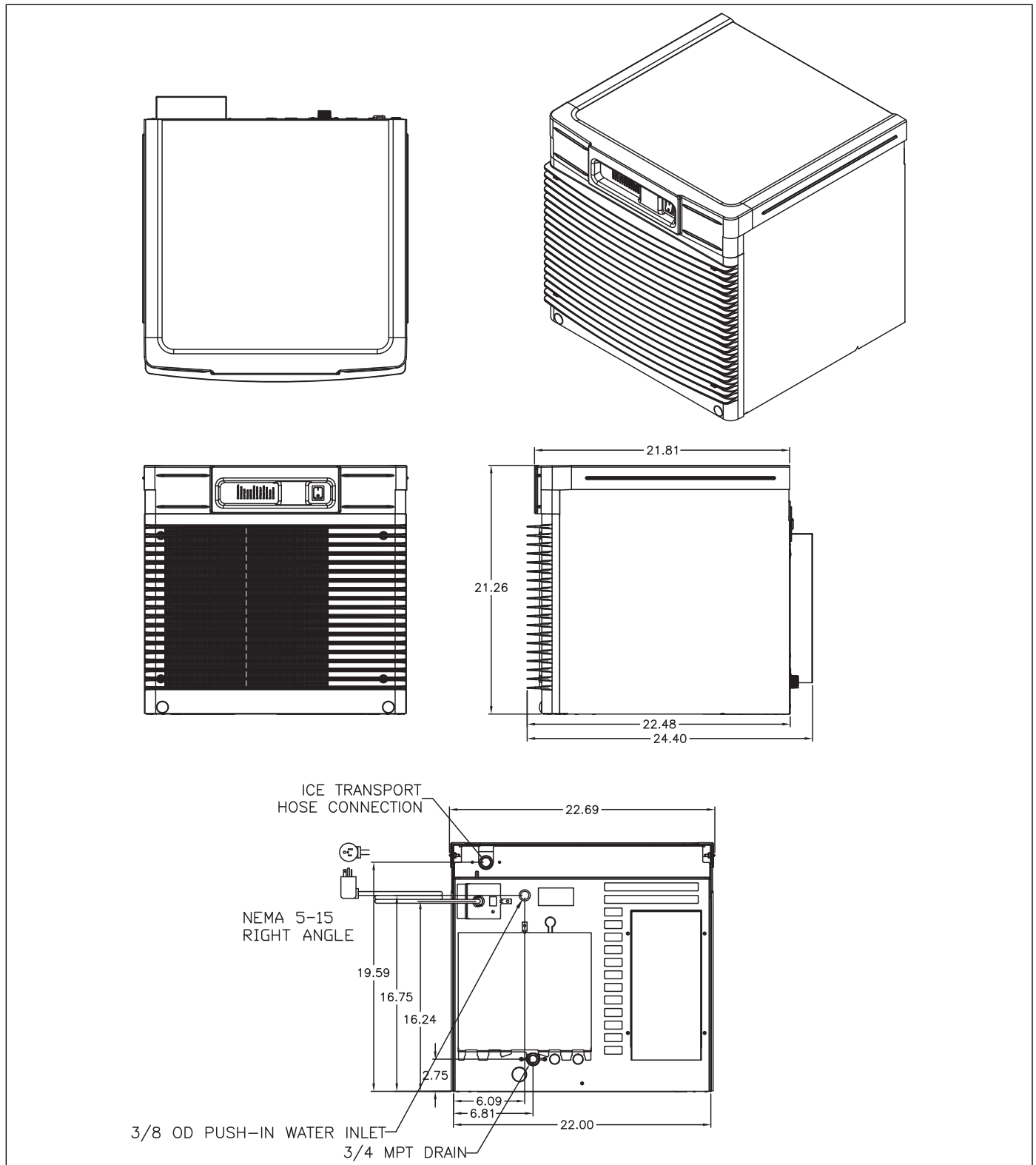

* Plug supplied by user on 230 V units.

Operation

Cleaning/sanitizing and preventive maintenance (all models)

Note: Do not use bleach to sanitize or clean the icemaker.

Preventive maintenance

Periodic cleaning of Follett's icemaker system is required to ensure peak performance and delivery of clean, sanitary ice. The recommended cleaning procedures that follow should be performed at least as frequently as recommended, and more often if environmental conditions dictate.

Cleaning of the condenser can usually be performed by facility personnel. Cleaning of the icemaker system, in most cases, should be performed by your facility's maintenance staff or a Follett authorized service agent. Regardless of who performs the cleaning, it is the operator's responsibility to see that this cleaning is performed according to the schedule below. Service problems resulting from lack of preventive maintenance will not be covered under the Follett warranty.

Weekly exterior care

The exterior may be cleaned with a stainless cleaner such as 3M Stainless Steel Cleaner and Polish or equivalent.

Monthly condenser cleaning (air-cooled icemaker only)

1. Use a vacuum cleaner or stiff brush to carefully clean condenser coils of air-cooled icemakers to ensure optimal performance.
2. When reinstalling counter panels in front of remote icemakers, be sure that ventilation louvers line up with condenser air duct.

Semi-annual evaporator cleaning (every 6 months)

WARNING

- Wear rubber gloves and safety goggles (and/or face shield) when handling ice machine cleaner or sanitizer.

CAUTION

- Use only Follett approved SafeCLEAN Plus™ cleaning solution.
- DO NOT USE BLEACH.
- It is a violation of federal law to use these solutions in a manner inconsistent with their labeling.
- Read and understand all labels printed on packaging before use.

Note: Complete procedure for cleaning and sanitizing MUST be followed. Ice must be collected for 10 minutes before putting ice machine back into service.

1. Note position of TDS switch. Set to HIGH for duration of cleaning. Press the CLEAN button. The machine will fill and drain three times (**approximately 5 minutes**). The auger will run for a short time and then stop. Wait for the LOW WATER light to come on.

Fig. 1

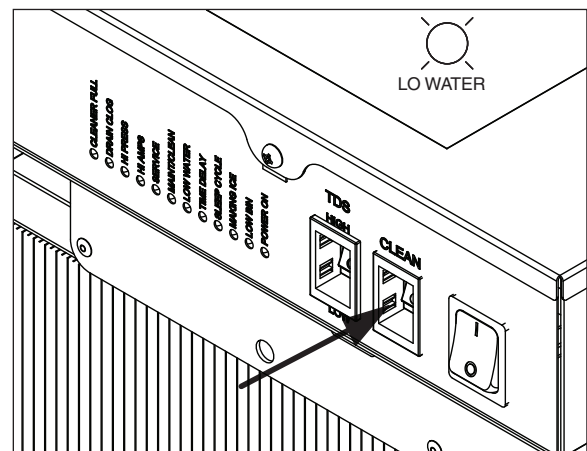

2. Follow the directions on the SafeCLEAN Plus packaging to mix 1 gal. (3.8 L) of Follett SafeCLEAN Plus solution. Use 100 F (38 C) water.
3. Using a 1 quart (1 L) container, slowly fill cleaning cup until CLEANER FULL light comes on and cleaner just begins to flow from the vent tube.
4. Place two SaniSponge™ cleaning sponges in remaining sanitizing and cleaning solution and retain for Step 9.

Note: Do not use bleach to sanitize or clean the icemaker.

Fig. 2

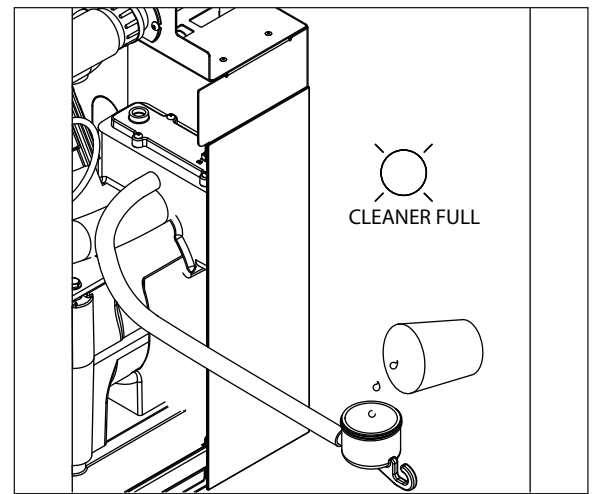

5. Replace cover on cleaner cup. Machine will clean, then flush 3 times in approximately 15 minutes. Wait until machine restarts.

Fig. 3

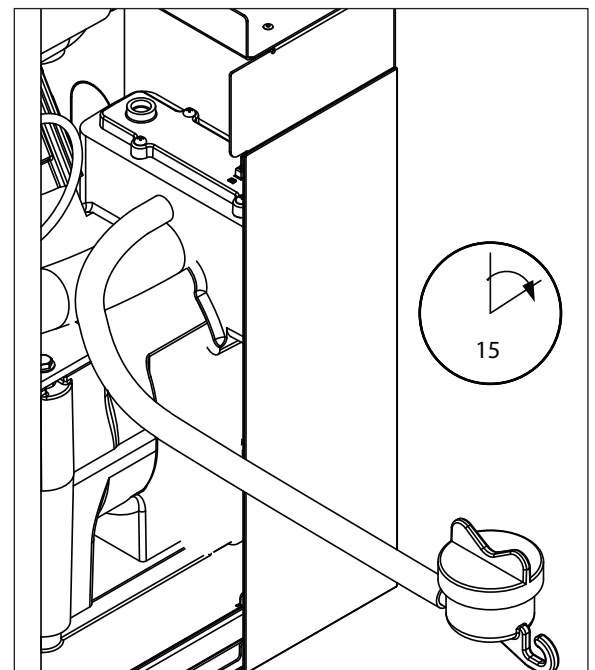

6. To clean/sanitize ice transport tube – Press power switch OFF

Fig. 4

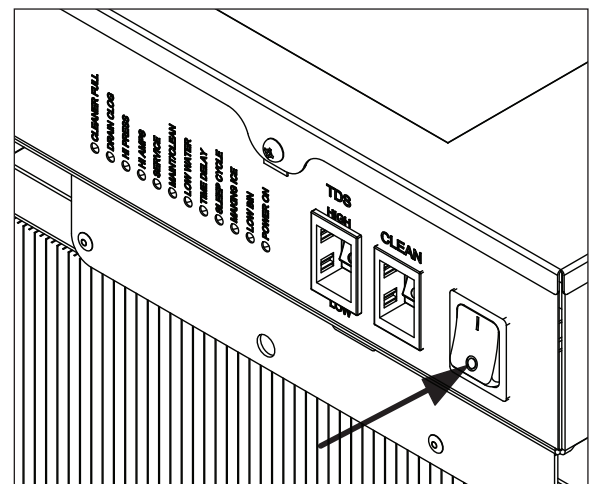

7. Disconnect coupling as shown.

Fig. 5

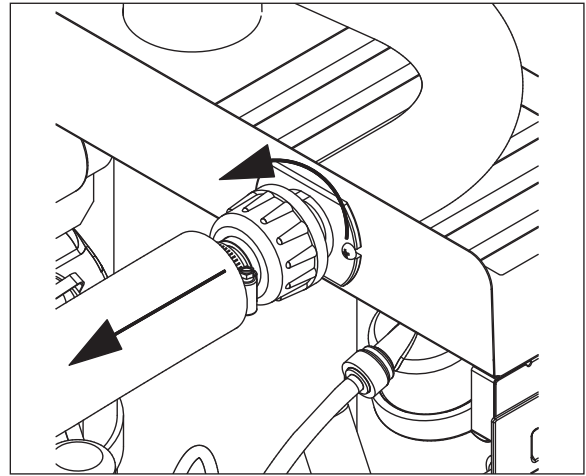

8. Using disposable foodservice grade gloves, insert both SaniSponge cleaning sponges saturated in SafeClean Plus (from Step 4).
9. Push both SaniSponge cleaning sponges down ice transport tube with supplied pusher tube.

Fig. 6

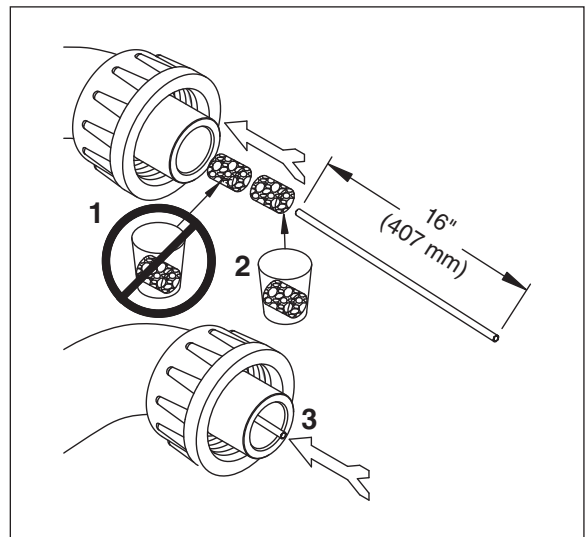

10. Remove and discard 16" (407 mm) pusher tube.

Fig. 7

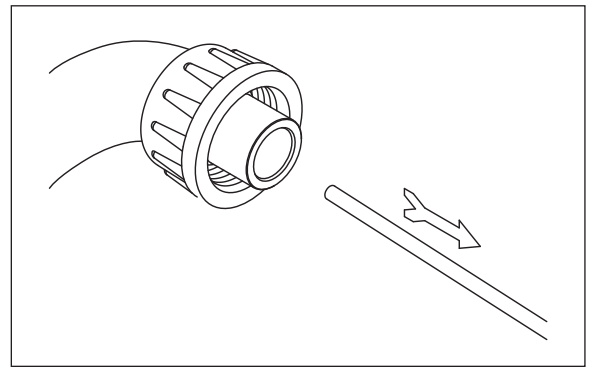

11. Reconnect coupling. Press power switch ON. Ice pushes SaniSponge cleaning sponges through ice transport tube.

Fig. 8

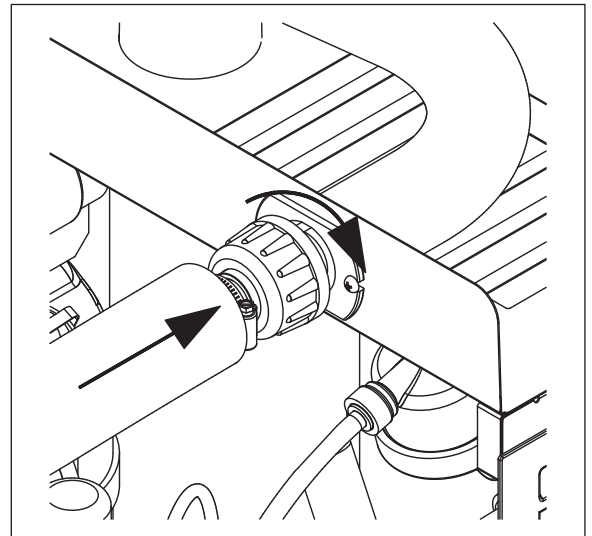

12. Place a sanitary (2 gal. or larger) container in bin or dispenser to collect SaniSponge cleaning sponges and ice for 10 minutes after the Sani-Sponges come out.

13. Discard ice and Sani-Sponges. Return TDS switch to the original position.

Fig. 9

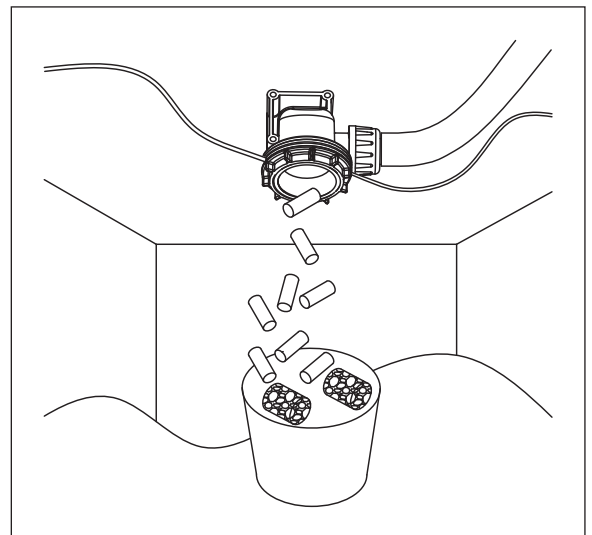

Wiring diagram

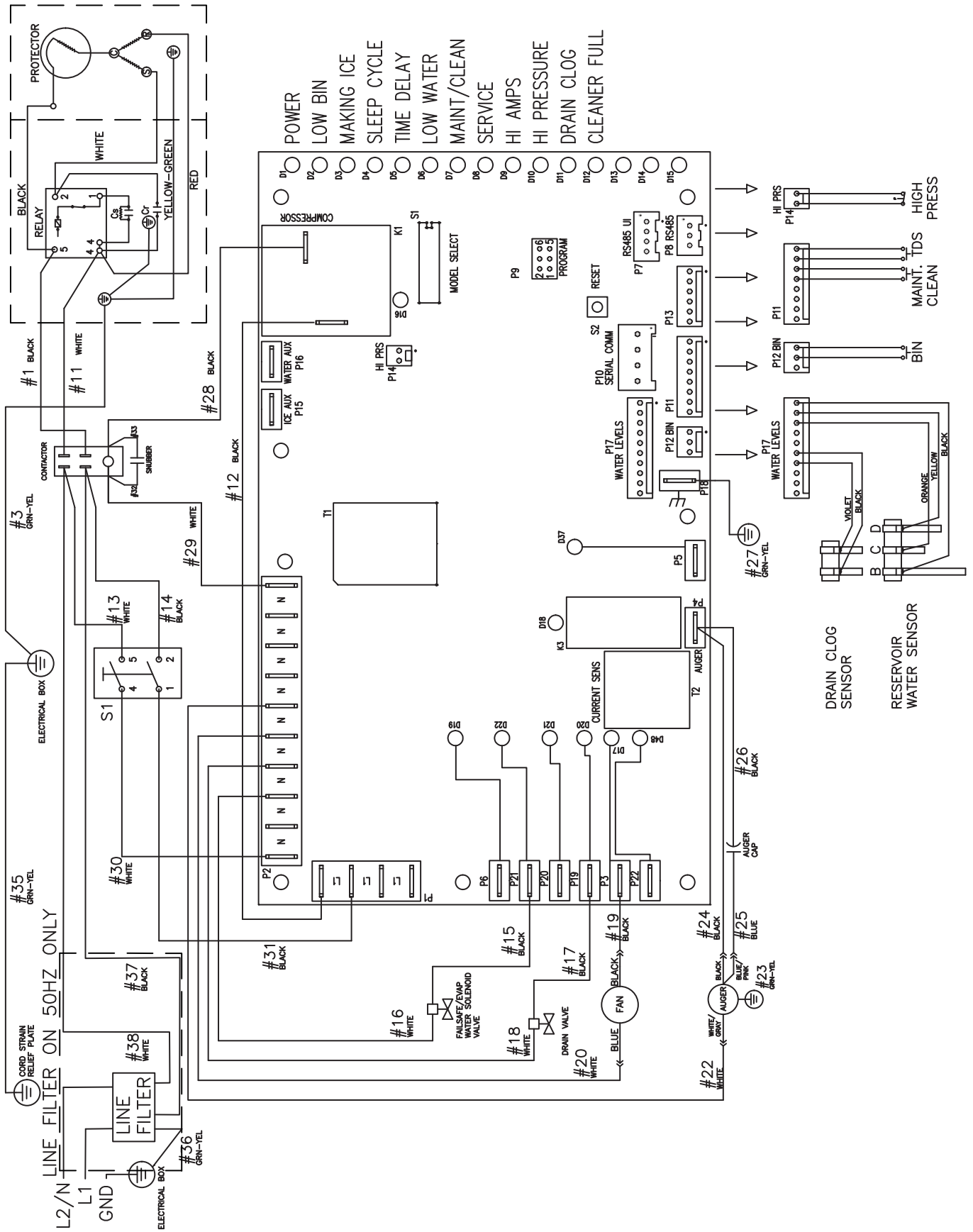

Compressor data

	120 V	230 V
Compressor current draw at 90 F/32.2 C	7.8A	1.9A
Locked rotor amps	93.0A	21.0A
Compressor start winding	2.23Ω	11Ω
Compressor run winding	0.32Ω	5.15Ω

Gearmotor data

Gearmotor current 1.2A @ 120 V, 0.8 @ 230 V

Gearmotor torque-out (high amp) trip point: 1.8A @ 120 V, 1.2 @ 230 V

Resistance of windings

115 vac gearmotor (Brother):

Gray to black: 15.5Ω

Blue to gray: 15.5Ω

Blue to black: 31Ω

230 vac gearmotor:

White to black: 62Ω

White to tan: 62Ω

Tan to black: 124Ω

Fan motor data

Fan motor current 0.2A @ 120 V and 230 V

Refrigeration system

Refrigerant pressure data

Air-cooled condensers (air)	60 F/16 C	70 F/21 C	80 F/27 C	90 F/32 C	100 F/38 C
120 V Pressure (psig) discharge/suction	190/32	225/34	258/36	292/39	325/41
230 V Pressure (psig) discharge/suction	180/17	195/19	225/22	256/24	310/26

Refrigeration charge

All service on refrigeration systems must be performed in accordance with all federal, state and local laws. It is the responsibility of the technician to ensure that these requirements are met. Recharging ice machine to other than factory specifications will void the warranty.

Ice machine charge specifications

Model	Charge	Refrigerant type
710A (air-cooled)	21 oz (595 g)	R404A
E710A (air-cooled)	24 oz (680 g)	R449A

Refrigeration system diagram

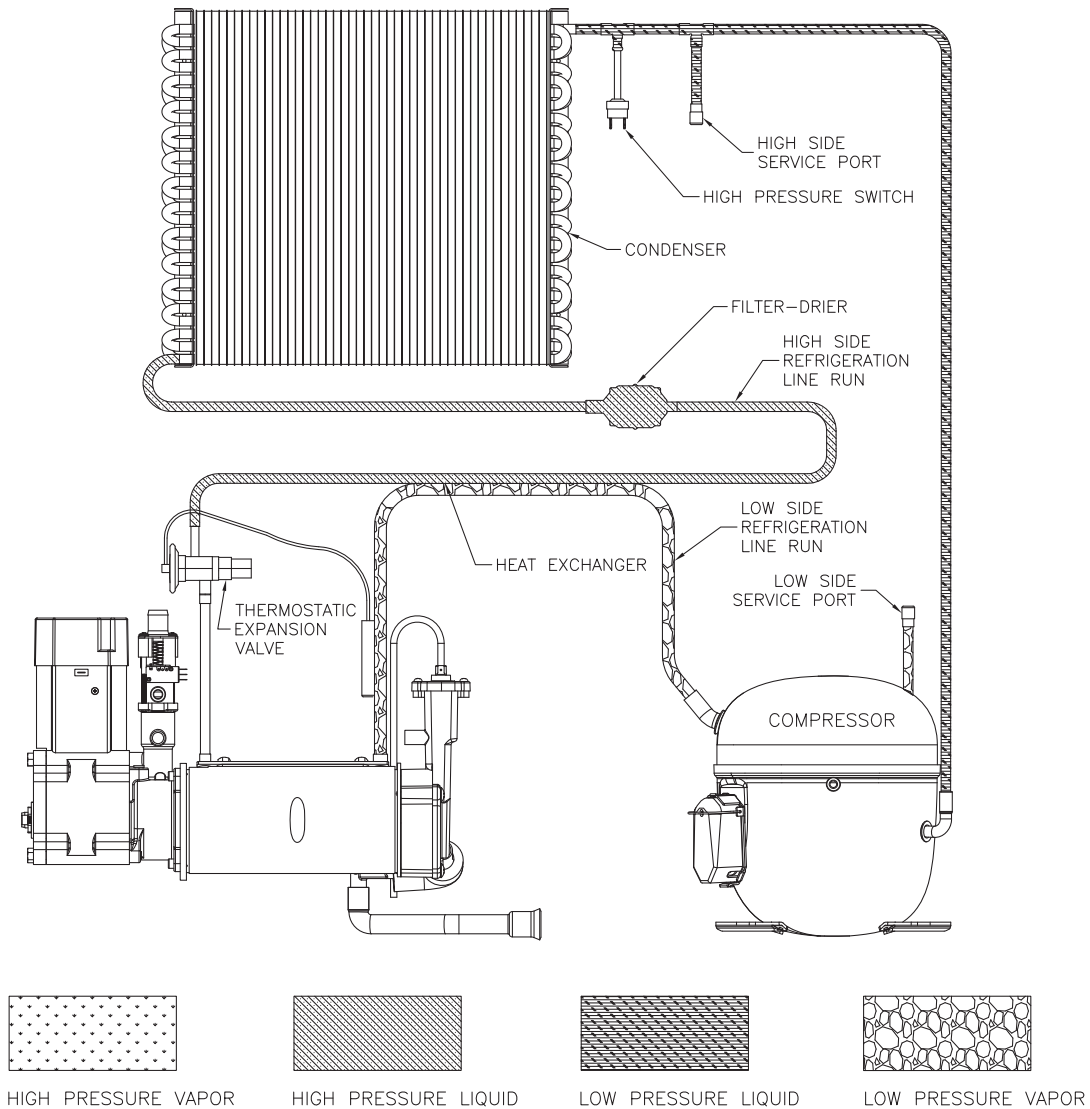

Evacuation

Evacuate the system to a level of 500 microns. When the 500 micron level is reached, close all valves. Allow the system to sit for approximately 20 minutes. During this period the system pressure should not rise. If the system pressure rises and stabilizes there is moisture in the system and further evacuation is needed. If the pressure continues to rise check the system for leaks.

Ambients	Minimum	Maximum
Air temperature ¹	50 F/10 C	100 F/37.8 C
Water temperature ²	45 F/7 C	90 F/32.2 C

¹Ambient air temperature is measured at the air-cooled condenser coil inlet.

²Ambient water temperature is measured at the water feed valve inlet.

Ice capacity test

Ice machine production capacity can only be determined by weighing ice produced in a specific time period.

1. Replace all panels on ice machine.
2. Run ice machine for at least 15 minutes.
3. Move TDS switch to LOW.
4. Press the reset button on the board.

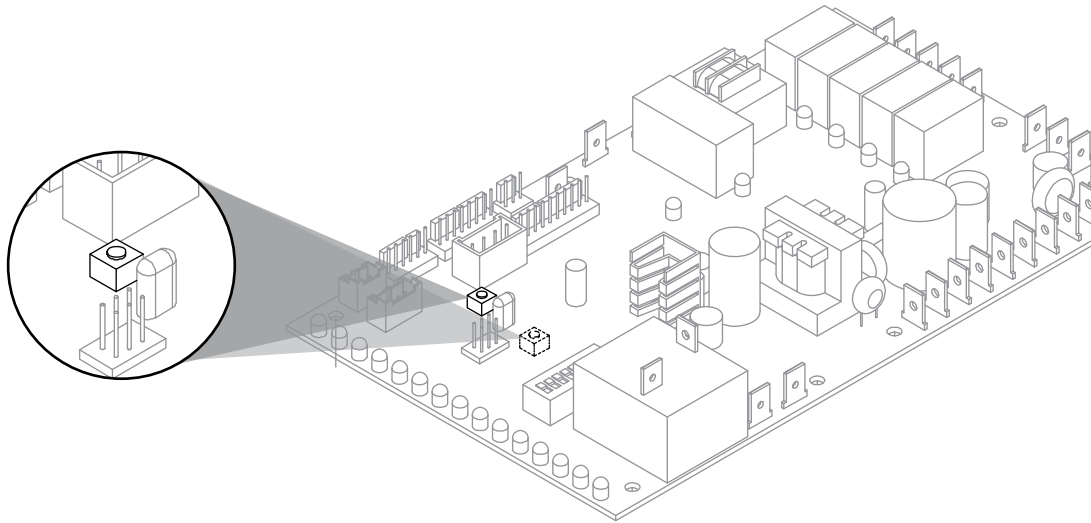

5. Weigh and record weight of container used to catch ice.
6. Catch ice for 15 minutes.
7. Weigh harvested ice and record total weight.
8. Subtract weight of container from total weight.
9. Convert fractions of pounds to decimal equivalents (ex. 6 lbs 8 oz = 6.5 lbs).
10. Calculate production using following formula:

$$\frac{1440 \text{ min.} \times \text{wt. of ice produced}}{\text{Total test time in minutes}} = \text{Production capacity/24 hr.}$$

11. Calculated amount per 24 hours should be checked against rated capacity for same ambient and water temperatures in Ice Production Tables.
12. Move TDS switch to the HI TDS position.

Troubleshooting

Please see "Service" section for a description of each function.

Ice machine disposition	Possible causes	Corrective action
Legend: ● ON ○ OFF ◐ ON or OFF ✖ FLASHING		
1. Ice machine is in running condition but not making ice. CLEANER FULL ○ DRAIN CLOG ○ HI PRESS ○ HI AMPS ○ SERVICE ○ MAINT/CLEAN ○ LOW WATER ○ TIME DELAY ○ NOT USED ○ MAKING ICE ● LOW BIN ● POWER ON ✖	1. Defective compressor. 2. Defective start relay. 3. Defective start capacitor. 4. Defective run capacitor. 5. Defective main contactor. 6. No output from PC board.	1. Replace compressor. 2. Replace start relay. 3. Replace start capacitor. 4. Replace run capacitor. 5. Replace main contactor. 6. Replace PC board.
2. Machine in TIME DELAY without full bin. CLEANER FULL ○ DRAIN CLOG ○ HI PRESS ○ HI AMPS ○ SERVICE ○ MAINT/CLEAN ○ LOW WATER ○ TIME DELAY ◐ NOT USED ○ MAKING ICE ○ LOW BIN ○ POWER ON ✖	1. Ice jamming due to improperly installed transport tube causing a false shuttle. 2. Shuttle stuck in up position. 3. Damaged or improperly installed thermostat (open). 4. Transport tube backed-out of coupling.	1. Correct transport tube routing. 2. Repair or replace shuttle mechanism. 3. Replace or reposition thermostat. 4. Correct coupling installation.
3. Ice machine is not making ice. HI AMPS. CLEANER FULL ○ DRAIN CLOG ○ HI PRESS ○ HI AMPS ● SERVICE ○ MAINT/CLEAN ○ LOW WATER ○ TIME DELAY ○ NOT USED ○ MAKING ICE ○ LOW BIN ○ POWER ON ✖	1. Poor water quality causing ice to jam auger. 2. Damaged shuttle mechanism. 3. Intermittent drive output from PC board. Evaporator will freeze causing a HI AMPS error. 4. Gearmotor is unplugged.	1. Clean ice machine. Increase flushing frequency. Position TDS switch to High TDS setting. 2. Replace or repair shuttle mechanism. 3. Replace PC board. 4. Plug in gearmotor.
4. Ice machine is not making ice. HI PRESSURE. CLEANER FULL ○ DRAIN CLOG ○ HI PRESS ● HI AMPS ○ SERVICE ○ MAINT/CLEAN ○ LOW WATER ○ TIME DELAY ○ NOT USED ○ MAKING ICE ○ LOW BIN ○ POWER ON ✖	1. High ambient temperatures >100 F (38 C). 2. Poor ventilation or air recirculation. 3. Clogged condenser (air-cooled). 4. No water flow through condenser (water-cooled). 5. Fan not working properly. No air flow. <ul style="list-style-type: none"> • Blocked fan blades • No fan output from PC board • Faulty fan motor 	1. Air condition area to below 100 F (38 C). 2. Reposition ice machine or properly ventilate. Prevent ice machine exhaust from recirculating. 3. Clean condenser grille (air-cooled). 4. Restore water flow to condenser. 5. Correct air flow. <ul style="list-style-type: none"> • Remove any blockage from fan blades • Replace PC board • Replace fan motor
5. Ice machine is not making ice. SERVICE. CLEANER FULL ○ DRAIN CLOG ○ HI PRESS ○ HI AMPS ○ SERVICE ● MAINT/CLEAN ○ LOW WATER ○ TIME DELAY ○ NOT USED ○ MAKING ICE ○ LOW BIN ○ POWER ON ✖	1. Internal water leak touching chassis sensor.	1. Identify and repair leak. Clean/dry chassis and sensors and restart machine.
6. Drain clog. CLEANER FULL ○ DRAIN CLOG ● HI PRESS ○ HI AMPS ○ SERVICE ○ MAINT/CLEAN ○ LOW WATER ○ TIME DELAY ○ NOT USED ○ MAKING ICE ○ LOW BIN ○ POWER ON ✖	1. Improper flow in drain system.	1. Correct/clean drain system.

Ice machine disposition	Possible causes	Corrective action
Legend: <input checked="" type="radio"/> ON <input type="radio"/> OFF <input type="radio"/> ON or OFF <input checked="" type="checkbox"/> FLASHING		
<p>7. Ice machine is making ice. Excessive water in bin or coming into bin from transport tube.</p> <p> CLEANER FULL <input type="radio"/> DRAIN CLOG <input type="radio"/> HI PRESS <input type="radio"/> HI AMPS <input type="radio"/> SERVICE <input type="radio"/> MAINT/CLEAN <input type="radio"/> LOW WATER <input type="radio"/> TIME DELAY <input type="radio"/> NOT USED <input type="radio"/> MAKING ICE <input checked="" type="radio"/> LOW BIN <input checked="" type="radio"/> POWER ON <input checked="" type="radio"/> </p>	<ol style="list-style-type: none"> 1. Failed water sensors. Processor assumes there is no water when there is water. 2. Blocked reservoir vent. 3. Defective water feed solenoid valve. Stuck in open position. 	<ol style="list-style-type: none"> 1. Clean or replace water probe assembly. Check wiring connections. 2. Clean or replace vent tubes. 3. Replace water feed solenoid valve.
<p>8. Ice machine is not making ice. Low Water.</p> <p> CLEANER FULL <input type="radio"/> DRAIN CLOG <input type="radio"/> HI PRESS <input type="radio"/> HI AMPS <input type="radio"/> SERVICE <input type="radio"/> MAINT/CLEAN <input type="radio"/> LOW WATER <input checked="" type="radio"/> TIME DELAY <input type="radio"/> NOT USED <input type="radio"/> MAKING ICE <input type="radio"/> LOW BIN <input type="radio"/> POWER ON <input checked="" type="radio"/> </p>	<ol style="list-style-type: none"> 1. Water supply is insufficient. 2. Low water pressure. 3. Defective water feed solenoid valve. Stuck in closed position. 4. No water feed output from PC board. 5. Plugged screen on inlet side of fill solenoid. 6. Plugged check valve. 	<ol style="list-style-type: none"> 1. Restore water supply and check water filters. If evaporator was completely empty the reset button may have to be pressed to restart the ice machine. 2. Ice machine will eventually start when water reaches normal lo level. 3. Replace water feed solenoid valve. 4. Replace PC board. 5. Remove and clean screen. 6. Remove and clean.
<p>9. Blinking Low Water, power, time delay.</p> <p> CLEANER FULL <input type="radio"/> DRAIN CLOG <input type="radio"/> HI PRESS <input type="radio"/> HI AMPS <input type="radio"/> SERVICE <input type="radio"/> MAINT/CLEAN <input type="radio"/> LOW WATER <input checked="" type="radio"/> TIME DELAY <input checked="" type="radio"/> NOT USED <input type="radio"/> MAKING ICE <input type="radio"/> LOW BIN <input type="radio"/> POWER ON <input checked="" type="radio"/> </p>	<p>Machine did not see water consumption while trying to make ice.</p> <ol style="list-style-type: none"> 1. Lack of refrigeration/low refrigerant charge/leak. 2. Debris shorting reservoir probes. 	<ol style="list-style-type: none"> 1. Verify refrigerant pressures, compressor running, sight glass clear. 2. Clean probes and reservoir of debris.



ATTENTION!

To prevent circuit breaker overload, wait 5 minutes before restarting this unit. This allows the compressor to equalize and the evaporator to thaw.

Warranty Registration and Equipment Evaluation

Thank you for purchasing Follett Products LLC equipment. Our goal is to earn your complete satisfaction by delivering high-value products and services backed by outstanding customer and technical support.

Please review the installation instructions thoroughly. It is important that the installation be performed to factory specifications so your equipment operates at its maximum efficiency.

Follett Products LLC will not be liable for any consequential damages, expenses, connecting or disconnecting charges, or any losses resulting from a defect of the machine. For full warranty details, visit our website www.follettice.com/productwarranties.

Registering your equipment helps Follett Products LLC track your equipment's service history should you need to contact us for technical support, and your feedback helps us improve our products and services. Please visit www.follettice.com/support to complete the Warranty Registration form.

Should you have any questions, please contact Follett's technical support group at (877) 612-5086 or (610) 252-7301 and we will be happy to assist you.

Horizon Elite, SafeCLEAN Plus and SaniSponge are trademarks of Follett Products, LLC
Follett is a registered trademark of Follett Products, LLC, registered in the US.



801 Church Lane • Easton, PA 18040, USA
Toll free (877) 612-5086 • +1 (610) 252-7301
www.follettice.com

01266543R06
© Follett Products, LLC 11/24