

D1810R, D2110R Horizon Elite™ Ice Machines (Remote Condensing)

User Guide
After Serial Number R03746

Please visit www.follettice.com/technicaldocuments
for the Operation and Service manual for your unit.

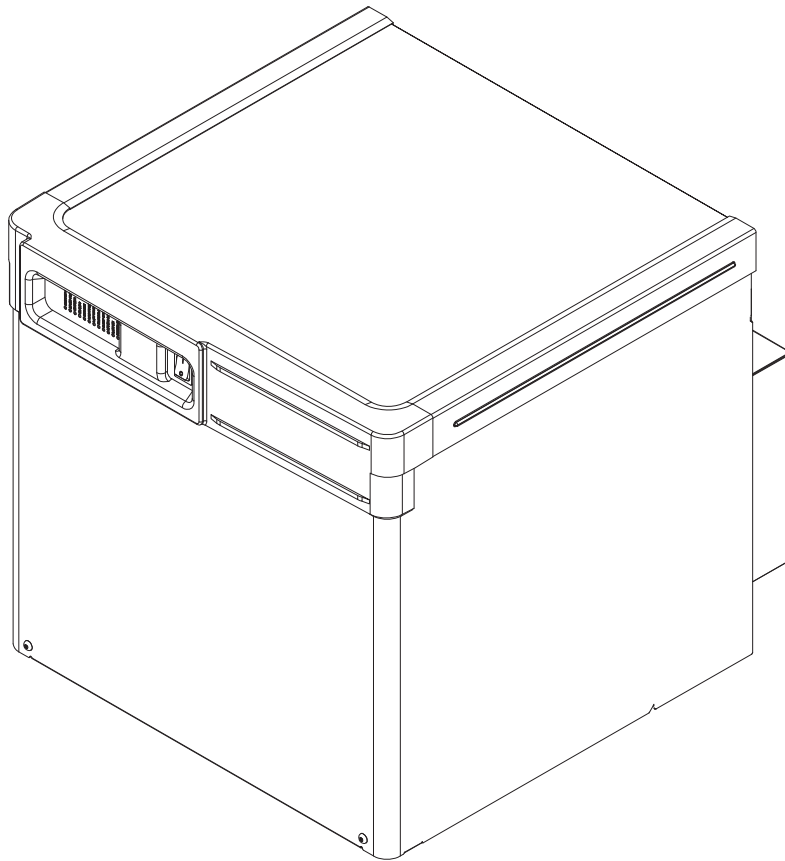

Welcome to Follett

Follett equipment enjoys a well-deserved reputation for excellent performance, long-term reliability and outstanding after-the-sale support. To ensure that this equipment delivers that same degree of service, review this guide carefully before you begin your installation.

Should you need technical help, please call our Technical Service group at (877) 612-5086 or (610) 252-7301.

Please have your model number, serial number and complete and detailed explanation of the problem when contacting Technical Service.

Getting Started

After uncrating and removing all packing material, inspect the equipment for concealed shipping damage. All freight is to be inspected upon delivery. If visible signs of damage exist, please refuse delivery or sign your delivery receipt "damaged." Follett Customer Service must be notified within 48 hours. Wherever possible, please include detailed photos of the damage with the original packaging so that we may start the freight claim process.



CAUTION

- Warranty does not cover exterior or outside installations.
- Moving parts. Do not operate with front cover removed.
- Hot parts. Do not operate with cover removed.
- To reduce risk of shock, disconnect power before servicing.
- Drain line must not be vented.
- Water supply must have particle filtration.
- Most ice machine cleaners contain citric or phosphoric acid, which can cause skin irritation. Read caution label on product and follow instructions carefully.
- Ice is slippery. Maintain counters and floors around dispenser in a clean and ice-free condition.
- Ice is food. Follow recommended cleaning instructions to maintain cleanliness of delivered ice.
- Follett recommends a Follett water filter system be installed in the ice machine inlet water line (standard capacity, high capacity, or carbonless high capacity).

Specifications

Electrical

Separate, dedicated circuit and equipment ground required.

Evaporator unit

Standard electrical: 115/60/1

Maximum fuse: 15A

Amperage: 5A

Condensing unit

	D1810CU Single-Phase	D1810CU 3-Phase	D2110CU Single-Phase	D2110CU 3-Phase
Electrical	208-230V, 60Hz			
Max Circuit HVACR breaker size	45A	25A	45A	30A
Min Circuit Ampacity	26.2A	15.7A	27.1A	19.9A

Plumbing



WARNING

This equipment to be installed with adequate backflow protection to comply with applicable federal, state, and local codes.

Notes:

- Follett does not recommend the use of water softeners or bowl scale inhibitors.
- The potable water total dissolved solids (TDS) content must be greater than 10 ppm for the water control system to function properly. If using reverse osmosis water filtration system, ensure TDS level is greater than 10 ppm.

Evaporator plumbing

- 3/8" OD push-in water inlet - 3/8" OD tubing required.
- Water shut-off recommended within 10 feet (3 m).

Flush drain plumbing

- 3/4" MPT flush drain connection at the rear of the machine.
- Drain must slope 1/4" inch per foot (6 mm per 30.4 cm).
- Drain line should not be shared with any other piece of equipment.
- Drain line cannot be reduced to a size smaller than 1 inch.
- Drain should be piped without a vent.

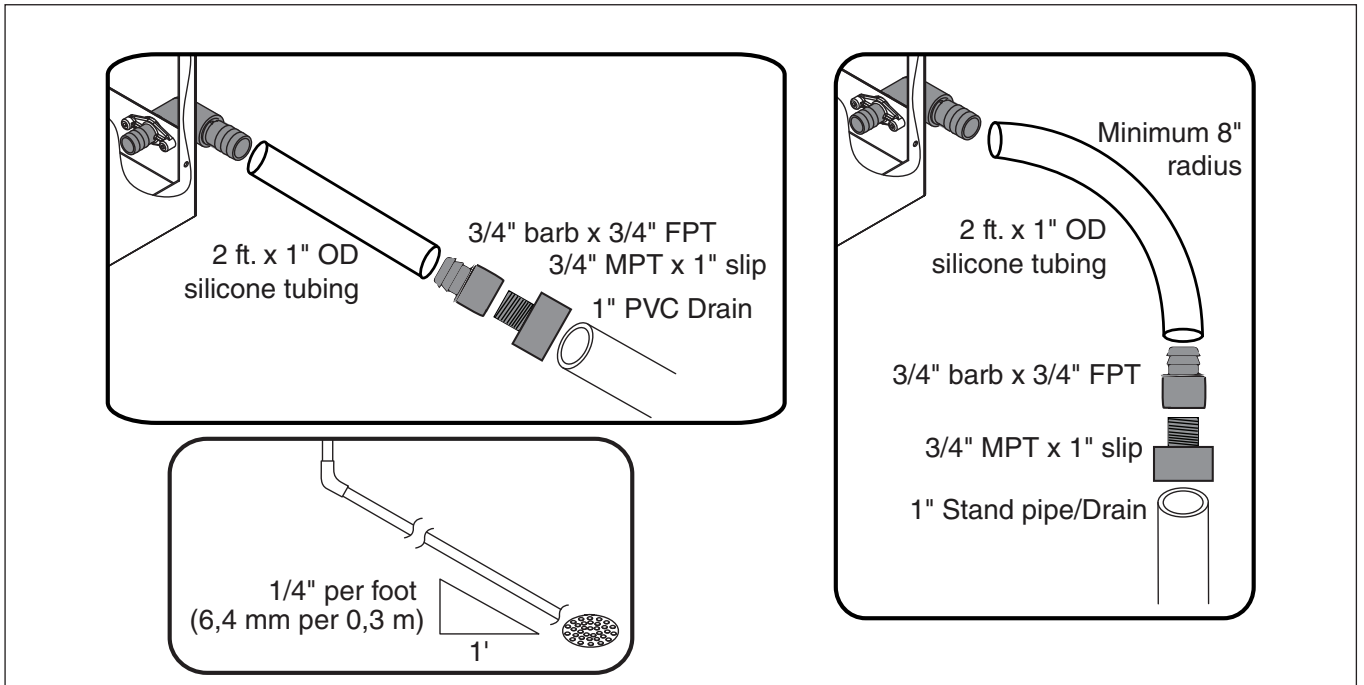

Chassis drain plumbing

- Plug must be removed from John Guest fitting.
- Route 3/8" drain tubing through knockout in back of docking station and insert fully into John Guest fitting connection at the rear of the machine chassis. Route other end of 3/8" drain tubing to drain.
- Drain must slope 1/4" inch per foot (6 mm per 30.4 cm).

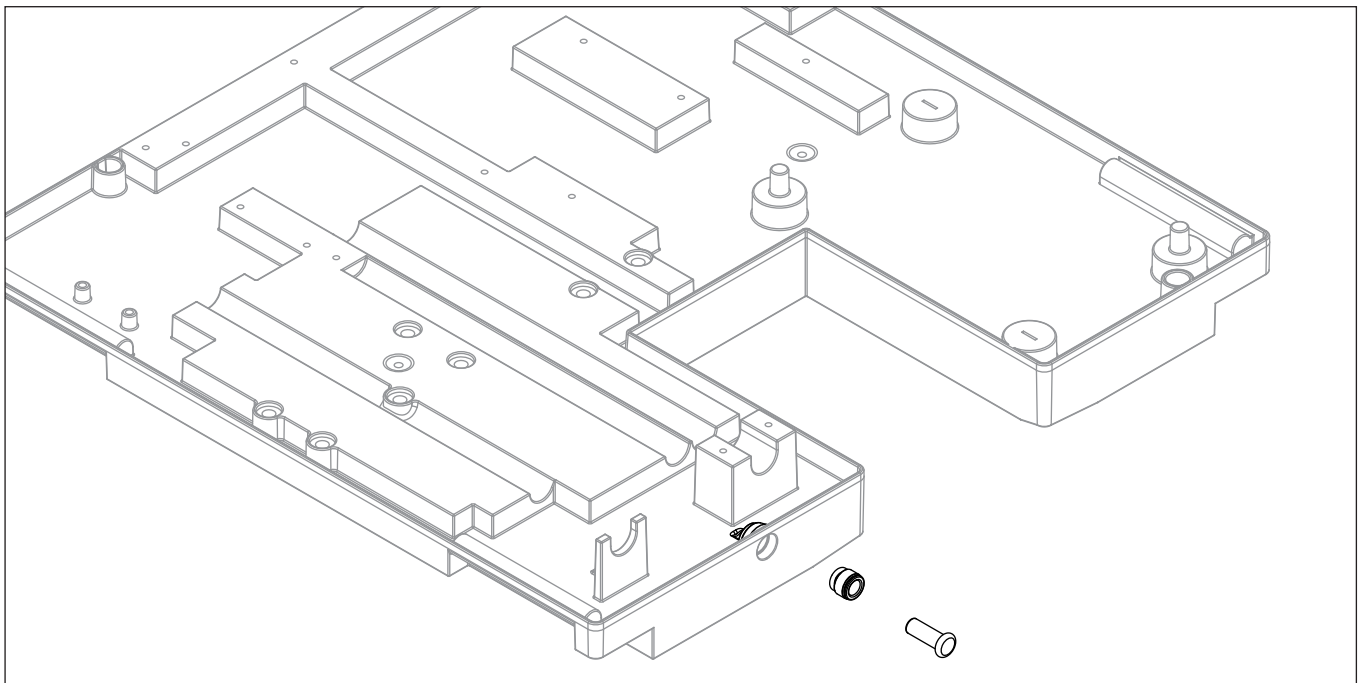

Ambient

Evaporator unit

Air temperature	100 F/38 C max.	50 F/10 C min.
Water temperature	90 F/32 C max.	45 F/7 C min.
Water pressure	70 psi max. (483 kPa)	10 psi min. (69 kPa)

Condenser unit

Air temperature	120 F/49 C max.	-20F/-29C min.
-----------------	-----------------	----------------

Refrigeration

- 3/8" liquid line
- 7/8" suction line

Note: Rack system installations require a capacity of 15,700 BTU/hr for 1810 machines and 18,200 BTU/hr for 2110 machines at 0 F (-18 C) evaporator temperature. Evaporator pressure regulator (not supplied) is required.

Weight

Evaporator unit:

1810: 157 lbs (71.2 kg)

2110: 165 lbs (74.8 kg)

Condensing unit: 305 lbs (138.3 kg)

Ice production

1810 ice machine capacity/24 hrs.

		Ambient Air Temperature F/C						
		F	60	70	80	90	100	
Evap Potable Water Temperature F/C	C	16	21	27	32	38		
	50	1859	1784	1685	1616	1500	lbs	
	10	843	809	764	733	680	kg	
	60	1723	1684	1578	1563	1409	lbs	
	16	782	764	716	709	639	kg	
	70	1620	1594	1514	1420	1319	lbs	
	21	734	723	687	644	598	kg	
	80	1550	1487	1485	1351	1299	lbs	
	27	703	674	674	613	589	kg	
	90	1471	1435	1370	1285	1207	lbs	
	32	667	651	621	583	547	kg	

2110 ice machine capacity/24 hrs.

		Ambient Air Temperature F/C						
		F	60	70	80	90	100	
Evap Potable Water Temperature F/C	C	16	21	27	32	38		
	50	2039	2039	1934	1825	1703	lbs	
	10	925	925	877	828	772	kg	
	60	1943	1888	1878	1710	1584	lbs	
	16	881	856	852	772	718	kg	
	70	1833	1781	1689	1634	1489	lbs	
	21	831	808	811	741	675	kg	
	80	1754	1686	1643	1535	1426	lbs	
	27	796	765	745	696	647	kg	
	90	1650	1603	1577	1457	1395	lbs	
	32	748	727	715	661	633	kg	

Dimensions and clearances

- Entire front of ice machine must be clear of obstructions/connections to allow removal.
- 1" (26mm) clearance above ice machine for service.
- 1" (26mm) minimum clearance on sides.

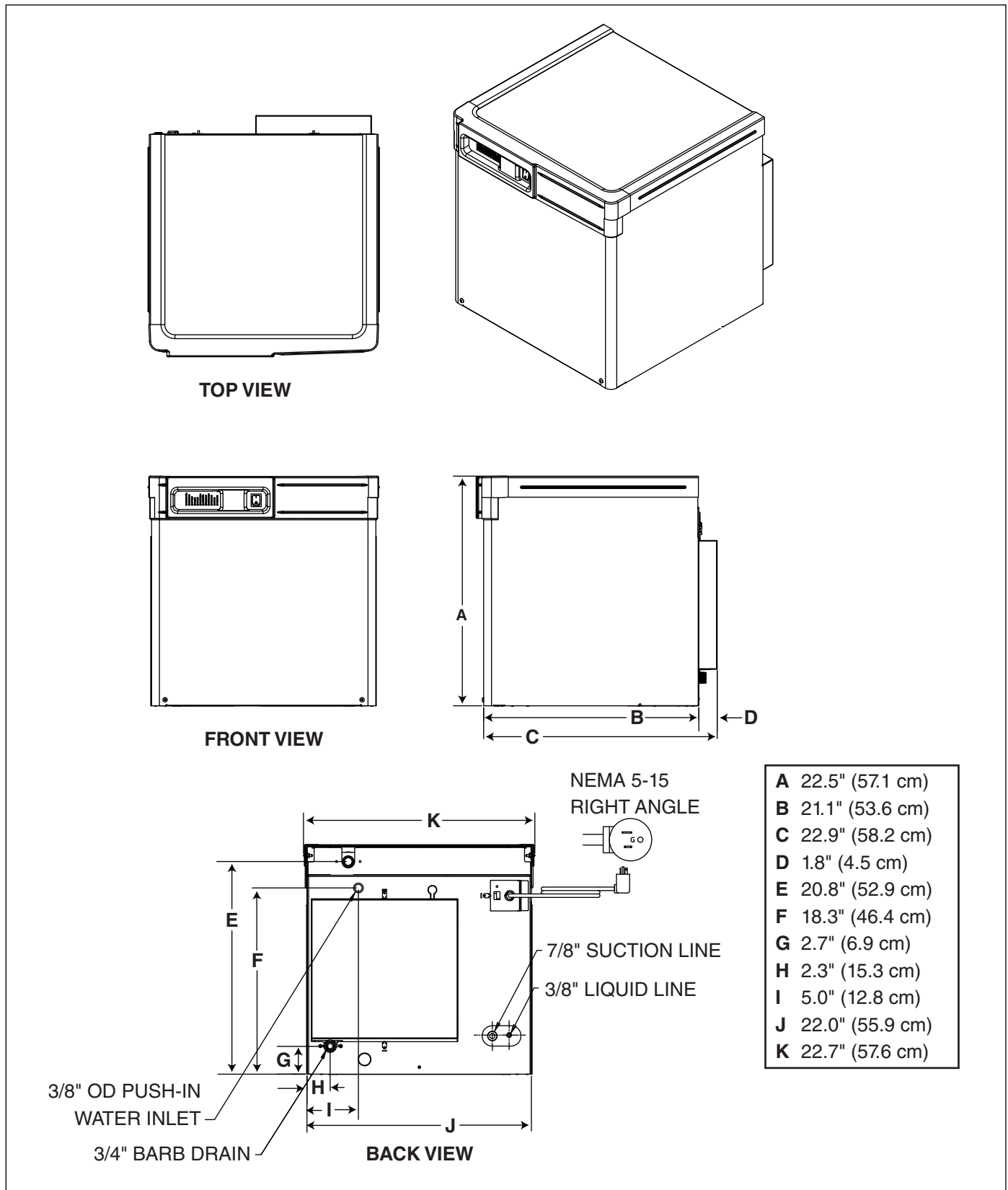

Condensing unit

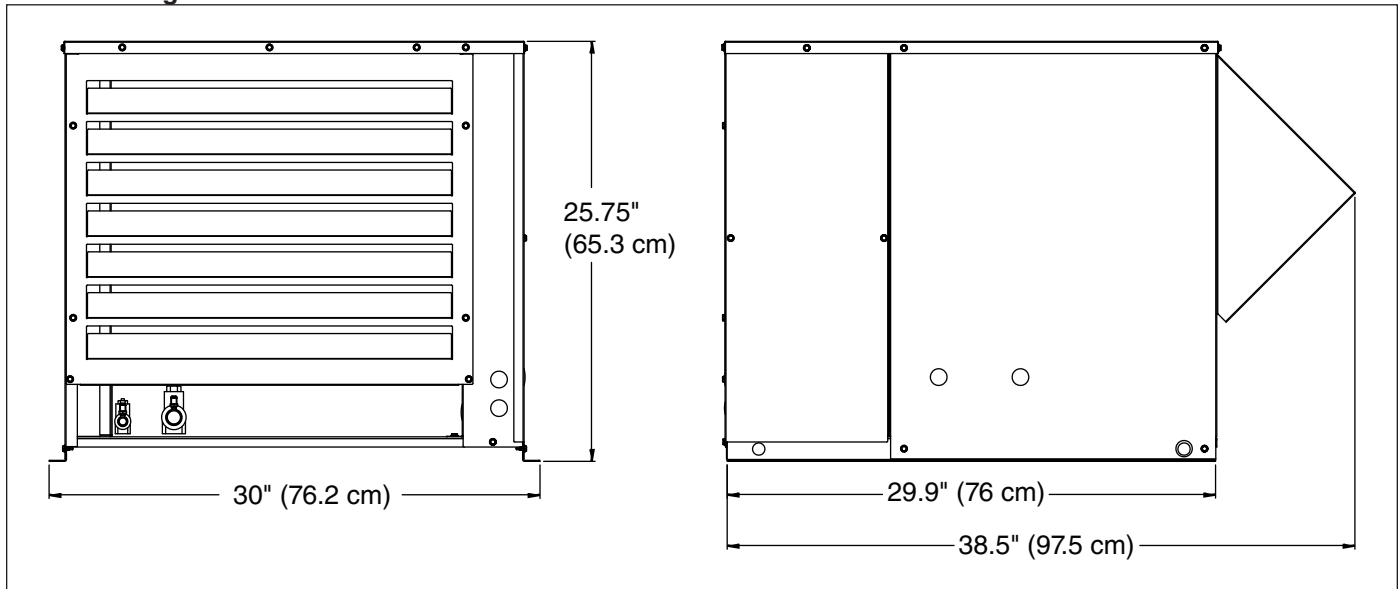

Operation

Cleaning/sanitizing and preventive maintenance (all models)

Note: Do not use bleach to sanitize or clean the icemaker.

Preventive maintenance

Periodic cleaning of Follett's icemaker system is required to ensure peak performance and delivery of clean, sanitary ice. The recommended cleaning procedures that follow should be performed at least as frequently as recommended, and more often if environmental conditions dictate.

Cleaning of the condenser can usually be performed by facility personnel. Cleaning of the icemaker system, in most cases, should be performed by your facility's maintenance staff or a Follett authorized service agent. Regardless of who performs the cleaning, it is the operator's responsibility to see that this cleaning is performed according to the schedule below. Service problems resulting from lack of preventive maintenance will not be covered under the Follett warranty.

Weekly exterior care

The exterior may be cleaned with a stainless cleaner such as 3M Stainless Steel Cleaner & Polish or equivalent.

Monthly condenser cleaning (air-cooled icemaker only)

1. Use a vacuum cleaner or stiff brush to carefully clean condenser coils of air-cooled icemakers to ensure optimal performance.
2. When reinstalling counter panels in front of remote icemakers, be sure that ventilation louvers line up with condenser air duct.

Semi-annual evaporator cleaning (every 6 months)

WARNING

- Wear rubber gloves and safety goggles (and/or face shield) when handling ice machine cleaner or sanitizer.

CAUTION

- Use only Follett approved SafeCLEAN Plus™ cleaning solution.
- DO NOT USE BLEACH.
- It is a violation of federal law to use these solutions in a manner inconsistent with their labeling.
- Read and understand all labels printed on packaging before use.

Note: Complete procedure for cleaning and sanitizing MUST be followed. Ice must be collected for 10 minutes before putting ice machine back into service.

1. Note position of TDS switch. Set to HIGH for duration of cleaning. Press the CLEAN button. The machine will fill and drain three times (**approximately 5 minutes**). The auger will run for a short time and then stop. Wait for the LOW WATER light to come on.

Fig. 1

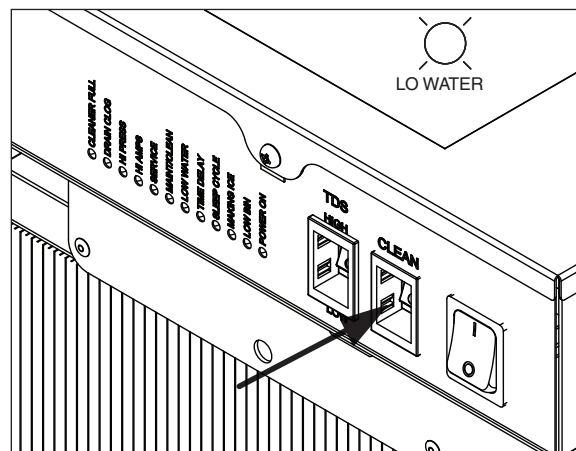

2. Follow the directions on the SafeCLEAN Plus packaging to mix 1 gal. (3.8 L) of Follett SafeCLEAN Plus solution. Use 120 F (49 C) water.
3. Using a 1 quart (1 L) container, slowly fill cleaning cup until CLEANER FULL light comes on and cleaner just begins to flow from the vent tube.
4. Place two SaniSponge™ cleaning sponges in remaining sanitizing and cleaning solution and retain for Step 9.

Note: Do not use bleach to sanitize or clean the icemaker.

Fig. 2

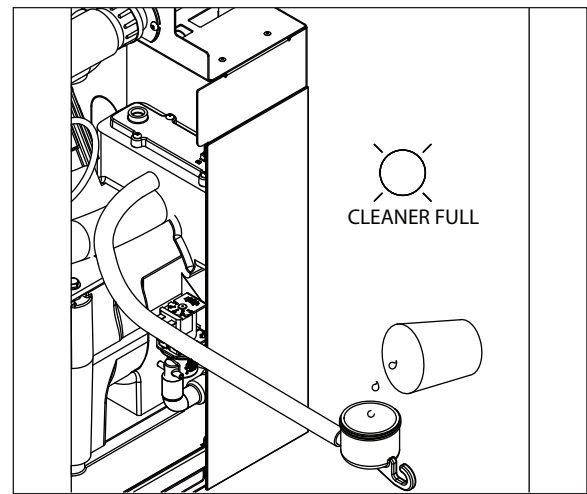

5. Replace cover on cleaner cup. Machine will clean, then flush 3 times in approximately 15 minutes. Wait until machine restarts.

Fig. 3

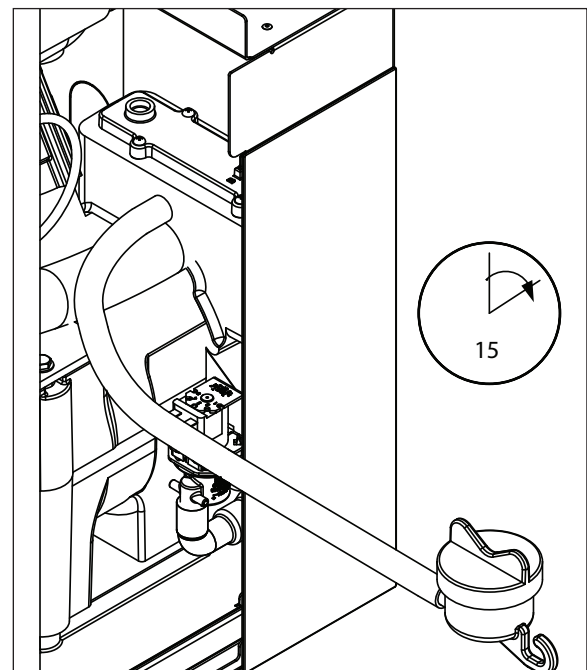

6. To clean/sanitize ice transport tube – Press power switch OFF

Fig. 4

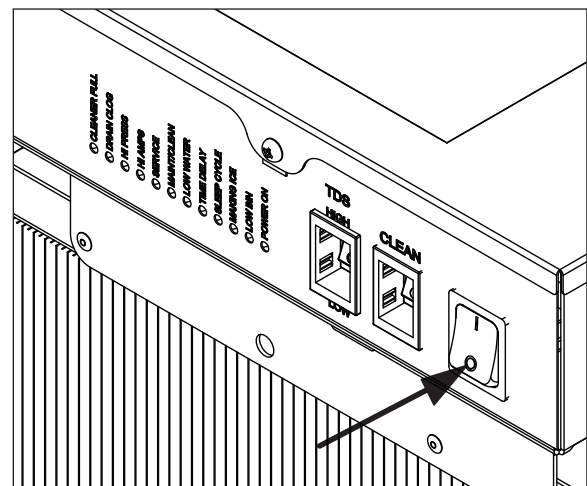

7. Disconnect coupling as shown.

Fig. 5

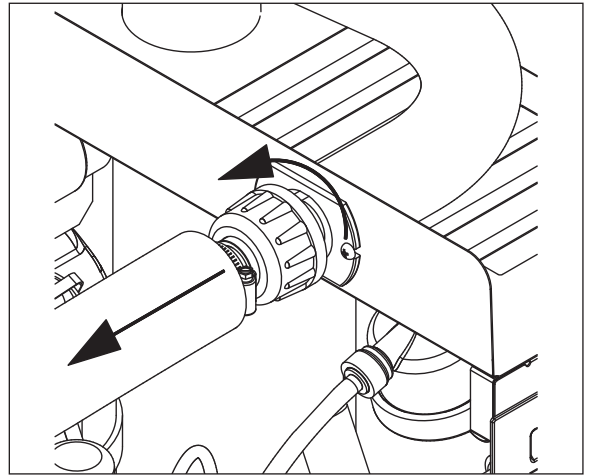

- 8. Using disposable foodservice grade gloves, insert both SaniSponge cleaning sponges saturated in SafeClean Plus (from Step 4).
- 9. Push both SaniSponge cleaning sponges down ice transport tube with supplied pusher tube.

Fig. 6

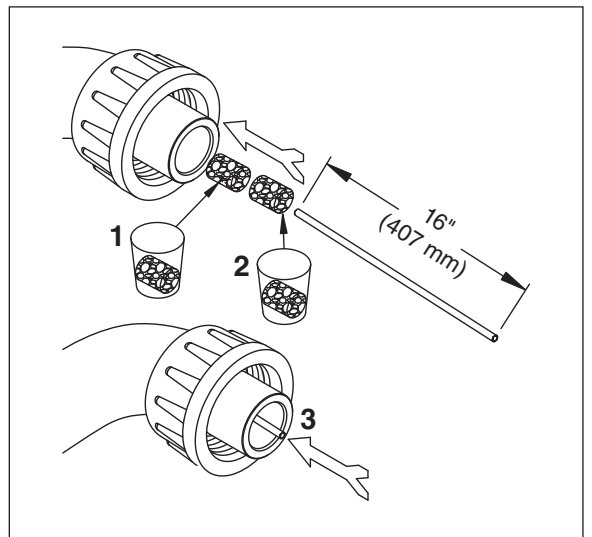

10. Remove and discard 16 inch (407 mm) pusher tube.

Fig. 7

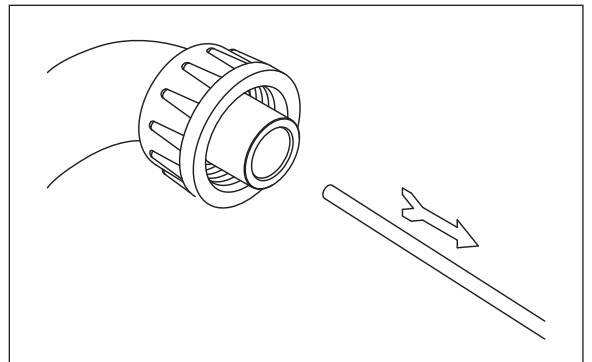

11. Reconnect coupling. Press power switch ON. Ice pushes SaniSponge cleaning sponges through ice transport tube.

Fig. 8

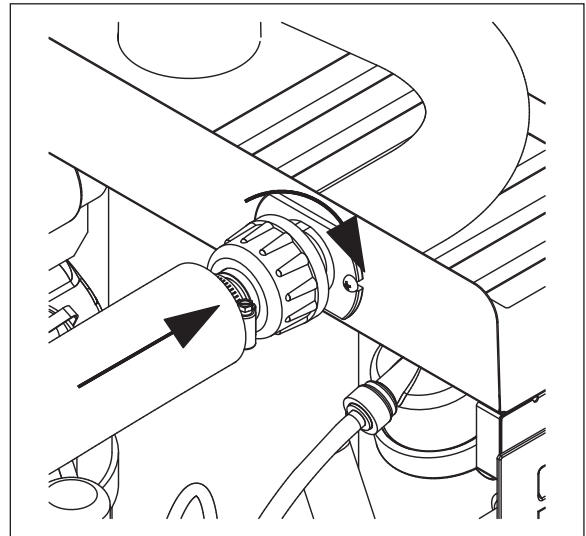

12. Place a sanitary (2 gal. or larger) container in bin or dispenser to collect SaniSponge cleaning sponges and ice for 10 minutes after the Sani-Sponges come out.
13. Discard ice and Sani-Sponges. Return TDS switch to the original position.

Fig. 9

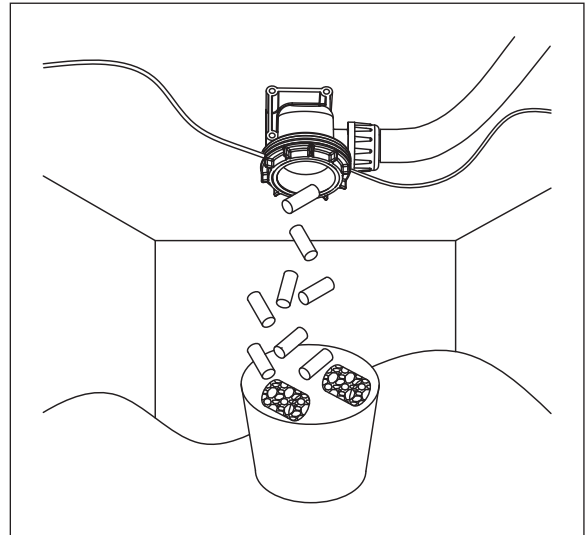

Wiring diagram, evaporator unit

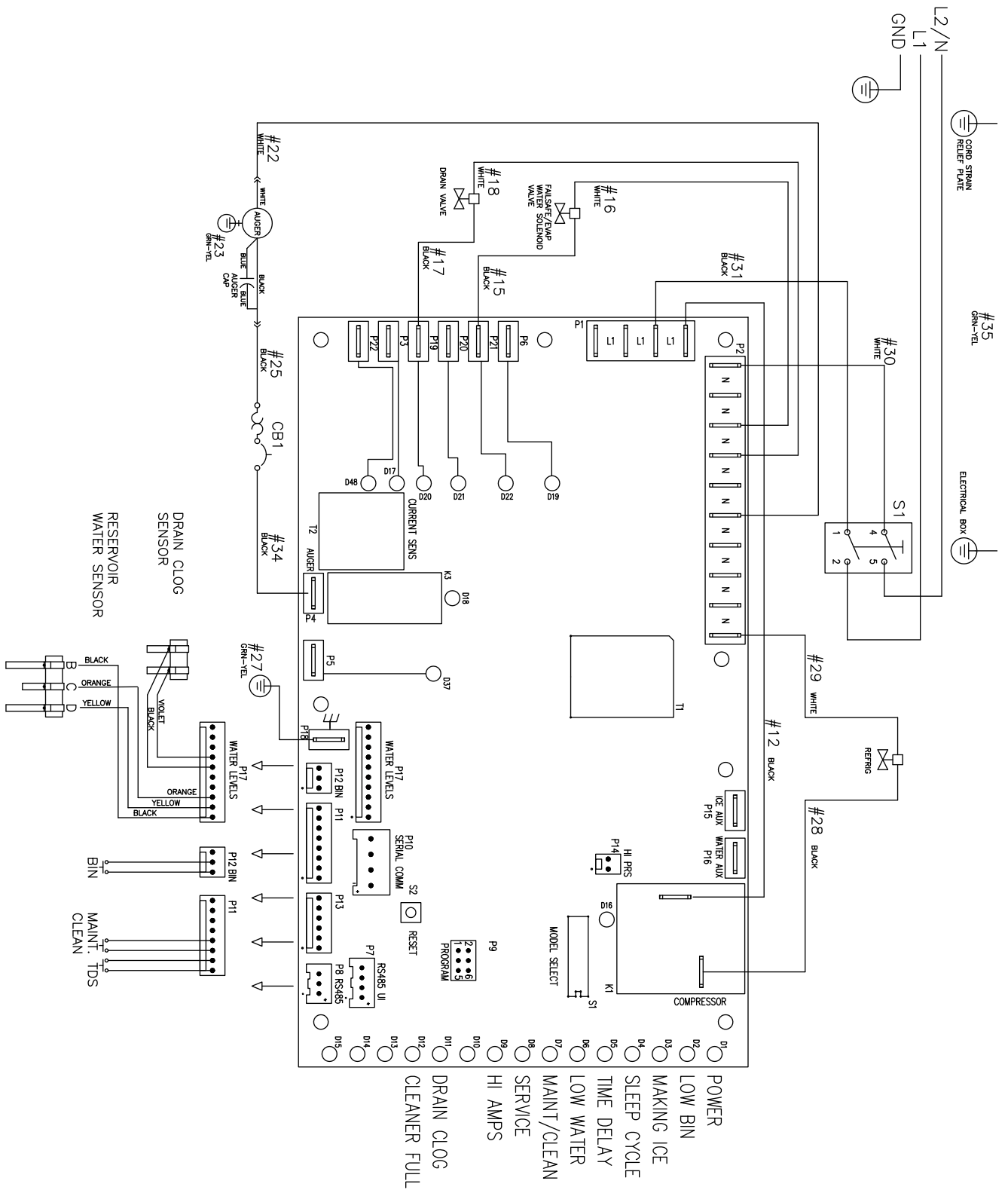

Gearmotor data

Gearmotor current 4.0A @ 115 V

Gearmotor torque-out (high amp) trip point: 7.0A

Single-phase condensing unit wiring diagram

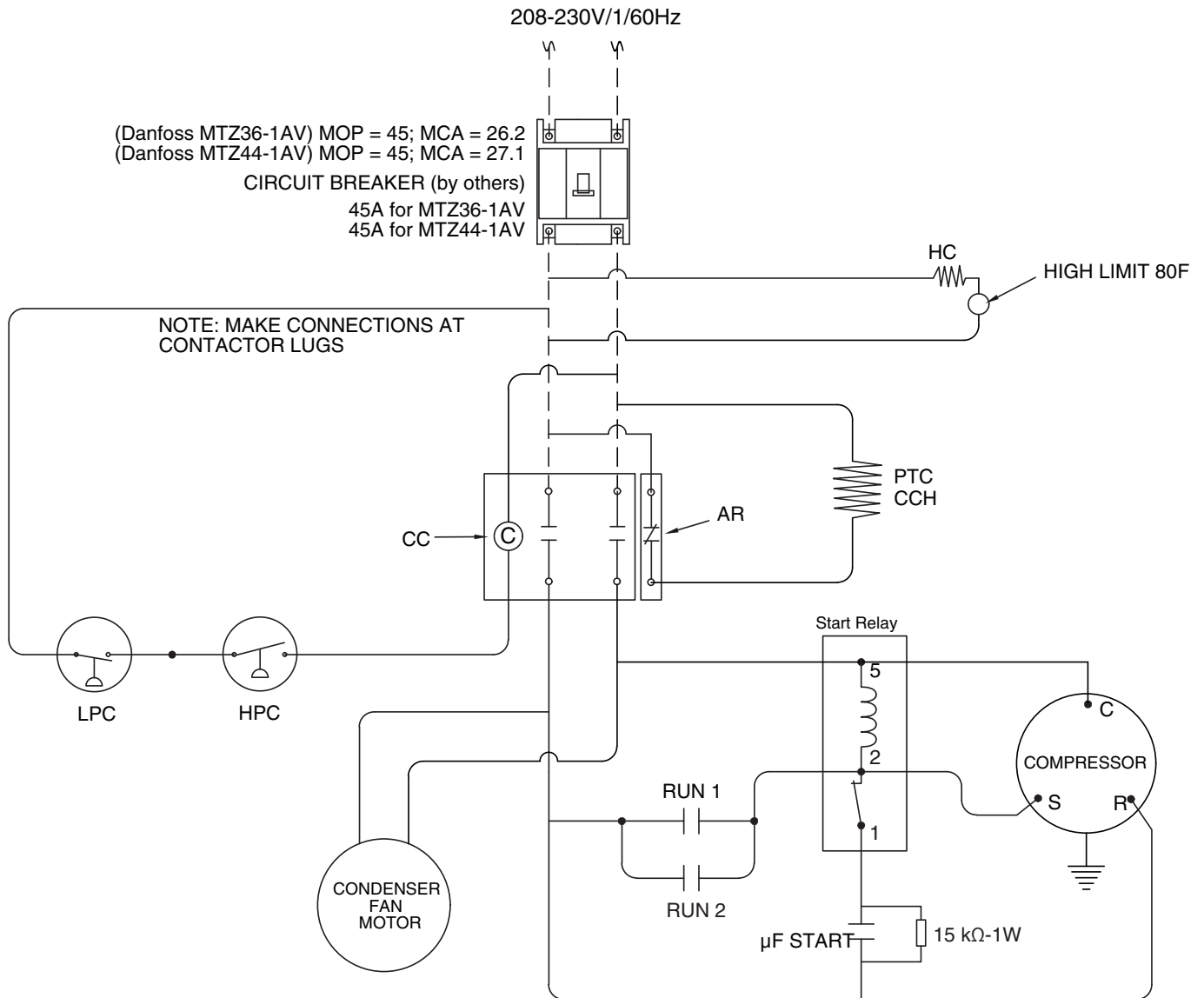

Danfoss Reciprocating Compressor: 3-phase condensing unit wiring diagram

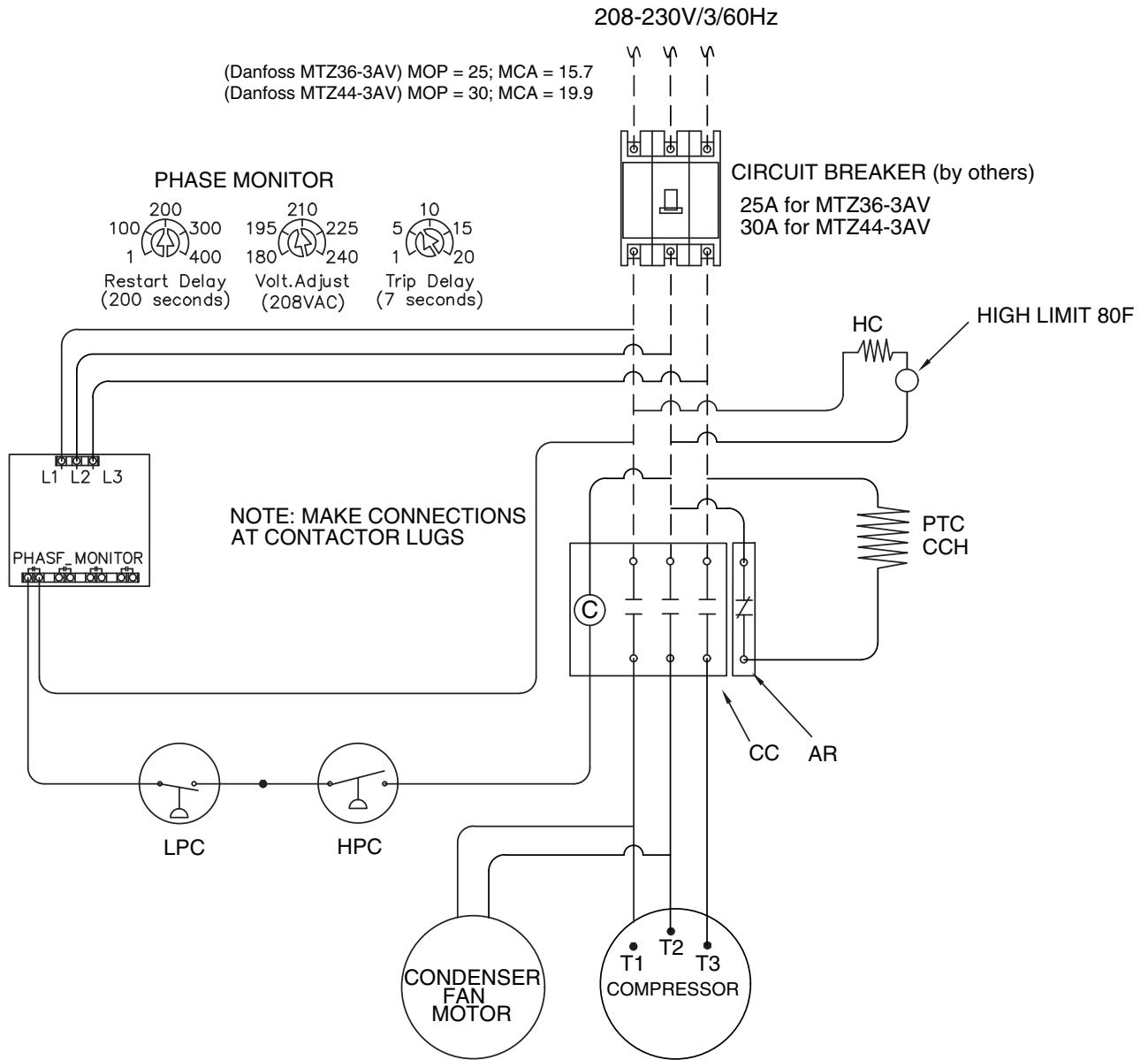

Copeland Scroll Compressor: 3-phase condensing unit wiring diagram

MODEL: MHHZ0303C
(Copeland ZS19KAE-TF5) MOP = 29.8; MCA = 27.5

208-230 V/3PH/60 Hz

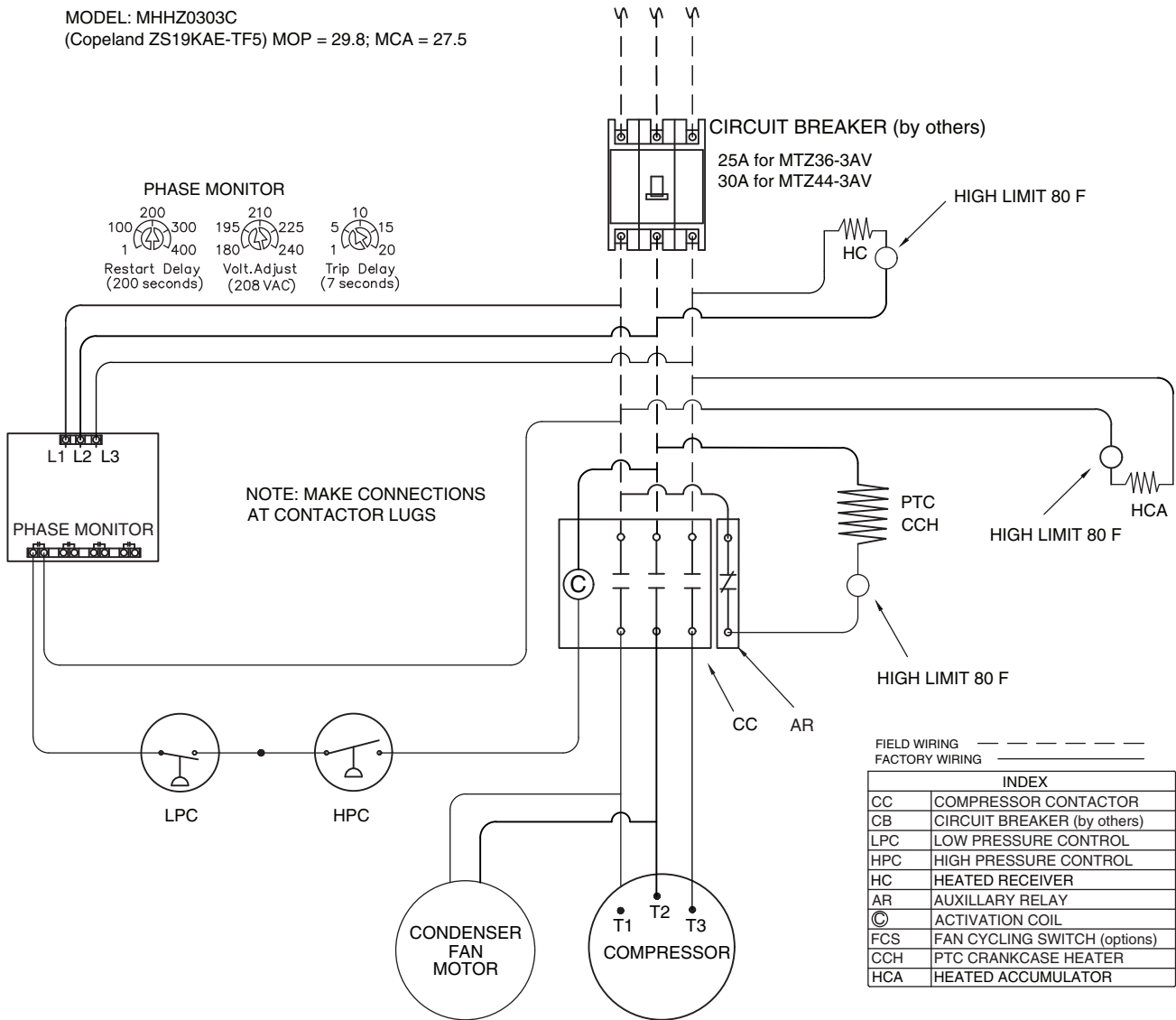

Refrigeration system

1810 - Operating Pressure (Discharge PSIG/Suction PSIG)

Water Temperature F/C		50	60	70	80	90
Ambient Outdoor Temperature F/C	F					
	C	10	16	21	27	32
	60	182/27	182/27	182/27	182/27	183/27
	16					
	70	188/28	188/28	188/28	188/27	188/27
	21					
	80	218/30	218/30	218/30	218/30	219/30
	27					
	90	249/32	249/32	249/32	249/32	249/32
	32					
100	282/34	282/34	282/34	282/34	282/34	
38						

2110 - Operating Pressure (Discharge PSIG/Suction PSIG)

Water Temperature F/C		50	60	70	80	90
Ambient Outdoor Temperature F/C	F					
	C	10	16	21	27	32
	60	189/28	188/28	189/28	188/27	186/27
	16					
	70	192/28	191/28	192/28	192/28	191/28
	21					
	80	220/29	219/30	219/30	219/31	220/31
	27					
	90	252/33	252/33	252/33	252/33	252/33
	32					
100	285/35	285/35	284/35	284/35	285/34	
38						

Refrigeration system diagram

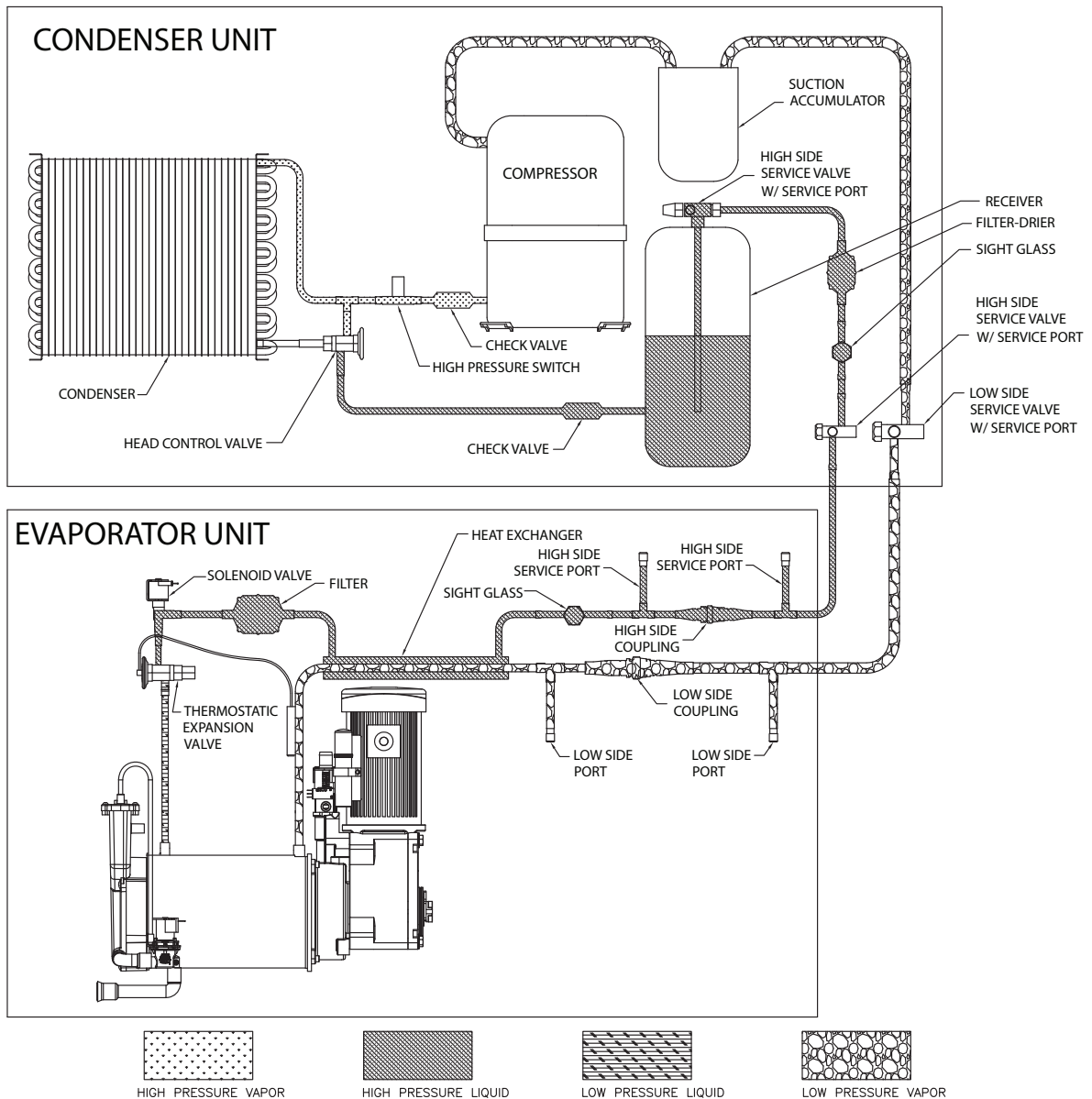

Refrigeration charge

All service on refrigeration systems must be performed in accordance with all federal, state and local laws. It is the responsibility of the technician to ensure that these requirements are met. Recharging ice machine to other than factory specifications will void the warranty.

Attention: Unit must be charged by weight, not by clear sight glass.

R404A ice machine charge specifications for 1810/2110 models with line runs of 0 to 75 ft. (0 m to 22.8 m)

Total charge	14.5 lbs (6.57 kg)
Condensing unit holding charge	0.5 lbs (0.23 kg)
Charge at installation	14 lbs (6.35 kg)

Note: Condensing unit shipped with 0.5 lb of R404A charge.

Refrigerant replacement requirements

1. Non-contaminated refrigerant removed from any Follett refrigeration system can be recycled and returned to the same system after completing repairs. Recycled refrigerant must be stored in a clean, approved storage container. If additional refrigerant is required, virgin or reclaimed refrigerant that meets ARI standard 700-88 must be used.
2. In the event of system contamination (for example, a compressor burn out, refrigerant leak, presence of non-condensibles or moisture), the system must be repaired, evacuated and recharged using virgin or reclaimed refrigerant that meets ARI standard 700-88.
3. Follett LLC does not approve of recovered refrigerants. Improper refrigeration servicing procedures will void the factory warranty.

Evacuation

Evacuate the system to a level of 500 microns. When the 500 micron level is reached, close all valves. Allow the system to sit for approximately 20 minutes. During this period the system pressure should not rise. If the system pressure rises and stabilizes there is moisture in the system and further evacuation is needed. If the pressure continues to rise check the system for leaks.

Ambients	Minimum	Maximum
Air temperature ¹	50 F/10 C	100 F/37.8 C
Water temperature ²	45 F/7 C	90 F/32.2 C

¹Ambient air temperature is measured at the air-cooled condenser coil inlet.

²Ambient water temperature is measured in the ice machine water reservoir.

Ice capacity test

Ice machine production capacity can only be determined by weighing ice produced in a specific time period.

1. Replace all panels on ice machine.
2. Run ice machine for at least 15 minutes.
3. Move TDS switch to LOW.
4. Press the reset button on the board.

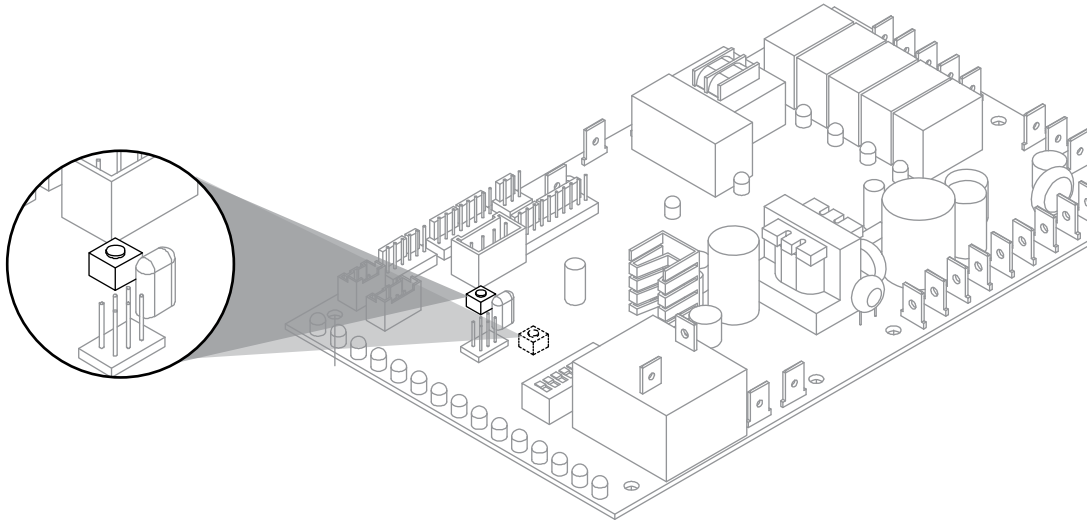

5. Weigh and record weight of container used to catch ice.
6. Catch ice for 15 minutes.
7. Weigh harvested ice and record total weight.
8. Subtract weight of container from total weight.
9. Convert fractions of pounds to decimal equivalents (ex. 6 lbs 8 oz = 6.5 lbs).
10. Calculate production using following formula:

$$\frac{1440 \text{ min.} \times \text{wt. of ice produced}}{\text{Total test time in minutes}} = \text{Production capacity/24 hr.}$$

11. Calculated amount per 24 hours should be checked against rated capacity for same ambient and water temperatures in Ice Production Tables.
12. Move TDS switch to the HI TDS position.

Condenser installation specifications

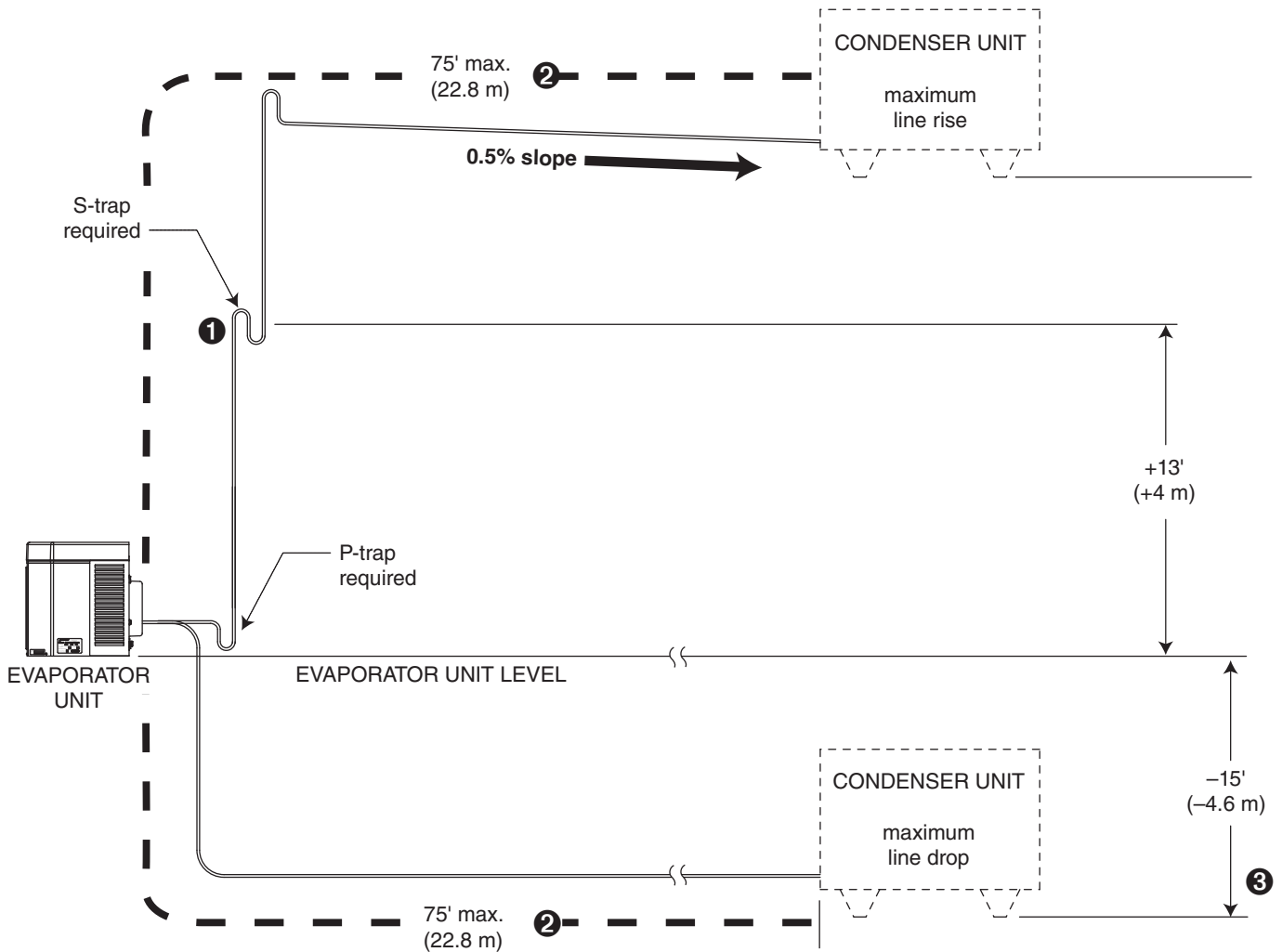

Site layout:

- Outdoor ambient temperature range: -20 F to 120 F (-29 C to 49 C)
- Installation with condenser unit elevations above 13' (4 m) require an S-trap at the midpoint of the rise. A P-trap is required at the foot of each vertical riser. If the riser is higher than 13' (4 m), additional P-traps are required for each additional 13' (4 m) ❶.
- Maximum line set length must not exceed 75' (22.8 m) ❷
- Maximum line drop must not exceed 15' (4.6 m) ❸

Troubleshooting

Ice machine disposition	Possible causes	Corrective action
Legend: <input checked="" type="radio"/> ON <input type="radio"/> OFF <input type="radio"/> ON or OFF <input checked="" type="radio"/> FLASHING		
1. Ice machine is in running condition but not making ice. CLEANER FULL <input type="radio"/> DRAIN CLOG <input type="radio"/> HI PRESS <input type="radio"/> HI AMPS <input type="radio"/> SERVICE <input type="radio"/> MAINT/CLEAN <input type="radio"/> LOW WATER <input type="radio"/> TIME DELAY <input type="radio"/> NOT USED <input type="radio"/> MAKING ICE <input checked="" type="radio"/> LOW BIN <input checked="" type="radio"/> POWER ON <input checked="" type="radio"/>	1. Defective compressor. 2. Defective start relay. 3. Defective start capacitor. 4. Defective run capacitor. 5. Defective main contactor. 6. No output from PC board.	1. Replace compressor. 2. Replace start relay. 3. Replace start capacitor. 4. Replace run capacitor. 5. Replace main contactor. 6. Replace PC board.
2. Machine in TIME DELAY without full bin. CLEANER FULL <input type="radio"/> DRAIN CLOG <input type="radio"/> HI PRESS <input type="radio"/> HI AMPS <input type="radio"/> SERVICE <input type="radio"/> MAINT/CLEAN <input type="radio"/> LOW WATER <input type="radio"/> TIME DELAY <input checked="" type="radio"/> NOT USED <input type="radio"/> MAKING ICE <input type="radio"/> LOW BIN <input type="radio"/> POWER ON <input type="radio"/>	1. Ice jamming due to improperly installed transport tube causing a false shuttle. 2. Shuttle stuck in up position. 3. Damaged or improperly installed thermostat (open). 4. Transport tube backed-out of coupling.	1. Correct transport tube routing. 2. Repair or replace shuttle mechanism. 3. Replace or reposition thermostat. 4. Correct coupling installation.
3. Ice machine is not making ice. HI AMPS. CLEANER FULL <input type="radio"/> DRAIN CLOG <input type="radio"/> HI PRESS <input type="radio"/> HI AMPS <input checked="" type="radio"/> SERVICE <input type="radio"/> MAINT/CLEAN <input type="radio"/> LOW WATER <input type="radio"/> TIME DELAY <input type="radio"/> NOT USED <input type="radio"/> MAKING ICE <input type="radio"/> LOW BIN <input type="radio"/> POWER ON <input checked="" type="radio"/>	1. Poor water quality causing ice to jam auger. 2. Damaged shuttle mechanism. 3. Intermittent drive output from PC board. Evaporator will freeze causing a HI AMPS error. 4. Gearmotor is unplugged.	1. Clean ice machine. Increase flushing frequency. Position TDS switch to High TDS setting. 2. Replace or repair shuttle mechanism. 3. Replace PC board. 4. Plug in gearmotor.
4. Ice machine is not making ice. HI PRESSURE. CLEANER FULL <input type="radio"/> DRAIN CLOG <input type="radio"/> HI PRESS <input checked="" type="radio"/> HI AMPS <input type="radio"/> SERVICE <input type="radio"/> MAINT/CLEAN <input type="radio"/> LOW WATER <input type="radio"/> TIME DELAY <input type="radio"/> NOT USED <input type="radio"/> MAKING ICE <input type="radio"/> LOW BIN <input type="radio"/> POWER ON <input checked="" type="radio"/>	1. High ambient temperatures >100 F (38 C). 2. Poor ventilation or air recirculation. 3. Clogged condenser (air-cooled). 4. No water flow through condenser (water-cooled). 5. Fan not working properly. No air flow. <ul style="list-style-type: none"> • Blocked fan blades • No fan output from PC board • Faulty fan motor 	1. Air condition area to below 100 F (38 C). 2. Reposition ice machine or properly ventilate. Prevent ice machine exhaust from recirculating. 3. Clean condenser grille (air-cooled). 4. Restore water flow to condenser. 5. Correct air flow. <ul style="list-style-type: none"> • Remove any blockage from fan blades • Replace PC board • Replace fan motor
5. Ice machine is not making ice. SERVICE. CLEANER FULL <input type="radio"/> DRAIN CLOG <input type="radio"/> HI PRESS <input type="radio"/> HI AMPS <input type="radio"/> SERVICE <input checked="" type="radio"/> MAINT/CLEAN <input type="radio"/> LOW WATER <input type="radio"/> TIME DELAY <input type="radio"/> NOT USED <input type="radio"/> MAKING ICE <input type="radio"/> LOW BIN <input type="radio"/> POWER ON <input checked="" type="radio"/>	1. Internal water leak touching chassis sensor.	1. Identify and repair leak. Clean/dry chassis and sensors and restart machine.
6. Drain clog. CLEANER FULL <input type="radio"/> DRAIN CLOG <input checked="" type="radio"/> HI PRESS <input type="radio"/> HI AMPS <input type="radio"/> SERVICE <input type="radio"/> MAINT/CLEAN <input type="radio"/> LOW WATER <input type="radio"/> TIME DELAY <input type="radio"/> NOT USED <input type="radio"/> MAKING ICE <input type="radio"/> LOW BIN <input type="radio"/> POWER ON <input checked="" type="radio"/>	1. Improper flow in drain system.	1. Correct/clean drain system.

Ice machine disposition	Possible causes	Corrective action
Legend: ● ON ○ OFF ◐ ON or OFF ✖ FLASHING		
7. Ice machine is making ice. Excessive water in bin or coming into bin from transport tube. CLEANER FULL ○ DRAIN CLOG ○ HI PRESS ○ HI AMPS ○ SERVICE ○ MAINT/CLEAN ○ LOW WATER ○ TIME DELAY ○ NOT USED ○ MAKING ICE ● LOW BIN ● POWER ON ✖	1. Failed water sensors. Processor assumes there is no water when there is water. 2. Blocked reservoir vent. 3. Defective water feed solenoid valve. Stuck in open position.	1. Clean or replace water probe assembly. Check wiring connections. 2. Clean or replace vent tubes. 3. Replace water feed solenoid valve.
8. Ice machine is not making ice. Lo water. CLEANER FULL ○ DRAIN CLOG ○ HI PRESS ○ HI AMPS ○ SERVICE ○ MAINT/CLEAN ○ LOW WATER ● TIME DELAY ○ NOT USED ○ MAKING ICE ○ LOW BIN ◐ POWER ON ✖	1. Water supply is insufficient. 2. Low water pressure. 3. Defective water feed solenoid valve. Stuck in closed position. 4. No water feed output from PC board. 5. Plugged screen on inlet side of fill solenoid. 6. Plugged check valve.	1. Restore water supply and check water filters. If evaporator was completely empty the reset button may have to be pressed to restart the ice machine. 2. Ice machine will eventually start when water reaches normal lo level. 3. Replace water feed solenoid valve. 4. Replace PC board. 5. Remove and clean screen. 6. Remove and clean.
9. Blinking Lo water, power, time delay. CLEANER FULL ○ DRAIN CLOG ○ HI PRESS ○ HI AMPS ○ SERVICE ○ MAINT/CLEAN ○ LOW WATER ✖ TIME DELAY ● NOT USED ○ MAKING ICE ○ LOW BIN ◐ POWER ON ✖	Machine did not see water consumption while trying to make ice. 1. Lack of refrigeration/low refrigerant charge/leak. 2. Debris shorting reservoir probes.	1. Verify refrigerant pressures, compressor running, sight glass clear. 2. Clean probes and reservoir of debris.



ATTENTION!

To prevent circuit breaker overload, wait 5 minutes before restarting this unit. This allows the compressor to equalize and the evaporator to thaw.

Warranty Registration and Equipment Evaluation

Thank you for purchasing Follett equipment. Our goal is to earn your complete satisfaction by delivering high-value products and services backed by outstanding customer and technical support.

Please review the installation instructions thoroughly. It is important that the installation be performed to factory specifications so your equipment operates at its maximum efficiency.

Follett LLC will not be liable for any consequential damages, expenses, connecting or disconnecting charges, or any losses resulting from a defect of the machine. For full warranty details, visit our website www.follettice.com/productwarranties.

Registering your equipments helps Follett track your equipment's service history should you need to contact us for technical support, and your feedback helps us improve our products and services. Please visit www.follettice.com/support to complete the Warranty Registration form.

Should you have any questions, please contact Follett's technical support group at (877) 612-5086 or (610) 252-7301 and we will be happy to assist you.

Ice Manager, SafeCLEAN Plus, SaniSponge and Vision are trademarks of Follett Products, LLC. Chewblet, RIDE and Follett are registered trademarks of Follett Products, LLC, registered in the US.