

Maestro Plus™ ice machine bin

425 series for foodservice applications



Features

Up to 425 lb (193 kg) of production and 75 lb (34 kg) of storage capacity. Perfect for space limited facilities. Less than 24.00" (61.0 cm) wide, the Maestro Plus ice machine bin will provide the capacity you need in a small footprint.

- Undercounter application without the legs: 33.00" (83.8 cm) tall unit will fit under standard counters. Teflon glides allow it to slide easily into place.
- Freestanding: 39.00" (99.1 cm) tall with legs

Consumer-preferred Micro Chewblet ice (also available as a flaker)

- preferred over cubes by more than 2:1¹
- easy to chew
- slow melting, maintains drink temperature and quality, comparable to cubes
- higher displacement than cube ice

Flake ice is perfect for display

- securely supports salad bar containers without tipping
- cradles fish and vegetables without bruising

High performance Maestro Plus ice machines

- stainless steel evaporator, auger and top bearing provides durability
- oversized, heavy duty, tapered roller bearing ensures long low-maintenance life
- semi-automatic cleaning cycle reduces maintenance costs
- regular flushing improves ice quality and reduces scale

Lower utility bills

- energy-efficient, no costly defrost cycles
- 25% less energy than comparable capacity cube machines
- 40% less water than comparable capacity cube machines

Designed for easy installation and service

- front ventilated - no side, top or back clearance required
- rear utility access allows for rear electrical and plumbing connection with no rear clearance required
- bin and shroud may be removed for service and maintenance

Warranty

- 3 years parts and labor, 5 years compressor parts

¹ Consumer study conducted by independent agency Roper ASW.

Ice Production	Ice type	V/Hz/Ph	Item number
425 lb (193 kg)	Micro Chewblet™	115/60/1	UMD425A80†
	Flake	115/60/1	UFD425A80

† ENERGY STAR® certified



Job

Item

Specification

Ice storage capacity	75 lb (34 kg)
W1 Width	23.50" (59.7 cm)
D1 Depth	26.00" (66.0 cm)
H1 Height with legs	39.00" (99.0 cm)
H2 Height without legs	33.00" (83.8 cm)
Service and ventilation clearance	front ventilated - no side, top or back clearance required
Utility connection location	back
C1 Electrical	8 amps, 115 V/60/1
C2 Potable water inlet	7' (2 m) cord, NEMA 5-15 plug
C3 Drain	3/8" push in
	3/4" MPT when unit is installed without legs, floor drain must be within 6' (1.8 m)
Air temperature	50 - 100 F (10 - 38 C)
Water temperature	40 - 90 F (4 - 32 C)
Potable water pressure	10 - 70 psi (69 - 483 kpa) 0.7 Bar - 5 Bar max
Ice production at 70 F (21 C) air and 50 F (10 C) water	425 lb (193 kg)
Ice production at 90 F (32 C) air and 70 F (21 C) water	325 lb (147 kg)
Energy consumption 90 F (32 C) air; 70 F (21 C) water	5.4 kWh
Heat rejection	5,000 BTU/hr
Water consumption	12.0 gal (45.4 L) of potable water per 100 lb (45.4 kg) of ice
Approximate ship weight	194 lb (88 kg)

NOTE: For indoor use only. Designed for commercial use. Follett is not able to provide in-house services for residential installations.

SHORT FORM SPECIFICATION: Ice machine to be Follett model number _____
Ice machine to be air-cooled and production to be approximately 425 lb (193 kg) per day of _____ Micro Chewblet or _____ flake ice at air temp of 70 F (21 C) and water temp of 50 F (10 C). Ice storage capacity of up to 75 lb (34 kg). Ice machine to use environmentally responsible R404a refrigerant. Ice machine to have stainless steel evaporator, auger, top bearings, heavy duty tapered roller bearings, and low water safety circuit. NSF and ETL listed.

Dimensional drawing

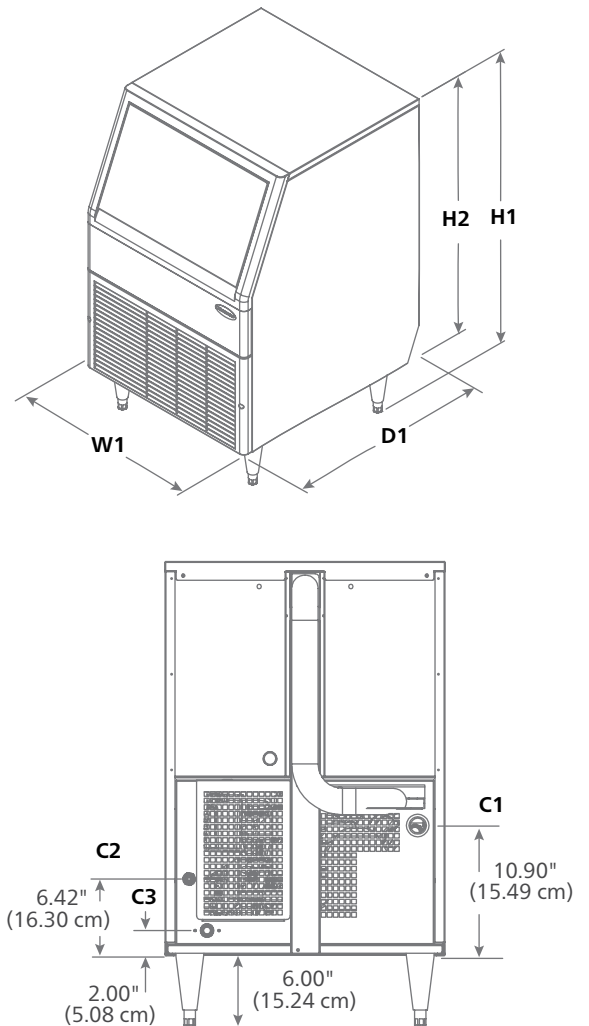

ENERGY STAR and the ENERGY STAR mark are registered trademarks owned by the U.S. Environmental Protection Agency.
MAESTRO PLUS and MICRO CHEWBLET are trademarks of Follett LLC.
FOLLETT is a registered trademark of Follett LLC, registered in the US.
Follett reserves the right to change specifications at any time without obligation. Certifications may vary depending on country of origin.

Ice machine bin for foodservice