



## Welcome to Follett

Follett equipment enjoys a well-deserved reputation for excellent performance, long-term reliability and outstanding after-the-sale support. To ensure that this equipment delivers that same degree of service, review this guide carefully before you begin your installation.

Should you need technical help, please call our Technical Service group at (877) 612-5086 or (610) 252-7301.

Please have your model number, serial number and complete and detailed explanation of the problem when contacting Technical Service.

## Getting Started

After uncrating and removing all packing material, inspect the equipment for concealed shipping damage. All freight is to be inspected upon delivery. If visible signs of damage exist, please refuse delivery or sign your delivery receipt "damaged." Follett Customer Service must be notified within 48 hours. Wherever possible, please include detailed photos of the damage with the original packaging so that we may start the freight claim process.



## CAUTION!

### ▪ CALIFORNIA PROPOSITION 65

- This product contains chemicals known to the state of California to cause cancer and birth defects or other reproductive harm. [www.P65warnings.CA.gov](http://www.P65warnings.CA.gov)
- Your product contains R600a (Isobutane) which is a flammable hydrocarbon. It is safe for regular use. Do not use sharp objects to expedite defrosting. Do not service without consulting the “R600a specifications” section included in the User Guide. Do not damage the refrigerant circuit.
- This equipment is to be installed with adequate backflow protection to comply with applicable federal, state, and local codes.
- Do not tilt unit further than 30° off vertical during uncrating or installation.
- Dispenser bin area contains mechanical, moving parts. Keep hands and arms clear of this area at all times. If access to this area is required, power to unit must be disconnected first.
- This appliance is not suitable for installation in an area where a water jet could be used.
- This appliance must not be cleaned by a water jet.
- User maintenance should not be done by children.
- Follett recommends a Follett water filter system be installed in the ice machine inlet water line (standard capacity #00130229, high capacity #00978957, carbonless high capacity #01050442).
- Prior to operation clean the dispenser in accordance with instructions found in this manual.
- Do not block air intake or exhaust.
- This appliance should be permanently connected by a qualified person in accordance with application codes.
- A qualified person shall provide a readily accessible disconnect device incorporated into the fixed wiring.
- If the supply cord is damaged, it must be replaced by the manufacturer, its service agent or similarly qualified persons in order to avoid a hazard.
- This appliance can be used by children aged 8 years and above and persons with reduced physical, sensory, or mental capabilities, or lack of experience and knowledge if they have been given supervision or instruction concerning use of the appliance in a safe way and understand the hazards involved. Children should be supervised to ensure that they do not play with the appliance.
- This appliance is designed for commercial use.
- **WARNING!** To avoid a hazard due to instability of the appliance, it must be fixed in accordance with the instructions.
- Warranty does not cover exterior or outside installations.
- To reduce risk of shock, disconnect power before servicing.
- Connect to potable water supply only.
- Ice is slippery. Maintain counters and floors around dispenser in a clean and ice-free condition.
- Ice is food. Follow recommended cleaning instructions to maintain cleanliness of delivered ice.

## Before You Begin

If needed, the serial number of your dispenser can be found by opening the door and locating the serial number label at the top right inside of the machine.

**Note: For indoor use only. Designed for commercial use. Follett is not able to provide in-house services for residential installations.**

### Model configurations

Ice storage capacity	Height	Filter <sup>1</sup>	Drain Pump	Item number
30 lb (13.6 kg)	34.12" (86.7 cm)	No	Yes	UCD100A30-NF
		Yes	Yes	UCD100A30-CF
	32.00" (81.3 cm) for ADA applications	No	Yes	UCD100A30ADA-NF
		Yes	Yes	UCD100A30ADA-CF

<sup>1</sup> Internal filter is a 5 micron particle and carbon filter.

# Specifications

## Dimensions

	Width	Depth	Height*	Unit Shipping Weight
UCD100A30-NF UCD100A30-CF	14.96" (38.0 cm)	24.38" (61.9 cm)	34.12" to 35.12" (86.7 cm to 89.2 cm)	101 lb (45.8 kg)
UCD100A30ADA-NF UCD100A30ADA-CF	14.96" (38.0 cm)	24.38" (61.9 cm)	32.00" to 33.00" (81.3 cm to 83.8 cm)	101 lb (45.8 kg)

\* Leveling legs, adjustable up to 0.25" (6.4 mm).

## Ambient Information



### CAUTION!

*This unit is for indoor use only. Designed for commercial use. Follett is not able to provide in-house services for residential installations.*

	Maximum*	Minimum*
Air Temperature†	100 F (38 C)	50 F (10 C)
Water Temperature	90 F (32.2 C)	40 F (4.5 C)
Water Pressure	70 psi (483 kpa)	10 psi (69 kpa)
Relative Humidity	55% at 78 F (25.5 C)	

\* Use outside of these limitations is misuse and will void warranty.

† Best performance is achieved between 80 F (27 C) and 50 F (10 C).

## Plumbing

- Water Inlet: 1/4" compression
- 3/8" braided drain hose (8' (2.4 m) provided)
- Water shut-off recommended within 5 ft (1.5 m) of dispenser
- This equipment is to be installed with adequate backflow protection to comply with applicable federal, state, and local codes.

## Water



### **WARNING!**

*Connect to potable water supply only.*

- Water Mineral Content:
  - TDS: greater than 5 ppm (mg/l) but less than 400 ppm (mg/l)
  - Hardness: Less than 200 mg/l (12 gpg)
- Not recommended for use with softened water
- Ingress Protection (IP) rating: IPX0 (no protection)

## Clearances

- Do not obstruct front grille air flow
- 2.00" (5.08 cm) behind

## Electrical

- 115 V, 60 Hz, 1 phase, 2A.
- Connect to dedicated 15 amp circuit, fuse or breaker.
- 6' (1.8 m) cord with 90° rounded type B plug.
- Must be grounded - requires 3-prong outlet. Do not remove ground.
- A GFCI (ground fault circuit interrupter) is usually not required for fixed location appliances and is not recommended for your unit because it could be prone to nuisance tripping.

## Refrigeration



### **WARNING!**

*Do not damage the refrigerant circuit. Refrigerant can cause personal injury and/or damage dispenser.*

- Refrigerant
  - R600a – 1.59 ounces (45 grams)

# Tempo Detailed Drawing

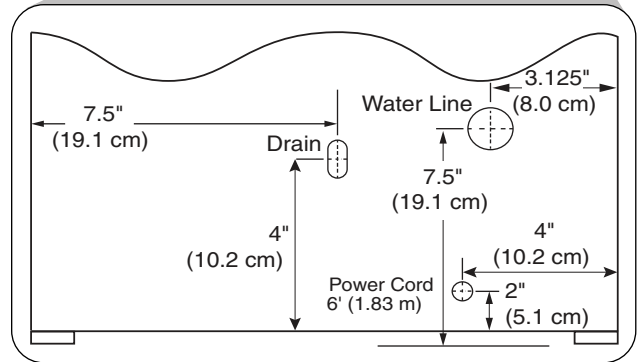
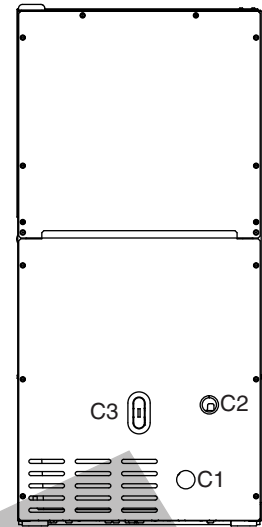
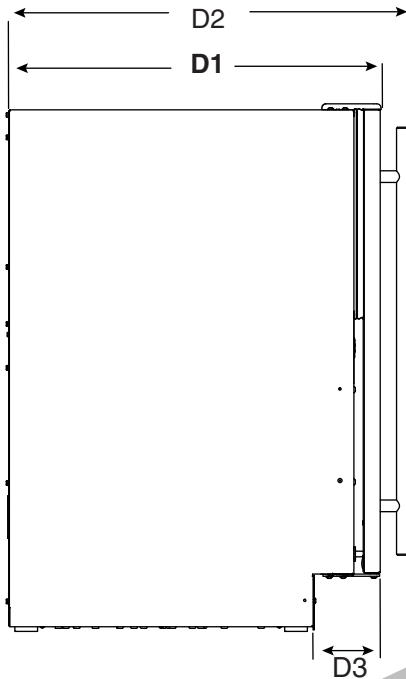
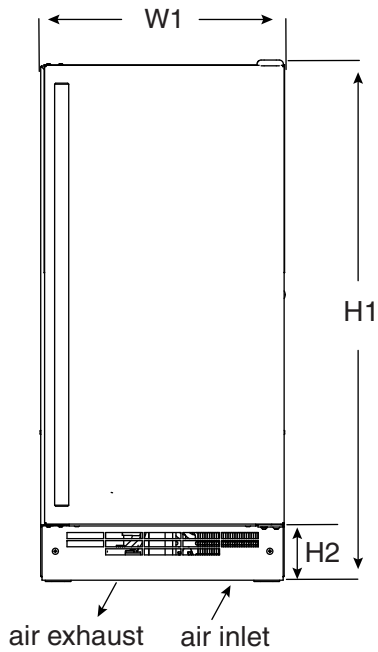

<b>W1</b> Width	14.96" (38.0 cm)
<b>D1</b> Depth without handle	22.56" (57.3 cm)
<b>D2</b> Depth including handle	24.38" (61.9 cm)
<b>D3</b> Kick recess depth	3.88" (9.86 cm)
<b>H1</b> Height – Standard model	34.12" to 35.12" (86.7 cm to 89.2 cm)
<b>H1</b> Height – ADA model	32.00" to 33.00" (81.3 cm to 83.8 cm)
<b>H2</b> Kick recess height	3.50" (8.89 cm)
Ventilation clearance	Do not obstruct front grille air flow
Service clearance	2.00" (5.08 cm) behind

<b>C1</b> 115 V/60/1 electrical	2 amps. Connect to dedicated 15 amp circuit, fuse or breaker. 6' (1.8 m) cord with 90° rounded type B plug.
<b>C2</b> Water inlet	1/4" compression
<b>C3</b> Drain	3/8" braided drain hose (8' (2.4 m) provided)

## Site Preparation

Your product has been designed for either freestanding or built-in installation. When built-in, your unit does not require additional air space for top, sides, or rear. However, the front grille must NOT be obstructed, and clearance is required for an electrical connection in the rear.

Unit can NOT be installed behind a closed cabinet door. If you would like to align the face of the unit with other adjacent cabinet doors, you may need to alter the wall just behind the drain connection on the unit to accommodate the drain.

**NOTE: To meet sanitary requirements in some areas, units must be built-in.**

## Cutout Dimensions

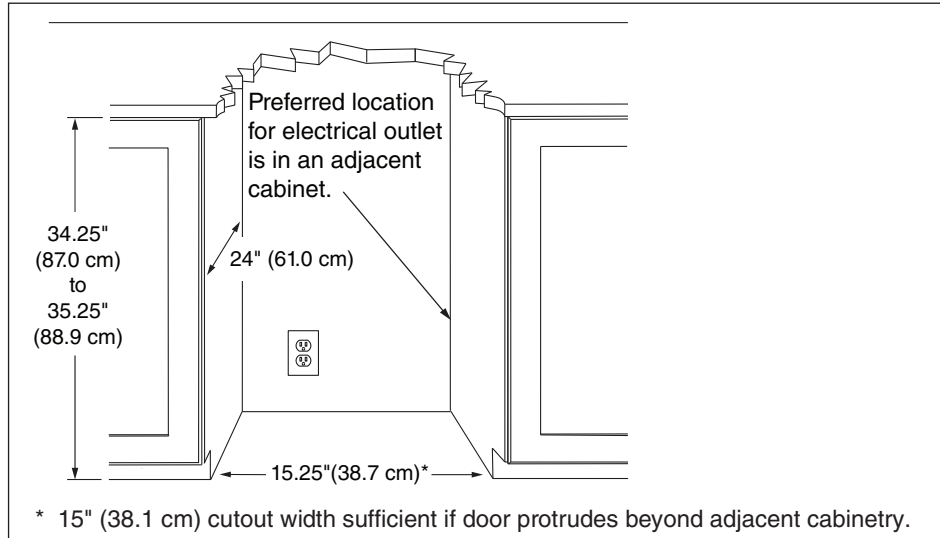

## Installation



### CAUTION!

*No service or maintenance should be performed until the technician has thoroughly read this service manual. Except for routine cleaning and sanitizing, only qualified technicians should attempt to service or maintain this equipment.*

- This equipment is to be installed with adequate backflow protection to comply with applicable federal, state, and local codes.
- The water pressure should be between 10 psi (69 kpa) and 70 psi (483 kpa).
- The water line MUST have a shut-off valve in the supply line.
- The water line should be looped into 2 coils. This will allow the unit to be removed for cleaning and servicing.
- Make certain that the drain and water line are not pinched or damaged during installation.
- A clearance of at least 3" (7.6 cm) is required behind the dispenser for electrical connection, and drain.
- Use caution when handling back panel. The edges could be sharp.

**NOTE: To meet sanitary requirements in some areas, installer must leave sufficient length (waterline, drain line, power cord) to permit the equipment to be moved for cleaning. Turn off water supply and disconnect electrical supply to product prior to attempting installation.**

1. Remove the back panel.
2. Thread water line through back panel hole (with bushing).
  - The water valve uses a standard 1/4" (6.35 mm) compression fitting. Water line not included.
    - The water line should be looped into 2 coils. This will allow the unit to be removed for cleaning and servicing. Make certain that the tubing is not pinched or damaged during installation.
3. Locate water valve inlet and connect to valve.
4. Turn on water supply and check for leaks.
5. Reinstall back panel.
6. The maximum lift for the drain pump is 10 feet. This must be done as close to the rear of the unit as possible.

### Door Swing

1. 2.25" (57 mm) clearance is recommended from wall on hinge side to allow the door to open 90°.
2. Units have a zero clearance when installed adjacent to cabinets.

Fig. 1

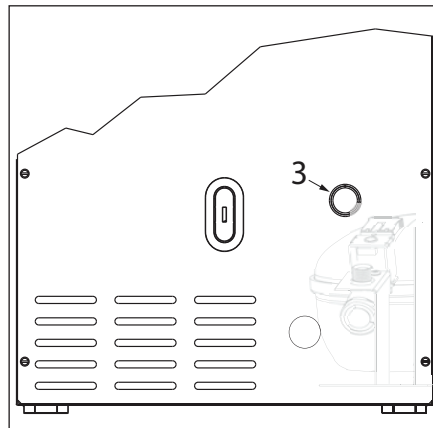

Fig. 2

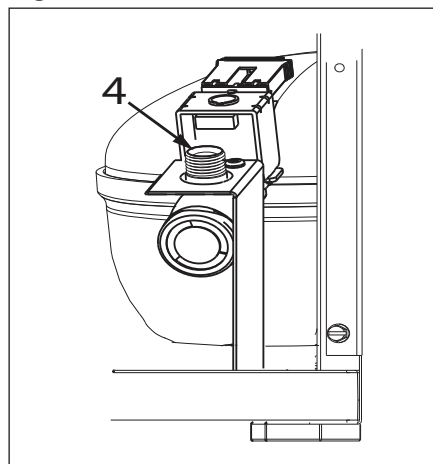
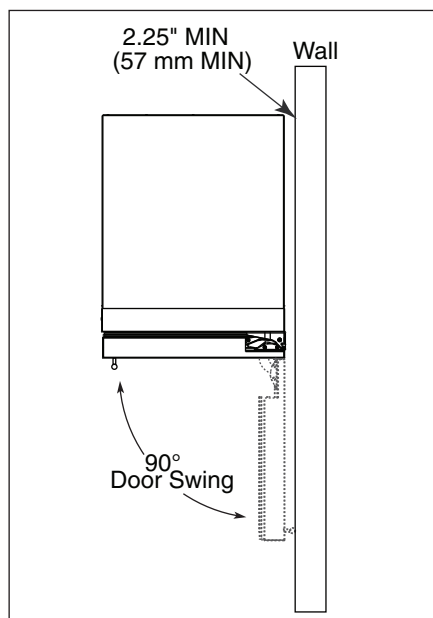

Fig. 3





## Hinge Cover

Hinge cover included with the literature bag is optional.

1. Press hinge cover squarely over hinge.

Fig. 4

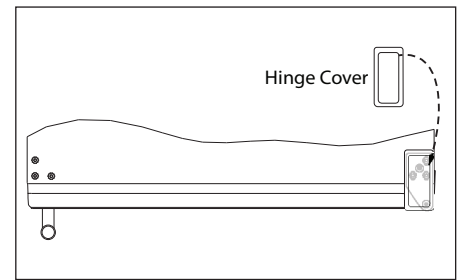

## To Reverse the Door (if required)

### Remove top hinge and door:

1. Hold door to keep it from falling.
2. Remove top hinge from cabinet using a Torx T-25 screwdriver to remove three screws. Set aside and save.
3. Remove door by tilting forward and lifting door off bottom hinge. Retain shoulder washers; they will be reused.
4. Remove three screws from hinge holes on the opposite side. Reinstall into holes where the hinge was removed.

Fig. 5

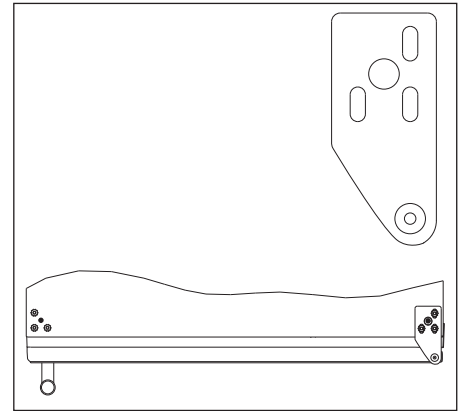
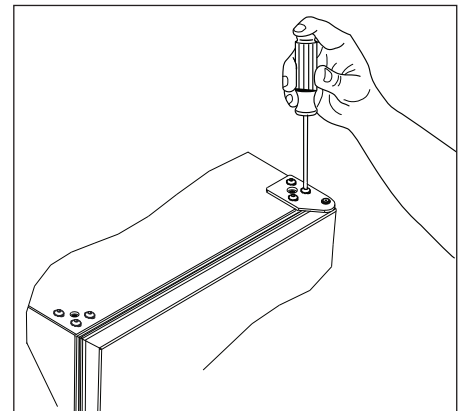

Fig. 6



### Remove Bottom Hinge

1. Remove bottom hinge from cabinet using a T-10 TORX screw driver to remove three screws.
2. Remove corresponding screws on opposite side of cabinet. On some models there may be a nut behind one or both screws on either side.

Fig. 7

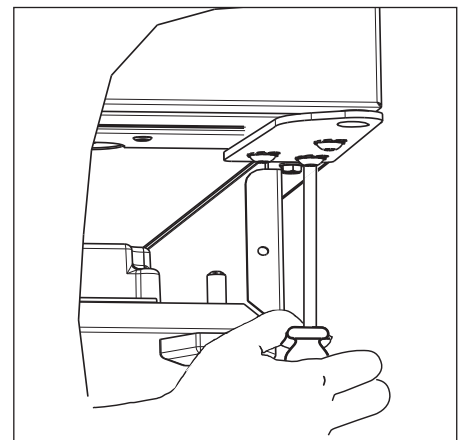

### Install Bottom Hinge

1. Install two or three screws, depending on model. Replace nuts if used.

Fig. 8

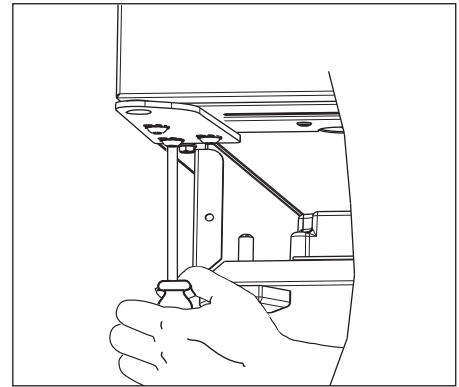

### Prepare Door for Reinstallation

1. Remove gasket.
2. Rotate gasket 180° and press firmly into the gasket channel, starting at the corners.
3. Rotate door 180° to reverse.

### Install Top Hinge and Door

1. Install hinge with longer straight edge aligned to outside edge of cabinet. Do not tighten
2. Lift the door on to the bottom hinge.
3. Align edge of the hinge with the outer edge of the unit.
4. Tighten three hinge screws.

Fig. 9

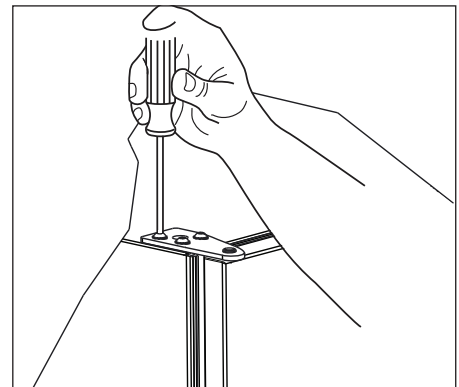

**Align and adjust the door:** Align and adjust the door (see DOOR ALIGNMENT AND ADJUSTMENT).

### Door Alignment and Adjustment

Align and adjust the door if it is not level or is not sealing properly. If the door is not sealed, the unit may not cool properly, or excessive frost may form in the interior.

Properly aligned, the door's gasket should be firmly in contact with the cabinet all the way around the door (no gaps). Carefully examine the door's gasket to ensure that it is firmly in contact with the cabinet. Also make sure the door gasket is not pinched on the hinge side of the door.

#### To align and adjust the door:

1. Gently pry off hinge cover from top of unit.
2. Loosen (do not remove) top and bottom hinge screws using a Torx T-25 screwdriver.
3. Align door squarely with cabinet.
4. Make sure gasket is firmly in contact with cabinet all the way around the door (no gaps).
5. Tighten bottom hinge screws.
6. Tighten top hinge screws and replace hinge cover.

## Leveling Information

### Installation Tip

**Note:** If the room floor is higher than the floor in the cutout opening, adjust the rear legs to achieve a total unit rear height of 1/10" (2.54 mm) less than the opening's rear height. Shorten the unit height in the front by adjusting the front legs. This allows the unit to be gently tipped into the opening. Readjust the front legs to level the unit after it is correctly positioned in the opening.

1. Use a level to confirm the unit is level. Level should be placed along top edge and side edge as shown
2. If the unit is not level, adjust the legs on the corners of the unit as necessary.

**NOTE:** To meet sanitary requirements in some areas, units are supplied with gliders so that unit can be removed easily for cleaning and will have minimal adjustment.

3. Confirm the unit is level after each adjustment and repeat the previous steps until the unit is level.

## Set in Place

1. Plug in the power/electrical cord.
2. Gently push the unit into position. Be careful not to entangle the cord or water and drain lines, if applicable.
3. Re-check the leveling from front to back and side to side. Make any necessary adjustments. The unit's top surface should be approximately 1/8" (3 mm) below the countertop.
4. Install the anti-tip bracket.
5. Remove interior packing material and wipe out the inside of the unit with a clean, water-dampened cloth.
6. Clean the unit prior to first use (see the Cleaning section that follows).

Fig. 10

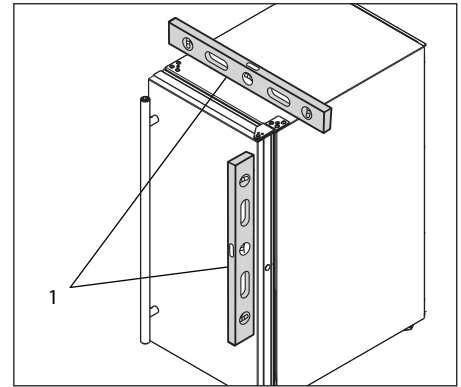
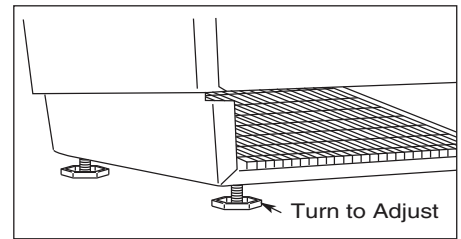
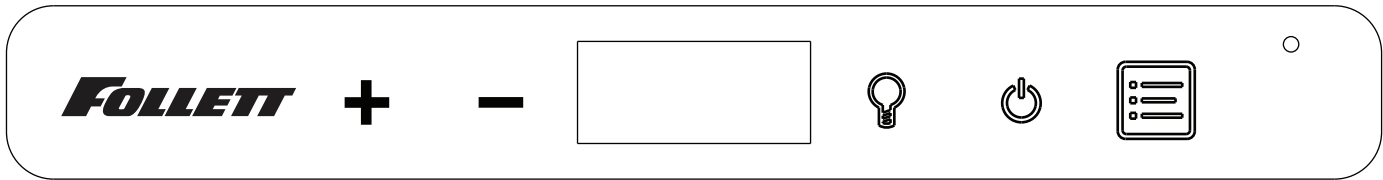





Fig. 11



## Control Operation





Function	Command	Notes
ON/OFF	Press  and release	Unit will immediately turn ON or OFF
Enable Sabbath Mode	Press  and hold for 5 s and release	The °F/°C symbol will flash briefly after 5 s. Interior light and display will go dark and remain so until user resets mode - unit continues to operate
Disable Sabbath Mode	Press  and release	Display and interior light return to normal operation
Clean Mode	See “Cleaning” section	

## Door Alert Notification

- When the door is left open for more than 30 minutes:
  - Ice production will cease
  - A tone will sound for several seconds every minute
  -  will appear in display
- Close door to silence alert and reset (Ice production will resume if bin sensor is not satisfied).

## First Use

Initial startup requires no adjustments. See CONTROL OPERATION section for more details.

- Follett recommends discarding the ice produced during the first two to three hours of operation to avoid possible dirt or scale that may dislodge from the water line.
- When plugged in, the unit will begin operating under the factory default settings. If the unit was turned off during installation, simply press  and the unit will immediately switch on. To turn the unit off, press  and release.

## Ice

The Nugget Ice Machine produces cylindrical bits of compressed ice approximately 3/4" x 1/2".

Ice is produced until the machine senses the bin is full. As ice slowly melts in the bin, the level of ice drops and ice production resumes. This ensures a constant supply of fresh ice is always available.

## Cleaning

This ice machine has an automatic clean alert function.

The control will indicate **CL** in the display, approximately every six months with normal use, reminding you to clean your unit. When **CL** is displayed, ice production will continue. Depending on water conditions, more frequent cleaning may be necessary. Cleaning removes lime scale, other mineral deposits, and sanitizes the machine. Poor ice quality and reduced ice output are signs that cleaning is necessary. If the machine consistently requires more frequent cleaning, consult a plumber to test the water quality and recommend appropriate treatment.

Under normal conditions, cleaning should be done when the display shows **CL**. You may initiate a cleaning cycle at any time by pressing and holding the clean button for 10 seconds.

**CL** will appear in the display indicating the start of the cleaning process.

You may override **CL** in the display without cleaning by pressing and holding the **+**, **-**, and **Lightbulb** buttons for 10 seconds. **ICE** will scroll in the display and the cleaning reminder (**CL**) will be reset for another approximate six month cycle. Failure to clean may reduce the quality and quantity of ice produced. Once the clean cycle begins, it can be canceled by pressing **Power** three times. Press **Power** once more to start making ice. The clean cycle will automatically cancel if user fails to activate control at steps 7, 12, and 20 within 2 hours.

### Required for cleaning:

- Hose and funnel – provided with unit
- Bucket and cleaning sponge
- Clean potable water
- SafeCLEAN Plus™ Cleaner
- Water filter

## Cleaning Process (approximate time: 40 minutes)

### **WARNING!**



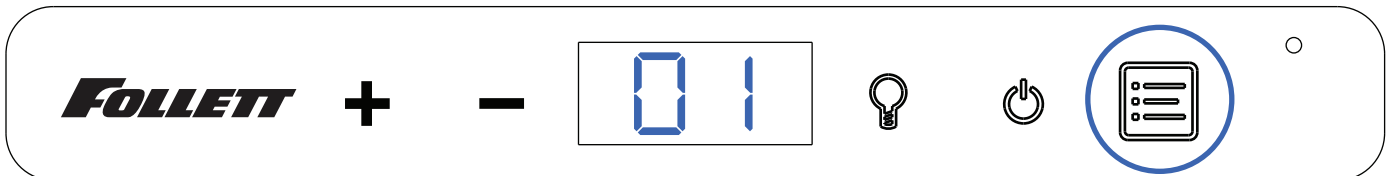



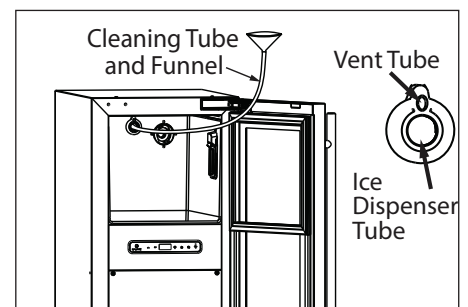

- For protection, rubber gloves and safety goggles (and/or face shield) should be worn when handling SafeCLEAN Plus™.
- Do not use bleach, it will damage the dispenser.



1. Press and hold  for 5 to 10 seconds.
2. **CL** will appear in the display
3. Remove access shield
4. Remove all ice in bin
5. Remove any ice protruding from the ice dispenser tube
6. Insert the end of the cleaning tube (**Fig. 12**) into the ice dispenser; slowly pour in approximately 1 quart of hot potable water (100 F minimum). This will melt ice inside the dispenser tube. It is normal for some water to flow out of the ice dispenser tube and exit from the vent tube while pouring. Omit this step if no ice is in the ice dispenser tube.

**Fig. 12**



7. Press and release .
8.  will appear in the display.
9. Mix 4 ounces of SafeCLEAN Plus™ with 2 quarts of hot potable water (100 F minimum).
10. Wait until  appears in the display.
11. Using the funnel and cleaning tube, slowly pour 3/4 of the cleaning solution into the dispenser tube. Air and some water will exit the vent tube. Remove cleaning tube.
12. Press and release .
13.  will appear in the display.
14. The machine will circulate the solution, cleaning and sanitizing the internal components, for approximately 20 minutes.
15. While the machine is circulating the cleaning solution, use 1/2 of the remaining cleaning solution and a sponge to wipe down the inside of the ice bin and scoop. Rinse thoroughly with clean potable water.
16. When  appears in the display, 3 soft tones will sound, indicating the cleaning phase is complete.
17. Remove water filter by rotating approximately 1/4 turn counterclockwise.
18. Use the remaining cleaning solution to wipe the manifold and surrounding area (**Fig. 13**). Rinse with clean potable water.
19. Using the hose and funnel, slowly pour 1.5 quarts (48 oz.) of clean, potable water into the ice dispenser tube. Air and some water will exit the vent tube.
20. Install new water filter.
21. Press and release .
22.  will appear in the display.
23. Reinstall shield and close door - no further action is required.
24. The machine will circulate water and perform a series of final rinses for approximately 15 minutes.
25. The unit will resume making ice - indicated by 3 soft tones and **ICE** scrolling in the display. Discard ice collected during first 10 minutes.

**Fig. 13**

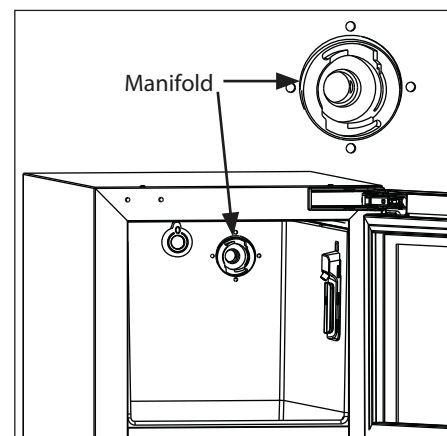

### User Interface and Exterior Cabinet

26. Plastic parts, including the user interface, can be cleaned with a non-abrasive glass cleaner. Clean stainless steel panels with stainless steel cleaner.

# Troubleshooting

## Before Calling for Service

If you think your product is malfunctioning, read the CONTROL OPERATION section to clearly understand the function of the control. If the problem persists, read the NORMAL OPERATING SOUNDS and TROUBLESHOOTING GUIDE sections below to help you quickly identify common problems and possible causes and remedies. Most often, this will resolve the problem without the need to call for service.

If your product needs service, please go to [www.U-Line.com](http://www.U-Line.com) and navigate to the Find a Servicer page to locate a U-Line Authorized servicer. If your product is in warranty please make sure to register it at [www.U-Line.com/u-lineregistration](http://www.U-Line.com/u-lineregistration). If you have any issues following this process you can contact the U-Line Corporation by phone at +1.800.779.2547

If you call, you will need your product Model and Serial Numbers. This information appears on the Model and Serial number plate located on the interior of your product, most often placed on the ceiling.

## Normal Operating Sounds

All models incorporate rigid foam insulated cabinets to provide high thermal efficiency and maximum sound reduction for its internal working components. Despite this technology, your model may make sounds that are unfamiliar. Normal operating sounds may be more noticeable because of the unit's environment. Hard surfaces such as cabinets, wood, vinyl or tiled floors and paneled walls have a tendency to reflect normal appliance operating noises. Listed below are common refrigeration components with a brief description of the normal operating sounds they make. NOTE: Your product may not contain all the components listed.

- Compressor: The compressor makes a hum or pulsing sound that may be heard when it operates.
- Evaporator: Refrigerant flowing through an evaporator may sound like boiling liquid.
- Condenser Fan: Air moving through a condenser may be heard.
- Running Water: As your unit continues to produce ice you will hear water flowing into the collection

<b>Problem</b>	<b>Possible Cause and Remedy</b>
Unit Does Not Operate. Electronic Display Blank.	No electrical supply. Plug unit in or check circuit breaker.
Display Showing Error Code	If display shows error "dr," check to make sure door is sealing correctly. Make sure to close door completely. If sealing the door does not clear the error, contact Follett.
Unit Develops Condensation on External Surfaces	The unit is exposed to excessive humidity. Moisture will dissipate as humidity levels decrease.
Poor Ice Quality	Unit may not be level. Check if unit is level. Ice maker system may be dirty. Clean the ice maker.
No Ice Production	Ensure water is being supplied to the unit. Verify the ice making unit is turned on.
Not Enough Ice	Ensure the condenser coil is clean and free of any dirt or lint build-up.
Water in Ice Bin	Drain may be restricted, ensure drain is free of foreign debris.

## Disassembly - Access to Evaporator

1. Disconnect power from the dispenser.
2. Turn off water supply to dispenser.
3. Empty all ice from the unit and discard.
4. Tilt the unit and remove the six screws from the bottom of the chassis.

Fig. 14

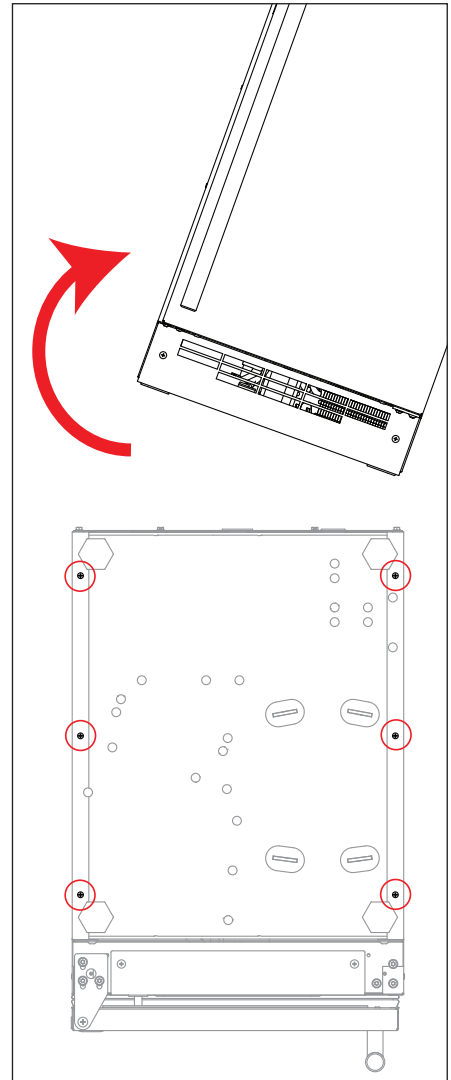

5. Remove the two screws holding the kickplate. Remove kickplate.

Fig. 15

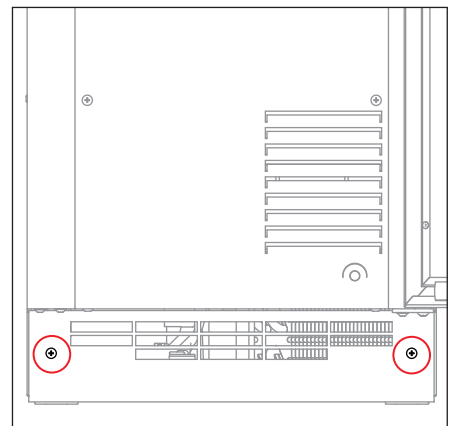



6. Remove 2 thumbscrews (**Fig. 16.1**) and 4 Phillips-head screws (**Fig. 16.2**) holding front panel. Remove front panel.
7. Remove the two spade connections from the door switch (**Fig. 16.3**) at the front of the unit.

**Fig. 16**

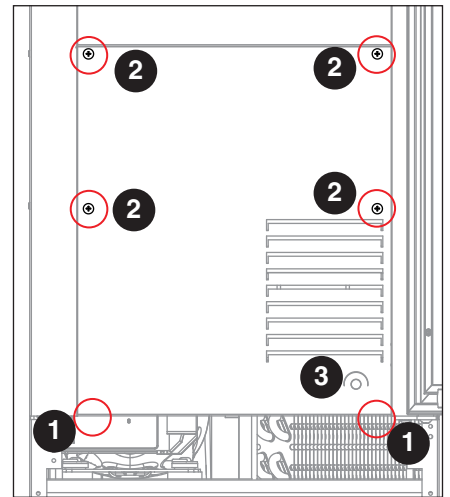

8. Remove the two screws securing the control box at the front of the unit.
9. Carefully pull the control box outside the front of the unit.

**Fig. 17**

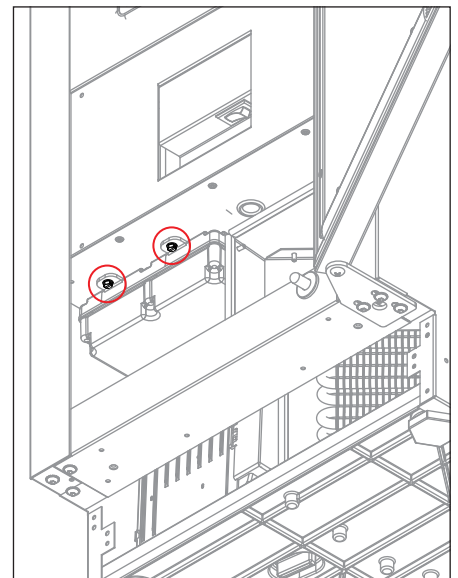

10. Remove the 6 screws holding the lower back panel. Remove panel.
11. Remove the 8 screws holding the upper back panel. Remove panel.

**Fig. 18**

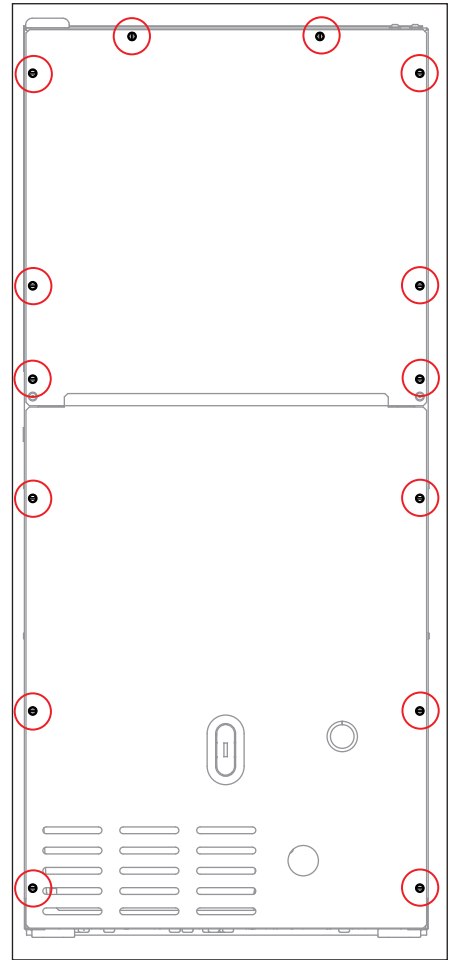

12. Using a 1/4" socket with an extension or a long-handled flat head screwdriver, remove the two screws located inside the back of the unit.

**Fig. 19**

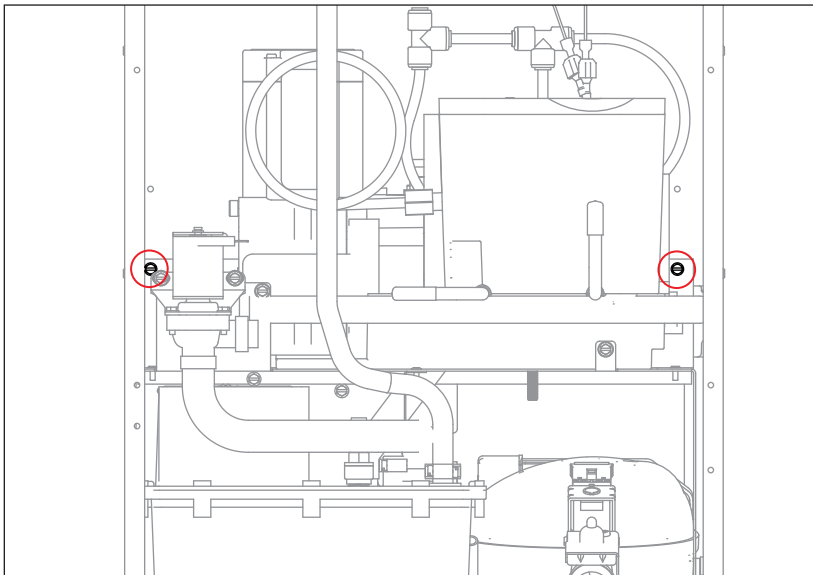

13. Disconnect the vent tube.

**Fig. 20**

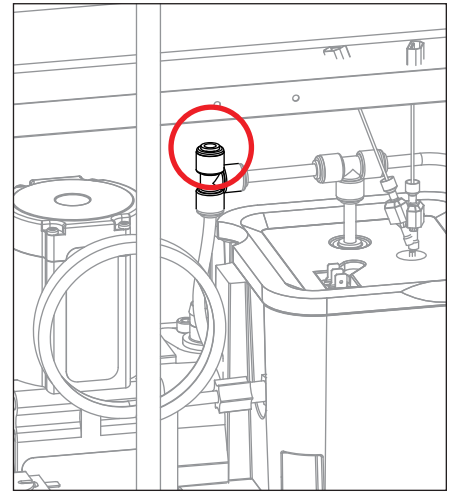

14. Loosen the hose clamp and disconnect the ice transport tube from the nozzle.

**Fig. 21**

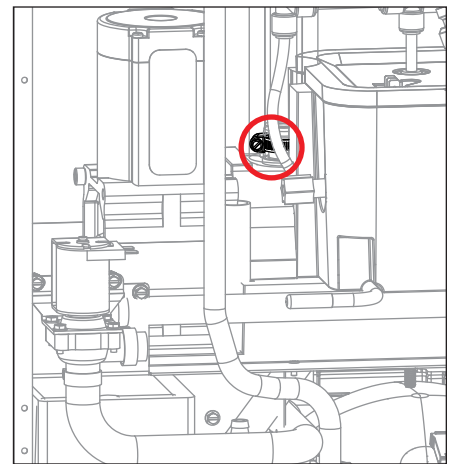

15. Disconnect the filter line.

**Fig. 22**

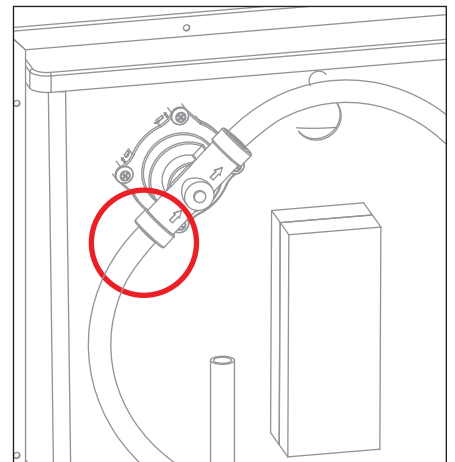

16. Disconnect the two electrical connections.

Fig. 23

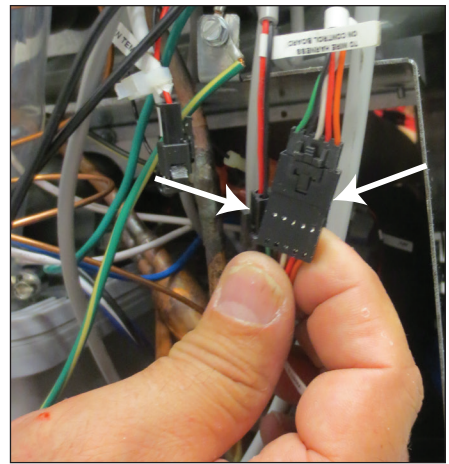

17. From front of unit, reach in and loosen the hose clamp at the top of the elbow and then disconnect the drain line.

18. Place the electrical box back inside the unit.

Fig. 24

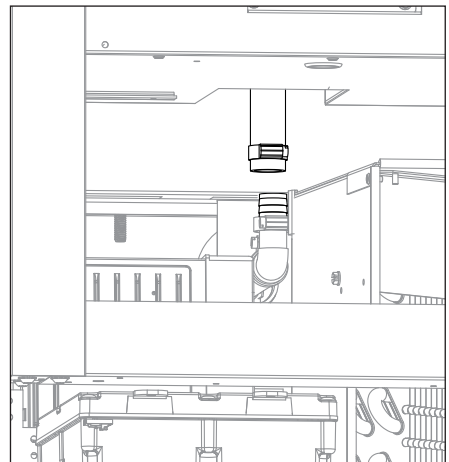

19. Pull out on both side of the unit to free the side panels from the evaporator assembly.

20. Carefully slide out the evaporator assembly just until the gear motor is accessible - be careful of electrical connections.

Fig. 25

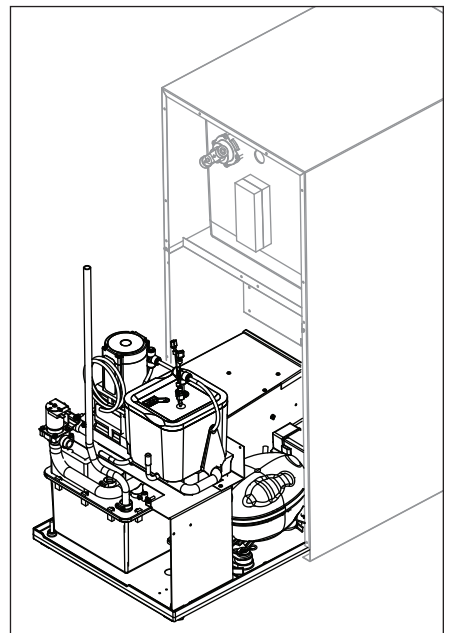

## Evaporator Disassembly

1. Disconnect power from the dispenser.
2. Turn off water supply to dispenser.
3. Remove the screw securing the start capacitor.
4. Unplug the gear motor (three connectors) **(Fig. 26)**.
5. Remove ground screw connection. ?

6. Remove gear motor:
  - Remove M6 allen screw, retainer, spacer and key **(Fig. 27.1)**.
  - Remove two M6x90 allen screws **(Fig. 27.2)**.
  - Pull gear motor from auger **(Fig. 27.3)**.
  - Remove main housing insulation **(Fig. 27.4)**.
7. Remove all traces of Petrol-gel from auger shaft.

8. Remove compression nozzle:
  - Remove M6 socket head allen screw **(Fig. 28.1)**.
  - Remove the insulation.
  - Remove compression nozzle retainer **(Fig. 28.2)**.
  - Remove compression nozzle **(Fig. 28.3)**.

Fig. 26

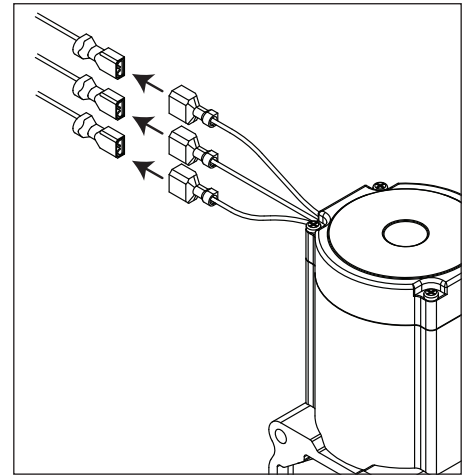

Fig. 27

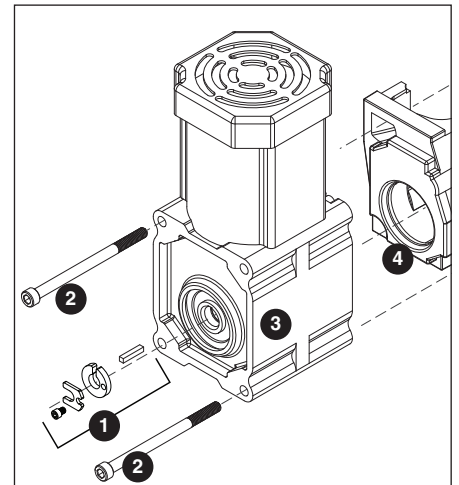
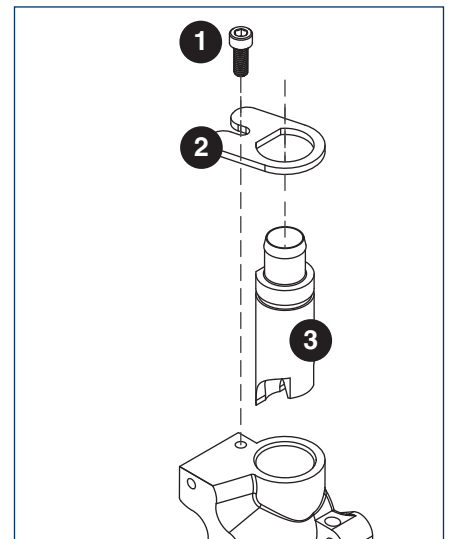

Fig. 28



9. Remove main housing:

- Disconnect vent line from T fitting (**Fig. 29.1**).

**Fig. 29**

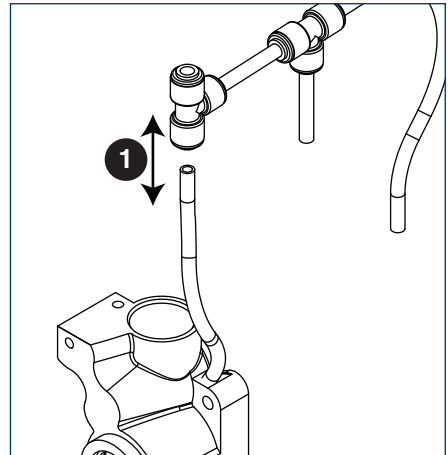

10. Remove three M6x25 socket head allen screws and vent tube clip (**Fig. 30.1**).

11. Remove main housing (**Fig. 30.2**).

**Fig. 30**

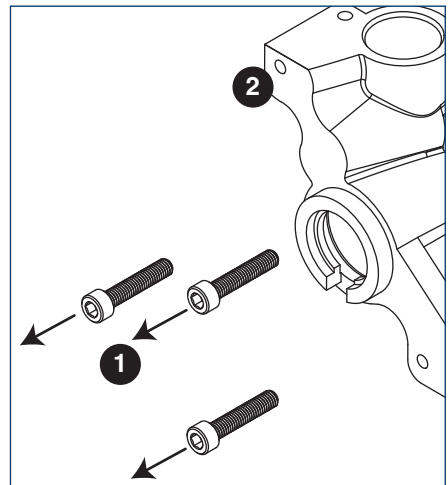

12. Remove and discard mating ring and seal (**Fig. 31.1**).

13. Carefully remove auger (**Fig. 31.2**).

**Fig. 31**

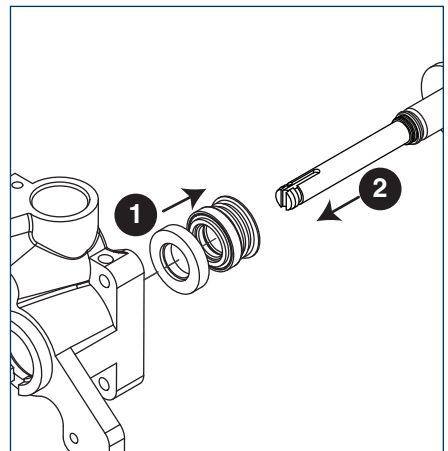

**WARNING!**

*Use caution when removing auger. The auger is very sharp - handle with care to avoid personal injury.*

## Evaporator Assembly

1. Remove and inspect main housing O-ring seal. Replace if damaged in any way.
2. Clean O-ring groove. Lubricate O-ring with Petrol-gel and reinstall.
3. Use cardboard disc to press new mating ring into main housing (**Fig. 32.1**).
4. Lube the shaft with liquid soap in the area shown (**Fig. 32.2**) and slip on seal and spring (**Fig. 32.3**).

**Note:** Do not touch the sealing surfaces with bare hands. Contact with bare skin will cause premature seal failure.

5. Install auger (**Fig. 32.4**).

**Fig. 32**

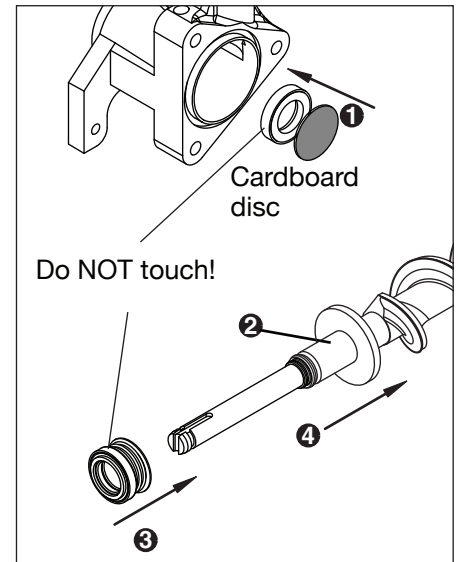

6. Install main housing:

- Slide main housing onto auger shaft (**Fig. 33.1**).
- Install three M6x25 allen screws (**Fig. 33.2**) and vent tube clip.
- Connect vent line to T fitting (**Fig. 33.3**).

**Fig. 33**

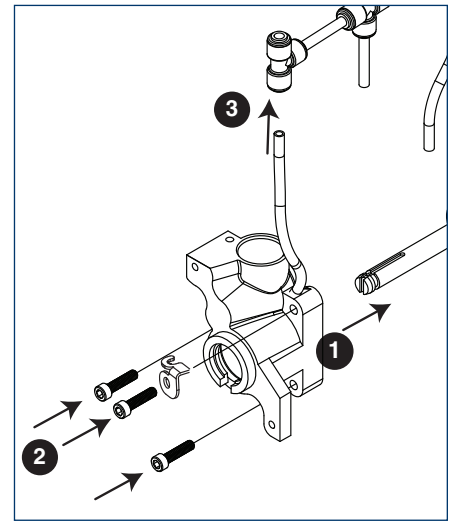

7. Install compression nozzle:

- Remove and inspect compression nozzle O-ring seal. Replace if damaged in any way.
- Clean O-ring groove. Lubricate O-ring with Petrol-gel and reinstall.
- Install compression nozzle (**Fig. 34.1**).
- Install compression nozzle retainer (**Fig. 34.2**).
- Install M6 socket head allen screw (**Fig. 34.3**).

**Fig. 34**

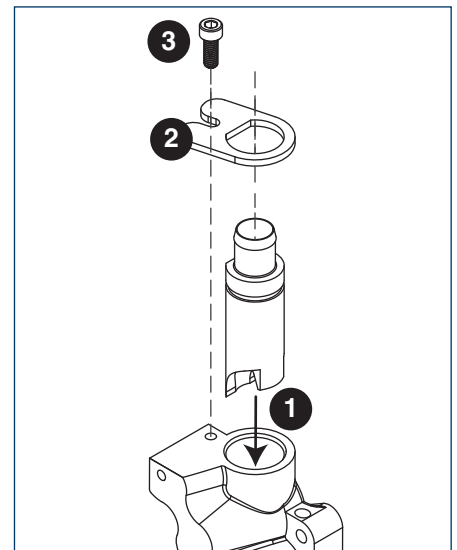

8. Install transport tube (**Fig. 35.1**).
9. Tighten hose clamp (**Fig. 35.2**).

**Fig. 35**

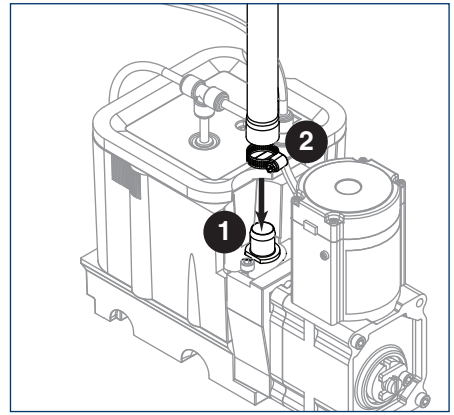

10. Install gear motor:
  - Install main housing insulation (**Fig. 36.1**).
  - Slide gear motor onto auger shaft (**Fig. 36.2**).
  - Install two M6x90 allen screws (**Fig. 36.3**).

**Fig. 36**

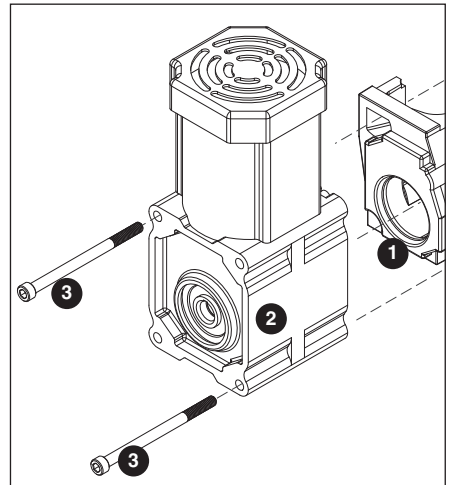

11. Use screwdriver to orient auger shaft to align with motor shaft keyway (**Fig. 37.1**).
12. Install key into keyway (**Fig. 37.2**).

**Fig. 37**

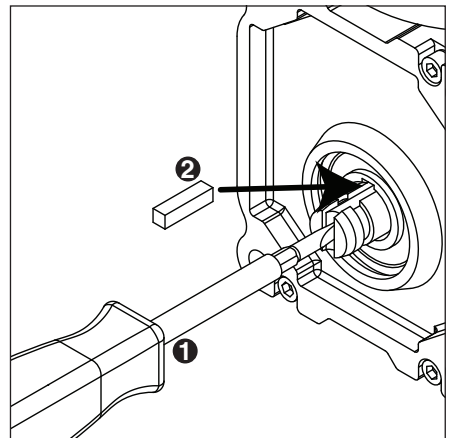



13. Install spacer, ensure that key is captured in slot (**Fig. 38.1**)

**Fig. 38**

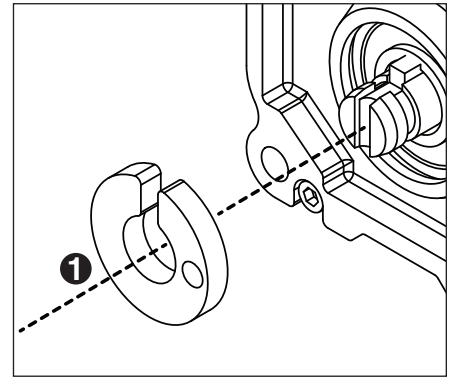

14. Insert screwdriver into groove of auger shaft and pry shaft outwards (**Fig. 39.1**).

15. Insert retainer into groove (**Fig. 39.2**), ensure that retainer is aligned with hole in spacer.

**Fig. 39**

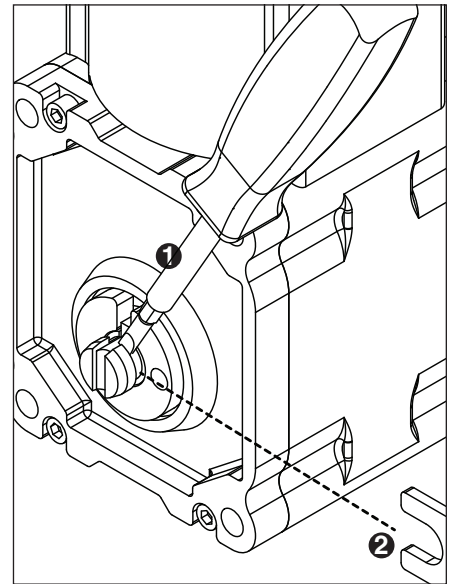

16. Install screw and tighten (**Fig. 40.1**).

**Fig. 40**

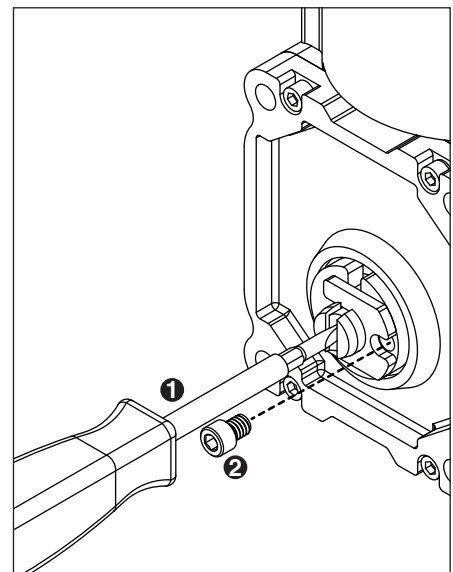

17. Plug in gear motor (**Fig. 41**).

- BLUE to BLUE
- BLACK to BLACK
- WHITE to WHITE
- Connect ground wire with ground screw.

**Fig. 41**

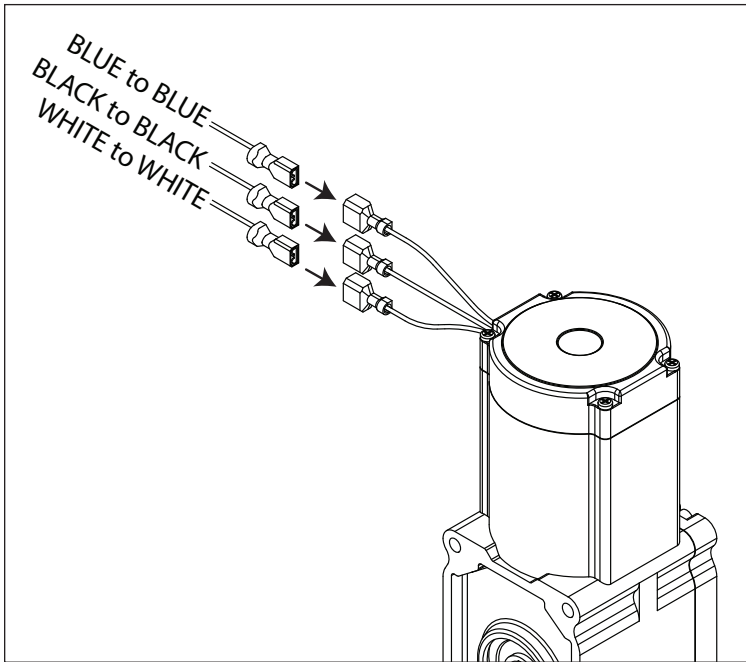

## Water Feed Schematic

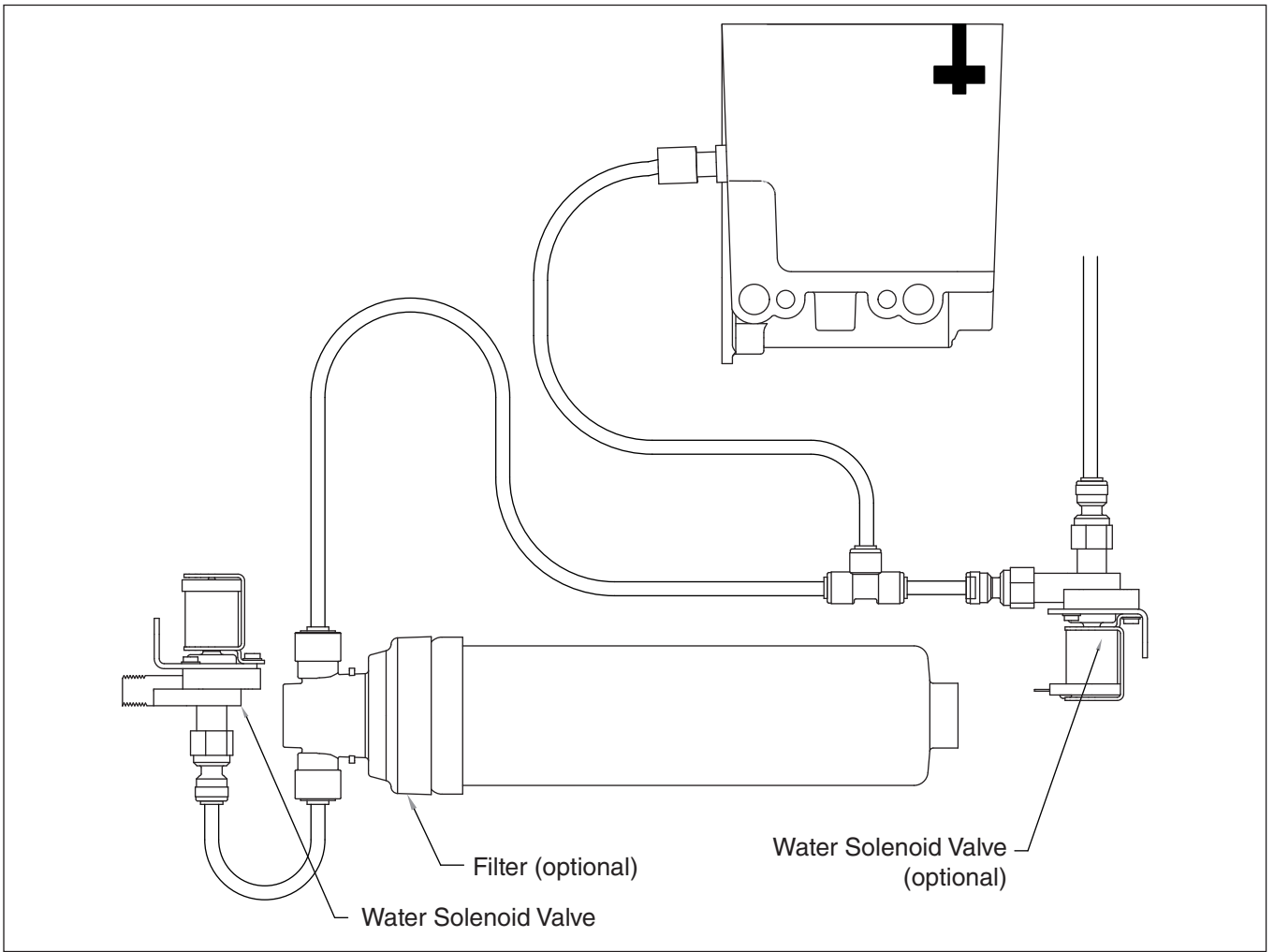

## Vent System Schematic

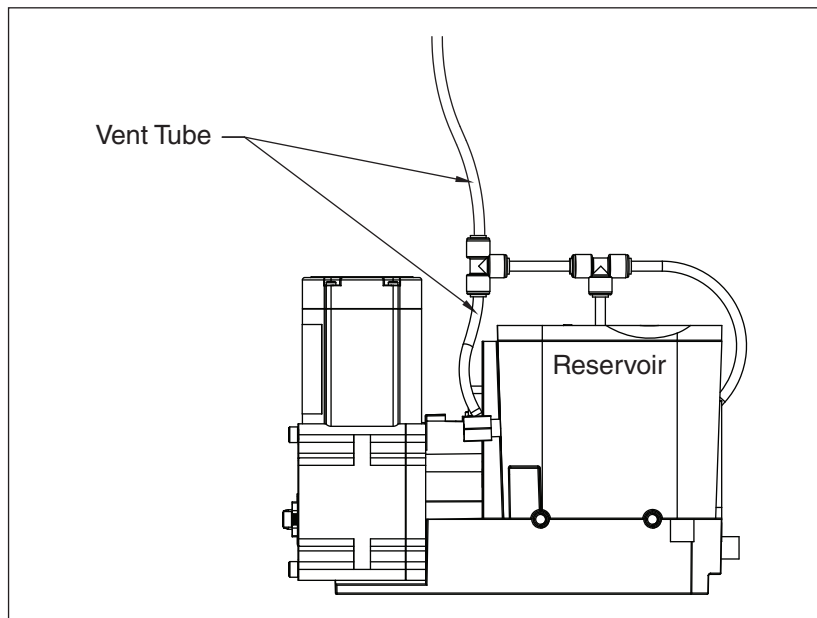

# Electrical Wiring Diagram

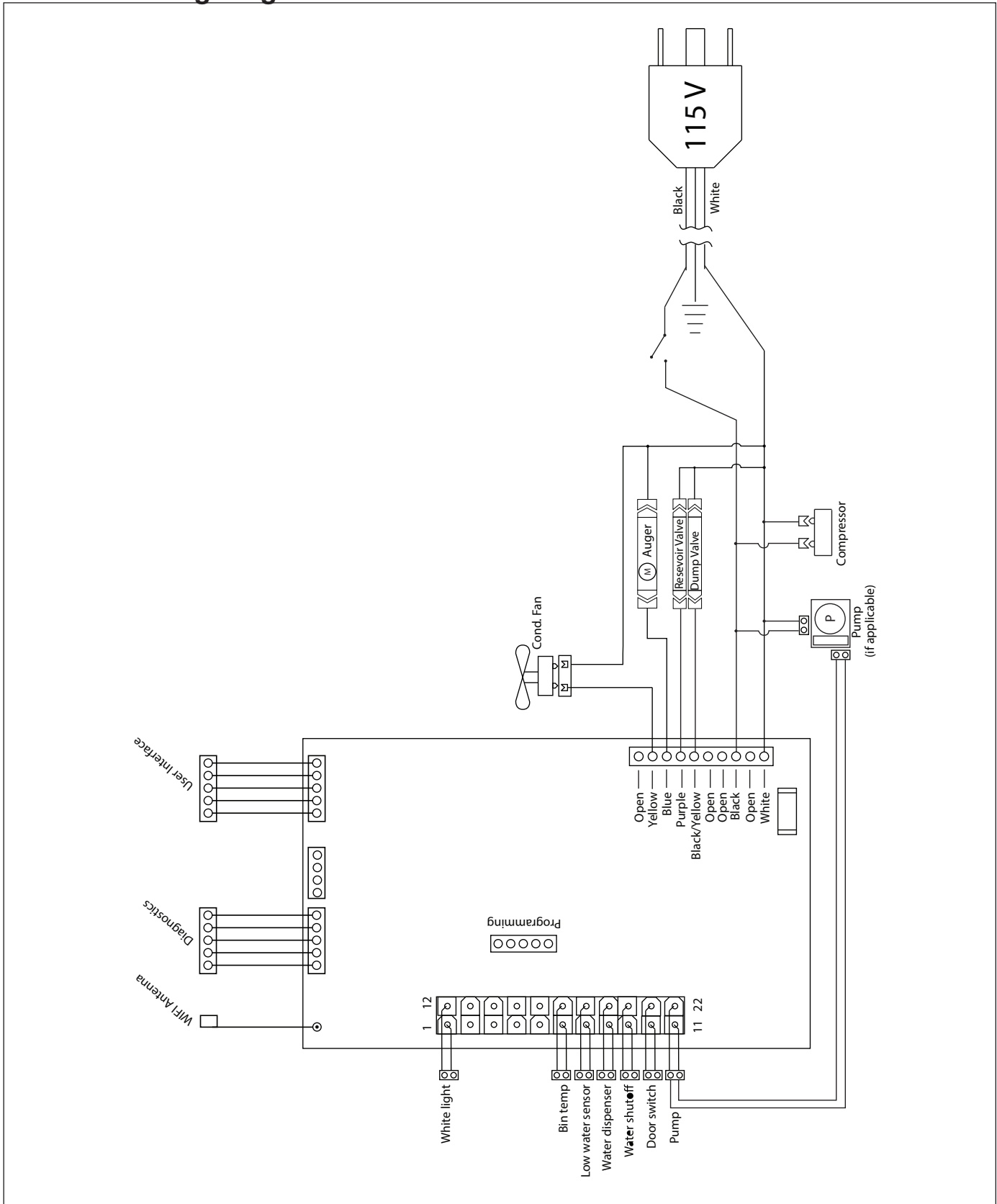

# Refrigeration Schematic

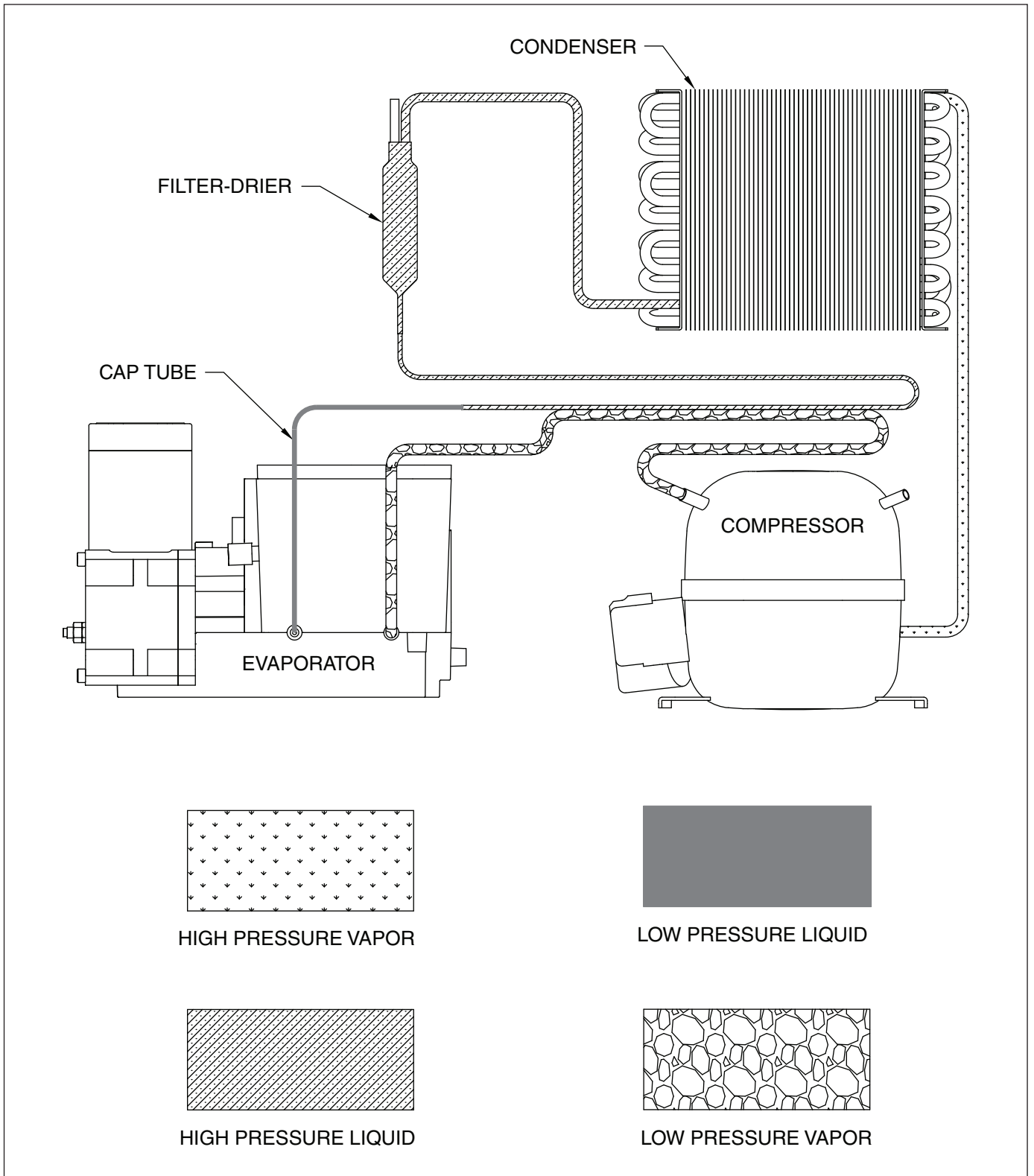

## Refrigeration System Diagnostic Guide

System Condition	Section Pressure	Suction Line	Compressor Discharge	Condenser	Capillary Tube	Evaporator	Wattage
<b>Normal</b>	Normal	Slightly below room temperature	Very hot	Very hot	Warm	Cold	Normal
<b>Overcharge</b>	Higher than normal	Very cold may frost heavily	Slightly warm to hot	Hot to warm	Cool	Cold	Higher than normal
<b>Undercharge</b>	Lower than normal	Warm-near room temperature	Hot	Warm	Warm	Extremely cold near inlet - Outlet below room temperature	Lower than normal
<b>Partial Restriction</b>	Somewhat lower than normal vacuum	Warm-near room temperature	Very hot	Top passes warm - Lower passes cool (near room temperature due to liquid)	Room temperature (cool) or colder	Extremely cold near inlet - Outlet below room temperature backing up	Lower than normal
<b>Complete Restriction</b>	In deep vacuum	Room temperature (cool)	Room temperature (cool)	Room temperature (cool)	Room temperature (cool)	No refrigeration	Lower than normal
<b>No Gas</b>	0 PSIG to 25'	Room temperature (cool)	Cool to hot	Room temperature (cool)	Room temperature (cool)	No refrigeration	Lower than normal

## Compressor Specifications

**⚠ DANGER!**

*Electrocution can cause death or serious injury.*

- Burns from hot or cold surfaces can cause serious injury. Take precautions when servicing this unit.
- Disconnect the power source.
- Do not stand in standing water when working around electrical appliances.
- Make sure the surfaces you touch are not hot or frozen.
- Do not touch a bare circuit board unless you are wearing an anti-static wrist strap that is grounded to an electrical ground or grounded water pipe.
- Handle circuit boards carefully and avoid touching components.
- To measure the start winding resistance, measure across the C and S pins.
- To measure the run winding resistance, measure across the C and R pins.
- Also check S to R and you should get the sum of the run and start windings.
- To ensure the windings are not shorted, check the S and R to ground.

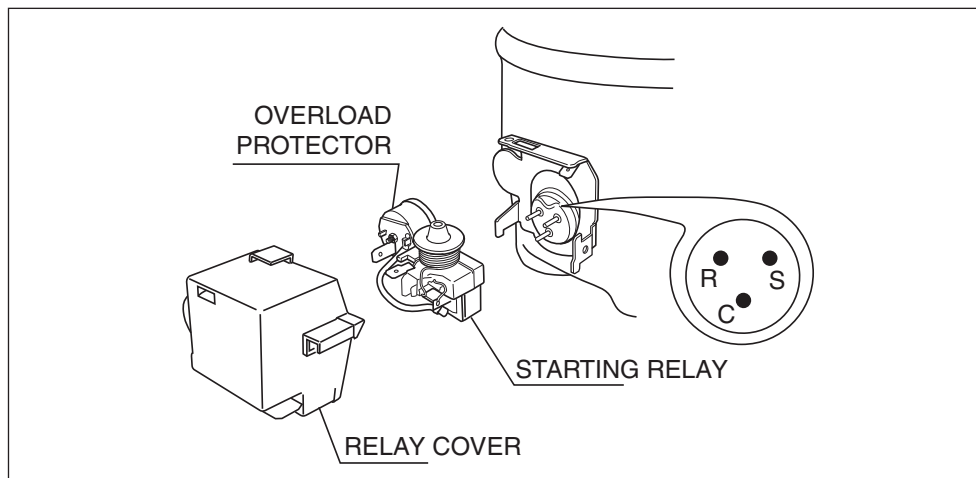

	<b>EMU30HSC</b>
Refrigerant	R134a
Voltage	115 VAC
Frequency	60 Hz
Run Cap	12 $\mu$ F/180 VAC
Start Winding	7.0 Ohm at 77°F
Run Winding	8.4 Ohm at 77°F
LRA	5.5 A
FLA	1.0 A
Starting Device	8EA14C
Overload	4TM197NFBYY-53

## Troubleshooting - Extended

### Specific Errors and Issues

The advanced diagnostic capabilities of the electronic controls utilized on the 1, 3, and 5 Class units allow for easy and thorough troubleshooting.

Navigation of the control is the key and is explained in the CONTROL OPERATION section of the manual, along with control button layout, control function descriptions, a service mode menu and service menu selection explanations.

Verification of temperature and thermistor performance can be identified by directly viewing thermistor readings in the service mode.

Component failure issues can be identified through service mode menu #20, "Component Testing." Individual components can be switched on and off to check for both proper function of a specific component and also delivery of supply voltage to the components through the relays and DC outputs located on the relay/power board.

### Normal Operating Sounds

All models incorporate rigid foam insulated cabinets to provide high thermal efficiency and maximum sound reduction for its internal working components. Despite this technology, your model may make sounds that are unfamiliar.

Normal operating sounds may be more noticeable because of the unit's environment. Hard surfaces such as cabinets, wood, vinyl or tiled floors and paneled walls have a tendency to reflect normal appliance operating noises.

Listed below are common refrigeration components with a brief description of the normal sounds they make.

**NOTE: Your product may not contain all the components listed.**

- Compressor: The compressor makes a hum or pulsing sound that may be heard when it operates.
- Evaporator: Refrigerant flowing through an evaporator may sound like boiling liquid.
- Condenser Fan: Air moving through a condenser may be heard.
- Water Valve: Running water and clicking as valve opens and closes.
- Ice Dropping: Ice falling into the bin makes a dull thud sound. The sound decreases as the bin fills with ice.
- Solenoid Valves: An occasional clicking sound may be heard as solenoid valves are operated.

### Main Control

The main control board is very robust and is rarely the cause of system issues. It is important to fully diagnose the board for any suspected failures before attempting to remove the board for replacement or service. Follow the guidelines below to fully test and diagnose the main control.



## Power Fault

If the unit does not (or seems to not) power on, follow the flow chart below to help diagnose the issue. Before beginning it is important to first verify the unit is not simply set to sabbath mode

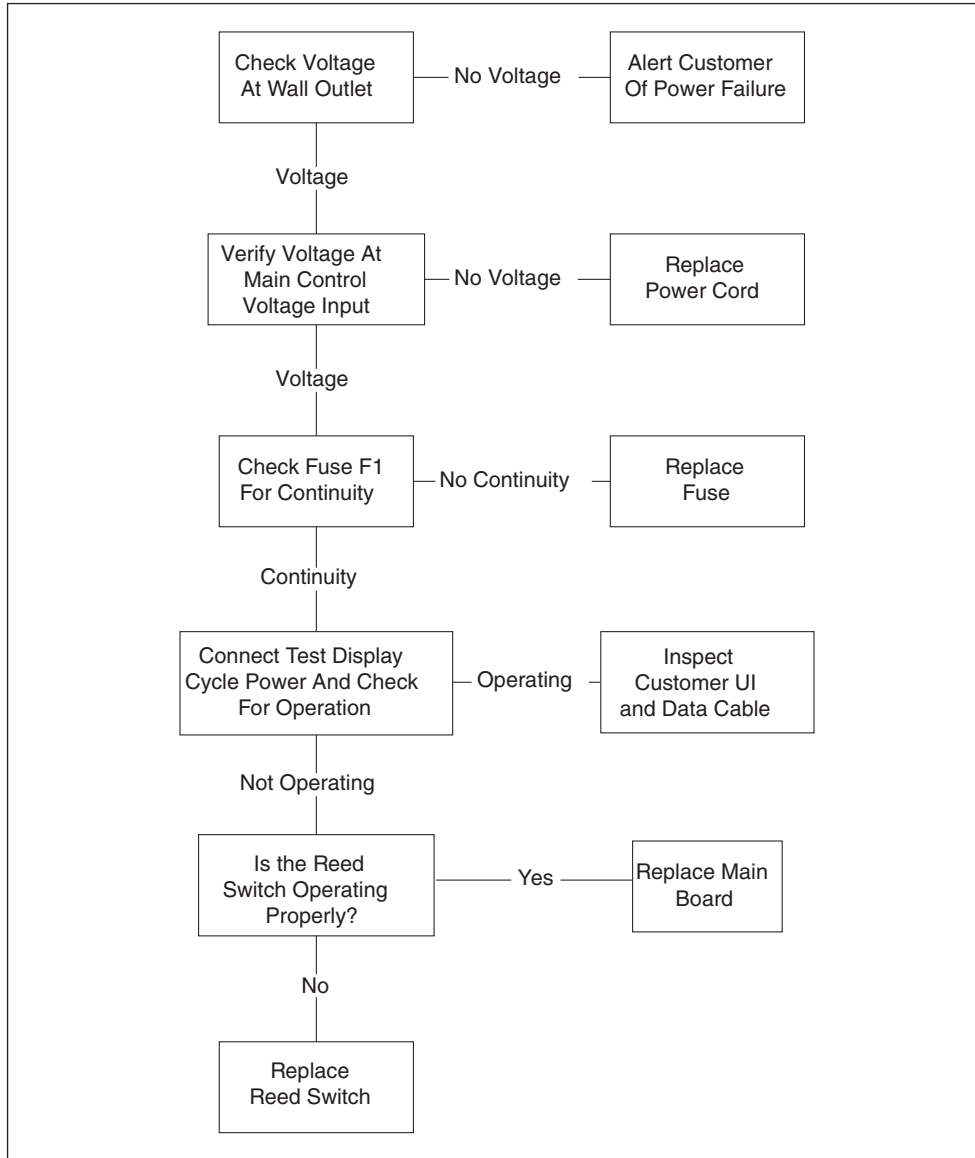

Concern	Potential Causes	Action
No Display or Interior Lights	Unit may be in Sabbath mode	<ul style="list-style-type: none"> <li>• Tap  to turn off Sabbath mode, test the door switch circuit.</li> <li>• Unplug unit, wait 5 seconds, plug back in. If main board does not beep, check for 120V at black and white cables on power cord.</li> </ul>
No Interior Light	Light may be set to OFF Check LED strip for power Defective door switch	Use component testing in service mode and test light circuit, manually test door switch
Condensation on exterior of unit	Is unit exposed to high humidity or high ambient temps?	Moisture will dissipate as ambient temp. and humidity levels fall. Keep exterior of unit well polished to protect surface.
No Ice Production	Is the unit getting water?	Go to component testing and turn on fill valve and verify 120V at the valve.
Low Ice Production	Dirty evaporator, dirty condenser, faulty bin thermistor	Clean the evaporator using U-Line cleaner, clean the condenser coil if needed, check bin thermistor reading in service mode.
Alert light flashing	Check error log	View errors in service mode, review error and take corrective action to resolve
Ice is too dense/not dense enough	Dirty evaporator, water starvation	Clean the evaporator if needed, check water supply, test harvest mode, adjust ice thickness
Standing Water in Ice Bin	Drain hose is restricted, debris in bin drain hole, failed drain pump failed dump valve	Make sure drain hose run is as straight as possible. Remove any kinks or tight bends, pour 1/2 gallon of water into bin to test drain.

## Relay and DC Outputs

One of the primary functions of the main control is to operate the multiple relay and DC outputs during each cycle. Verify proper operation of these relays using the following procedure.

1. Enter "Relay Toggle" through the service menu.

### NOTICE

**Frequently toggling the compressor relay could force the compressor into overload. The compressor will automatically deactivate during an overload and will remain deactivated until the overload switch cools. This could take some time. It is important to allow the compressor at least 5 minutes off time between relay cycles.**

2. Toggle the relay. Its related component should activate / deactivate with the switching of the relay. If it does not, test component.

## Other Suspected Main Control Faults

If other components have been ruled out as being faulty, but the unit continues to have operating issues, it is most likely due to a configuration error. Some configuration errors can be cleared by restoring the unit to its factory default setting. Factory defaults may be restored through the service menu. If that does not work, check that the board is programmed to the correct model in the service menu.



### CAUTION!

*Precautions must be taken while working with live electrical equipment. Be sure to follow proper safety procedures while performing tests on live systems.*

## Plunger Switch

A plunger switch is used to monitor door state. When the door is closed it comes into contact with the plunger which closes a circuit which turns the light and display off. When the door is open the plunger moves outward and opens the circuit. If the door is left open for longer than 5 minutes the switch will trigger an error code and set an audible warning.

Fig. 42

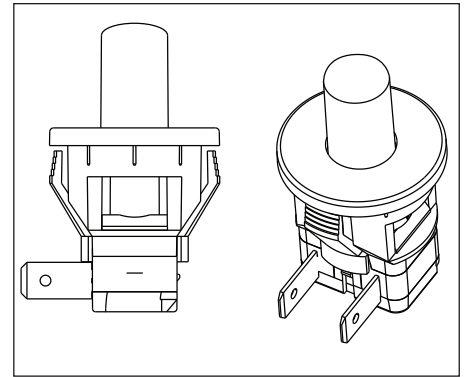

## Error Codes

\*All errors are logged in memory.

\*Only door error is displayed on the display and has an audible signal.

E1: Thermistor 1 open.

E2: Thermistor 2 open.

E3: Thermistor 3 open.

E4: Thermistor 4 open.

E5: Thermistor 1 shorted.

E6: Thermistor 2 shorted.

E7: Thermistor 3 shorted.

E8: Thermistor 4 shorted.

E9: Door 1 open error.

E10: (displayed as 10): Door 2 open

E11: (displayed as 11): Water level (tray or reservoir) high.

E12: (displayed as 12): Water level low.

E13: Auger error

P1: Pump circuit open

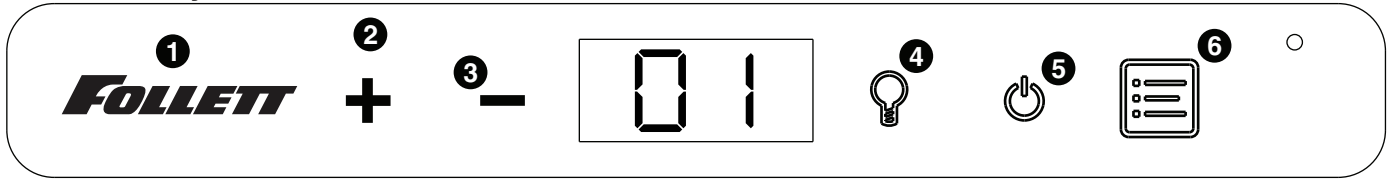

# Control Operation-Service

## UI Button Layout





1. Hidden Button
  - Access Service Menu
  - No LED directly above. All LEDs turn on with button
2. Up Button
  - Increases temperature
  - Navigates through service menu
3. Down Button
  - Decreases temperature
  - Navigates through service menu
4. Light Button
  - Activates light for 3 hours on select models
  - Used to select items in service menu
5. Power Button
  - Turns unit off/on
6. Clean Button
  - Activates Clean Cycle on select models

## Control Function Guide

Function	Command	Display/options
ON/OFF	Press  and release	Unit will immediately turn ON or OFF
Sabbath Mode	See <b>Sabbath Mode</b> section	
Silent Mode (ice production suspended for 3 hours)	Hold  and 	Display will show <b>3H</b>
Clean Mode	See <b>Cleaning</b> section	

### Silent Mode

In some cases it may be requested for the unit to be shut down temporarily - during meetings for example. To do this, hold the  and  for three seconds. The unit will “beep” once and show **3H** on the display. This mode can be canceled by pressing and releasing . The mode will automatically be changed back to ON after three hours.

### Showroom Mode

This mode is designed to show units in a display environment. When in this mode the only functions will be the control and cabinet lights. The compressor, fans, etc. will not operate. To enter/exit this mode hold the light key and the power key for 5 seconds. The display will flash once and beep and the degree symbol will begin to flash. When the degree symbol is flashing the unit will allow the use of the control for demonstrations. The unit can be left in this mode indefinitely.

### Service Mode

This mode has options available for service diagnostics. To enter the mode, hold the hidden key for 10 seconds. The display will show “0.” When in this mode use the up and down arrows to select the desired option. The LIGHT key is the ENTER key and will initiate the function. If changing a setting, you must press the LIGHT key again to retain the changed setting. To exit the service mode scroll to option “0” and press the LIGHT key. After five minutes of not touching any keys the mode will also exit automatically.

# Parts

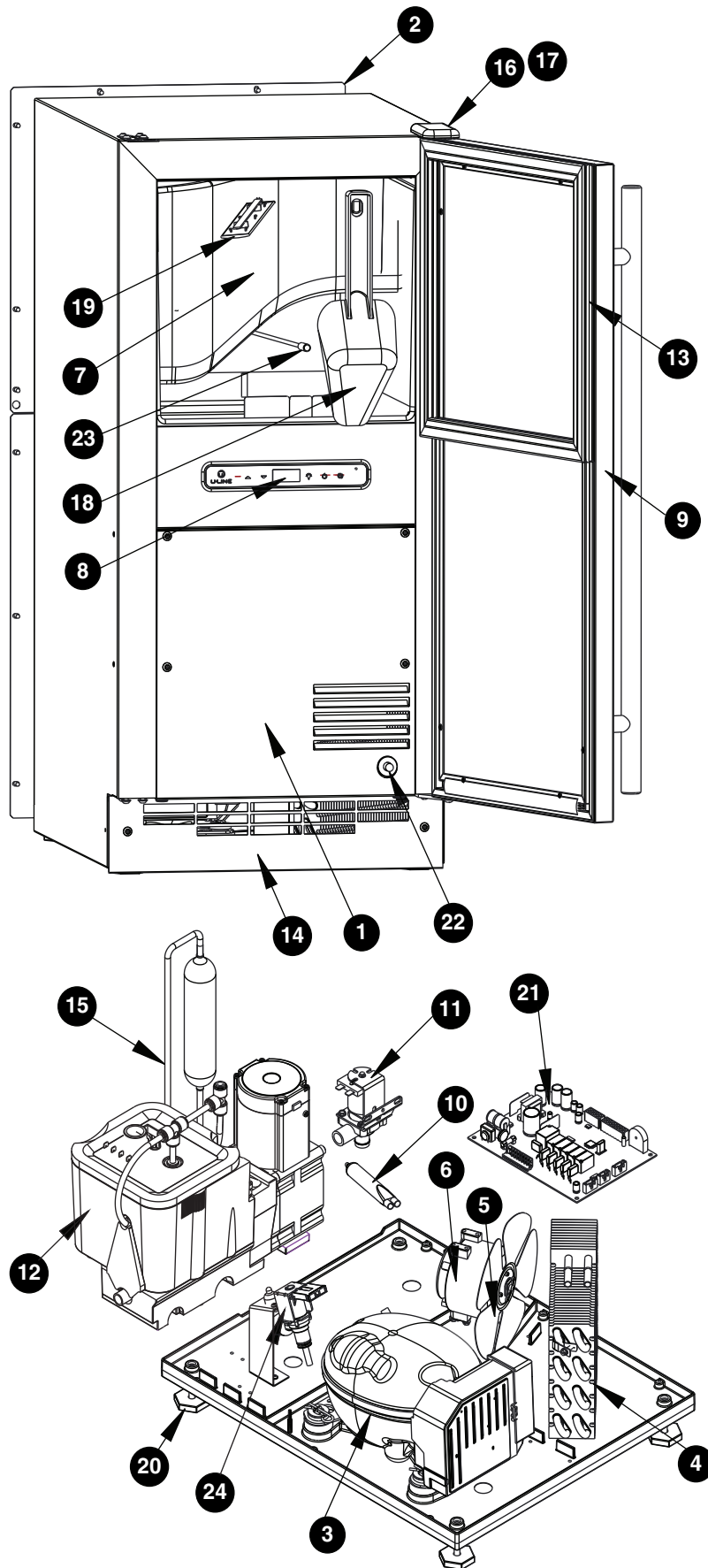

## Exterior

Reference	Description	Part #
1	Panel, access front	01305846
2	Panel, rear	01305853
3	Compressor	01305861
4	Condenser	01305879
5	Condenser, fan blade	01305887
6	Condenser, fan motor	01305895
7	Cover, with hook	01305903
8	Display assembly	01305911
9	Door assembly	01306133
9	Door assembly ADA	01305929
10	Drier	01305937
11	Valve, purge	01305945
12	Module, float, evaporator	01250158
13	Door, gasket	01305952
14	Grill assembly, front-bottom	01305960
15	Heat exchanger assembly	01305978
16	Door, hinge assembly	01305986
16	Door, hinge assembly ADA	01306117
17	Door, hinge cover (2)	01305994
18	Ice scoop	01306000
19	Light, led strip and cover	01306018
20	Legs, levelers (4)	01306026
21	Main board assembly	01306034
Not shown	Safeclean Plus	01147826
22	Switch, door	01306042
Not shown	Power cord, ADA	01306059
23	Thermistor	01306067
24	Valve, reservoir inlet	01306075
Not shown	Wire harness, control board	01306083
Not shown	Sheet metal screw and clips (sold in sets of 20)	01306091
Not shown	Everpure filter	00968107
Not shown	Pump, drain	01306109
Not shown	Power cord	01306125

# Evaporator Assembly

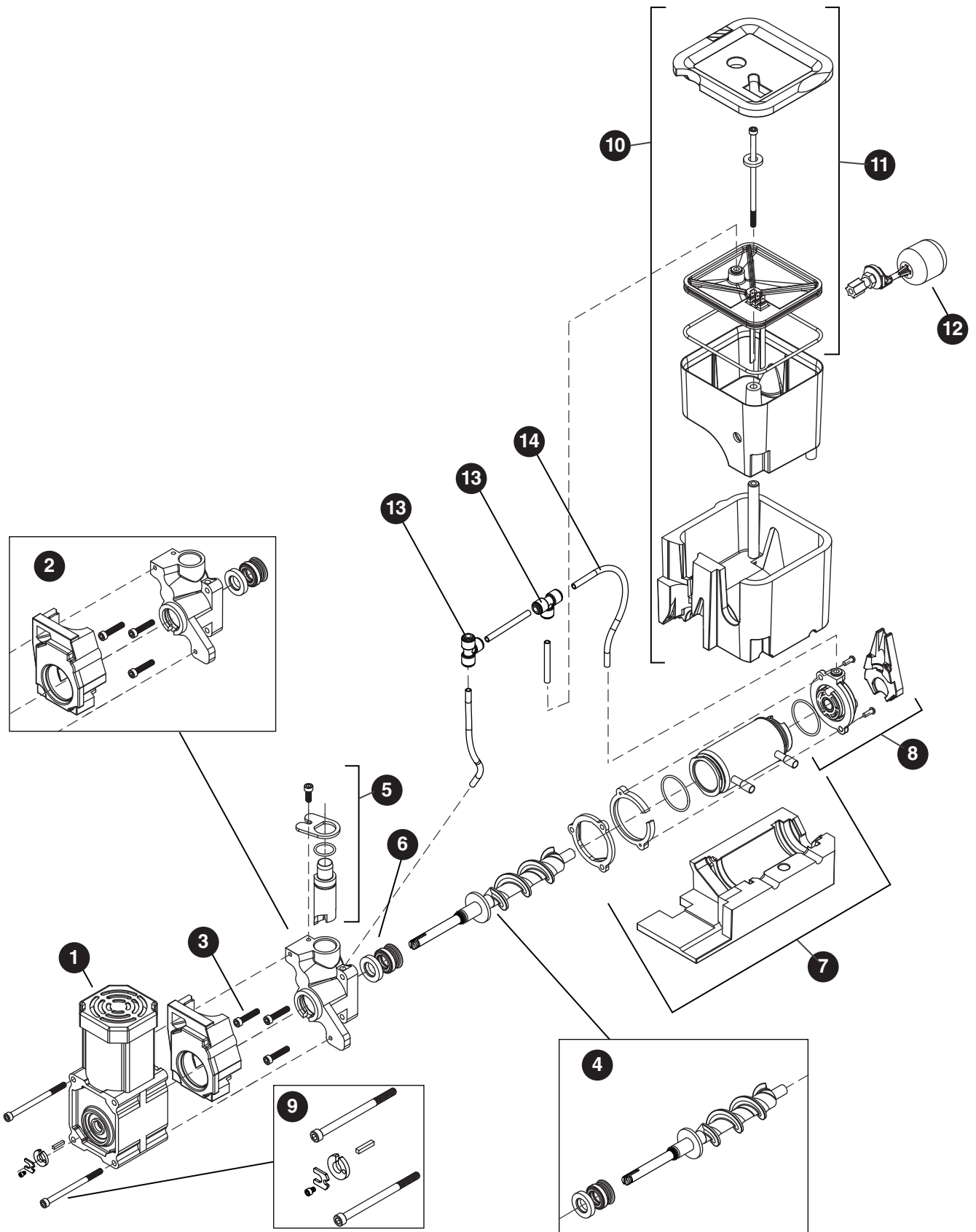



## Evaporator Assembly

Reference #	Description	Part #
1	Gearmotor Assy	00957811
2	Main Housing with Front Seal and Screws	00957829
3	Screws, Main Housing	00957837
4	Auger with front seal	00957845
5	Ice Compression Nozzle Assy	00957852
6	Front Seal and O-Ring	00957860
7	Evaporator Assembly with Insulation	01157353
8	Housing, Bushing with Insulation	00957886
9	Hardware kit, Gearmotor (For serial numbers E01087 and above)	01048628
9	Hardware kit, Gearmotor (For serial numbers below E01087)	00957894
10	Reservoir and Float Complete Assy	00957902
11	Lid, Reservoir with Insulation and O-Ring (does not include bolt)	00957910
12	Float Valve	00957928
13	"T" Fitting - 1/4"	502923
14	Tubing - 1/4" (sold in 12" increments)	502079





## Warranty Registration and Equipment Evaluation

Thank you for purchasing Follett® equipment. Our goal is to deliver high value products and services that earn your complete satisfaction by delivering high-value products and services backed by outstanding customer and technical support.

Please review the installation instructions thoroughly. It is important that the installation be performed to factory specifications so your equipment operates at its maximum efficiency.

Follett LLC will not be liable for any consequential damages, expenses, connecting or disconnecting charges, or any losses resulting from a defect of the machine. For full warranty details, visit our website [www.follettice.com/productwarranties](http://www.follettice.com/productwarranties).

Registering your equipments helps Follett track your equipment's service history should you need to contact us for technical support, and your feedback helps us improve our products and services. Please visit [www.follettice.com/support](http://www.follettice.com/support) to complete the Warranty Registration form.

Should you have any questions, please contact Follett's technical support group at (877) 612-5086 or (610) 252-7301 and we will be happy to assist you.

SafeCLEAN Plus is a trademark of Follett LLC.  
Chewblet and Follett are registered trademarks of Follett LLC, registered in US.



801 Church Lane • Easton, PA 18040, USA  
Toll free (877) 612-5086 • +1 (610) 252-7301  
[www.follettice.com](http://www.follettice.com)



01234673R00  
© Follett LLC 11/19