

# Ice Manager™ diverter valve system

IMDV-2 series

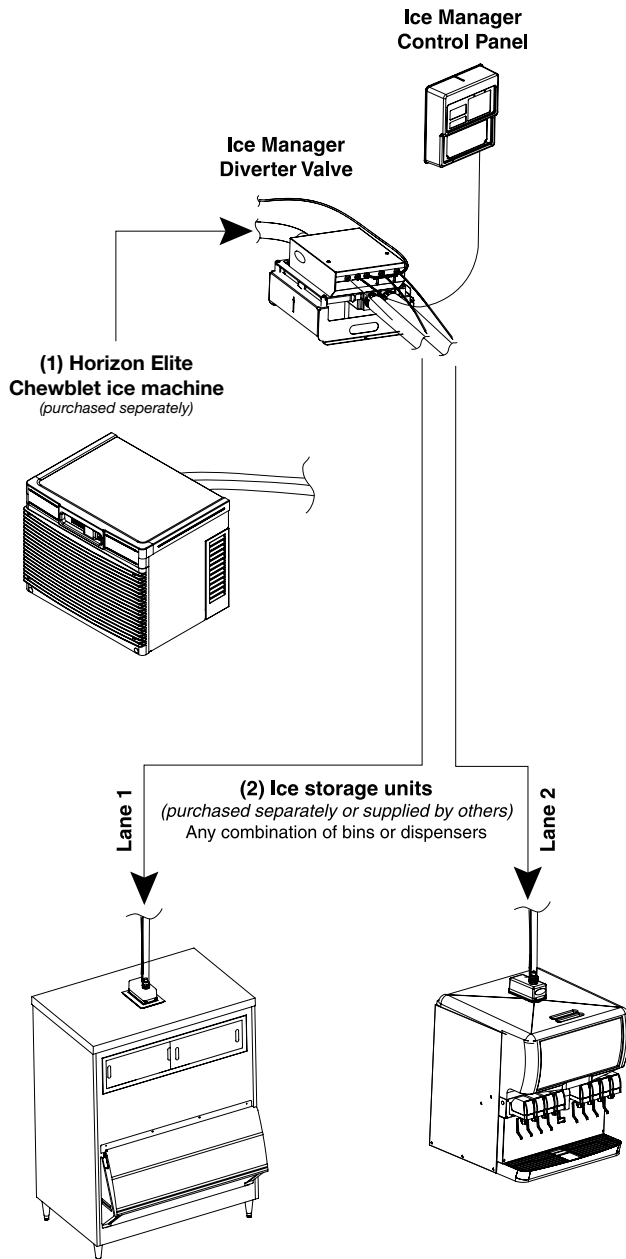

Ice Manager Control Panel



## Features:

The Ice Manager diverter valve system automatically delivers ice from ONE Follett Horizon Elite™ ice machine to TWO separate dispensers or bins. The system includes a control panel, diverter valve, and components to connect two ice storage units chosen.

### RIDE® remote ice delivery equipment

- deliver ice automatically through a tube to where you need it, instead of manually transporting
- reduce handling to provide more sanitary ice and prevent safety issues for employees and customers
- install ice machine and diverter valve up to 75' (22.8 m) away from the bin
- create a more aesthetically appealing dining area with less heat and noise around your customers

### Flexibility with a wide choice of bins and dispensers

- Follett ice storage bins, Ice Transport Systems (ITS), and Ice•Device™ ice storage and dispensing systems
- Follett Vision™ low-profile ice and beverage dispensers and Symphony Plus™ 110CM ice and water dispensers
- countertop ice and beverage dispensers manufactured by others (see approved list on page 2)
- other ice storage containers (contact factory)

### Efficient use of equipment

- fill two bins or dispensers with only one ice machine
- reduce the number of ice machines in your operation, or eliminate manual filling
- keep one machine running more efficiently instead of two machines that may idle frequently
- service and maintain only one machine instead of two

### Factory-arranged installation and start-up

- turn-key system installation with factory-trained installers
- full operational demonstration to end-user

### Warranty

- 3 years parts and labor on all components

Job

Item

# Configuring the Ice Manager diverter valve system

## 1. Select Horizon Elite ice machine model

Using the model configuration table below, determine the Horizon Elite ice machine that will best suit your needs. For more specifications on Horizon Elite ice machine models, see form# 7030, 7035, 8180 and 3311. Existing Horizon series ice machines may be retrofitted to integrate with the Ice Manager diverter valve system. Based on model# and serial#, determine the retrofit kit to order using the table below.

Horizon Elite ice machine model: \_\_\_\_\_

serial# (if existing Horizon ice machine): \_\_\_\_\_

### Horizon Elite 1010, 1410, 1810 and 2110 Series Ice Machine Model Number Configurations for use with Ice Manager Diverter Valve System

Icemaker	Voltage	Series	Condenser	Application	Configuration
HC Horizon Chewblet	C 208-230/60/1 (icemaking head) <i>Self-contained only.</i>	1010	A Air-cooled, self-contained	M Ice Manager	S RIDE <i>(remote ice delivery equipment)</i>
	D 115/60/1 (icemaking head) <i>Self-contained and remote. If remote unit, high side is 208-230/60/1.</i>	1410	W Water-cooled, self-contained		
	F 115/60/1 (icemaking head) <i>Remote only. High side is 208-230/60/3.</i>	1810	R Air-cooled, remote condensing unit		
		2110	N Air-cooled, no condensing unit for connection to parallel rack system		

### Horizon Series Retrofit Kits<sup>1</sup>

Horizon Model #	Item #
1000/1400/1650 after C43650	00191965
1000/1400A/W prior to C43650	00185181
1000/1400R/N prior to C43650	00185272
1010/1410/2110/1810	01116177

<sup>1</sup> Extra transport tubing may be required to connect ice machine to diverter valve

## 2. Select two dispensers or bins to be filled

Choose two approved units for ice storage. If exact model is not known, note type of unit. **Lane 1 is the primary lane and should be assigned to bin or dispenser with highest demand.**

Lane 1: \_\_\_\_\_

Lane 2: \_\_\_\_\_

If desired unit is not listed below, contact factory.

Follett Ice Transport and Storage		
New Follett ice storage bin or transport system model. See form# 8590 for models. When ordering bin, specify bin top to be cut for Ice Manager diverter valve system. If ice machine will be top mounted on bin, see Step 3.		
Existing Follett ice storage bin or transport system model. Requires replacement top cut for Ice Manager diverter valve system. See form# 4025 for item numbers. If ice machine will be top mounted on bin, see Step 3.		
Follett Symphony Plus Ice and Water Dispenser 110CM		
Follett Vision Ice and Beverage Dispensers		
New Follett Vision 155 and 300 ice and beverage dispenser model. VU155N models are available via Special Quote Request (SQR). See form# 4025 for models. Order Vision with VUIMDVKIT to be configured for Ice Manager diverter valve system.		
Existing Vision 155 serial# must be greater than B50001. Existing Vision 300 serial# must be greater than B50005.		
Ice and Beverage Dispensers <sup>1</sup>		
Coca-Cola Freestyle 9000 <sup>2</sup>	Lancer 4500-22N	Servend MD150
Coca-Cola Freestyle 7000 <sup>2,3</sup>	Lancer 4500-30N	Servend MD175
Coca-Cola Freestyle 9100 <sup>2,4</sup>	Lancer FS-16N	Servend MD200
Cornelius ED/DF150 Series	Lancer FS-22N	Servend MD250
Cornelius ED/DF175 Series	Lancer FS-30N	Servend MDH302
Cornelius ED/DF200 Series	Lancer FS-44N	Servend MDH302
Cornelius ED/DF250 Series	Lancer Sensation 30"/44"	Servend MDH402
Cornelius ED/DF300 Series	Lancer Touchpoint	Servend SV175
Cornelius IDC215	Lancer Bevariety	Servend SV200
Cornelius IDC255/Pro/Fast Gate	Pepsi Spire 3.0/5.0/4.1 <sup>5</sup>	Servend SV250
Cornelius Flavor Fusion/Overload	Servend FRP-250	

<sup>1</sup> Consult with dispenser provider to be sure the dispenser is ready to dispense nugget ice.

<sup>2</sup> Consult with Coca-Cola and Follett to qualify application prior to ordering.

<sup>3</sup> Requires DVF30 top kit ordered separately from Follett and top adapter kit 46412 and ice kit 46430, which must be ordered from Coca-Cola.

<sup>4</sup> Requires DVF26 top kit ordered separately from Follett.

<sup>5</sup> Approved only for Pepsi Spire 3.0, 5.0 and 4.1 designed for top mount ice machines. Requires DVP22 top kit for 3.0 and DVP30 top kit for 5.0 and 4.1, ordered separately from Follett. For manual fill versions of Pepsi Spire 3.0, 5.0 and 4.1, contact factory.

## 3. Choose Horizon Elite series ice machine mounting option

Mounting option: \_\_\_\_\_

Wall Mount Bracket	Item #
HCD1010/1410 and HCF1010/1410/2110	00997098
HCC1010 and HCC1410	01085455
Machine Stand	Item #
HCC1010 and HCC1410	01085463
HCD1010/1410/1810/2110 and HCF1010/1410/1810/2110	00997080
Follett Bin - Top Mount <sup>1</sup>	
New bin, see form# 8590 for models. When ordering bin, specify bin top to be cut for Ice Manager diverter valve system and ice machine <sup>1</sup> .	
Existing bin, see form# 4025 for bin top listing. Requires replacement top cut for Ice Manager diverter valve system and ice machine when ordering <sup>1</sup> .	
Other	
Specify what the Horizon series ice machine will be mounted on.	

<sup>1</sup> See drawings on page 3 for min. bin width and required clearances.

# Configuring the Ice Manager diverter valve system (Continued)

## 4. Evaluate site for location of equipment

### Lane 1 and Lane 2 dispensers or bins

- Refer to dispenser or bin specifications for required clearances
- See drawings below for required clearances for Ice Manager diverter valve system

### Follett Horizon Elite ice machine

- 10' (3 m) maximum distance from Horizon Elite ice machine to diverter valve
- See spec sheets 7030, 7035, 8180 and 3311 for utility requirements and dimensions

### Diverter valve

- 8' (2.4 m) maximum distance from diverter valve module to electric outlet
- 75' (22.8 m) maximum distance from diverter valve to Lane 1 and Lane 2 dispensers or bins
- Drain required, 15' (4.6 m) drain tube provided

### Control panel

- 30' (9.2 m) max. distance from control panel to diverter valve

## 5. Determine length of ice transport tubes

Lane 1: (approx. length): \_\_\_\_\_

Lane 2: (approx. length): \_\_\_\_\_

Use the following guidelines to determine length of the ice transport tube run from the diverter valve to each bin or dispenser.

- Length of ice transport tube from diverter valve module to each dispenser or bin can be specified in 5' (1.5 m) increments from 10' - 75' (3.0 m - 22.8 m)<sup>1</sup>
- Maximum vertical rise of ice transport tube – 10' (3 m)
- Horizontal run should be pitched so that melt water drains back to diverter valve module. Run must have 1/4" per foot pitch.
- No dips or traps in the tube run

<sup>1</sup> Lengths to include any bends and turns needed to connect components.

## 6. Site plan drawings

Installation may be performed by an authorized installer contracted by Follett. Contact factory for details.

# Required clearances for Ice Manager diverter valve system

### Diverter valve

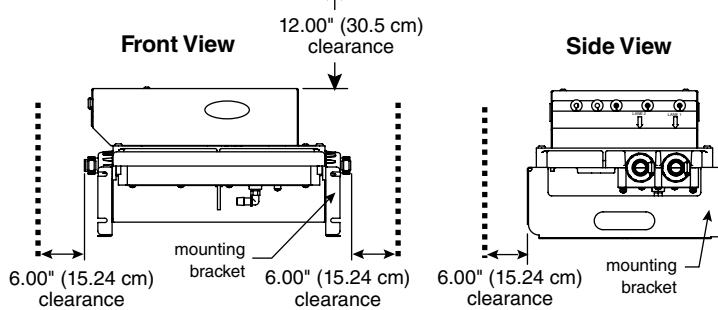

### Sensor distribution unit

(bins and ice and beverage dispensers only)

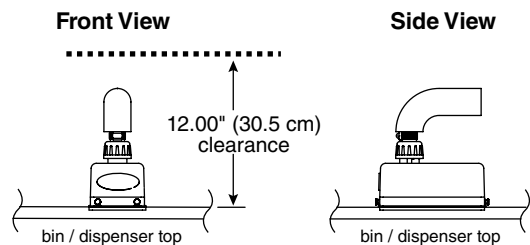

### Insulated transport tube

(RIDE applications)

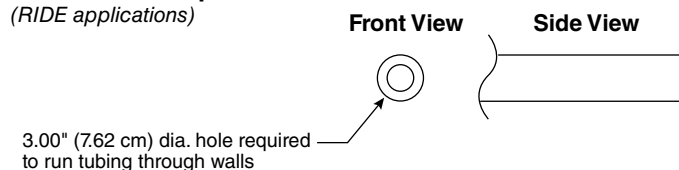

### Top mount on a bin (minimum bin width)

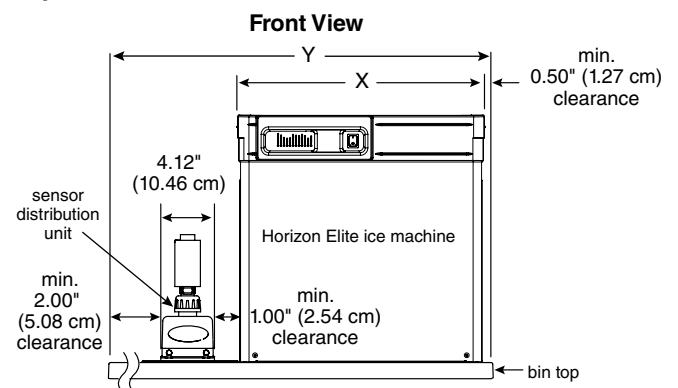

**Note:** For 30.00" (76.2 cm) Follett bin, sensor distribution unit may be placed behind ice machine.

## Specification

### Control panel

<b>W1</b> Width of control panel	12.00" (30.5 cm)
<b>D1</b> Depth of control panel	3.75" (9.52)
<b>H1</b> Height of control panel	12.50" (31.8 cm)
Connections	30' (9.2 m) cable to diverter valve

### Diverter valve with mounting bracket

<b>W2</b> Width of diverter valve	13.62" (34.6 cm)
<b>D2</b> Depth of diverter valve	17.50" (44.4 cm)
<b>H2</b> Height of diverter valve	10.38" (26.4 cm)
Connections	8' (2.4 m) cord and plug, 15' (4.6 m) drain tubing
<b>C1</b> Drain	3/8" NPT barbed drain fitting
Lane 1	insulated ice transport tube and sensor cable to diverter valve <sup>†</sup> , and connection kit for ice storage unit used <sup>†</sup>
Lane 2	insulated ice transport tube and sensor cable to diverter valve <sup>†</sup> , and connection kit for ice storage unit used <sup>†</sup>
Electrical	1.5 amps, 8' (2.4 m) cord, NEMA 5-15 plug

### Sensor distribution unit

<b>W3</b> Width of distribution sensor	4.12" (10.46 cm)
<b>D3</b> Depth of distribution sensor	7.75" (19.68 cm)
<b>H3</b> Height of distribution sensor	3.50" (8.89 cm)

### General information

Approximate ship weight of Ice Manager with 50' (15.2 m) of ice transport tube	120 lb (55 kg)
Operating temperature	40 - 120 F (4 - 49 C), relative humidity not to exceed 55%

‡ Lengths to be specified by customer.

† Follett Vision ships with connection kit factory-installed (item# VUIMDVKIT).

NOTE: For indoor use only

SHORT FORM SPECIFICATION: Ice Manager diverter valve system to be model IMDV-2. System to direct ice delivery to two bins or dispensers automatically, utilizing sonic sensors to control level of ice.

Ice machine to be Follett Horizon Elite model \_\_\_\_\_.

Lane 1 to fill \_\_\_\_\_.

Lane 2 to fill \_\_\_\_\_.

(ice and beverage dispenser, bin or Vision)

Horizon Elite ice machine to be mounted on \_\_\_\_\_

(bin, wall mount bracket or machine stand)

System to include \_\_\_\_\_ feet of insulated ice transport tube for Lane 1, and \_\_\_\_\_ feet of insulated ice transport tube for Lane 2<sup>1</sup>.

(75' (22.8 m) max. length for each lane)

Horizon Elite ice machine and Ice Manager NSF, UL, and cUL listed.

System to be installed by Follett.

<sup>1</sup> Lengths to be confirmed on-site prior to shipment. Lengths to include any bends and turns needed to connect components.

## Dimensional drawing

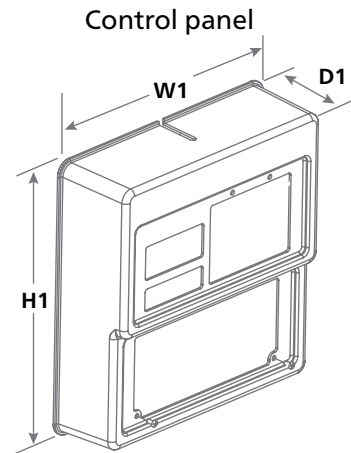

Diverter valve with mounting bracket

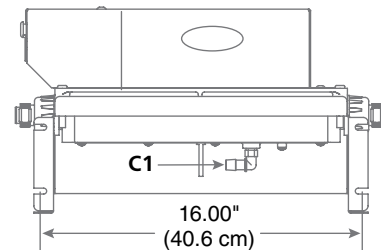
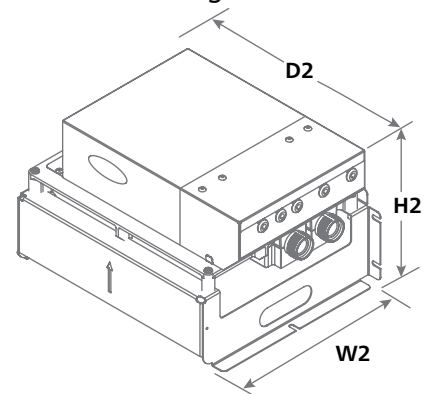

Sensor distribution unit

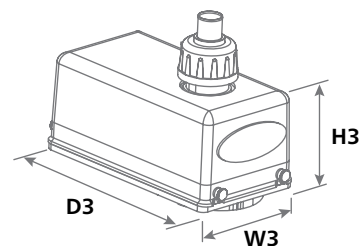

HORIZON, HORIZON ELITE, ICE•DEVICE, ICE MANAGER, SYMPHONY PLUS and VISION are trademarks of Follett LLC.  
CHEWBLET, FOLLETT and RIDE are registered trademarks of Follett LLC, registered in the US.  
Follett reserves the right to change specifications at any time without obligation. Certifications may vary depending on country of origin.

## Ice Manager diverter valve system