



Horizon Elite™ Chewblet® ice machines  
superior technology delivering value and reliability

Horizon Elite™ is a revolutionary advancement in ice machine design that protects against scale-prone water conditions to substantially reduce life cycle cost.

## How is your water?

All water contains dissolved minerals, also called Total Dissolved Solids (TDS). Water containing high levels of TDS is commonly referred to as "hard" and is prone to create scale in foodservice equipment. Water conditions around the world vary widely. The USGS reports 85% of the US has hard water.

## What's the impact of poor water quality?

- All ice machines are affected by high dissolved mineral content that results in scale buildup causing
  - Increased need for costly cleaning and descaling of the evaporator
  - Decreased production as mineral deposits reduce the efficiency of ice making
  - Premature failure of components
  - Greater potential for drain clogs
  - Overall reduction in equipment life
- High levels of TDS in nugget machines
  - Result in softer ice, which increases the potential of jamming in beverage dispensers
  - Increase the melt rate of ice
- Many cube ice machines attempt to mitigate scale by increasing purge rate, which consumes more than twice as much water and increases electrical costs

Scale forms on any surface in contact with water.

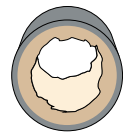

High TDS

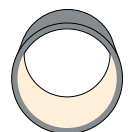

Low TDS

## What is the cost of scale in hard water?

Machines that flush excess water drive up water costs and negatively impact the environment.

In scale-prone, high TDS water, machines need to be descaled far more frequently, sometimes as often as every month or two. Each descaling can cost \$200.

An alternative to frequent descaling is to treat the incoming water to remove minerals. Reverse osmosis, a common technique to deal with hard water, can be expensive (up to \$1000 up front and \$200 in annual consumables) and can triple water usage.

Finally, neglecting descaling can significantly shorten equipment life, leading to thousands of dollars of premature re-investment in parts and equipment.

## How does Horizon Elite remove TDS?

The incoming water introduced at the front end of the evaporator forces the high TDS water that has been created in the ice making process to move to the reservoir at the back of the machine. The mineral-laden water is then expelled in small volume flushes. The result is high quality ice with a fraction of the water that cube ice machines use.

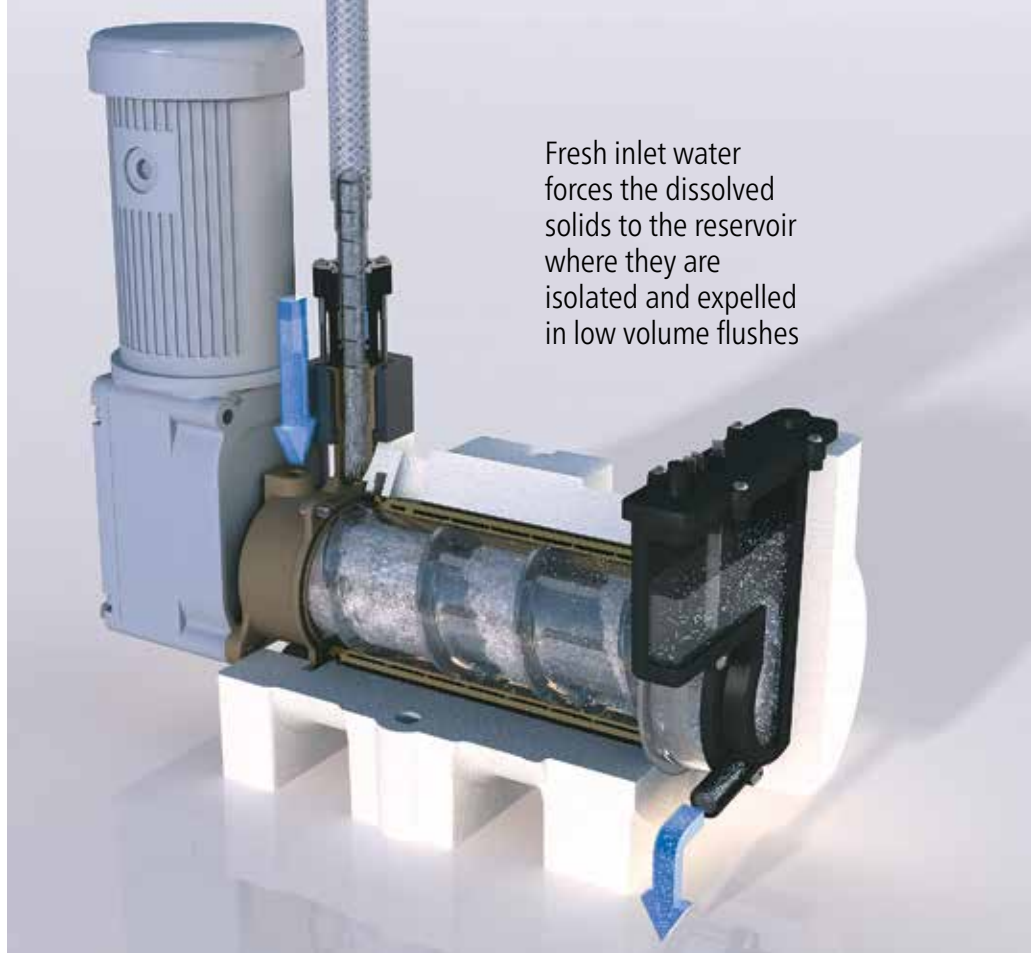

Fresh inlet water forces the dissolved solids to the reservoir where they are isolated and expelled in low volume flushes

## Horizon Elite removes 85% of TDS (total dissolved solids)

- Substantially less frequent descaling
- Reduced loads on parts for increased reliability
- Longer equipment life
- Reduced need for expensive TDS removal systems
- Cube-like ice quality for improved dispensability to eliminate jammed dispensers



The picture above shows a Horizon Elite auger that remains scale-free, even after a year in high 310 ppm TDS water conditions (>180 is considered very hard per USGS)

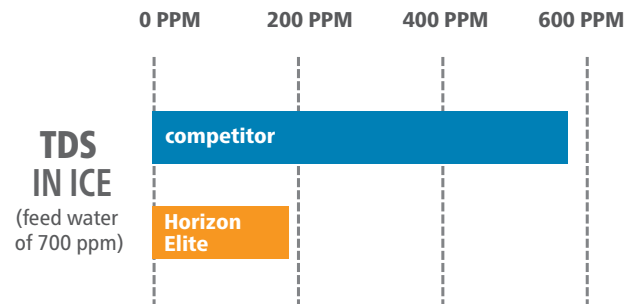

Ice containing high TDS dispenses poorly and can increase scale buildup in dispenser and bin storage areas

## Efficient design

- Reduces water usage by 35% over typical cube ice machines at standard setting
- Reduces water usage by more than 50% in high TDS applications
- Uses high-efficient aluminum bronze in the evaporator (twice as conductive as stainless steel)
- Harvests ice without reversing the refrigeration cycle or adding heat (unlike cube ice machines)



Water used per 100 lbs (45 kg) of ice

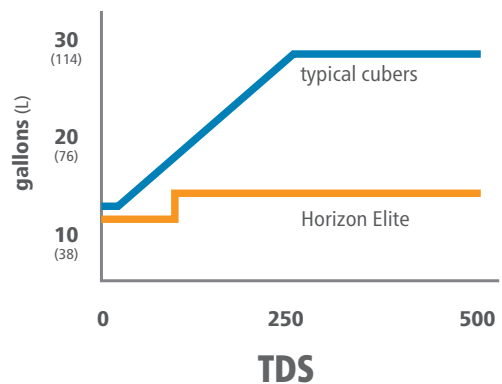

Cube ice machines mitigate scale in higher TDS applications by significantly increasing water usage

## Upgraded diagnostic capability

- Allows on-site identification for remote diagnosis of problem before technician arrives, promoting first-time fix
- Aids service technicians in fast troubleshooting to minimize downtime
- Gives instant feedback to identify service issues before they become a problem





Streamlined cleaning and sanitizing process is easy for in-store personnel to perform in less than 30 minutes.

1 – Press the clean button. Wait for LO WATER light to come on.

2 – Fill cleaning cup with SafeCLEAN Plus™ cleaning solution until HI WATER light comes on. The ice machine does the rest!

The auger rotates in the evaporator for 5 minutes to circulate the cleaning solution. After automatically draining the solution, the evaporator refills with fresh water. The water is circulated for 2 minutes and then drained. The “rinse” cycle is repeated two more times.



3 – Disconnect the ice transport tube at the tube coupling and insert a dry SaniSponge™ followed by a sponge soaked in SafeCLEAN Plus cleaning solution. Reconnect the coupling and turn on the machine. As ice is harvested, it will push the sponges through the ice transport tube to sanitize it. Catch and discard the sponges and a small amount of ice.



## Gearmotor

Gearmotor doesn't require the annual inspection that other nugget ice machine manufacturers recommend

## Shuttle

Industry-exclusive level control shuts off ice machine without a thermostat, reducing the risk of failure

## Reservoir

Reservoir isolates high TDS water and frequently expels it in low volume dumps

## Compression nozzle

Unique nozzle design removes excess water for high quality, reliable dispensing ice

## Evaporator

Inlet feed water drives dissolved minerals (TDS) toward reservoir and drain

## Auger

The auger design contains harvesting loads within the evaporator to reduce loads on the gearmotor and assure long life

## Drain

Direct pipe to drain connection reduces evaporation and drain clogs from scale buildup

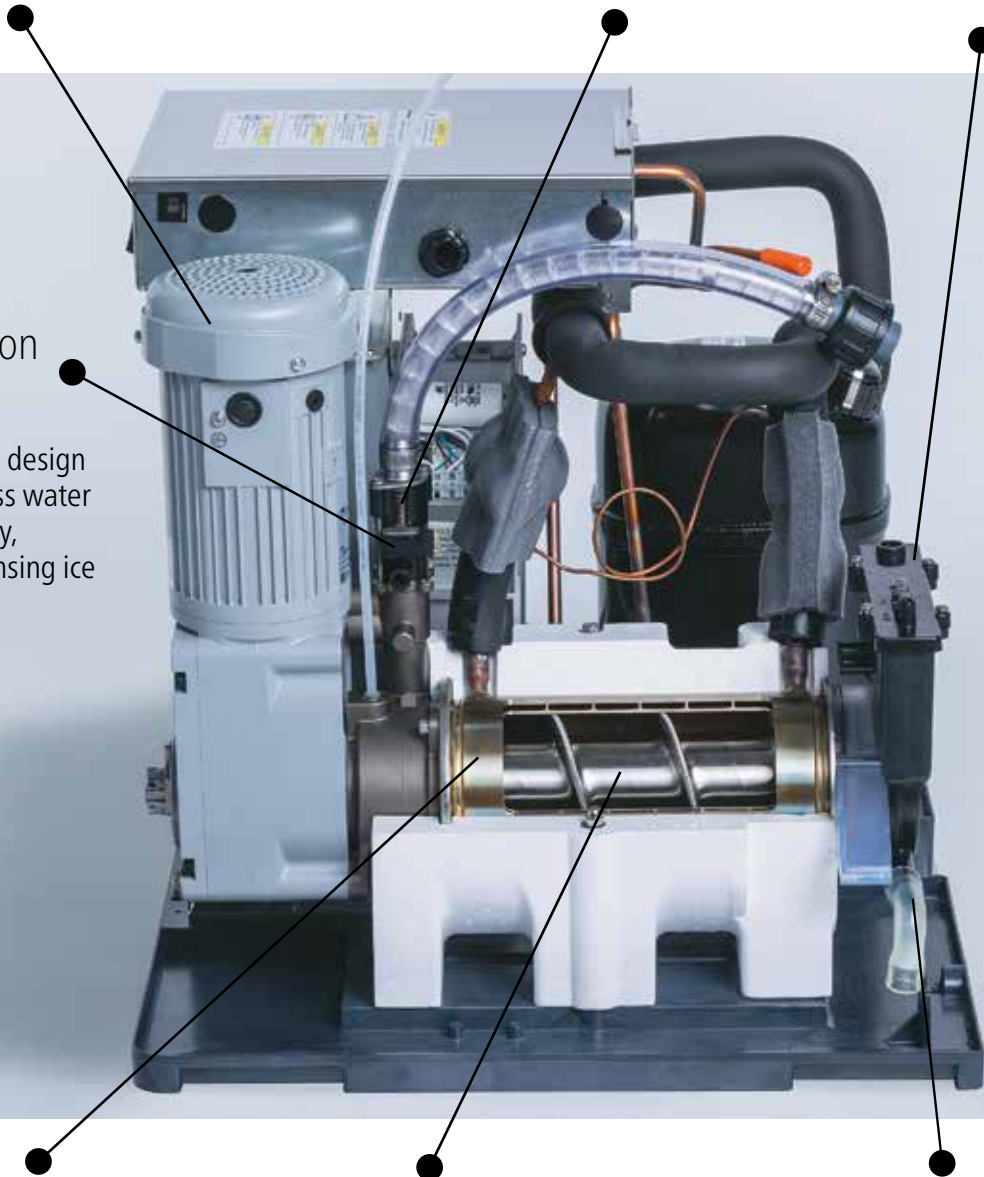

HORIZON ELITE, SAFECLEAN PLUS and SANISPONGE are trademarks of Follett LLC. FOLLETT and CHEWBLET are registered trademarks of Follett LLC, registered in the U.S. Follett reserves the right to change specifications at any time without obligation.

**FOLLETT**<sup>®</sup>

801 Church Lane | Easton, PA 18040, USA  
+1 610.252.7301 | 800.523.9361 | follettice.com



6995-202004 | © Follett LLC