

U150 Series Ice Dispensers

Order parts online
www.follettice.com

Operation, Service and Parts Manual

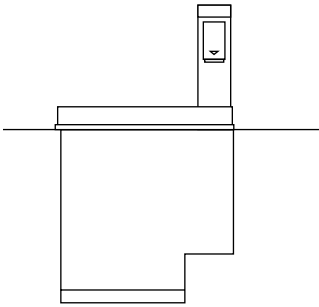

U150N

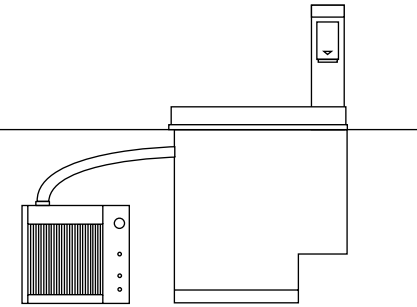

**U150NR4A/W
U150NR5A/W**

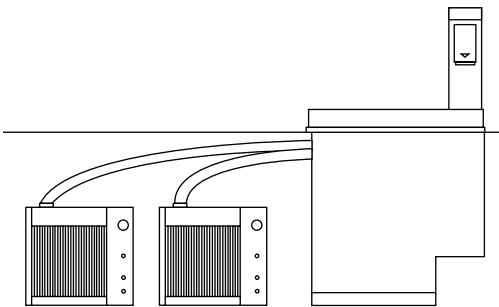

**U150NR8A/W
U150NR10A/W**

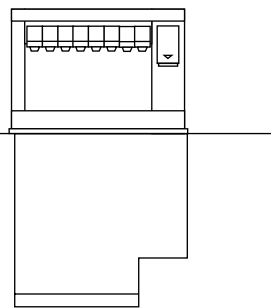

**U150
U150B**

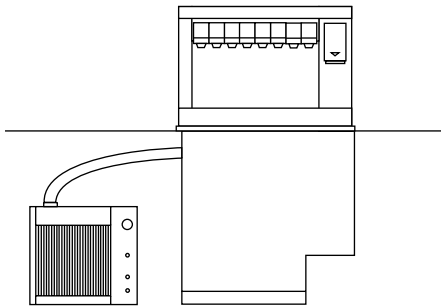

**U150R4A/W
U150R5A/W
U150BR4A/W
U150BR5A/W**

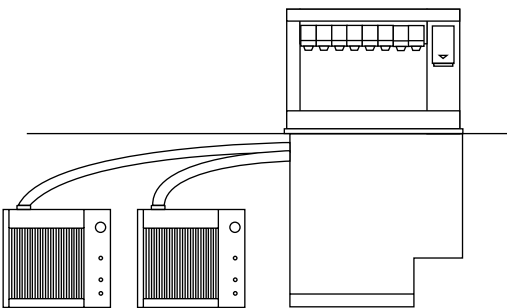

**U150R8A/W
U150R10A/W
U150BR8A/W
U150B10A/W**

Welcome to Follett

Follett ice dispensers enjoy a well-deserved reputation for excellent performance, long-term reliability and outstanding after-the-sale support. To ensure that this dispenser delivers that same degree of service, we ask that you take a moment to review this manual before using the dispenser. Should you have any questions or require technical help at any point, please call our technical service group toll free at (800)523-9361 or (610)252-7301.

Before you begin

Check your paperwork to determine which model you have. Following is an explanation of the different model numbers in the U150 series.

U150BR5A

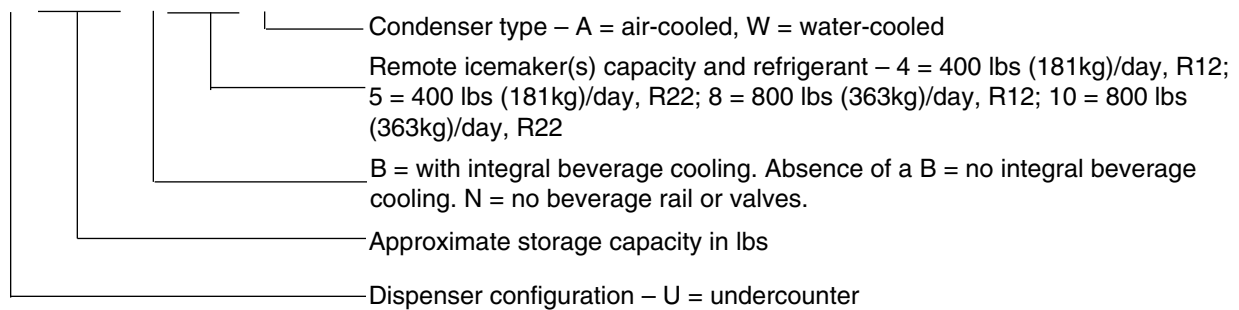

Important cautions

- Storage area of dispenser contains mechanical, moving parts. Keep hands and arms clear of this area at all times. If access to this area is required, power to unit must be disconnected first.
- **Follett manual load units can accommodate most cube/cubelet ices up to 1" square, or Follett compressed nugget ice. Crushed, flake, bagged, nugget or congealed ice cannot be used. Use of these ices can jam dispenser and void warranty. Separate any "waffle-like" sections of cubes before adding to dispenser. If you have any questions concerning your ice type, please call Follett's customer service group toll free at (800) 523-9361 or (888) 2-FOLLETT or (610) 252-7301.**
- Follett recommends use of an activated carbon filter for units equipped with icemakers
- Ice is slippery. Maintain counters and floors around dispenser in a clean and ice-free condition.
- Ice is food. Follow recommended cleaning instructions to maintain cleanliness of delivered ice.

Electrical specifications

Standard electrical - 115V, 60Hz, 1 phase

Separate circuit and disconnects required for each icemaker and dispenser. Max. fuse size 20 amps per circuit

Manual load models

U150N – dispenser 2.4 amps

U150 – dispenser 2.4 amps

U150B – dispenser 4.4 amps

Models with R4A/W Icemaker

U150R4A/W, U150NR4A/W – 13.4 amps

U150BR4A/W – 15.4 amps

U150R8A/W, U150NR8A/W – 24.4 amps

U150BR8A/W – 26.4 amps

Models with R5A/W Icemaker

U150R5A/W, U150NR5A/W – Icemaker 11.0 amps, dispenser 2.4 amps

U150BR5A/W – Icemaker 11.0 amps, dispenser 4.4 amps

U150R10A/W, U150NR10A/W – (2) icemakers 11.0 amps each, dispenser 2.4 amps

U150B10A/W – (2) icemakers 11.0 amps each, dispenser 4.4 amps

- Equipment ground required.
- Separate circuit and disconnects required for each icemaker and dispenser. Disconnects suggested within 10 ft (3m) of dispenser and icemaker(s).

Alternate electrical - 230V, 50Hz, 1 phase

Separate circuit and disconnects required for each icemaker and dispenser. Max. fuse size 15 amps per circuit

Manual load models

U150N – dispenser 1.7 amps

U150 – dispenser 1.7 amps

U150B – dispenser 2.2 amps

Models with R4A/W Icemaker

U150R4A/W, U150NR4A/W – 7.7 amps

U150BR4A/W – 8.2 amps

U150R8A/W, U150NR8A/W – 13.7 amps

U150BR8A/W – 14.2 amps

Models with R5A/W Icemaker

U150R5A/W, U150NR5A/W – Icemaker 6.0 amps, dispenser 1.7 amps

U150BR5A/W – Icemaker 6.0 amps, dispenser 2.2 amps

U150R10A/W, U150NR10A/W – (2) icemakers 6.0 amps each, dispenser 1.7 amps

U150B10A/W – (2) icemakers 6.0 amps each, dispenser 2.2 amps

Plumbing

Dispenser – all models

- 3/4" female PVC slip joint dispenser drain
- 3/4" male slip joint to 3/4" MPT PVC adapter provided

Note: Drains to be hard piped and insulated, with 1/4" per foot (6mm per 30.4cm) min. slope.

Icemaker – automatic load models only

- 1/4" FPT water in
- 1/2" MPT drain
- 3/8" FPT condenser inlet (water-cooled condenser only)
- 1/2" FPT condenser drain (water-cooled condenser only)

Note: Water disconnect within 10 feet (3m) of icemaker(s) is suggested for automatic load units.

Beverage connections - Models with beverage valves only

- 1/4" syrup and 3/8" carbonated water pigtails.

How the dispenser works

Follett's U150 series ice dispensers are available in manual load configurations (using ice from another source) or automatic load configurations, fed from one or two Follett 400 lb (181kg)/day remote icemakers.

In all models, ice is stored below the counter in the dispenser storage area. When the dispense lever or button is pushed, the dispense motor is activated. This causes the wheel assembly in the storage area to turn, moving ice to the vertical auger assembly, which carries ice up to the dispense chute where it drops by gravity into the container.

In automatic load models, ice is manufactured in either one or two Follett remote icemakers. These icemakers may be located up to 20 feet (3m) away from the dispenser. As water freezes to the inside walls of the icemaker evaporator, a rotating stainless steel auger removes ice and carries it to the top of the evaporator assembly where it is compressed and extruded through an outlet port. The extruded ice is then pushed through the tube to the storage compartment of the dispenser. A level fill circuit maximizes fill in the storage area by rotating the wheel at intervals until the bin is completely filled. When the bin is filled, a bin stat shuts the icemaker off to avoid overfilling of the bin. U150 dispensers equipped with R4A/W (R12 refrigerant) icemakers have a safety thermostat that prevents the icemaker from restarting for 15 to 30 minutes after the bin stat has shut the icemaker down. In U150 dispensers with R5A/W (R22 refrigerant) icemakers, the icemaker will restart after 15 to 20 minutes if the bin is calling for ice.

From Serial Number 40600 and up, models with integral ice-waterbath beverage cooling are equipped with a waterbath timer circuit that activates the waterbath pump 1 minute on and 10 minutes off to ensure optimal beverage cooling.

To start-up and operate dispenser

1. Follow cleaning instructions in U150 Series Installation Manual before operating dispenser.
2. Follow start-up instructions in U150 Series Installation Manual for beverage line hook-up instructions, initial loading of ice-waterbath beverage cooling system, manual loading restrictions and/or automatic load start-up requirements.
3. Turn power and feed switches located inside beverage rail or ice tower to ON position.
4. For manual load models, remove front drain pan or rear lid and fill storage area with compatible ice.
5. For automatic fill models, turn icemaker (bin signal) switch(es) located inside beverage rail or ice tower to ON position and begin to make ice.
6. When dispenser has at least 6" (153mm) of ice in storage area, press PUSH FOR ICE lever or button to insure that dispenser is operating properly.

Periodic cleaning of dispenser

Caution: Do NOT run plastic parts (drain pan, dispense chute cover, dispense wheel) through a dishwasher.

Solution A: Prepare a cleaning solution (200 ppm of available chlorine content) of Ecolab Mikro-chlor Cleaner or equal chlorinated detergent. Solution temperature must be 75° to 125°F (24° to 52°C).

Solution B: Prepare a sanitizing solution (50 ppm of available chlorine content) of Ecolab Mikro-chlor Cleaner or equal chlorinated detergent. Solution temperature must be 75° to 125°F (24° to 52°C).

Recommended daily cleaning of drain pan

1. Remove all debris from drain pan.
2. Pour 1 gallon (4L) hot water into drain pan to keep drain lines clear.

Recommended weekly cleaning

1. Remove drain pan and grille and wash with Solution A above. Rinse thoroughly.
2. On units with beverage valves, remove nozzles and diffusers from valves, soak for at least 10 minutes in cleaning Solution A, rinse, sanitize with Solution B and reinstall.
3. Pour a solution of one cup (8oz/237ml) household bleach mixed with one gallon (3.8L) hot water into drain pan to help prevent algae growth in drain lines.

Recommended quarterly cleaning (every 3 months)

Caution: Remove dispense switch from dispense chute before cleaning chute.

1. Turn power switch to OFF position.
2. Remove ice from storage area.
3. Remove dispense chute, chute cover, auger tube and auger (page 10).
4. Remove drain pan, grille, dispense wheel and waterbath cover plate (page 11).
5. Clean all components and bin storage area with Solution A, rinse thoroughly with clear water and sanitize with Solution B.
6. On units with beverage valves, remove nozzles and diffusers from valves, soak for at least 10 minutes in cleaning Solution A, rinse, sanitize with Solution B and reinstall.
7. For units without integral beverage cooling, clean area below wheel and stainless cover plate with Solution A, rinse and sanitize with Solution B.
8. For models with integral ice-waterbath beverage cooling only:
 - Lower drain tube found on utility connection side of dispenser and drain ice-waterbath
 - Use a bottle brush to clean coils with Solution A, rinse and sanitize with Solution B
 - Reposition waterbath drain line in UP position
 - Pour 3.5 gallons (13L) Solution A into waterbath
 - Turn power ON and tape dispense lever or dispense button back in "Dispense" position
 - Allow pump to run for 2 minutes to clean pump and pump lines
 - Turn power OFF and remove tape
 - Drain bath and replace drain tube in UP position to avoid siphoning waterbath water

Putting unit back in service after quarterly cleaning

1. On units with integral beverage cooling, fill ice-waterbath with 3.5 gallons (13L) potable water.
2. Reassemble components.
3. For manual load units, fill unit with an approved ice (page 2).
4. For automatic load units with R4A/W (R12 refrigerant) icemakers, turn icemaker switch(es) and dispenser power switch to ON position and allow storage area to fill.
5. For automatic load units with R5A/W (R22 refrigerant) icemakers, turn bin signal switch(es) and dispenser power switch to ON position and allow storage area to fill.
6. Push dispense button or lever to test that dispenser is functioning properly.

Quarterly cleaning of icemaker system

Units equipped with icemakers require cleaning of icemaker system at least every three months, and more often if local water conditions dictate. Failure to clean icemaker system will result in decreased performance and potential damage to icemaker. Refer to Icemaker Operation and Service Manual.

All manual load models before serial #40600

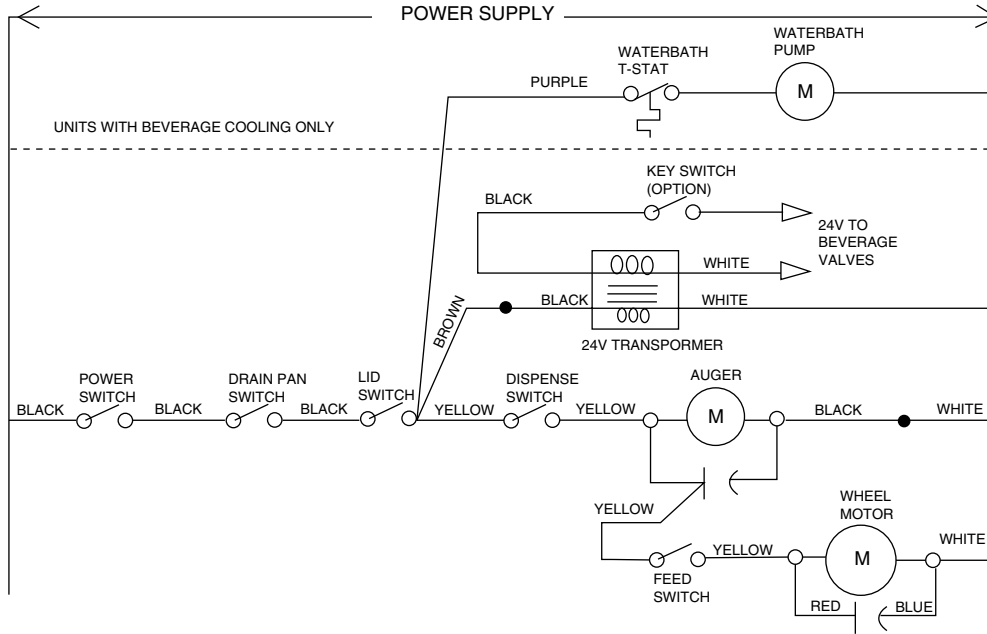

Automatic load models with R4A/W (R12) icemaker(s), no beverage cooling – Before serial #40600

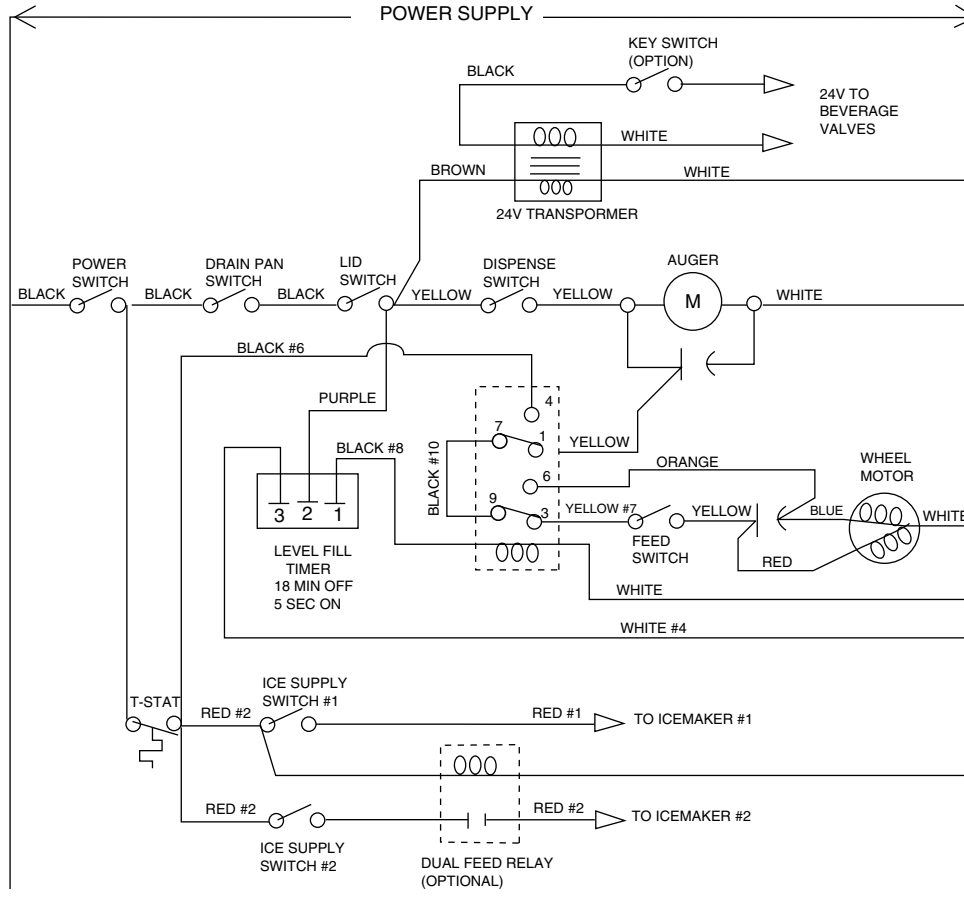

Wiring Diagram – Automatic load models with R5A/W (R22 refrigerant) icemaker (s), no beverage cooling – Before serial # 40600

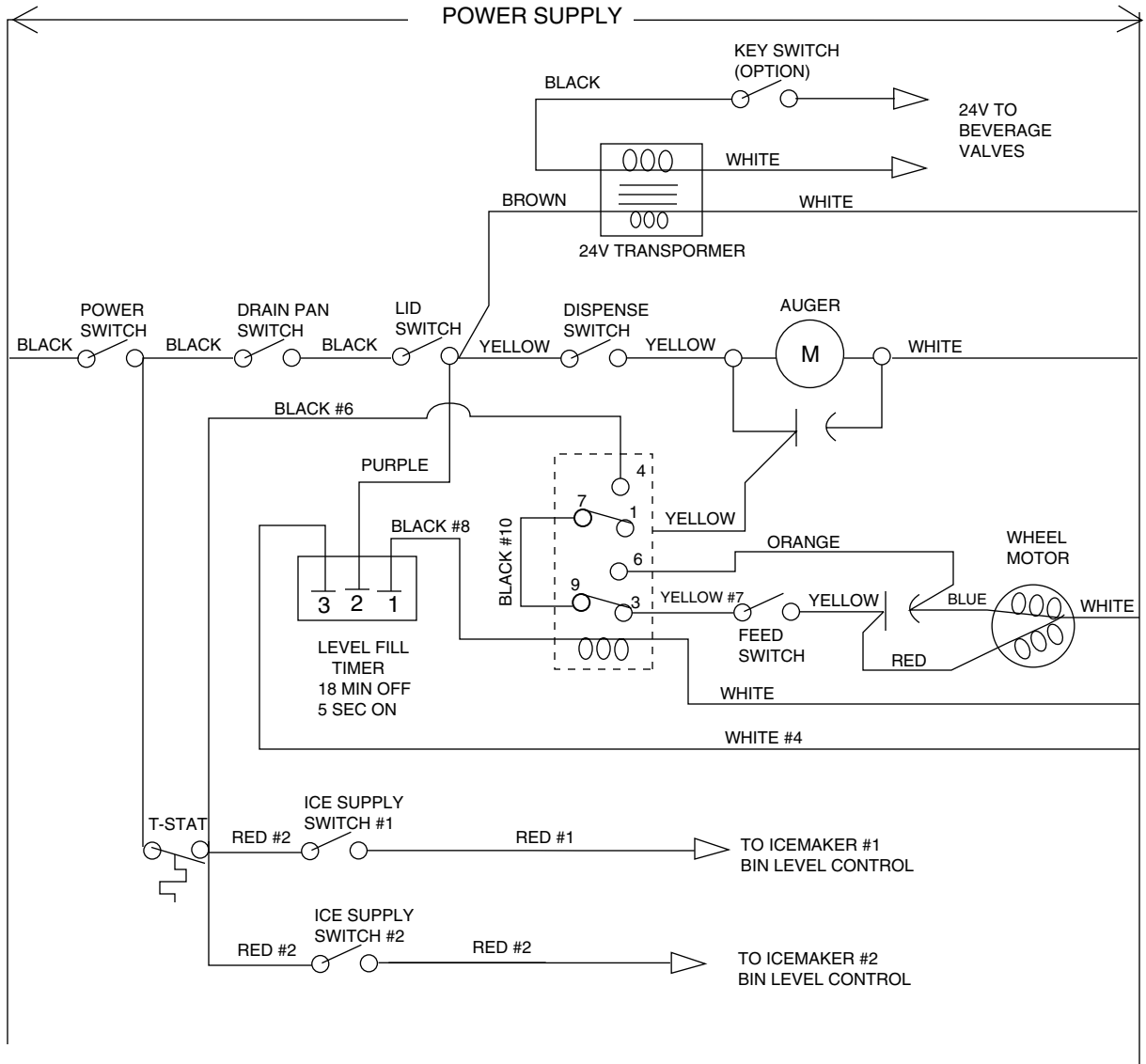

**Automatic load models with R4A/W (R12) icemaker(s), with beverage cooling –
Before serial #40600**

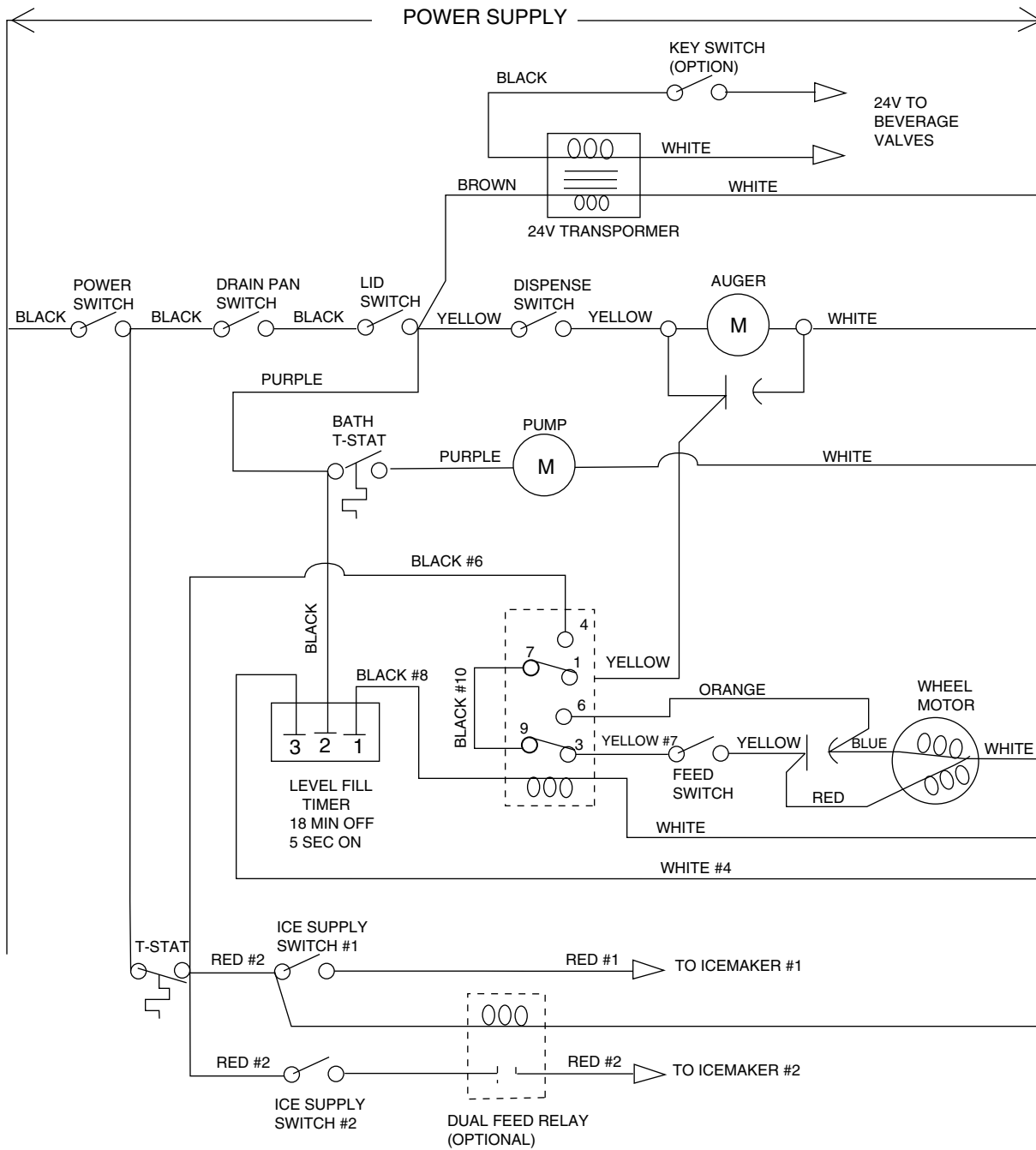

**Automatic load models with R5A/W (R22) icemaker(s) and beverage cooling –
Before serial #40600**

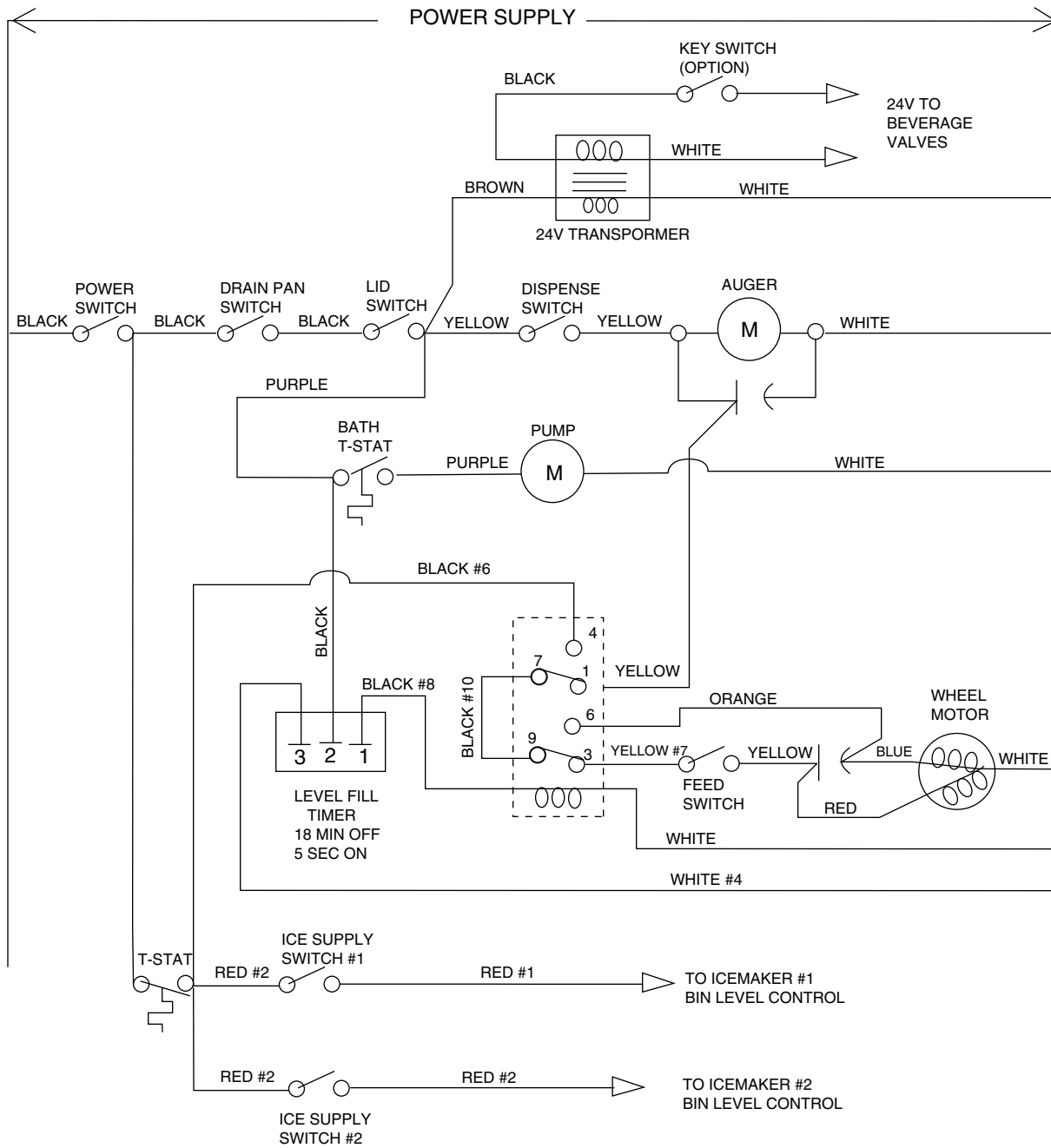

All Models – serial #40600 and up

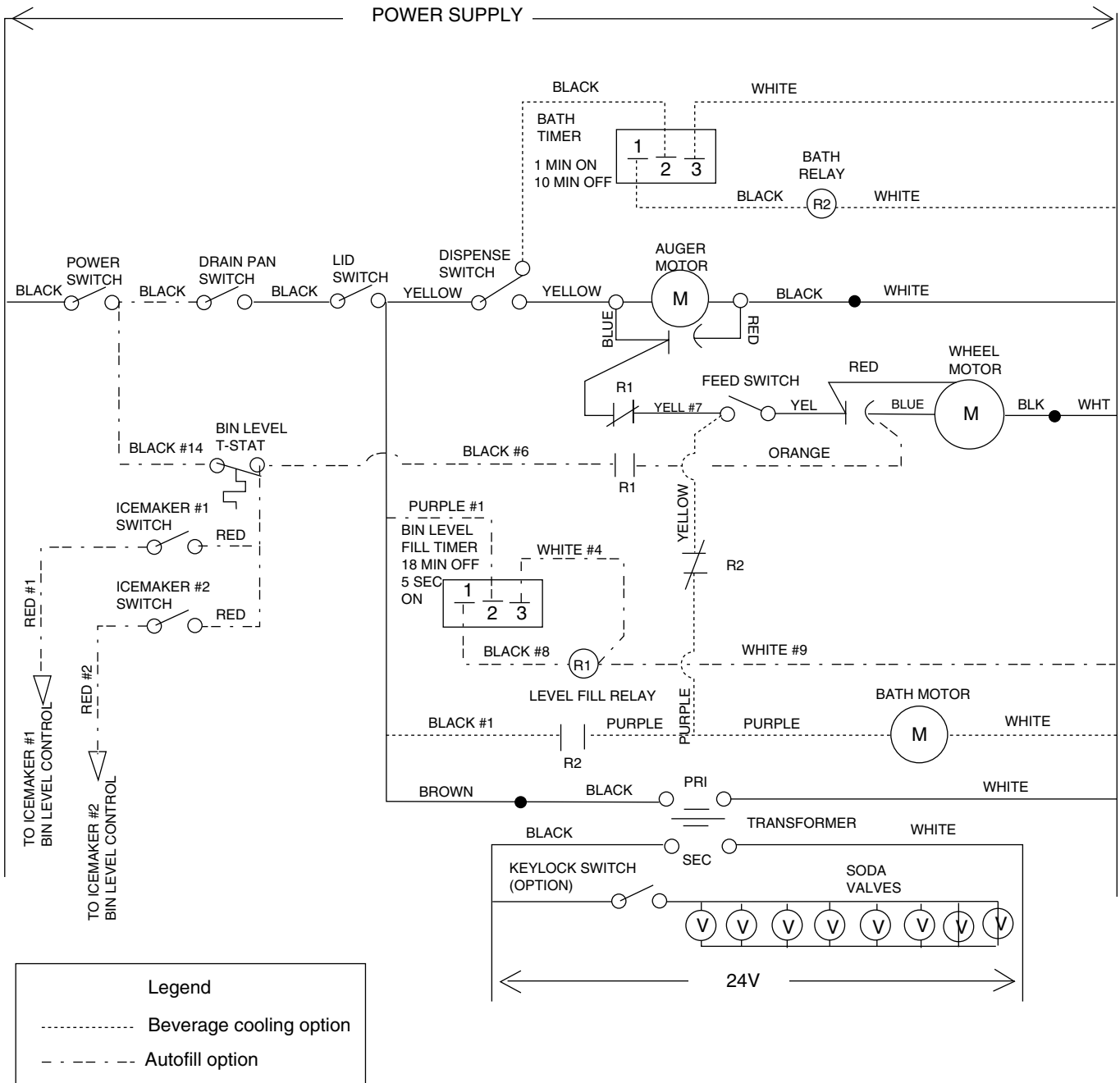

Instructions for disassembly required for periodic cleaning



Dispense chute cover removal

1. Remove ice tower cover.
2. Push in on both sides of black plastic chute cover to clear upper and lower pins.
3. After clearing pins, pull chute cover forward to remove.



Dispense chute assembly removal

1. Remove chute cover (see instructions at left).
2. Remove thumbnut holding dispense chute assembly and pull assembly forward.
3. Disconnect electrical connector and pull dispense chute assembly free of tower.



Auger motor and bracket removal

1. Remove dispense chute cover and dispense assembly (see above).
2. Remove two rear thumbnuts on motor bracket.
3. Lift motor bracket up and unplug electric quick disconnects.
4. Remove motor and bracket assembly.

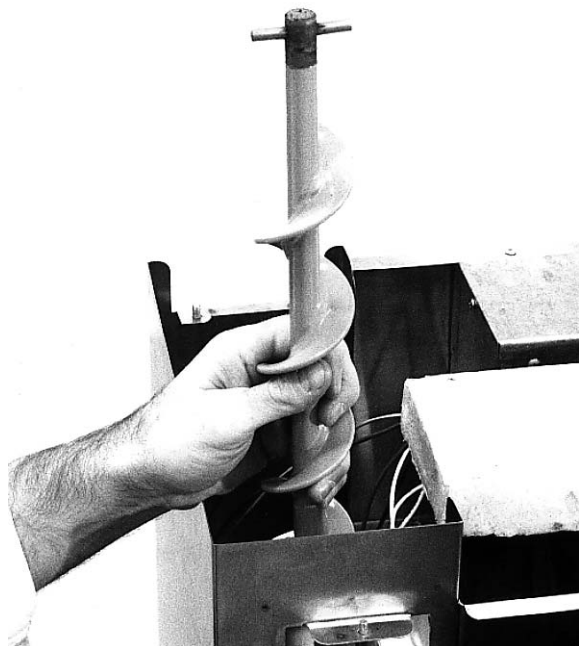

Auger and auger tube removal

1. Remove auger motor and bracket assembly (see instructions at left).
2. Pull auger upward to clear auger tube.
3. Remove auger tube bearing plate located on bottom of auger tube.
4. Lift auger tube upward to clear dispenser top.

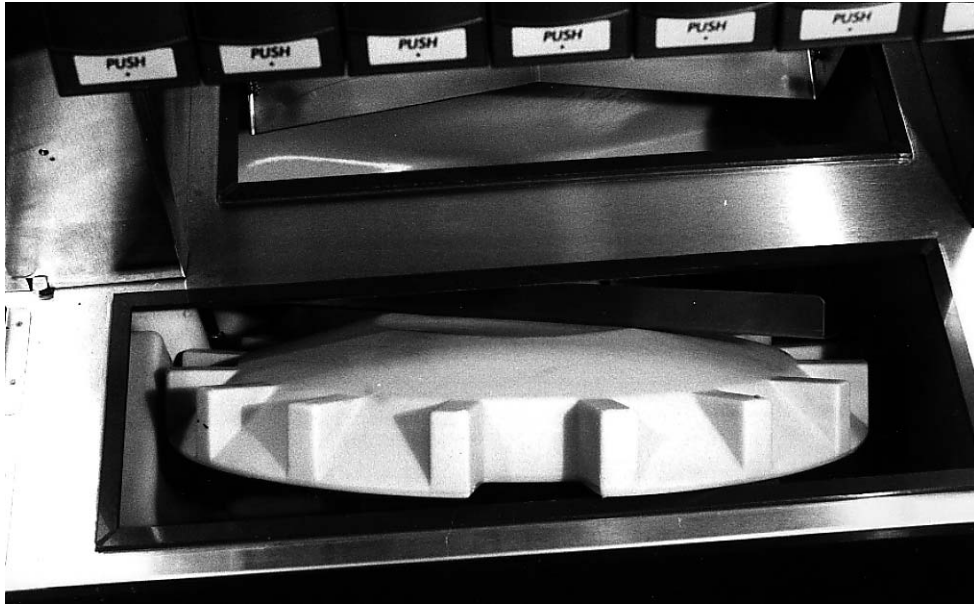

Dispense wheel and waterbath bath cover removal

1. Remove grille and drain pan assembly.
2. Remove center thumbnut and threaded rod on dispense wheel assembly and lift wheel out front (see photo above).
3. Remove two (2) screws holding bath cover in place and lift cover out front.

Disassembly instructions for service requirements only – NOT required for any cleaning procedure.

Wheel motor removal

1. Remove dispense wheel and ice-waterbath cover plates (see instructions above).
2. Remove spacer and shaft seal.
3. Lift motor bracket up and unplug electric quick disconnects.

Ice-waterbath pump motor removal

1. Remove wheel motor.
2. Drain ice-waterbath by lowering drain tube on utility connection side of dispenser.
3. Slice insulation enough to expose hose clamps on intake, output and recirculating system fittings.
4. Loosen clamps and pull tubing off fittings.
5. Loosen screws on pump motor bracket.
6. Slide pump bracket off mounting screws.
7. Disconnect electric wires from pump and remove pump.

Service and parts

Before calling for service

1. Check that ice is in dispenser and that congealed cubes are not causing a jam.
2. Check that circuit breaker and switches are in ON position.
3. Check that front drain pan and rear lids are on securely. If ajar, neither dispenser nor valves will operate.
4. Check that all drains are clear.
5. For units equipped with Follett compressed nugget icemaker, see Icemaker Operation and Service Manual for service and troubleshooting information.

Dispenser troubleshooting guide

Symptom	Possible cause	Solution
Ice does not dispense when switch is actuated. <ul style="list-style-type: none"> • Auger motor does not run • Wheel motor does not run 	<ol style="list-style-type: none"> 1. Dispense chute out of position or faulty dispense switch. 2. Front drain pan or rear lid ajar. 3. Faulty lid safety switch or drain pan switch. 4. Power switch faulty or in OFF position. 	<ol style="list-style-type: none"> 1. Check that dispense chute lever contacts dispense switch rod, or replace switch. 2. Check drain pan and rear lid. 3. Check lid safety switch and drain pan switch. 4. Check power switch.
Ice does not dispense. <ul style="list-style-type: none"> • Auger motor does not run • Wheel motor runs 	<ol style="list-style-type: none"> 1. Faulty auger motor. 2. Chain off auger sprocket. 3. Faulty run capacitor. 	<ol style="list-style-type: none"> 1. Check auger motor. 2. Check chain and sprocket. 3. Check run capacitor.
Ice does not dispense. <ul style="list-style-type: none"> • Auger motor runs • Wheel motor does not run 	<ol style="list-style-type: none"> 1. Feed switch faulty or in OFF position. 2. Faulty wheel motor. 3. Faulty run capacitor. 4. Serial #40600 and up only, faulty level fill relay. 	<ol style="list-style-type: none"> 1. Check feed switch. 2. Check wheel motor. 3. Check capacitor. 4. Check relay.
Warm drinks or soda foaming.	<ol style="list-style-type: none"> 1. No ice in storage bin. 2. Water siphoned out of ice-waterbath. 3. Faulty circulating pump. 4. Serial #40600 and up only, faulty bath timer. 5. Serial #40600 and up only, faulty bath relay. 	<ol style="list-style-type: none"> 1. Fill storage area with ice or check icemaker operation. 2. Check that ice-waterbath drain tube is in fixed upright position. 3. Check pump. 4. Check for output on pin #1 at 10 min. intervals. 5. Check relay.
Beverage valves not operating.	<ol style="list-style-type: none"> 1. Faulty 24V transformer. 2. Power switch faulty or in OFF position. 3. Drain pan or lid switch faulty or not depressed. 4. Beverage key switch locking out access. 	<ol style="list-style-type: none"> 1. Check transformer. 2. Check power switch. 3. Check switch and placement of drain pan and lid. 4. Check valve lockout.

For units equipped with Follett compressed nugget icemaker, see Icemaker Operation and Service Manual for service and renewal parts information.

**U150 series with right hand tower
(shown with push-button dispense chute assembly)**



**Close up of U150 series lever
dispense chute assembly
(right hand tower)**

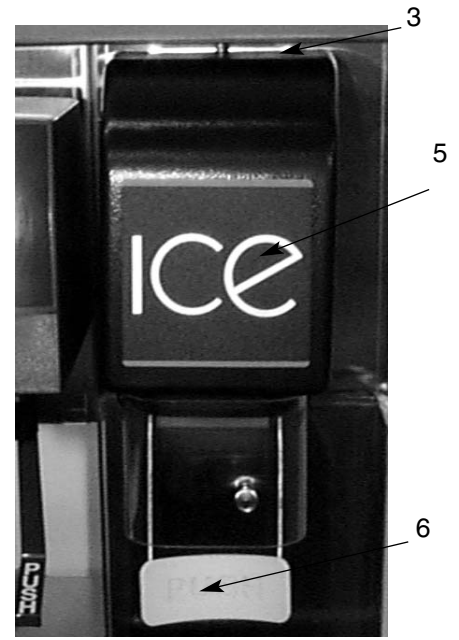

Reference #	Description	Part Number
1	Top, beverage rail and tower (includes "Follett" label)	501677
Not shown	Top, beverage rail and tower (includes "Follett" label) — 10 valve models	502127
2	Label, "Follett"	501345
Not shown	Label, "Follett" (U150N)	502341
Not shown	Label, "Follett", 10 valve models	502128
3	Cover, dispense chute, lever operation (with clear plastic extension)	501673
4	Cover, dispense chute, push-button operation (includes button)	501672
5	Label, "Ice",	501344
6	Cup guide, "Push", lever operation only	501342
7	Button, "Push for Ice"	501511
8	Ice guard, plastic (includes thumbscrews)	501674
Not shown	Thumbscrews, ice guard (10-32 x 1/2)	501100
Not shown	Backsplash assembly	502163
9	Drain pan and frame, RH, 6-8 valve, non-recessed grille	501878 & 501877
Not shown	Drain pan and frame, LH, 6-8 valve, non-recessed grille	501879 & 501877
Not shown	Drain pan and frame, RH, 6-8 valve, recessed grille	501878
Not shown	Drain pan and frame, LH, 6-8 valve, recessed grille	501879
Not shown	Drain pan, 6-8 valve, non-recessed grille	501877 & 501880
10	Drain pan, 6-8 valve, recessed grille	501880
Not shown	Drain pan, 10 valve, black plastic (obsolete)	502641
Not shown	Drain pan, 10 valve, gray plastic	502642
Not shown	Grill, 6-8 valve units, non-recessed grille	501675
11	Grill, 6-8 valve units, recessed grille	501877
Not shown	Grill, 10 valve units, black plastic pan	502126
Not shown	Grill, 10 valve units, gray plastic pan	502451
12	Cover, bin	501761
Not shown	Cover, bin — 10 valve models	502129
Not shown	Cover, ice storage (below drain pan) — all U150 models	502162
13	Handle, bin cover	501763
Not shown	Switch, keylock for valves	501409
Not shown	Key, beverage lock switch	501286
Not shown	Legs, 6" (153mm) adjustable to 9" (229mm) — set of 4	500880
Not shown	Fitting, male, lower drain pan	501926
Not shown	Elbow, lower drain pan	501927
Not shown	Drain pan assembly, lower	501928
Not shown	Plug, drain clean out	501929
Not shown	Water station (glass filler) U150N only	502296
Not shown	Lid, rear (U150N)	502340
Not shown	Lid, tower (U150N)	502342
Not shown	End wrap, dispense tower, RH	502139
Not shown	End wrap, dispense tower, LH	502140
Not shown	Inside wrap, dispense tower	502143

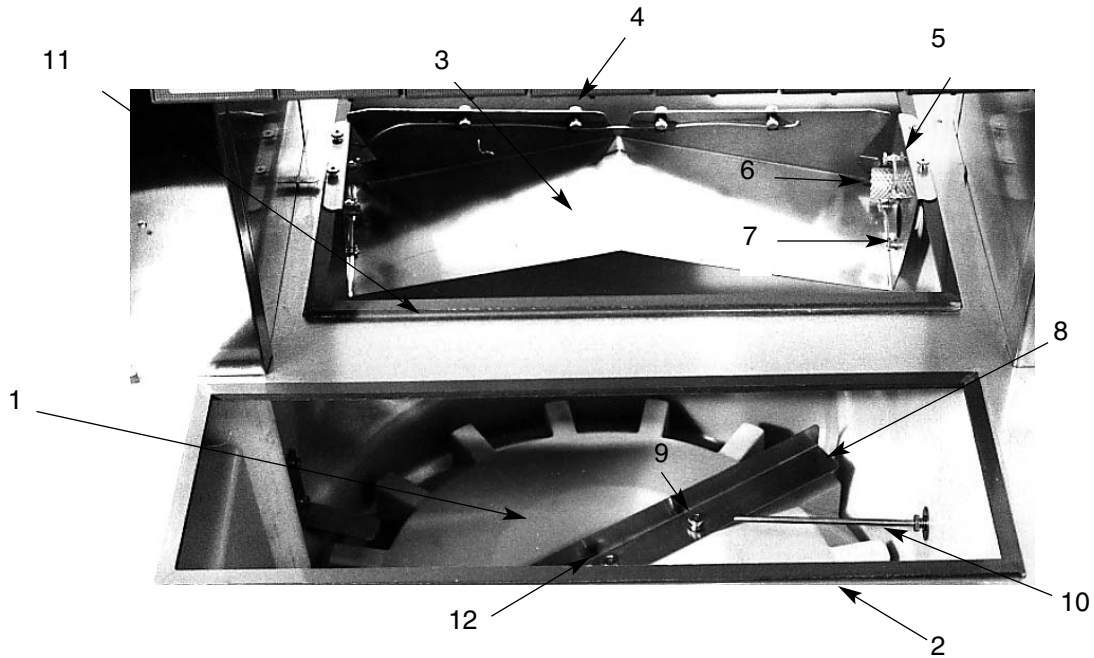

Reference #	Description	Part Number
1	Wheel, dispense, (includes 501682 and 501679)	501681
2	Lip kit, U150, front (includes adhesive)	502282
3	Plate, ice distribution (includes two 501764)	501539
4	Hardware, bin thermostat mounting	501762
5	Retaining bracket, ice tube (includes thumbnuts)	501764
6	Ice tube assembly (sold by the foot, must be ordered with 500366)	502017
7	Plate, ice tube mounting	501413
8	Agitator, rotating	501679
9	Nut, knurled, rotating agitator (2 required)	500905
10	Agitator, fixed	501678
11	Lip kit, U150 and U150 – 10 valve, rear (includes adhesive)	502283
12	Nut, knurled, dispense wheel (includes stud)	501320
Not shown	Plate, ice tube mounting (dual feed)	501412
Not shown	Drive bar, dispense wheel	501682
Not shown	Lip kit, U150N, rear (includes adhesive)	502284
Not shown	Cover, stainless steel, front opening, ice storage	502162

Reference #	Description	Part Number
13	Auger, vertical	501524
14	Auger tube, LH tower (includes 501696)	501670
Not shown	Auger tube, RH tower (includes 501696)	501671
Not shown	Bearing and plate, auger tube	501696
Not shown	Kit, ice tube entry (to convert to opposite side)	501496
Not shown	Kit, conversion (to convert 150 automatic unit to unit with dual icemakers)	501521

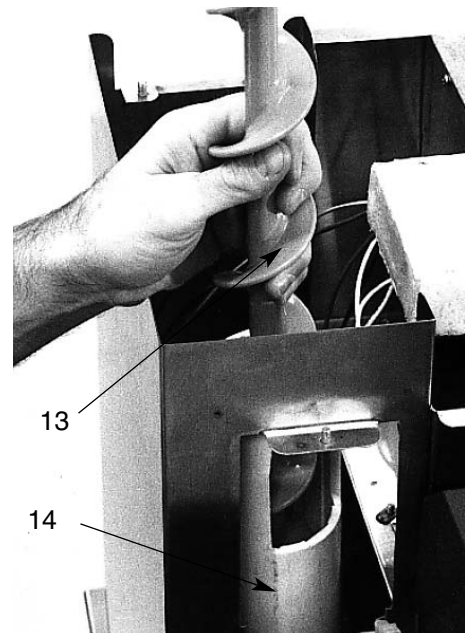

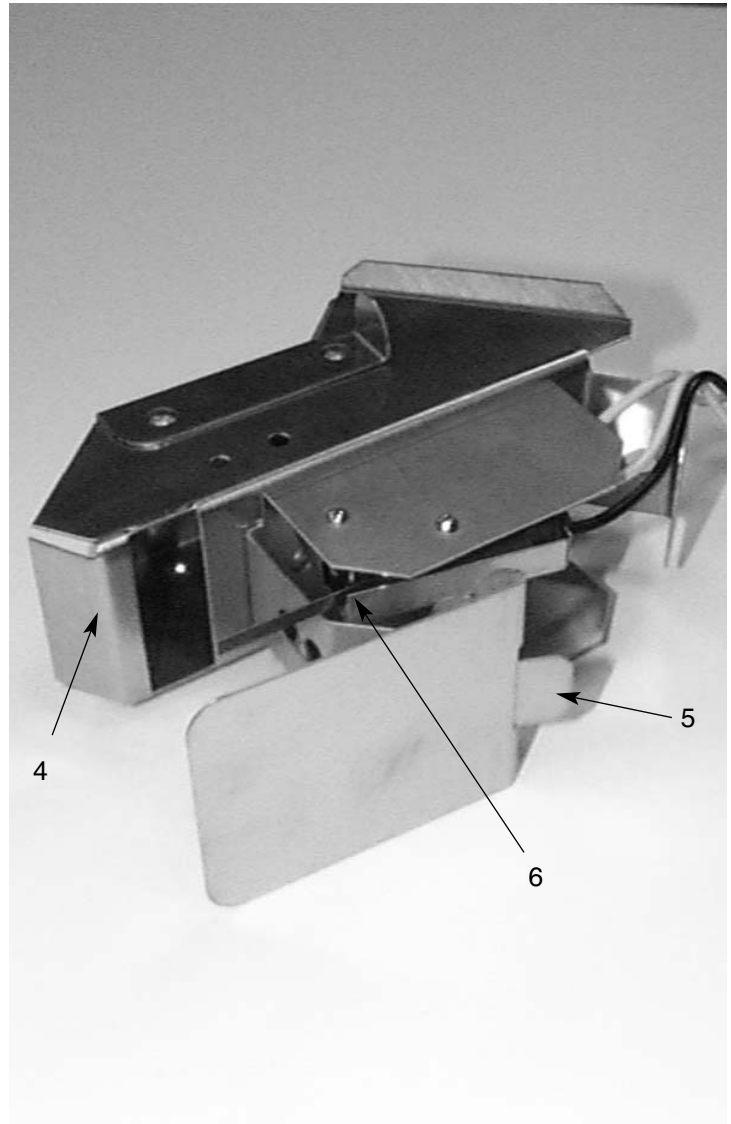
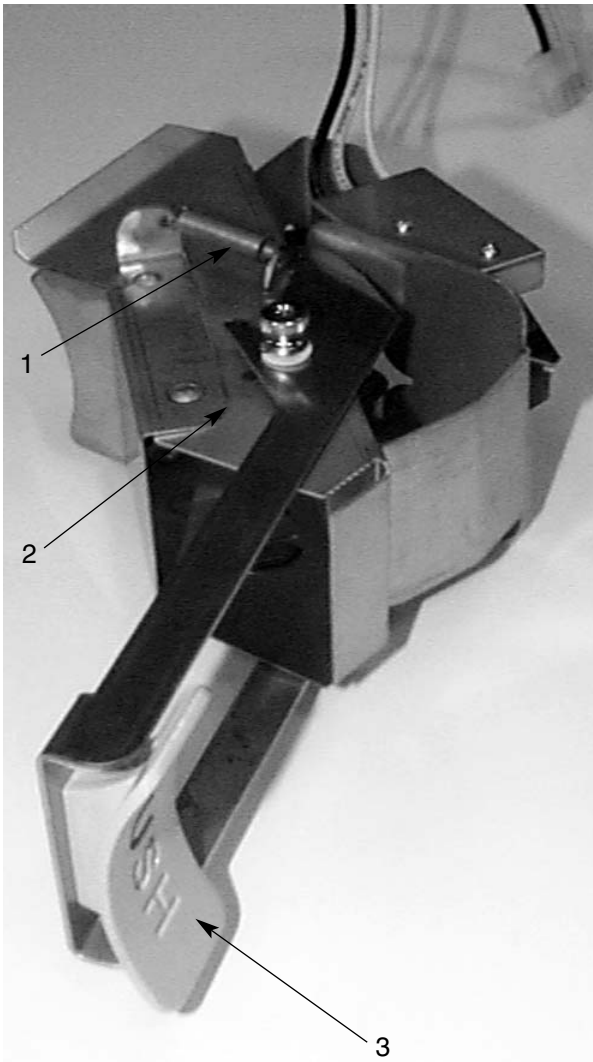

Reference #	Description	Part Number
1	Spring, lever dispense mechanism (2 needed)	501460
Not shown	Dispense chute, lever operation – LH	501688
2	Dispense chute, lever operation – RH	501689
3	Cup guide, “Push”, lever operation	501342
Not shown	Dispense chute, push-button operation – LH	501690
4	Dispense chute, push-button operation – RH	501691
5	Spring, push-button dispense mechanism	501783
6	Switch, dispense	501686
Not shown	Thumbnut 10-32 (secures dispense chute to front)	500905

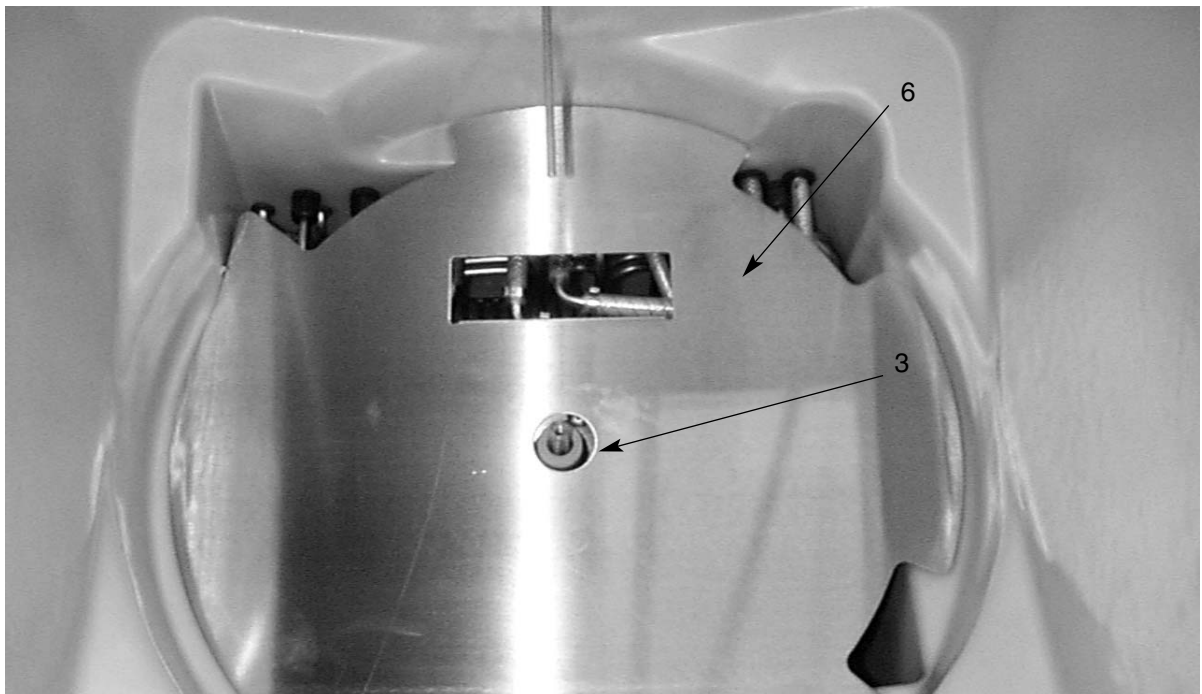
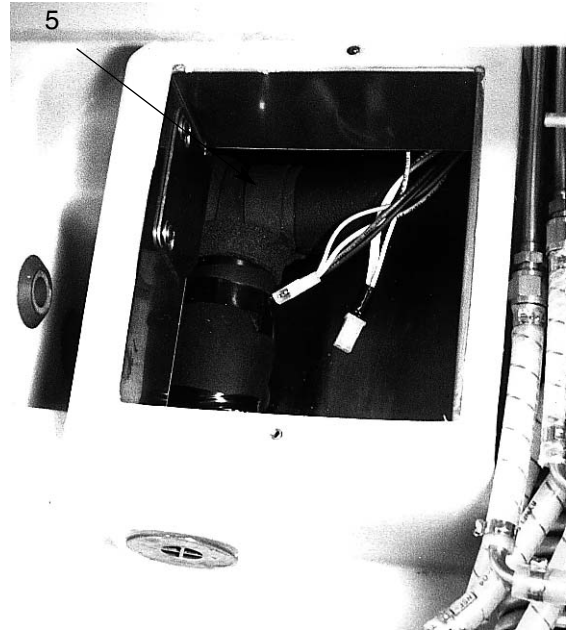
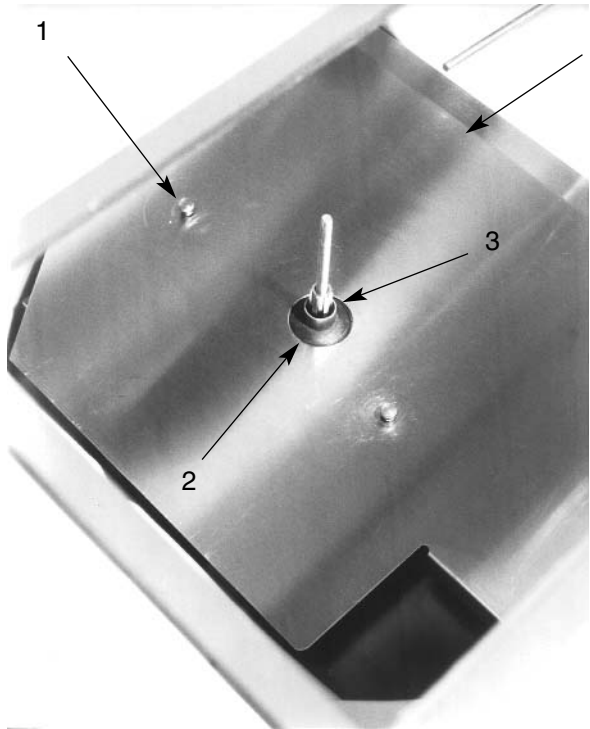

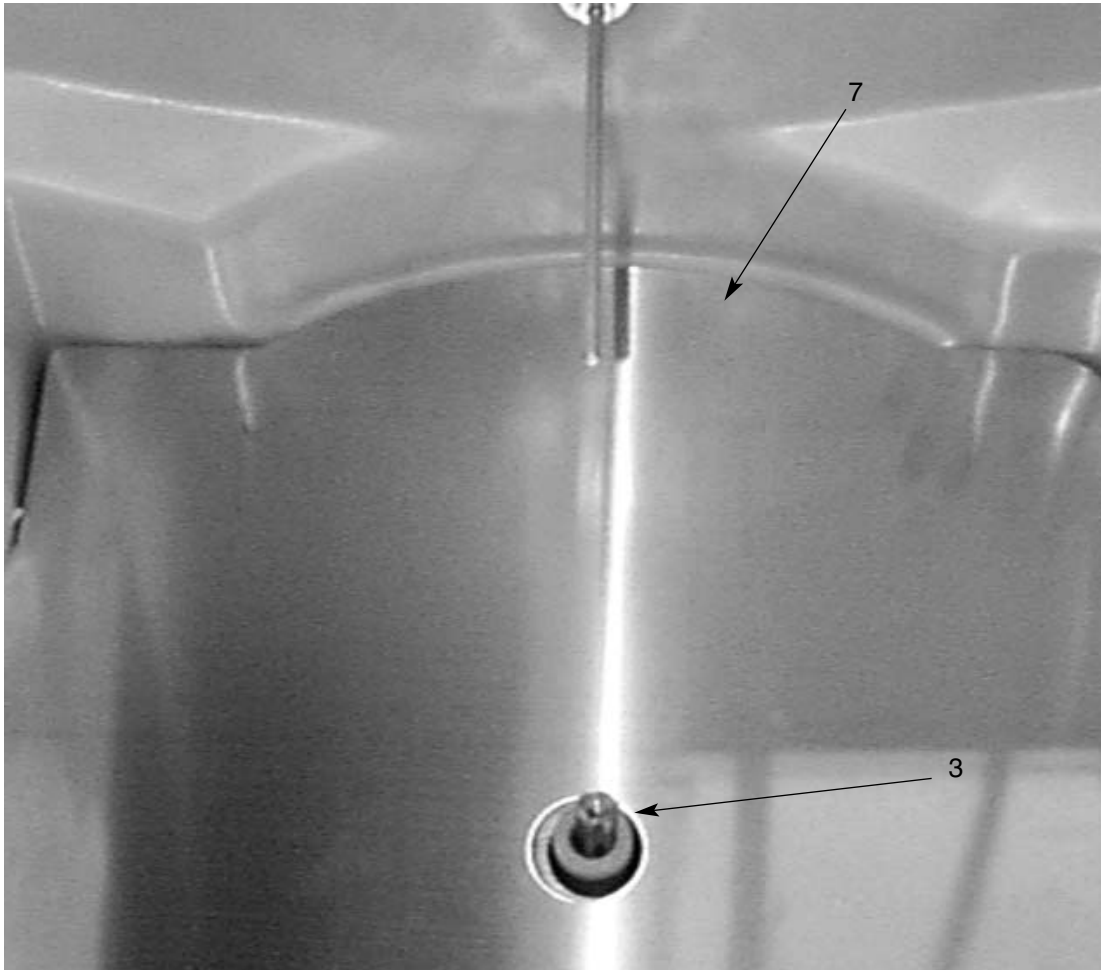

Reference #	Description	Part Number
1	Thumbscrew, 10-32 x 3/4	501766
2	Seal, shaft, wheel motor	501333
3	Spacer, wheel motor	501768
4	Cover, waterbath, beverage cooled units with foot mount motor – must upgrade with face mount casting and waterbath cover (Part number 501769)	
5	Pump kit (includes tubing, clamps and insulation)	501791
5	Pump motor – non-domestic units, 230V/50Hz	501377
6	Cover, waterbath, beverage cooled units with face mount motor	501706
7	Cover, waterbath, non-beverage cooled units with face mount motor	501705
Not shown	Cover, waterbath, non-beverage cooled units with foot mount motor – must upgrade with face mount casting and water bath cover (Part number 501770)	
Not shown	Tubing kit, pump motor	501687
Not shown	Coil, syrup main	502651
Not shown	Coil, syrup, 2-6	502653
Not shown	Coil, soda	502655
Not shown	Coil, soda, lower	502654
Not shown	Grommet, rubber, for coils	502652

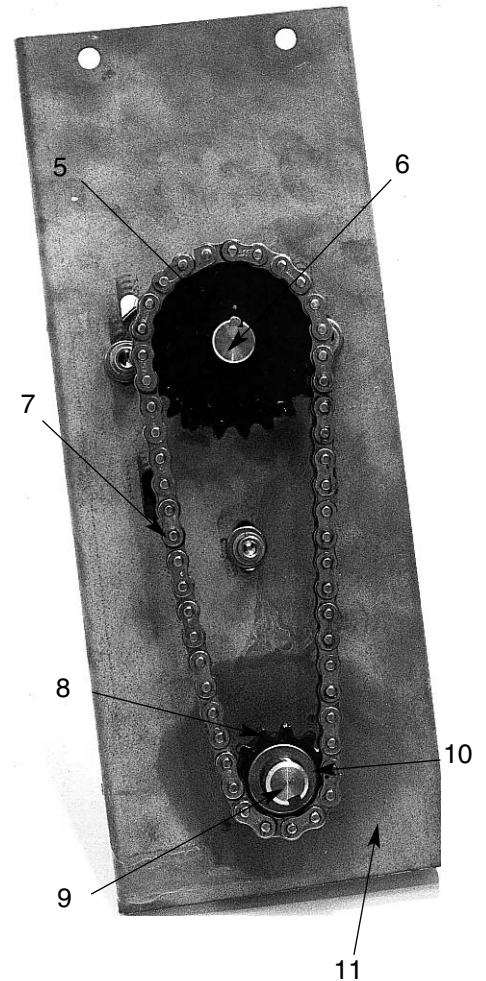
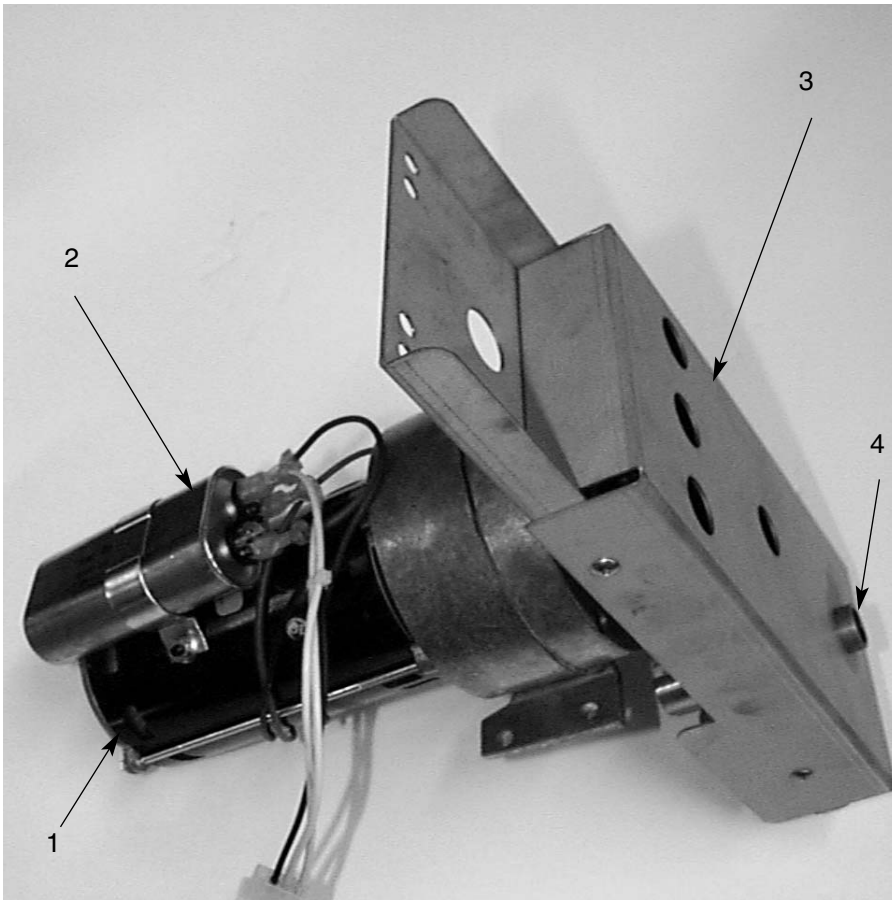

Reference #	Description	Part Number
1	Motor, auger (includes gearbox and capacitor)	501680
Not shown	Motor, auger – non-domestic units, 230V, 50Hz (includes gearbox & capacitor)	501374
2	Capacitor, auger motor (20MFD, 370VAC)	501550
Not shown	Capacitor, auger motor – Non-domestic units (4MFD, 370VAC)	501393
3	Cover and bearing, chain drive	501695
4	Bearing, auger, upper	501314
5	Sprocket 35#, 22T 5/8 bore	501552
6	Key	500367
7	Chain, auger drive	501551
8	Sprocket 35#, 12T 5/8 bore	500913
9	Drive shaft, auger	501544
10	Thrust washers (4)	501765
11	Mounting plate, auger motor (includes bearing 501314)	502166
Not shown	Thumb nut 1/4 - 20 (2 needed) (secures auger motor assembly)	500905

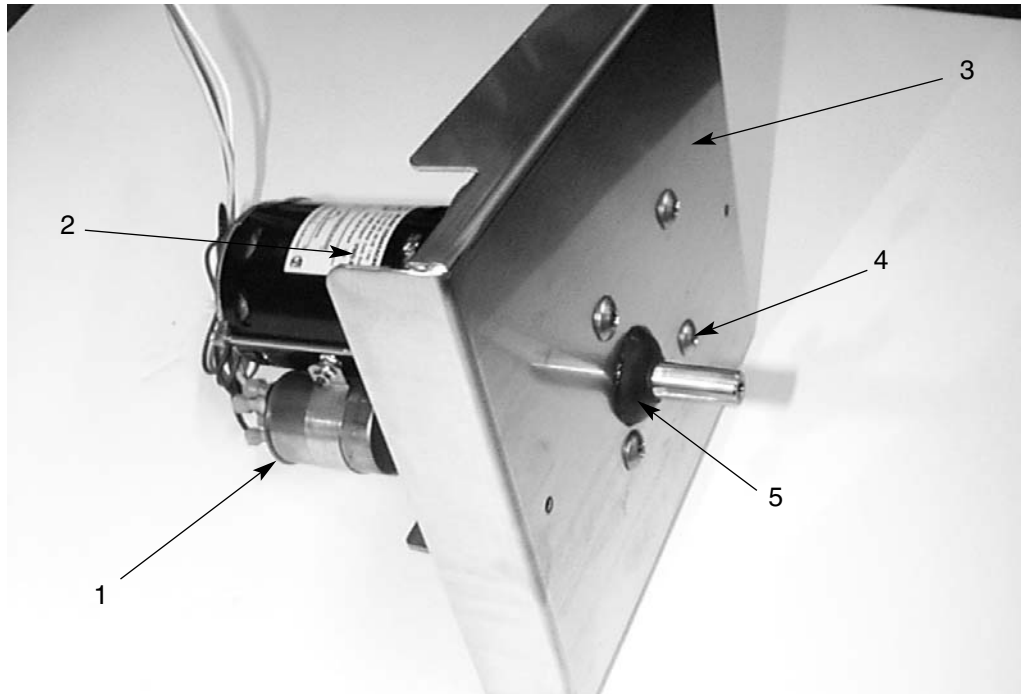

Reference #	Description	Part Number
1	Capacitor, wheel motor (12MFD, 370VAC)	501782
Not shown	Capacitor, wheel motor (4MFD, 370VAC)	501393
2	Motor, wheel, face mount (includes capacitor)	501645
Not shown	Motor, wheel, face mount – non-domestic, 230V, 50Hz (includes capacitor)	501648
3	Bracket, motor mount	501685
4	Screws (4), (to secure face mount motor to motor bracket)	501767
5	Seal, shaft, wheel motor	501333
Not shown	Spacer, wheel motor	501768
Not shown	Screws (2), 10-32x3/4, motor plate (to secure motor bracket to bin)	501766
Not shown	Face mount motor casting and waterbath cover for units with beverage cooling	501769
Not shown	Face mount motor casting and waterbath cover for non-beverage cooled units	501770

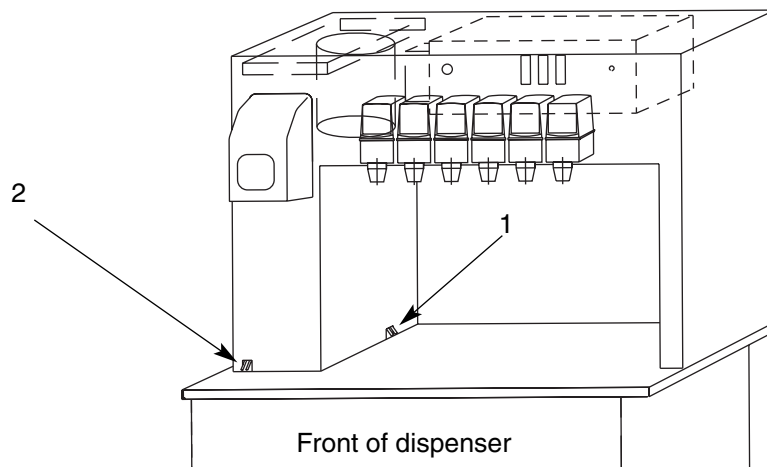

Reference #	Description	Part Number
1	Switch, lid safety – LH	501338
Not shown	Switch, lid safety – RH	501364
2	Switch, safety, drain pan – LH	501692
Not shown	Switch, safety, drain pan – RH	501693

Before Serial #40600

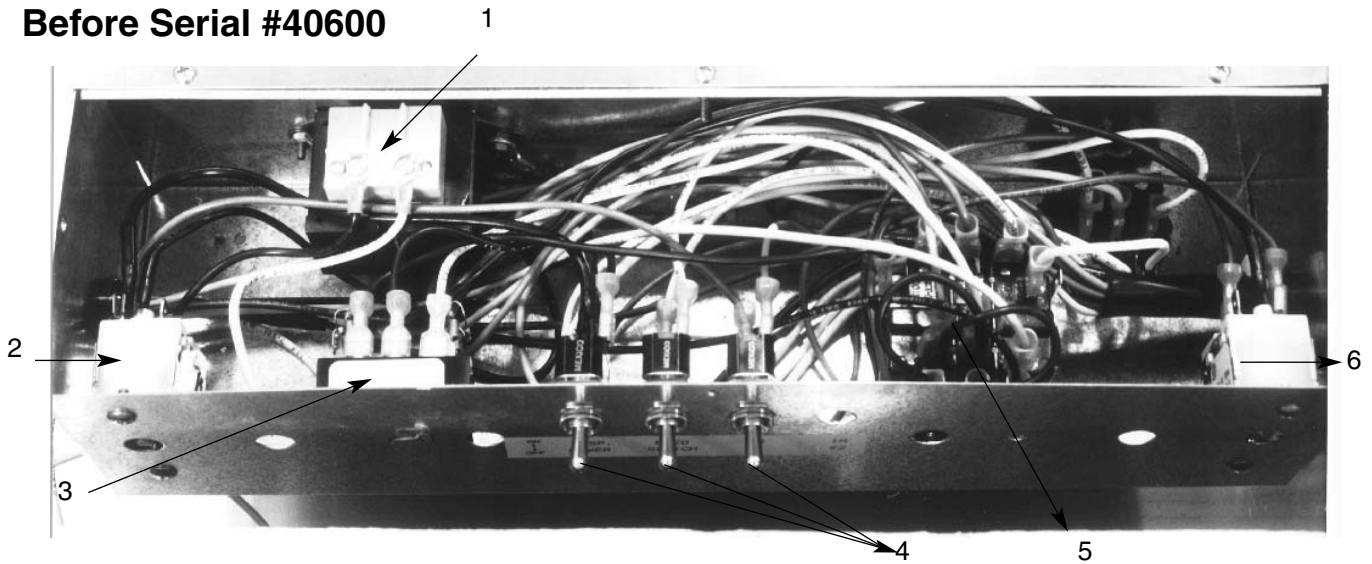

Reference #	Description	Part Number
1	Transformer, 24V, 50VA	501321
Not shown	Transformer, 24V – non-domestic units, 230V, 50Hz	501429
2	Thermostat, bin level	500514
3	Timer, level fill (automatic fill units only)	501601
Not shown	Timer, level fill – non-domestic units, 230V, 50Hz	501700
4	Switch, toggle, SPST	500006
5	Relay, level fill	501369
Not shown	Relay, level fill – non-domestic units, 230V, 50Hz	501375
6	Thermostat, pump – obsolete, must convert to timer kit	501867 or 501868
Not shown	Timer kit (to convert pump to intermittent run circuit)	501867
Not shown	Timer kit (to convert pump to intermittent run circuit) – non-domestic units, 230V, 50Hz	501868

Serial #40600 and up

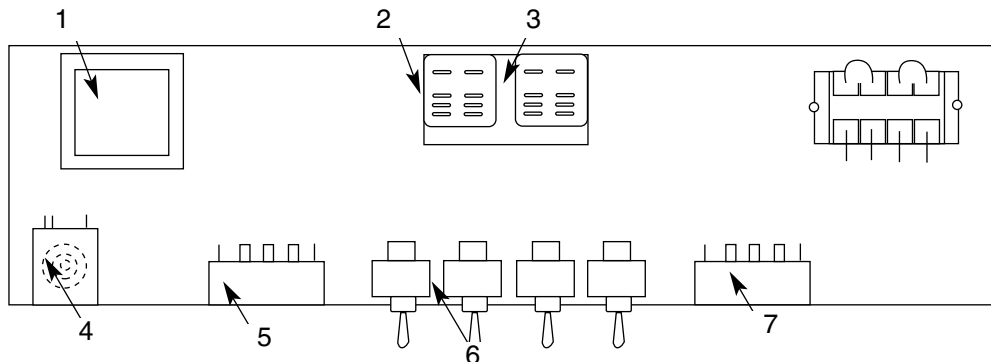

Reference #	Description	Part Number
1	Transformer, 24V	501321
1	Transformer, 24V – non-domestic units, 230V, 50Hz	501429
2	Relay, level fill	501369
2	Relay, level fill – non-domestic units, 230V, 50Hz	501375
3	Relay, beverage bath	501369
3	Relay, beverage bath - non-domestic units, 230V, 50Hz	501375
4	Thermostat, bin level	500514
5	Timer, level fill (automatic fill units only)	501601
5	Timer, level fill – non-domestic units, 230V, 50Hz	501700
6	Switch, toggle, SPST	500006
Not shown	Switch, rocker, U150N	502161
7	Timer, beverage bath	501845
7	Timer, beverage bath – non-domestic units, 230V, 50Hz	501846

