

## FOLLETT® WATER FILTER SYSTEM FOR ICE MACHINES AND ICE AND WATER DISPENSERS

---

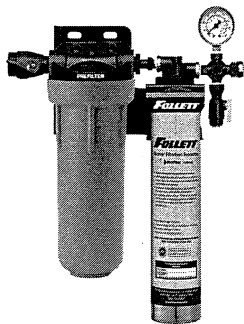

Figure 1 Follett FL4S Single System

### SELECT A MOUNTING LOCATION

---

1. Give consideration to the weight of the unit when operating (filled with water). Operating weight of the system is:
  - Follett FL4S Single System (00130229) – 13 lbs. (5.89 kg)
2. The location should allow for:
  - Minimum clearance of 2½" (6.4 cm) under the cartridge(s) so it can be lowered for removal and replacement.
  - Adequate space for "in" and "out" water line connections.
  - Be near a drain for flushing.

### INSTALLATION

---

1. Use the predrilled mounting holes in the manifold bracket as guides. Mark and drill anchor holes. Mount securely. See Figure 2.
2. Shut off power to equipment.
3. Connect outlet port of system to equipment served. Always use a NSF approved pipe dope or Teflon® tape at all connections. Use a backup wrench on all fittings while connecting to avoid excessive stress on the system components.
4. Install a manual shut-off valve leading to the system for servicing.
5. Connect minimum 3/8" water line to the Follett FL4S Single System inlet.
6. Connect tubing to flushing valve and run to drain. The cross fitting has a flushing valve installed on the bottom.
7. Shut off the system inlet valve located on the inlet of the prefilter head.
8. Check to be sure the o-ring on the prefilter housing is sufficiently lubricated. Use a good grade of silicone lubricant, if needed. Position the prefilter cartridge on guide seat in the bottom of the housing. Then thread the prefilter housing into the head by hand. Use a sump wrench to snug the housing onto the head.
9. Install the FL4S filter cartridge into the filter head following directions on the cartridge label or as shown in the Cartridge Change illustrations.
10. Turn on inlet water to the filter system and check for leaks.
11. Open the flushing valve and flush the cartridge(s) by running water through at full force for five (5) minutes. This will set the filtering media and purge any air and fines, insuring maximum filter life. See illustrations.
12. After flushing, close the flushing valve, turn on power to equipment.

**NOTE: Some municipal plumbing codes and good sanitary practices require an air gap at the drain termination point.**

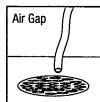

## DIMENSIONS

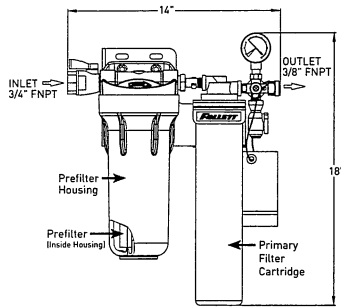

Figure 2  
Follett FL4S  
Single System

## OPERATING SPECIFICATIONS\*

COMBINED MODEL NAME	REPLACEMENT CARTRIDGE	FLOW RATE		CAPACITY <sup>†</sup>		CONNECTIONS
		GPM	LPM	GALLONS	LITERS	
Follett FL4S Single - (00130229)	Prefilter Cartridge (00130211) 1 required FL4S Plus (00130245) - 1 required	0.5	1.9	3,000	11,400	3/4" FNPT inlet 3/8" FNPT outlet

\* For individual cartridge specifications, refer to cartridge literature. <sup>†</sup>Not Performance Tested or Certified by NSF.

**Temperature:** 35 –100°F (2–38°C)

**For cold water use only.**

**Pressure:** 10 –125 psi (0.7–8.6 bar), non-shock

## NOTES

Not for residential use. For food service applications only.

Check for compliance with state and local laws and regulations. Do not use with water that is microbiologically unsafe or of unknown quality without adequate disinfection before or after the system. Systems certified for cyst reduction may be used on disinfected waters that may contain filterable cysts.

Effectively filters dirt and particles as small as ½ micron in size by mechanical means.

NSF/ANSI Standard 53 Certified to reduce Cysts such as *Cryptosporidium* and *Giardia* by mechanical means.

For installations in Massachusetts, the Commonwealth of Massachusetts Plumbing Code 248 CMR shall be adhered to, Consult your licensed plumber for installation of the system. This system and its installation must comply with state and local regulations.

## FLUSHING

For maximum life, all carbon filter cartridges must be flushed for five (5) minutes at full flow before use.

**ALL NEW CARTRIDGES MUST BE FLUSHED AFTER EACH CARTRIDGE CHANGE BEFORE BEING PUT INTO SERVICE!**

If the cartridges are new, have been properly flushed and both needle and follower register inadequate pressure, you may be experiencing inadequate water pressure or some restriction may exist in the inlet water line. In either case, the incoming water pressure must be improved to receive optimum filter life.

COMPLETE CARTRIDGE CHANGE INSTRUCTIONS CAN BE FOUND ON THE FILTER CARTRIDGE LABEL.

## CARTRIDGE CHANGE DETERMINATION

Replace the prefilter cartridge whenever it becomes excessively dirty (observed by flow restriction). Follow the change instructions provided with the cartridge. Replace carbon filter cartridges when capacity is reached, or when flow becomes inadequate, but no later than six (6) months from date of install. All carbon filter cartridges on multiple cartridge systems should be changed at the same time. The system pressure gauge provides a quick, simple means of determining when the filter cartridge(s) should be checked. Installed on the system outlet manifold, the gauge can be used to monitor both dynamic (flowing) and static (line) pressure. The cartridge(s) should be changed when the pressure gauge needle is in the red area while equipment is in operation, and yet the needle shows adequate line pressure between cycles. Observe the needle during the next equipment on cycle. If the needle registers adequate pressure, it can be assumed that the temporary low-pressure condition was caused by a brief power failure or other incoming pressure disruption. If the low pressure condition is not due to an external condition, check/change the prefilter first. If the low pressure condition is still not corrected, change the carbon filter cartridges.

## REPLACEMENT PARTS

Contact Follett Corporation at 800.523.9361 or [www.follettice.com](http://www.follettice.com) for filter cartridges.

DESCRIPTION	PART NUMBER
Prefilter Cartridge	00130211
Primary Filter Cartridge	00130245
Outlet Pressure Gauge	EV3114-09
Inlet Valve (Follett FL4S Single System)	EV3114-07
Flushing Valve	EV3102-01
O-Ring for Prefilter	151120
Prefilter Housing	153197-06



System Tested and Certified by NSF International against NSF/ANSI Standard 42 and 53 for the reduction of:

STANDARD NO. 42 — AESTHETIC EFFECTS	STANDARD NO. 53 — HEALTH EFFECTS
Bacteriostatic Effects	Mechanical Filtration Cyst
Chemical Reduction Taste & Odor Chlorine	
Mechanical Filtration Nominal Particulate Class I	

The term "bacteriostatic" indicates that the system limits the passage or growth of bacteria that may already exist in the incoming water. It does not mean that the water leaving the system is safer to drink than the water entering the system.

## PRESSURE GAUGES

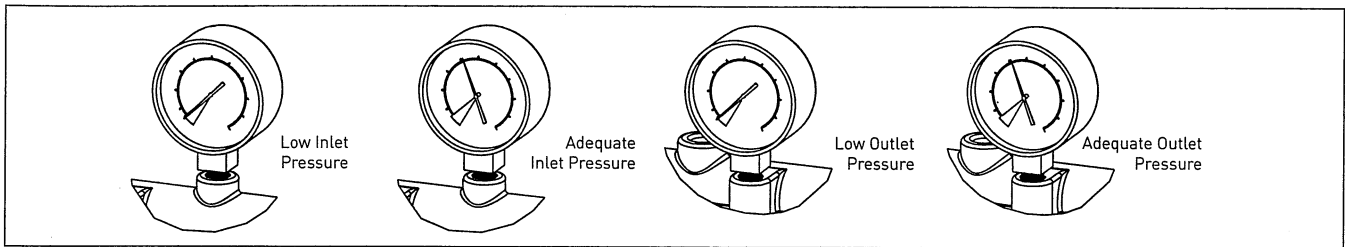

## CARTRIDGE CHANGE PROCEDURE

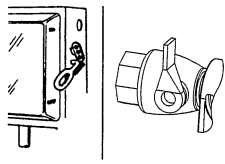
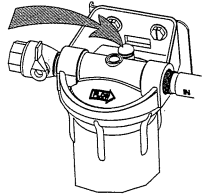
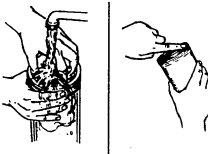
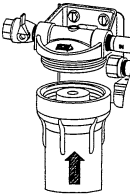
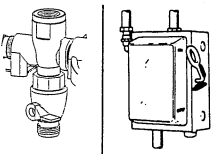
 <p><b>E-Series Prefilter Cartridge Change</b></p> <ol style="list-style-type: none"> <li>1. Shut off power to equipment. Shut off inlet water ahead of system.</li> </ol>	 <ol style="list-style-type: none"> <li>2. Push red relief valve. Unscrew bowl. Remove prefilter cartridge.</li> </ol>	 <ol style="list-style-type: none"> <li>3. Clean bowl with filtered water only; no special cleaners.</li> <li>4. Feel head o-ring. If dry, lubricate with high quality silicone lubricant.</li> </ol>	 <ol style="list-style-type: none"> <li>5. Install new prefilter cartridge in bowl. Hand tighten bowl onto head.</li> </ol>	 <ol style="list-style-type: none"> <li>6. Turn on water. Turn on power to equipment.</li> </ol>
---	---	--	--	---

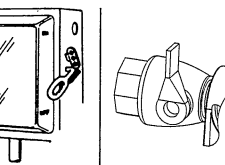
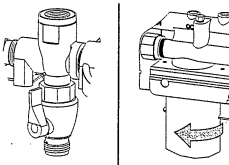
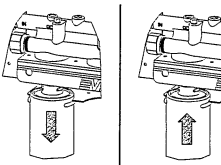
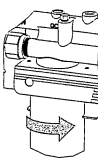
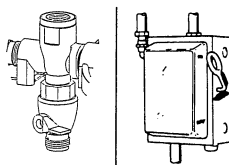
 <p><b>Everpure Carbon Filter Cartridge Change</b></p> <ol style="list-style-type: none"> <li>1. Shut off power to equipment. Shut off inlet water ahead of system.</li> </ol>	 <ol style="list-style-type: none"> <li>2. Open flushing valve to relieve pressure.</li> <li>3. Hold head firmly and push upward. Turn cartridge to left until it stops.</li> </ol>	 <ol style="list-style-type: none"> <li>4. Pull cartridge downward and out of head.</li> <li>5. Hold head firmly. Align cartridge lug with label. Insert new cartridge firmly into head.</li> </ol>	 <ol style="list-style-type: none"> <li>6. Turn cartridge right 90° until rotation stops.</li> <li>7. Repeat steps 3-6 for remaining cartridges.</li> </ol>	 <p><b>Flushing</b></p> <ol style="list-style-type: none"> <li>8. With flushing valve fully open, open inlet water at full force for five minutes. Close flushing valve.</li> <li>9. Turn on power to equipment.</li> </ol>
---	--	--	--	--

# LIMITED WARRANTY

## COMMERCIAL WATER TREATMENT EQUIPMENT

You have just purchased one of the finest water treatment units made. As an expression of confidence in this product, Pentair Filtration Solutions, LLC ("PFS") offers the following product warranty. This product is warranted against material defects in materials and workmanship to the original end-user when installed in accordance with the PFS specifications. The warranty period commences on the date of purchase and is administered as follows:

**For a period of ONE YEAR**

**Replaceable elements (i.e., filter & water treatment cartridges)\***

**For a period of FIVE YEARS**

**The entire system (excluding replaceable elements)**

The unit must be used in operating conditions that conform to PFS's recommended guidelines. This warranty will not apply if the unit has been modified, repaired or altered by someone not authorized by PFS.

If a part described above is found to have a material defect in materials or workmanship within the specified warranty period, you should notify Pentair® Everpure technical service at the phone number listed below. Any part found materially defective within the terms of this warranty will be repaired or replaced (at PFS's discretion) by your local dealer or Pentair Everpure technical service. You pay only freight from our factory and local dealer charges. Any item repaired or replaced pursuant to this warranty will be covered under the original warranty terms of the system.

PFS is not responsible for damage caused by accident, fire, flood, freezing, Act of God, misuse, misapplication, neglect, oxidizing agents (such as chlorine, ozone, chloramines and other related components), alteration, installation or operation contrary to our printed instructions, or by the use of accessories or components which do not meet PFS's specifications. Refer to the specifications section in the Installation and Operating manual for approved application parameters.

Our product performance specifications are furnished with each water treatment unit. TO THE EXTENT PERMITTED BY LAW, EVERPURE DISCLAIMS ALL IMPLIED WARRANTIES, INCLUDING WITHOUT LIMITATION WARRANTIES OF MERCHANTABILITY AND FITNESS FOR PARTICULAR PURPOSE; TO THE EXTENT REQUIRED BY LAW, ANY SUCH IMPLIED WARRANTIES ARE LIMITED IN DURATION TO THE PERIOD SPECIFIED ABOVE FOR THE ENTIRE WATER TREATMENT UNIT.

As a manufacturer, we do not know the characteristics of your water supply or the purpose for which you are purchasing this product. The quality of water supplies may vary seasonally or over a period of time, and your water usage rate may vary as well. Water characteristics can also differ considerably if this product is moved to a new location. For these reasons, we assume no liability for the determination of the proper equipment necessary to meet your requirements, and we do not authorize others to assume such obligations for us. Further, we assume no liability and extend no warranties, express or implied, for the use of this product with a non-potable water source or a water source which does not meet the conditions for use described in the owner's guide or performance data sheet for this product.

OUR OBLIGATIONS UNDER THIS WARRANTY ARE LIMITED TO THE REPAIR OR REPLACEMENT (AT PFS'S DISCRETION) OF THE FAILED PARTS OF THE WATER TREATMENT UNIT, AND WE ASSUME NO LIABILITY WHATSOEVER FOR DIRECT, INDIRECT, INCIDENTAL, CONSEQUENTIAL, SPECIAL, GENERAL OR OTHER DAMAGES.

Some states do not allow the exclusion of implied warranties or limitations on how long an implied warranty lasts, so the above limitation may not apply to you. Similarly, some states do not allow the exclusion of incidental or consequential damages, so the above limitation or exclusion may not apply to you. This warranty gives you specific legal rights, and you may also have other rights which vary from state to state.

\*Warranty applies to material defects in materials & workmanship only.

EPA Est. No. 002623-IL-002

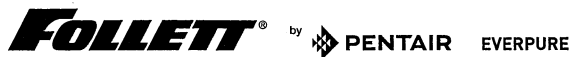

### MANUFACTURED BY PENTAIR EVERPURE

EVERPURE-SHURFLO WORLD HEADQUARTERS, 1040 MUIRFIELD DRIVE, HANOVER PARK, IL 60133 USA  
FOR

### FOLLETT

For sales, replacement components, and service, contact your Follett dealer or:

801 Church Lane • Easton, PA 18040 • Tel: 800.523.9361

[www.follettice.com](http://www.follettice.com)

EV3131-02 Rev D DE16