

Symphony Plus™ 12 Series Ice and Water Dispensers

230 V 50 Hz, 220 V 60 Hz

Operation and Service Manual
Serial numbers below K39864

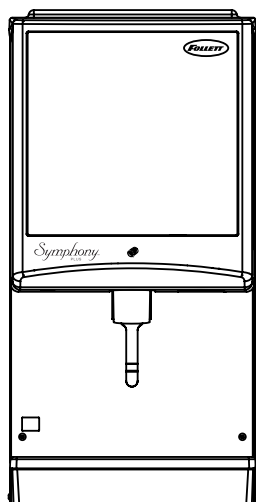

C/E12CI425A-LI
countertop, ice-only
dispenser

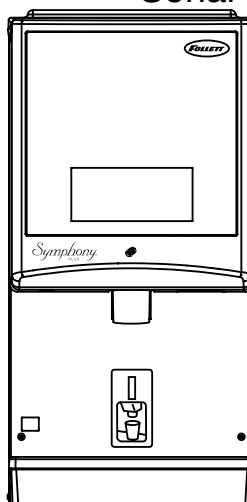

C/E12CI425A-SI countertop, ice-
only dispenser with SensorSAFE™
infrared dispensing

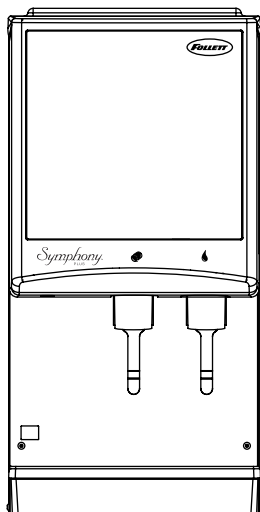

C/E12CI425A-L
countertop dispenser

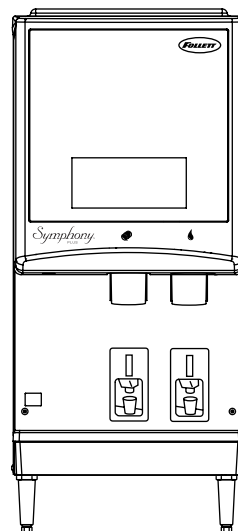

C/E12CI425A-S
countertop dispenser with
SensorSAFE infrared dispensing
(shown with legs accessory)

**Following installation, please forward this manual
to the appropriate operations person.**

Contents

Welcome to Follett	3
Before you begin	3
Specifications	4
Electrical	4
Ambient	4
Plumbing	4
Ventilation clearances	4
Dry weight	4
Installation	5
Before you begin	5
Installing countertop dispensers without legs	5
Installing countertop dispensers with legs accessory (P/N AF10LBLEGS)	6
User information	7
How the dispenser works	7
Cleaning/descaling and sanitizing	8
Weekly	8
Monthly	8
Semi-Annually (more often if conditions dictate)	8
Service	10
Ice machine operation (all models)	10
The icemaking process	10
Water system	11
Electrical system	14
Wiring diagram - 230 V 50 Hz	16
Wiring diagram - 220 V 60 Hz	18
Wiring diagram - Lever only	20
Wiring diagram - SensorSAFE only	21
Ice machine operational and diagnostic sequences	22
Diagnostic stages	28
Refrigeration pressure data	32
Compressor data	32
Gearmotor data	32
Refrigeration system	32
Dispenser troubleshooting	34
Lever model troubleshooting guide	34
SensorSAFE model troubleshooting guide	34
Disassembly and replacement instructions	36
Fan removal	39
Thermostat and ice transport tube replacement	40
Replacement parts	41
Dispenser exterior	41
Wheelmotor and drive system	42
Dispense chute and splash panel (models with lever dispensing)	43
Dispense chute and splash panel (models with SensorSAFE infrared dispensing)	44
Electrical components	45
Ice machine components	46
Compressor - 230 V 50 Hz	48
Compressor - 220 V 60 Hz	49
Evaporator replacement parts	50
Water supply and drains	52
Water treatment accessories for Symphony Plus ice and water dispensers	53

Welcome to Follett

Follett equipment enjoys a well-deserved reputation for excellent performance, long-term reliability and outstanding after-the-sale support. To ensure that this equipment delivers that same degree of service, we ask that you take a moment to review the installation portion of this manual before beginning to install the unit. Our installation instructions are designed to help you achieve a trouble-free installation. Should you have any questions or require technical help at any point, please call our technical service group at (877) 612-5086 or (610) 252-7301.

Note: To expedite assistance, all correspondence or communication **MUST** include the model number, serial number and complete and detailed explanation of the problem.

Before you begin

After uncrating and removing all packing material, inspect the equipment for concealed shipping damage. If damage is found, notify the shipper immediately and contact Follett LLC so that we can help in the filing of a claim, if necessary.

Check your paperwork to determine which model you have. Follett model numbers are designed to provide information about the type and capacity of Follett ice dispensing equipment. Following is an explanation of the different model numbers.

E12CI425A-LI

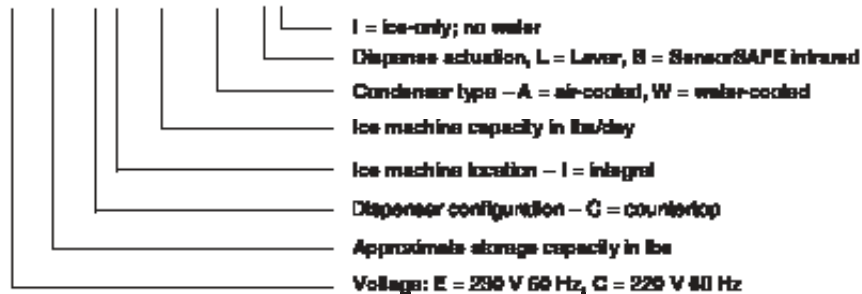

CAUTION!

- Do not tilt any unit further than 30° off vertical during uncrating or installation.
- Dispenser bin area contains mechanical, moving parts. Keep hands and arms clear of this area at all times. If access to this area is required, power to unit must be disconnected first.
- This appliance is not suitable for installation in an area where a water jet could be used.
- This appliance must not be cleaned by a water jet.
- User maintenance should not be done by children without supervision.
- Follett recommends a Follett water filter system be installed in the ice machine inlet water line (standard capacity #00130229, high capacity #00978957, carbonless high capacity #01050442).
- Prior to operation clean and sanitize the dispenser in accordance with instructions found in this manual.
- Do not block right side air intake or top air exhaust.
- This appliance should be permanently connected by a qualified person in accordance with application codes.
- A qualified person shall provide a readily accessible disconnect device incorporated into the fixed wiring.
- If the supply cord is damaged, it must be replaced by the manufacturer, its service agent or similarly qualified persons in order to avoid a hazard.
- Connect to potable water supply only.
- This appliance can be used by children aged 8 years and above and persons with reduced physical, sensory, or mental capabilities, or lack of experience and knowledge if they have been given supervision or instruction concerning use of the appliance in a safe way and understand the hazards involved. Children should be supervised to ensure that they do not play with the appliance.
- This appliance is intended to be used for household and similar applications such as staff kitchen areas in shops, offices and other working environments; farm houses and by clients in hotels, motels and other residential type environments; bed and breakfast type environments; catering and similar non-retail applications.
- WARNING!** To avoid a hazard due to instability of the appliance, it must be fixed in accordance with the instructions.
- Warranty does not cover exterior or outside installations.
- To reduce risk of shock, disconnect power before servicing.
- Ice is slippery. Maintain counters and floors around dispenser in a clean and ice-free condition.
- Ice is food. Follow recommended cleaning instructions to maintain cleanliness of delivered ice.

Specifications

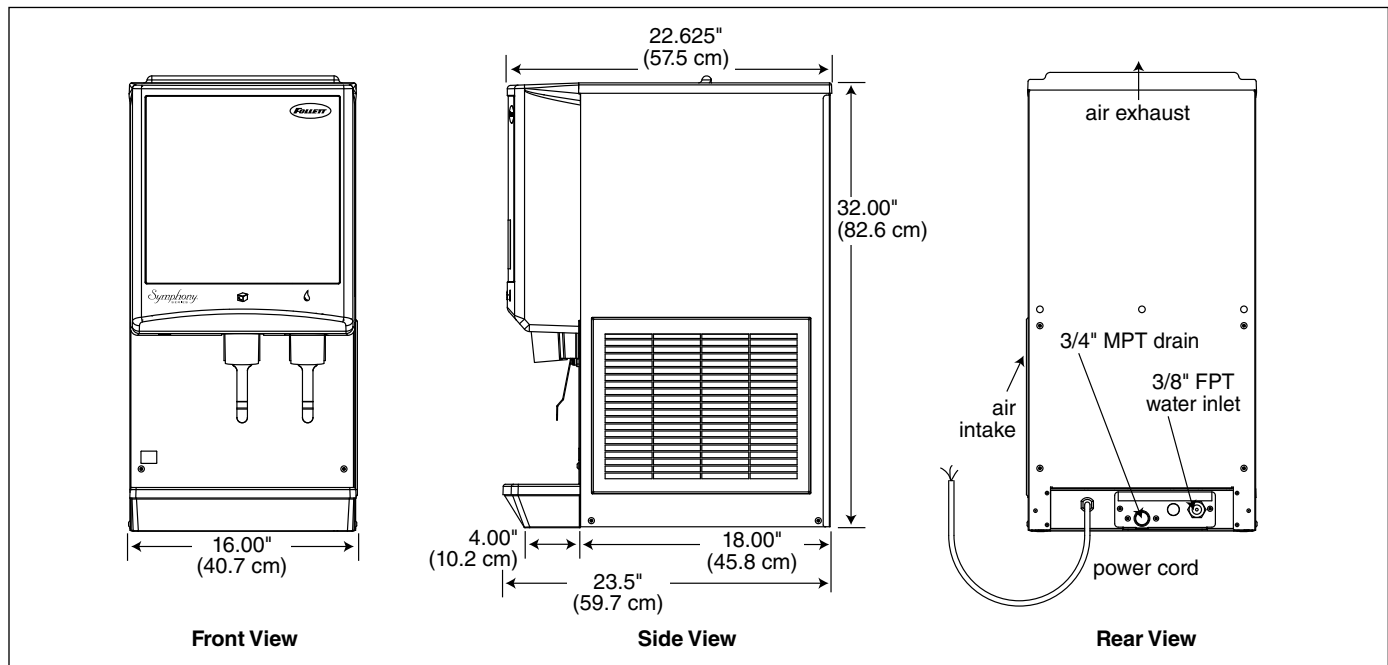

Electrical

- 230 V, 50 Hz, 1 phase, 5.5A or 220 V, 60 Hz, 1 phase, 5.5A
- Connect to a dedicated circuit.

Ambient

Air temp*	100 F/38 C Max.	50 F/10 C Min. Best performance below 80 F (27 C)
Water temp†	90 F/32 C Max.	45 F/4 C Min. Best performance below 70 F (21 C)
Water pressure	70 P.S.I./5Bar Max.	10 P.S.I./0.7 Bar Min.

* Ambient air temperature is measured at the air-cooled condenser coil inlet.

† Ambient water temperature is measured in the ice machine reservoir.

Plumbing

	12CI425A
Dispenser drain	3/4" MPT
Water inlet	3/8" FNPT

Note: Water shut-off recommended within 10 ft. (3 m) of dispenser. Drain to be hard-piped and insulated. Maintain at least 1/4" per foot (20 mm per 1 m) run of slope.

Ventilation clearances

- 6" (15.3 cm) on right side of dispenser, 6" (15.3 cm) at top for ventilation and 12" (30.5 cm) at top recommended for service.

Note: Do not block right side air intake or top air exhaust.

Dry weight

- 175 lb (79.4 kg)

Installation

Before you begin

- All dispensers must be installed level in both directions to ensure proper operation.
- Service and ventilation clearances: 6" (15.3 cm) on right side of dispenser, 6" (15.3 cm) at top for ventilation and 12" (30.5 cm) at top recommended for service.
- Countertop units installed without legs provide the option of taking utilities out bottom or back of dispenser (on wall mount units and countertop units with legs, utilities exit from back). See counter cutout drawings for bottom exiting utilities on units with and without drain pans. For installations where utilities exit through back of dispenser, refer to back view drawings.
- Counter depth must allow front of sink to be a minimum of 30.00" (76.2 cm) from wall.

Installing countertop dispensers without legs

1. Position dispenser in desired location, mark dispenser outline on counter and remove dispenser.
2. Regardless of whether utilities will exit through back or bottom of dispenser, drill four (4) 7/16" holes in counter to anchor dispenser to counter (**Fig. 1**).
3. **For utilities exiting through bottom only:**
 - (a) Make cut out as shown in **Fig. 1**.
 - (b) Move drain fitting from back of dispenser and mount where shown in **Fig. 2**.
 - (c) Cut drain tube to length and attach to barbed connection.
 - (d) Move inlet water fitting from back of dispenser and mount where shown in **Fig. 2**.
 - (e) Cut water tubing to length and re-insert into water fitting.
4. **For all units:** Apply a thick bead approximately 1/4" (6 mm) diameter of NSF-listed silicone sealant (Dow Corning RTV-732* or equivalent) 1/4" (6 mm) inside marked outline of dispenser.
5. Carefully lower dispenser on counter in proper position and secure to counter with four (4) 3/8"-16UNC bolts.
6. Smooth excess sealant around outside of dispenser.

Fig. 1

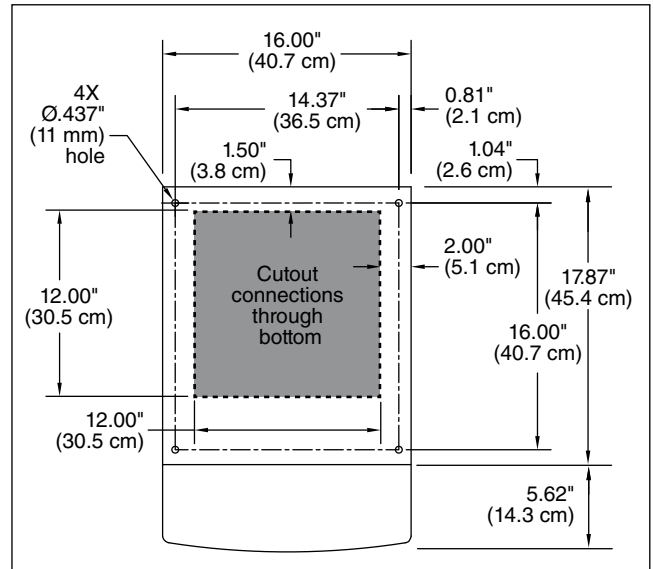
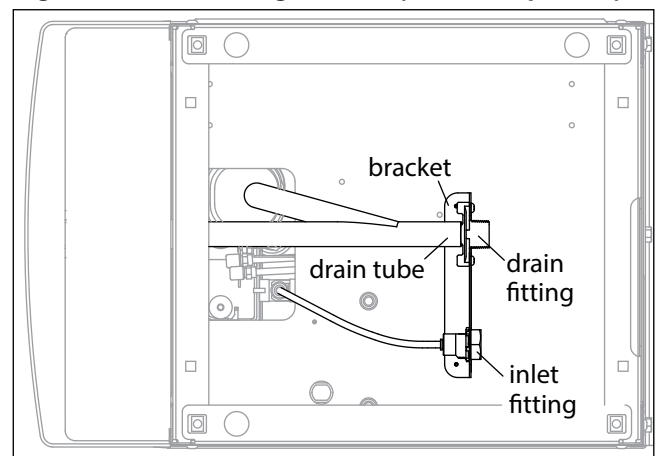

Fig. 2 - Bottom exiting utilities (countertop units)



* Dow Corning is a registered trademark of Dow Corning LLC in the United States and other countries.

Installing countertop dispensers with legs accessory (P/N AF10LBLEGS)

CAUTION!

- Do not tilt any unit further than 30° off vertical plane.
- Countertop dispensers that sit on legs (not bolted to counter) can be inadvertently moved. Care should be taken when operating and cleaning to avoid accidents.

1. Carefully tip dispenser back to expose underside and block up in place.
2. Screw legs (shipped taped to drain pan of dispenser) into dispenser bottom, taking care to seat legs securely against underside of dispenser.
3. Attach bottom panel and hardware to bottom of dispenser with supplied screws (**Fig. 3**).
4. Position unit in desired location and adjust legs to level in both directions.
5. Make final connections.

Fig. 3 - Bottom panel and leg assembly

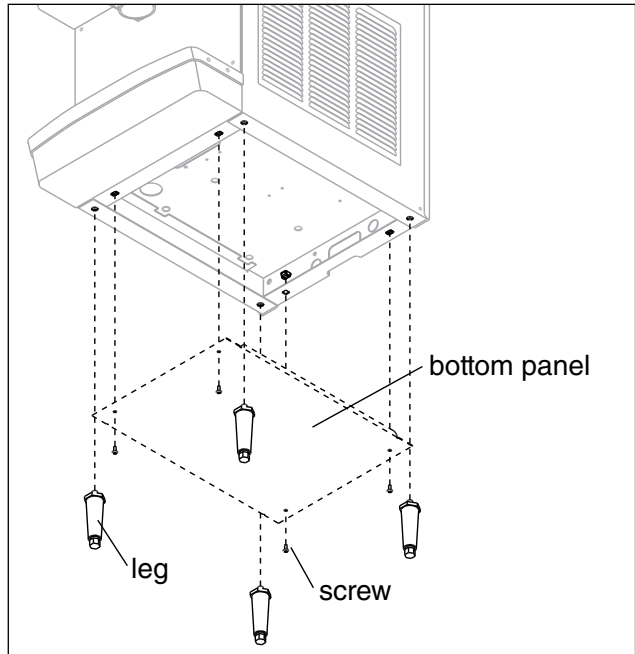

User information

How the dispenser works

Follett's 12 series automatic-load ice and water dispensers are equipped with Follett's 425 lb (193 kg)/day ice machine. In the continuous icemaking process, water freezes to the inside wall of the evaporator. A rotating stainless steel auger carries the ice to the top of the evaporator where it is compressed and extruded through an outlet port. The ice is then pushed through a tube to the storage hopper. When the hopper is full, a bin thermostat opens and shuts the ice machine off. When the dispense mechanism is activated, a dispense motor is turned on, causing the wheel to turn. This moves ice to the dispense chute where it drops by gravity into the container held below the chute.

How SensorSAFE infrared dispensing works

Follett's SensorSAFE infrared dispensing maximizes sanitation and minimizes the possibility of cross-contamination by eliminating physical contact between the cup or container and dispenser. Sensors in the panel use reflected infrared light to detect the presence of the container and send a signal to a control board which then activates the appropriate components for ice or water dispensing.

The SensorSAFE infrared dispensing package includes a cleaning switch under the left side of the front cover which temporarily shuts off dispensing to allow cleaning of the panel and lenses. If the switch is not turned back on after cleaning, the dispenser automatically resets after two minutes for normal operation.

SensorSAFE infrared dispensing also includes a time limit safety feature which automatically stops ice dispensing after one minute of continuous dispensing. Dispensing can be resumed by moving the container away from the dispenser and returning it to the activation zone.

Cleaning/descaling and sanitizing

Follett ice machines and dispensers, and their associated cleaning and sanitizing procedures, are designed for use with potable water sources. The presence, or suspected presence, of infectious agents may call for additional measures, including the replacement of components and more comprehensive disinfection measures. Follett recommends that these cleaning and sanitizing procedures be reviewed with the appropriate infectious agent subject matter experts to assure complete remediation.

Periodic cleaning/descaling and sanitizing of Follett's ice and water dispenser and ice machine system is required to ensure peak performance and delivery of clean, sanitary ice. The recommended cleaning procedures that follow should be performed at least as frequently as recommended and more often if environmental conditions dictate.

Cleaning of the condenser can usually be performed by facility personnel. Cleaning/descaling and sanitizing of the ice machine system should be performed by your facility's trained maintenance staff or a Follett authorized service agent. Regardless of who performs the cleaning, it is the operator's responsibility to see that this cleaning is performed according to the schedule below. Service problems resulting from lack of preventive maintenance will not be covered under the Follett warranty.

Recommended cleaning/descaling and sanitizing intervals*

Symphony Plus	Frequency
Drain Line	weekly
Drain Pan/Drip Pan	weekly
Exterior	as needed
Condenser	monthly (air-cooled only)
Dispenser and Components	semi-annually
Ice Machine	semi-annually
Transport Tube	semi-annually
Ice Storage Area/Bin	semi-annually

* Ice machine and dispenser must be cleaned and sanitized prior to start-up.

Weekly



- Do not use solvents, abrasive cleaners, metal scrapers or sharp objects to clean any part of the dispenser.

Dispenser drain pan and drain line

- Pour 1 gal. (3.8 L) of hot tap water into drain pan to flush drains.

Splash panel front, SensorSAFE infrared dispensing

- Deactivate dispensing by pressing and releasing clean switch located on left side of unit under top front cover.
- Clean lens and splash panel front using a soft cloth and mild, non-abrasive, non-chlorine based cleaner.
- Reactivate dispensing by pressing and releasing clean switch again.

Monthly



- Do not use solvents, abrasive cleaners, metal scrapers or sharp objects to clean any part of the dispenser.

Condenser (air-cooled ice machine only)

- Use a vacuum cleaner or stiff brush to carefully clean condenser coils of lint and debris to ensure optimal performance.

Semi-Annually (more often if conditions dictate)

- A cleaning/descaling and sanitizing procedure should always include both the ice machine and dispenser.
- Icemaking system can be cleaned/descaled in place.



CAUTION!

- Wear rubber gloves and safety goggles (or face shield) when handling cleaner/sanitizer.
- Use only Follett approved cleaners.
- It is a violation of Federal law to use SafeCLEAN Plus™ in a manner inconsistent with its labeling.
- Do not use solvents, abrasive cleaners, metal scrapers or sharp objects to clean any part of the dispenser.

SafeCLEAN Plus Solution: Mix cleaning solution of 1 gal. (3.8 L) 100 F (38 C) water and 7 oz (198 g) (one 7 oz packet) of Follett SafeCLEAN Plus.

Cleaning & sanitizing tool checklist

- (1) 1.5 Gallon (or larger) Plastic Buckets
- (2) clean cloths
- Sanitary gloves
- Safety glasses
- (2) Sani-Sponge™ (P/N 00131524 - single sponge)
- (1) Packet of SafeCLEAN Plus (P/N 01050863 - 24 packets)

Cleaning/descaling and Sanitizing Procedure

Note: Before beginning cleaning process, check drains and drain cup to ensure they are open and flowing freely.

1. If ice machine was running recently, ensure that the evaporator is completely free of ice before proceeding. If there is ice in the evaporator, complete steps 2-7 using only hot water to remove the ice then begin Cleaning/Descaling Procedure again.
2. Remove front cover and turn OFF bin signal switch.
3. Dispense all ice from storage hopper and discard.
4. Remove top of machine and hopper lid.
5. Press **CLEAN** switch. The **MAINTENANCE** light will turn on and the machine will drain. Wait for the **LOW WATER** light to turn on.
6. Remove lid from cleaning cup and fill (about 1 quart) until SafeCLEAN Plus solution overflows from the ice transport tube into the hopper. Place lid back on cup. Save remainder of the solution.
7. **CLEANER FULL** light will turn on and machine will start cleaning and sanitizing cycle then rinse three times; this process takes approximately 15 minutes.
8. While ice machine is cleaning/descaling and sanitizing, clean dispenser as follows:
 - a. Remove center thumbscrew, locking plate, two wingnuts and backing plate from front of storage hopper.
 - b. Remove stud assembly, baffle, wheel, and any remaining ice.
 - c. Remove dispense chutes from splash panel.
 - d. Submerge drain grille in SafeCLEAN Plus solution and allow to soak to remove any scale buildup.
 - e. Wipe stud assembly, baffle, wheel, inside of storage area, dispense chutes, drain grille and drain pan with damp cloth wrung out in SafeCLEAN Plus solution. Thoroughly rinse all parts with damp cloth wrung out with clean water.

Note: To avoid possible damage to motor assembly, only use a damp cloth to clean storage hopper. Do not allow water to run through motor shaft hole in bottom of hopper.

 - f. In the following order, reinstall dispense chutes, wheel, baffle, backing plate, two wing nuts, stud assembly, locking plate, and thumbscrew. (See manual for correct baffle position.)
9. Loosen Phillips-head screw on nozzle connected to evaporator. Remove nozzle from evaporator side only, leave other side of nozzle connected to transport tube.
10. Place one Sani-Sponge in remaining SafeCLEAN Plus solution.
11. Insert the sponge soaked in SafeCLEAN Plus solution into nozzle then insert a dry sponge into the nozzle.

12. Replace nozzle onto evaporator and tighten screw. Ensure drain is connected to reservoir and vent tubes are connected to evaporator drain pan.
13. Turn **ON** bin signal switch. Wait for ice to push sponges through transport tube.
14. Collect sponges from ice storage bin.
15. Replace hopper lid, machine top, and install front cover.
16. After 10 minutes, dispense all ice and discard.

Exterior Cabinet

- Clean stainless steel panels with stainless steel cleaner.

Service

Ice machine operation (all models)

Follett's ice machine consists of four distinct functional systems:

- Harvesting system
- Refrigeration system
- Water system
- Electrical control system

These four systems work together to accomplish the production and harvesting of ice. A problem in any one of these systems will result in improper operation of the entire ice production cycle. When troubleshooting the ice machine, it is important to analyze the entire system operation to determine which system is not functioning properly, then pinpoint the component within that system that is malfunctioning. Determine what corrective action must be taken before making any adjustments or replacing any components.

The icemaking process

The Maestro Plus ice machine uses a stainless steel jacketed evaporator and operates on a continuous freezing cycle. Water is supplied to the evaporator from the water reservoir where the water level is controlled by conductivity probes.

When the ice machine is running, a layer of ice forms on the interior surface of the evaporator. This ice is continuously removed by a slowly rotating (10 RPM) auger. The auger carries the ice upward into the cavity formed by the top bearing housing and the compression loop, where it is compressed to remove excess water. When the ice reaches the desired hardness it rotates within the cavity and is forced through a discharge port and compression nozzle and into the ice transport tube. The discharge tube and compression nozzle are slightly restricted to further compress the ice and produce the desired hardness.

A solid state control board located in the electrical box of the ice machine controls the normal operation of the ice machine and monitors gearmotor torque. This control board will shut down the ice machine should an over-torque condition occur. It is very important that you familiarize yourself with the operational sequences detailed in this manual before attempting to service the ice machine.

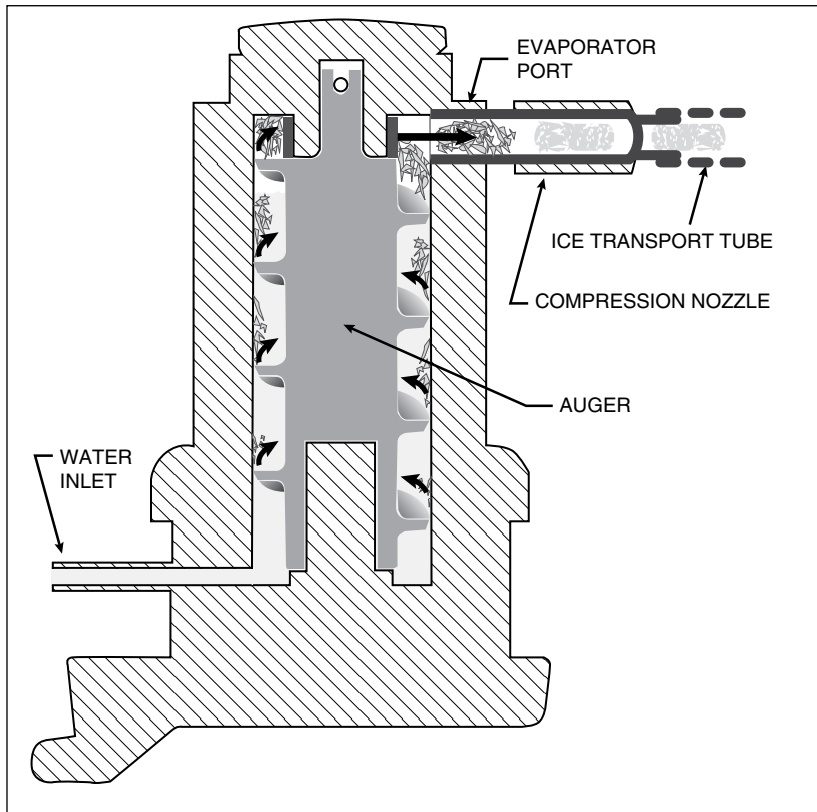

Water system

The water level in the evaporator is controlled by a fill solenoid (**Fig. 14**) and level detecting sensors. Water sensing rods (**Fig. 15**) extend down into the reservoir at the end of the evaporator assembly. The system works via electrical conductivity as follows:

One of the longest probes is a common. When water is between any of the other probes and the common, the PC board will sense the activation. During normal operation, the water level rises and falls between the Normal High and Normal Low sensors. As water is consumed to make ice, the level will fall until the Normal Low sensor is exposed, triggering the water feed solenoid on. Water will fill until the Normal High sensor is activated.

Note: The potable water dissolved solids content must be greater than 10 ppm for the water control system to function properly. If using reverse osmosis water filtration system, ensure T.D.S level is greater than 10 ppm.

Fig. 4 – Water system diagram

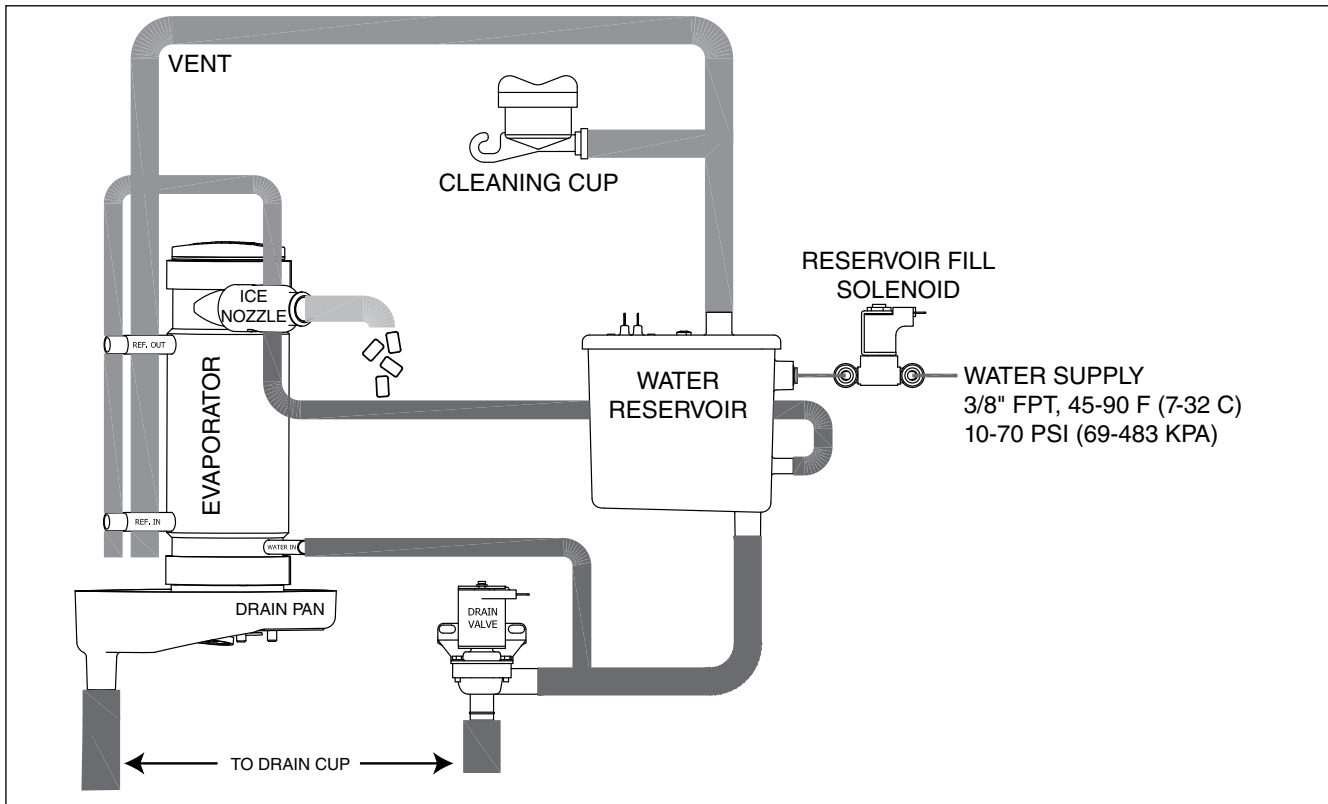
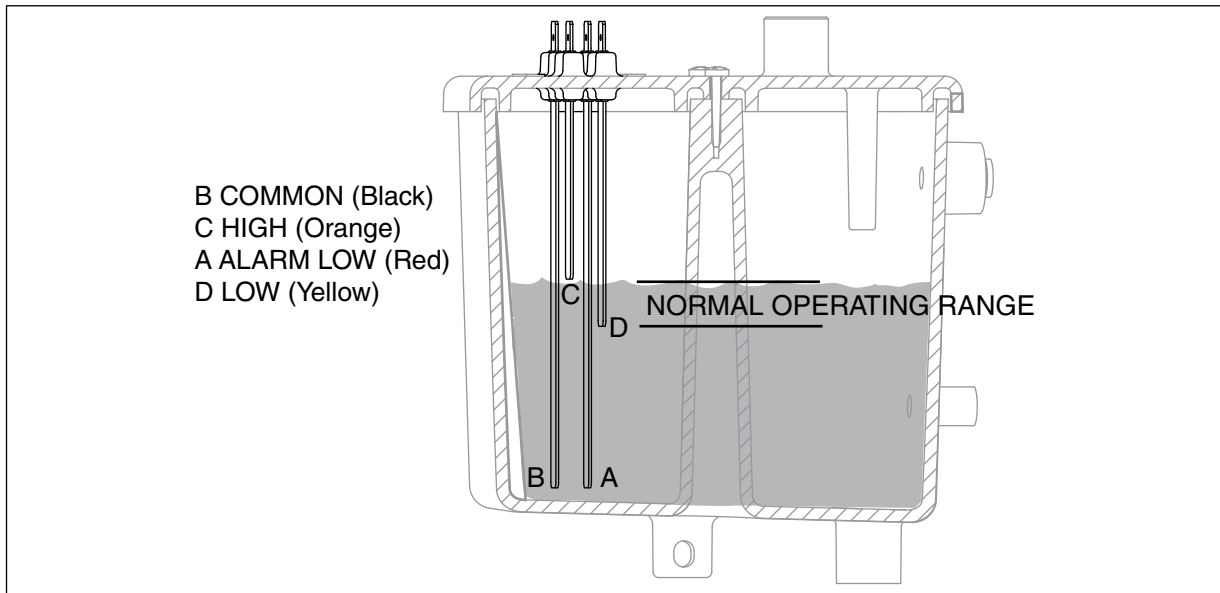

Fig. 5 – Water level diagram



Access to electrical box and control board

The 12 series electrical box has been designed to slide out for easy access to the control board and more convenient troubleshooting.

Fig. 6

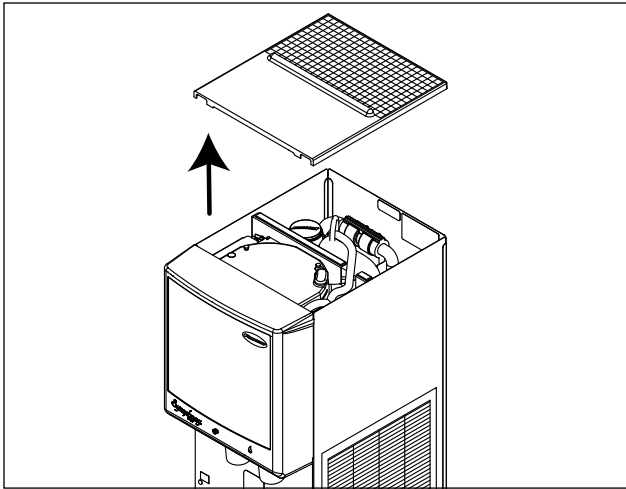

Top cover: Lift cover up and off Velcro strips.

Fig. 7

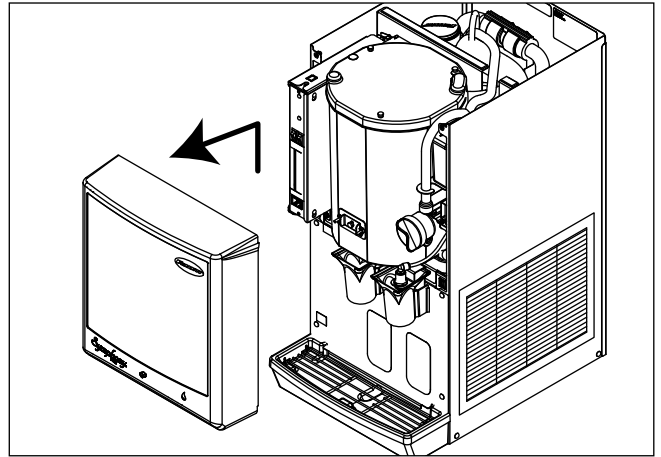

Front cover: Pull bottom of cover, then lift cover up and forward to unhook from keyhole slots.

Fig. 8

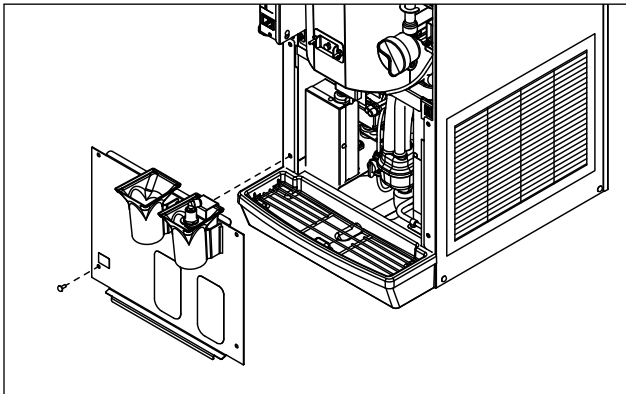

Splash panel: Remove 4 screws. Pull out bottom of panel to allow top to slide out from under hopper support lip.

1. Remove top and front panels of dispenser.
2. Remove electrical box cover.
3. Pull electrical box toward front of unit.

Fig. 9

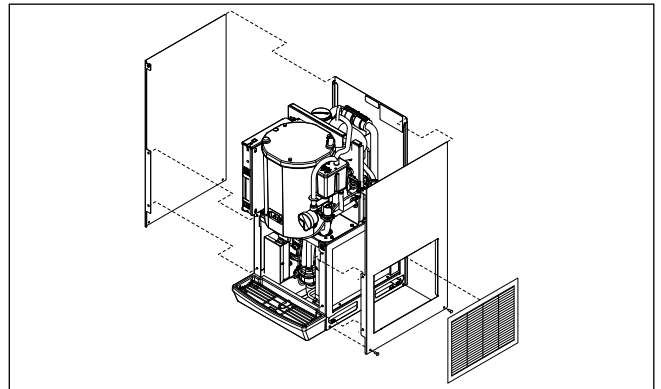

Side panels: Remove side louver panel by lifting up and pulling forward on panel. Remove screw located on lower rear side. Pull side panel toward front of unit and out of back panel.

Fig. 10

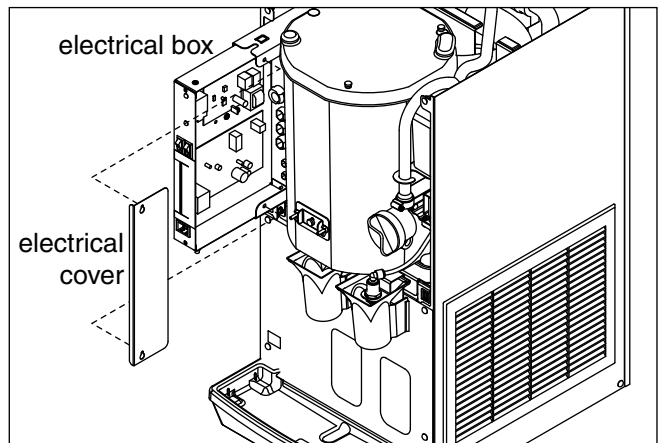

Electrical system



ATTENTION!

To prevent circuit breaker overload, wait 15 minutes before restarting this unit. This allows the compressor to equalize and the evaporator to thaw.

Normal control board operation

The PC board indicator lights provide all the information necessary to determine the machine's status. Green indicator lights generally represent "go" or normal operation; Yellow indicators represent normal off conditions; Red indicators generally represent alarm conditions, some of which will lock the machine off.

A flashing green light labeled POWER indicates power to the machine. All other normal operation status indicators are covered as follows:

Ice machine disposition	Operating conditions
Legend: ● ON ○ OFF ● ON or OFF ⊗ FLASHING	
1. Ice machine is making ice. CLEANER FULL ○ DRAIN CLOG ○ HI PRESS ○ HI AMPS ○ SERVICE ○ MAINT/CLEAN ○ LOW WATER ○ TIME DELAY ○ SLEEP CYCLE ○ MAKING ICE ● LOW BIN ● POWER ON ⊗	1. Normal running.
2. Ice machine is not making ice. CLEANER FULL ○ DRAIN CLOG ○ HI PRESS ○ HI AMPS ○ SERVICE ○ MAINT/CLEAN ○ LOW WATER ○ TIME DELAY ● SLEEP CYCLE ○ MAKING ICE ○ LOW BIN ● POWER ON ⊗	2. Normal time delay. When the bin fills with ice, the LOW BIN light goes out momentarily and the refrigeration and auger drive systems immediately shut down. (Note: The fan motor will continue to run for 10 minutes to cool condenser) The TIME DELAY light comes on, initiating the time delay period. When the time delay expires, the machine will restart provided that the LOW BIN light is on.

Control board DIP switch settings

OFF POSITION ON POSITION

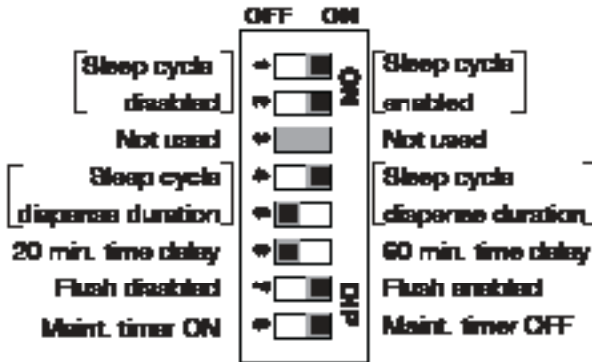

Sleep cycle dispense duration

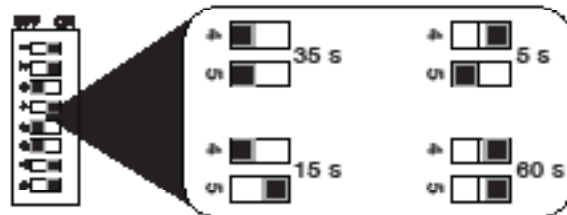

Relay/triac output indication

Each relay on the board has an indicator light associated with its output. For example, when the relay for the water feed solenoid is energized, the adjacent indicator light glows green.

Flushing logic

Off cycle: At the completion of off-cycle time delay, the machine checks for a cumulative one (1) hour of ice making time since the last off-cycle flush. If the cumulative ice making time exceeds one (1) hour, the machine will open the drain valve for 60 seconds to drain the evaporator in its entirety. It will then refill with water, flush again and refill, and begin making ice. If the ice making time is less than 1 hour, the machine will start and begin making ice without draining the evaporator.

Error faults

The Maestro Plus PC board monitors various operating parameters including high pressure, auger gearmotor amperage limits, clogged drain, and low water alarm conditions. There are two types of errors namely "hard" or "soft". A hard error is one that shuts the machine off and will not allow restart until the reset button is pressed. Even cycling power will not reset a hard error. A soft error can either be automatically reset should the condition rectify, or if power is cycled. Should an error occur, consult the troubleshooting guide in this manual or a Follett service technician.

Soft errors:

Note: For all soft errors, the ice machine will remain off for 1 hour.

LO WATER: During operation, the water level cycles between the normal low and normal high sensors. Should the water be shut off to a running machine, a soft error will occur. The error sequence is as follows: During operation, the water level falls to the normal low sensor, and when it does the water feed solenoid is energized. If water is not detected at the normal low sensor within 10 seconds, a soft error will occur. The machine will shut down and TIME DELAY and LOW WATER LEDs will be lit. After time delay, the solenoid will energize and remain energized until the water level is sufficient for restart.

HI PRESSURE: Should the refrigeration pressure rise above 425 psi, the machine will shut down and the TIME DELAY and HIGH PRESSURE will be illuminated. After the time delay, and if the pressure has fallen back below the reset point of 295 psi, the machine will restart and the TIME DELAY and HIGH PRESSURE will clear.

HI AMPS: The PC board monitors the amperage of the auger motor. Should the gear motor experience current draw above the allowable 1.8A limit or no current draw (0A), the machine will shut down and the TIME DELAY and HI AMP will be illuminated. After the time delay the machine will restart and the TIME DELAY and HI AMP will clear.

Hard error:

HI AMPS: If a second hi-amp error occurs within 1 hour of the initial hi-amp error, the ice machine will shut off and the reset on the board must be pressed to clear the error. If a second hi-amp has occurred, the HI AMP LED only will be illuminated.

DRAIN CLOG: The drain clog sensor, located in the evaporator drain pan will detect the presence of water just below the top edge of the pan. If water does not properly flow out of the internal or external drain lines it will backup into the drain pan (especially during a self-flushing purge cycle). Pressing the reset button will restart the ice machine.

Wiring diagram - 230 V 50 Hz

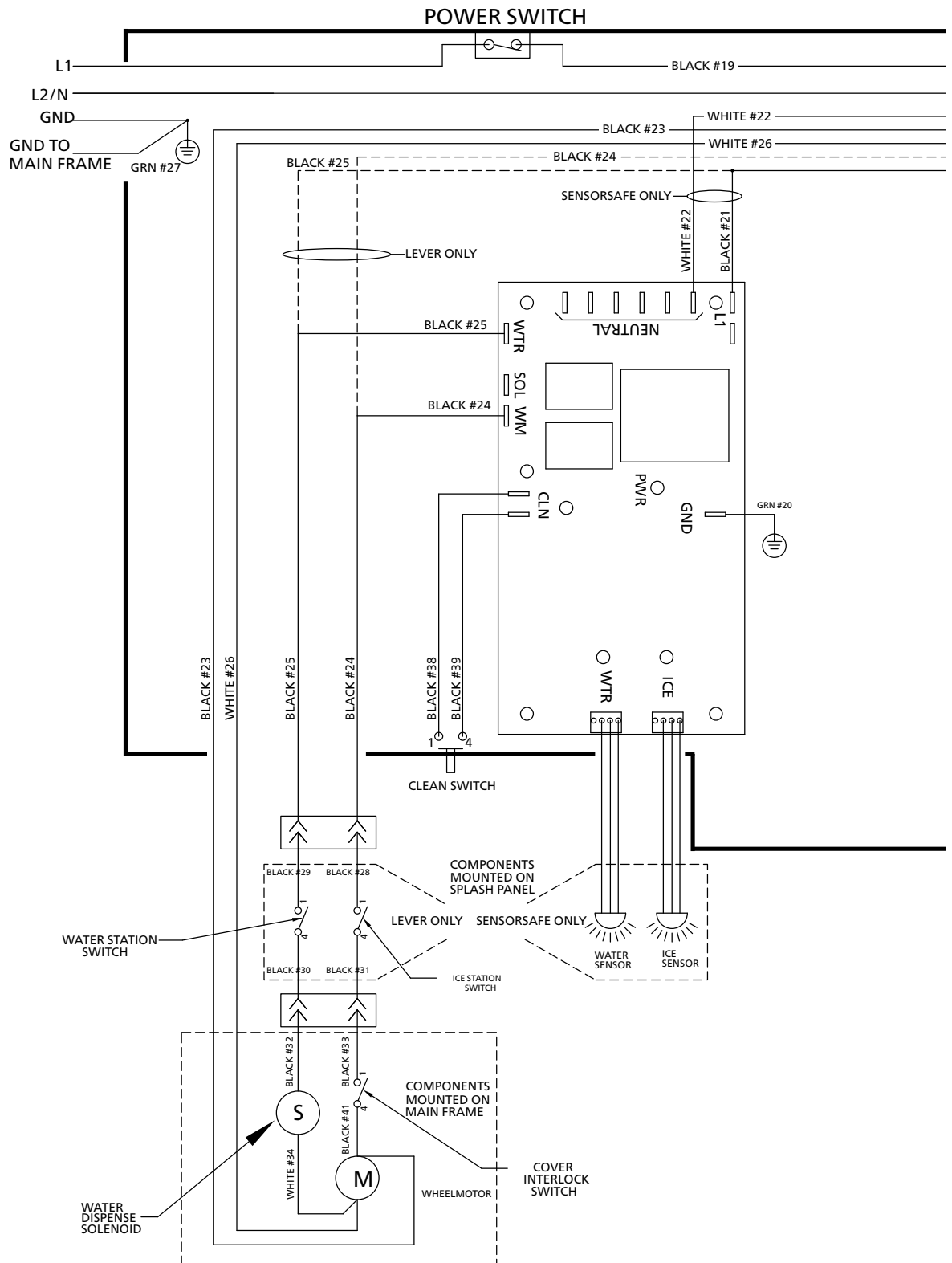

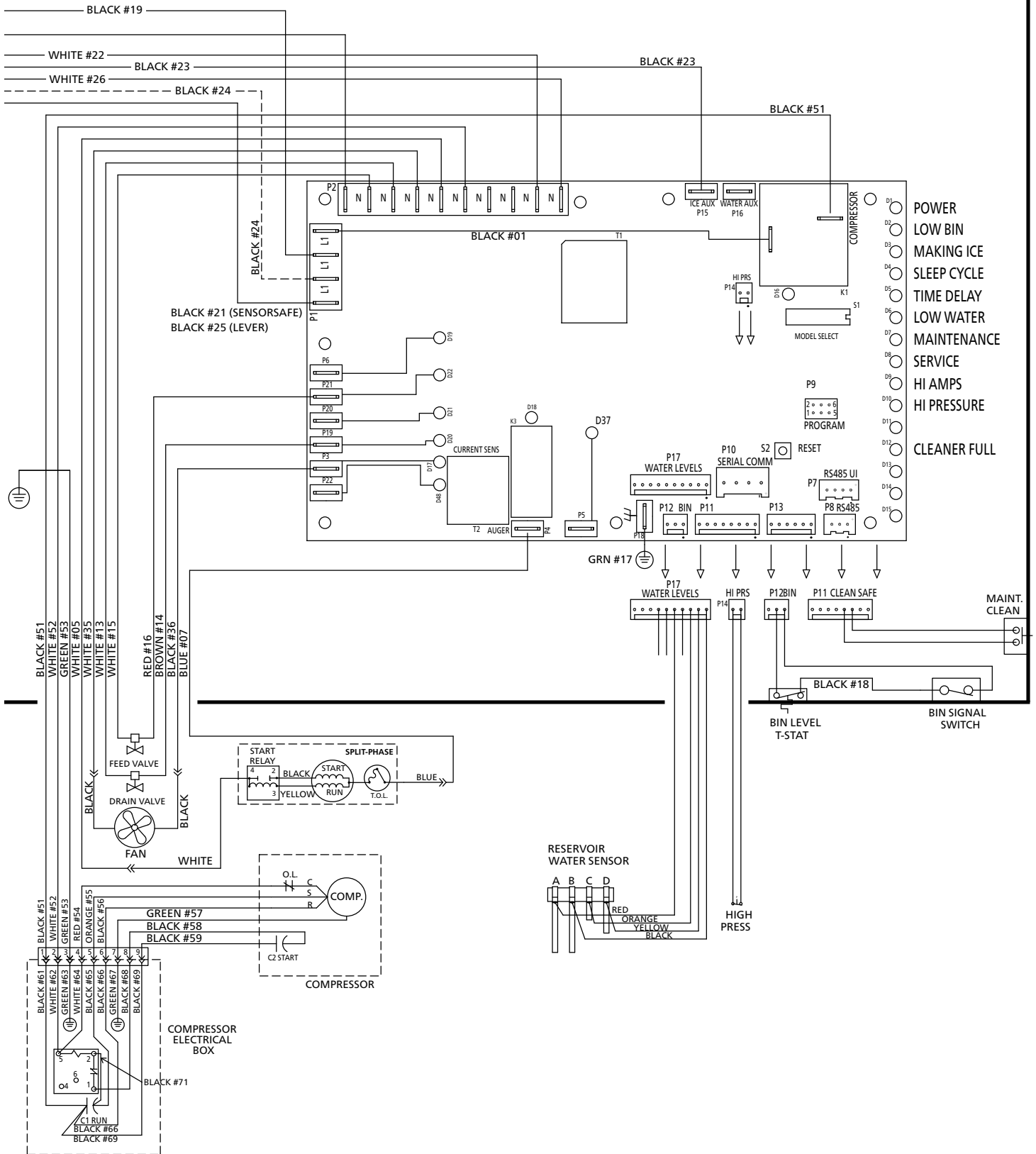

Wiring diagram - 220 V 60 Hz

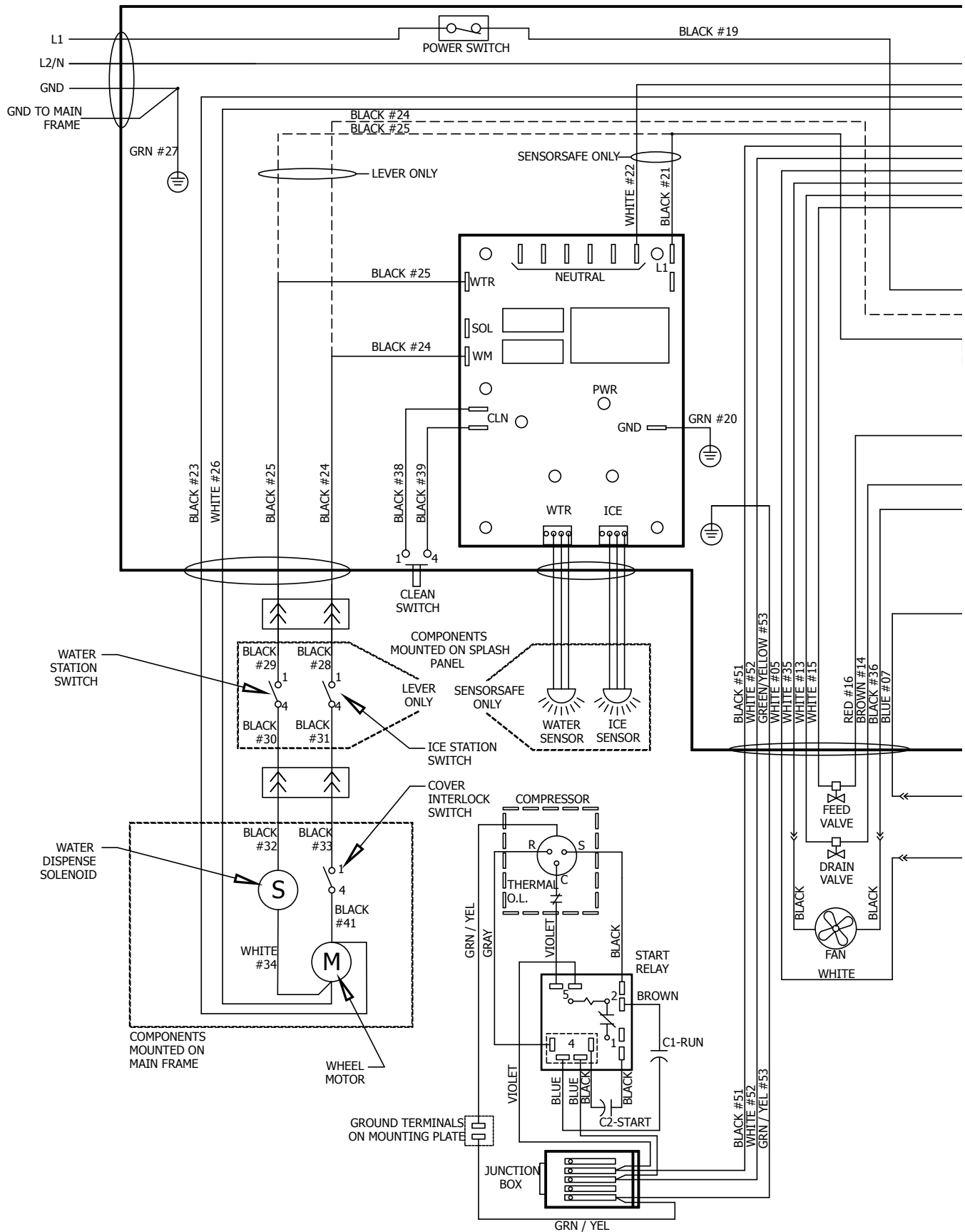

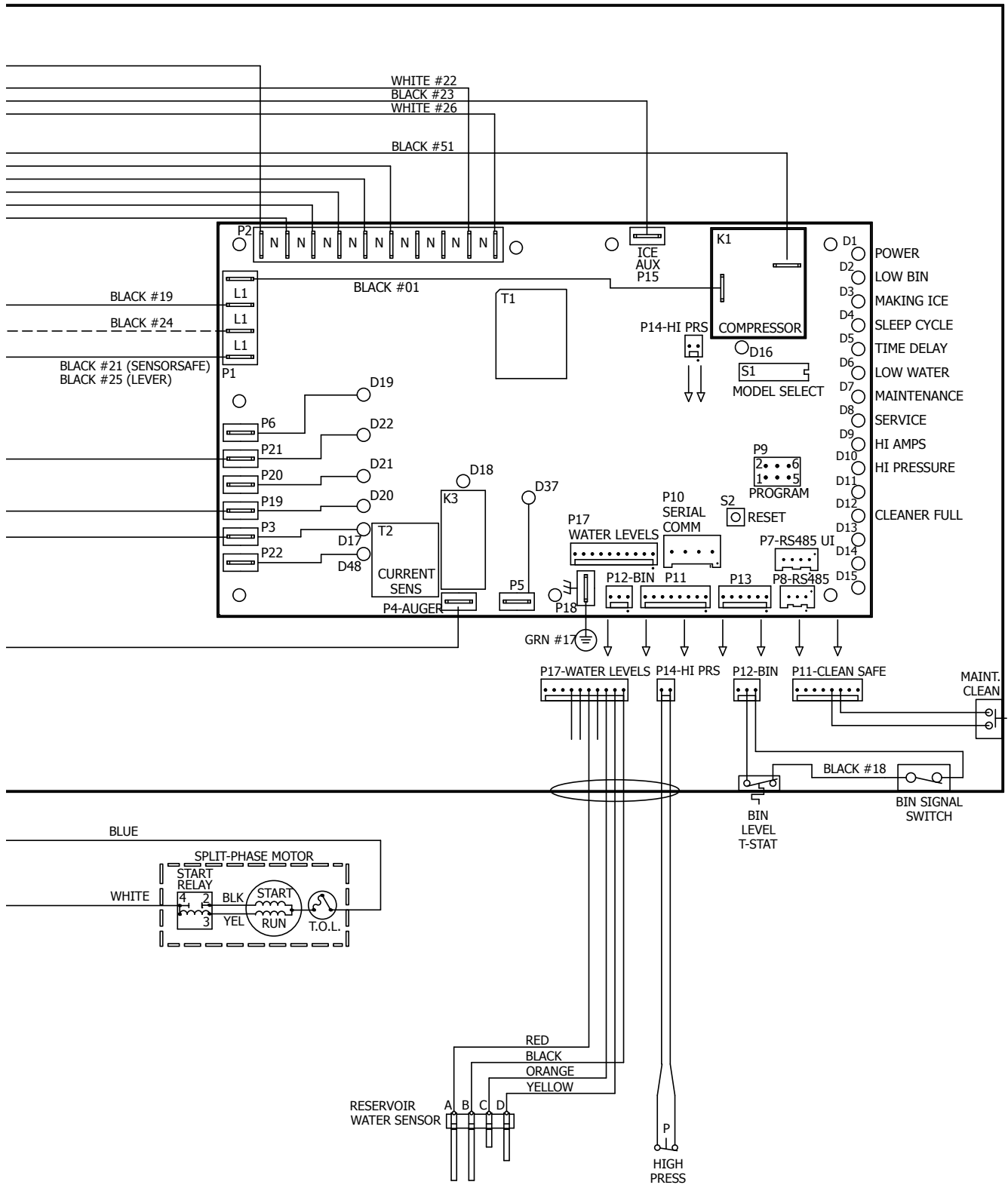

Wiring diagram - Lever only

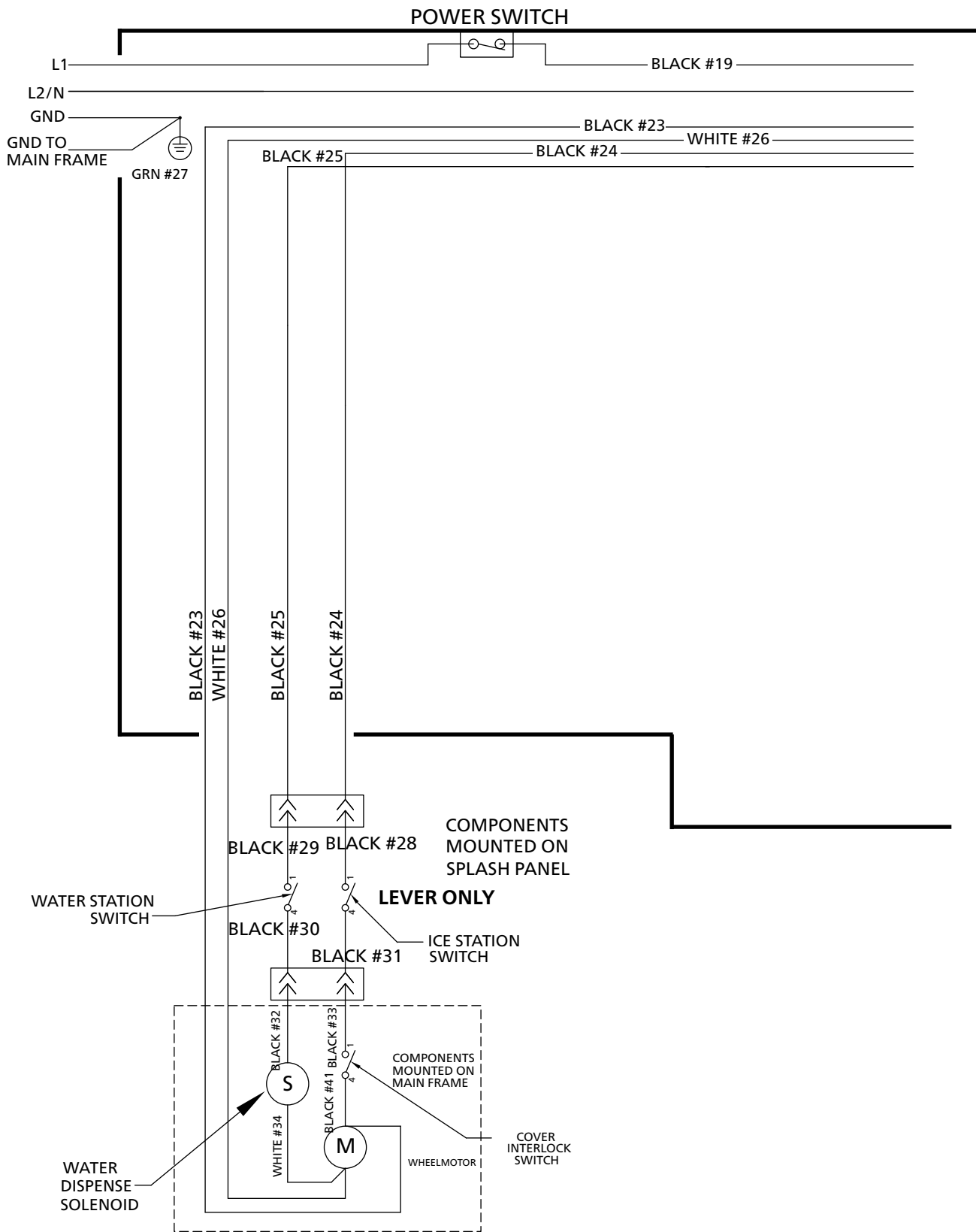

Wiring diagram - SensorSAFE only

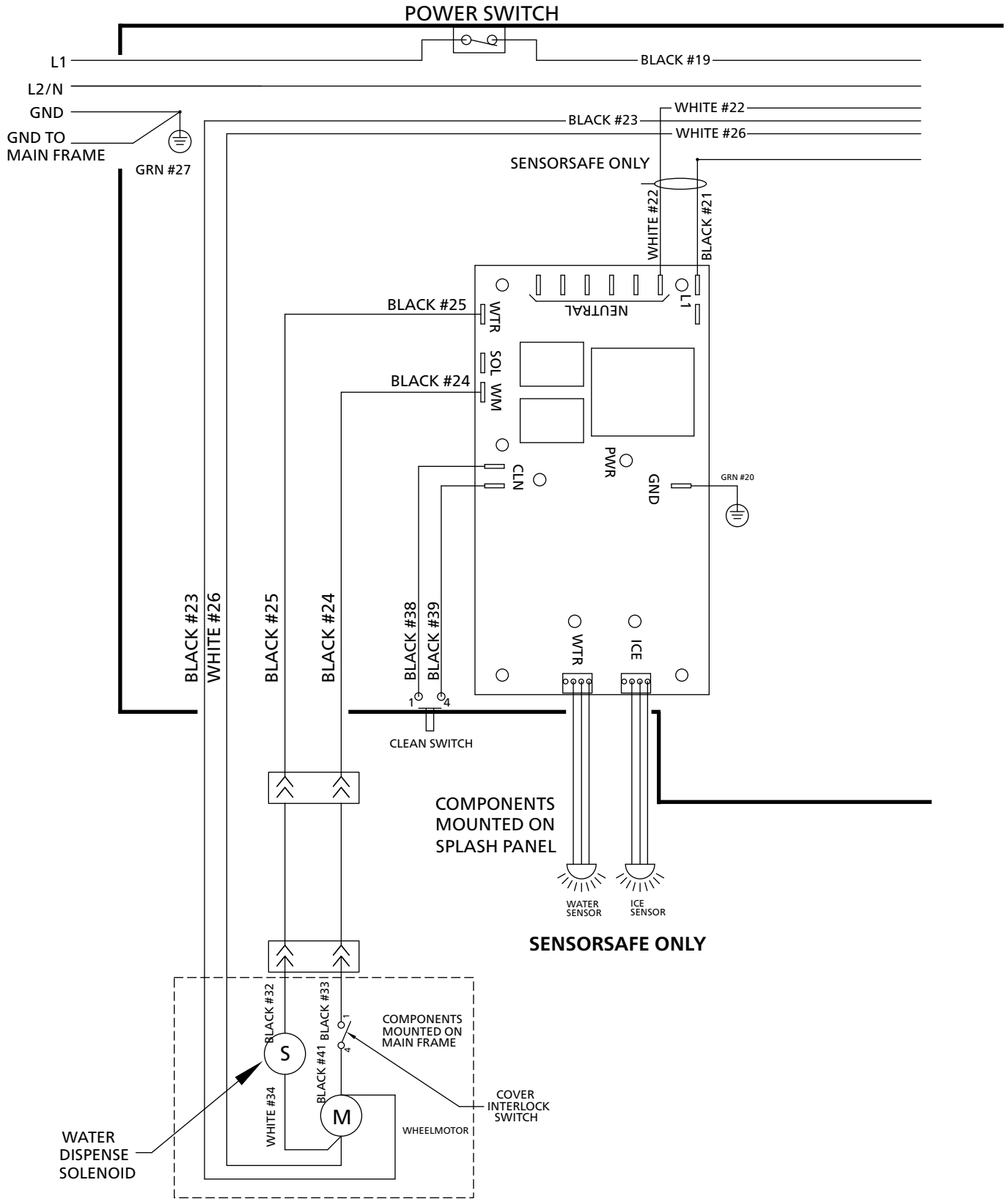

Ice machine operational and diagnostic sequences

The wiring diagrams that follow illustrate the circuitry of Follett ice machines used with 12 series ice dispensers. Both normal operation (stages 1–8) and non-normal diagnostic sequences showing torque-out for use in troubleshooting are shown.

Circuitry notes

- Bin signal is contact closure only - **DO NOT SUPPLY POWER.**

Normal operation – Stage 1

Power is supplied to L1 of the control board, the **POWER** LED light begins flashing. The ice level bin thermostat is closed and calling for ice, supplying contact closure to the control board. The **LOW BIN** LED will be on. The control board will now go through the start-up sequence. The board checks the water sensors (located in the reservoir) for continuity between the common probe (B) and the high probe (C). If continuity is not sensed, the water fill valve (P21) is energized.

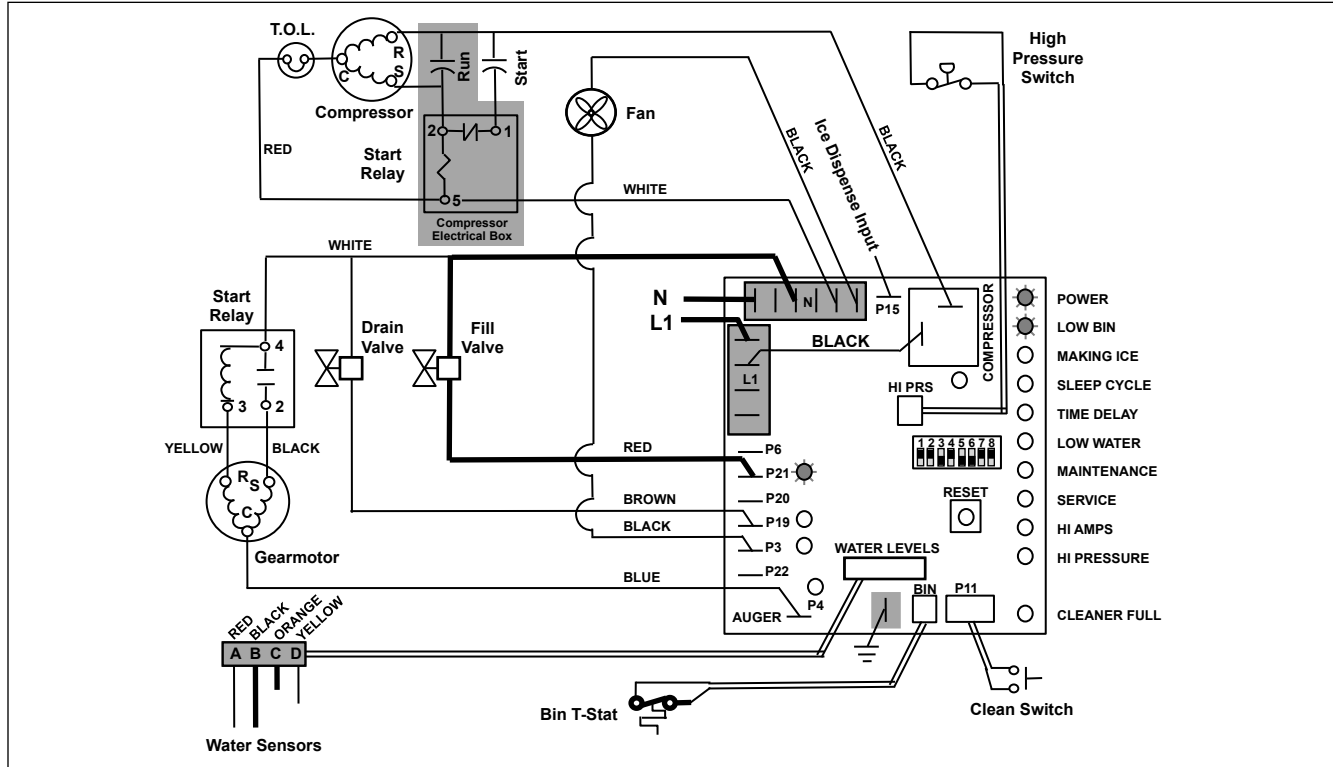

Normal operation – Stage 1 - 220 V 60 Hz

The 220 V 60 Hz is identical to the 230 V 50 Hz EXCEPT that the compressor output and neutral are reversed, as shown in the diagram below. The remaining Stages show only the 230 V 50 Hz applications.

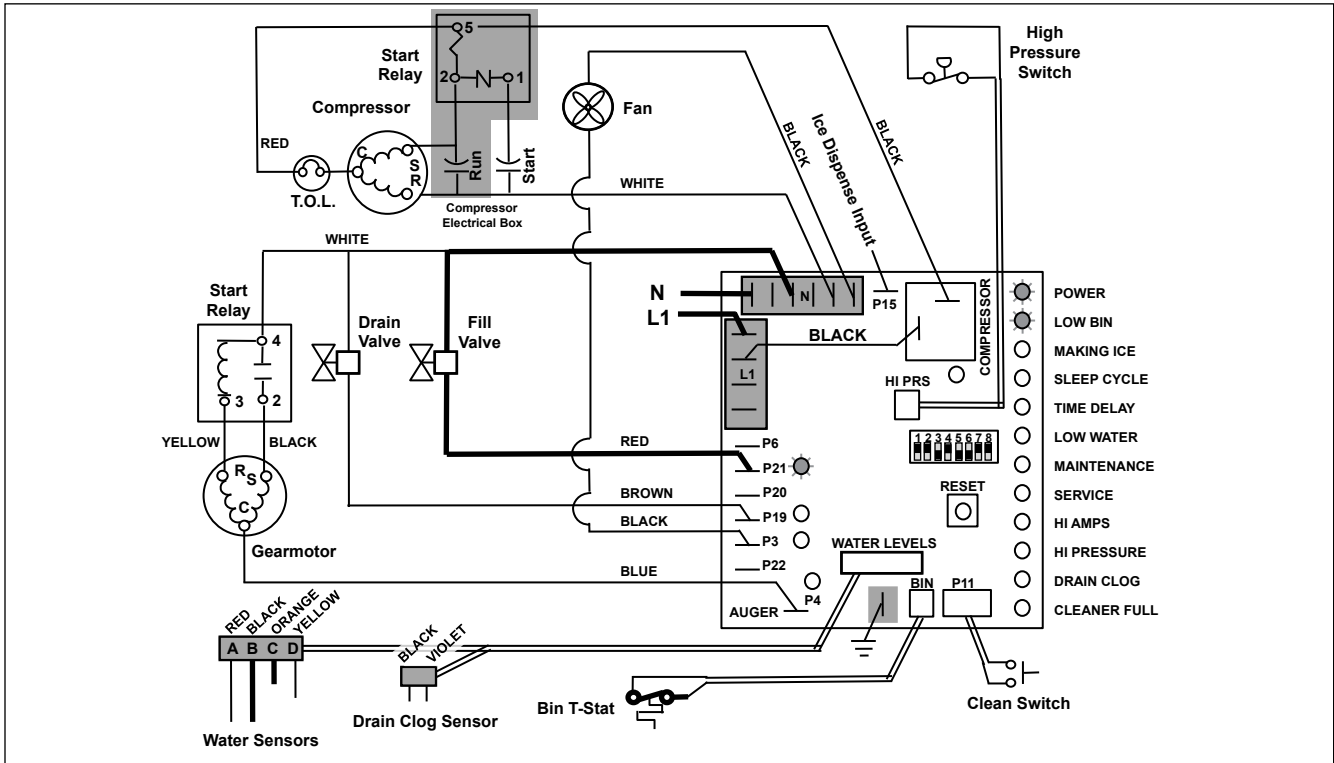

Normal operation – Stage 2

When continuity is seen between B and C, the water valve de-energizes, the AUGER output (P4) comes on along with the **MAKING ICE** LED. The auger gearmotor's start windings are energized through a current style start relay that is pulled in by the initial high current draw of the gearmotor.

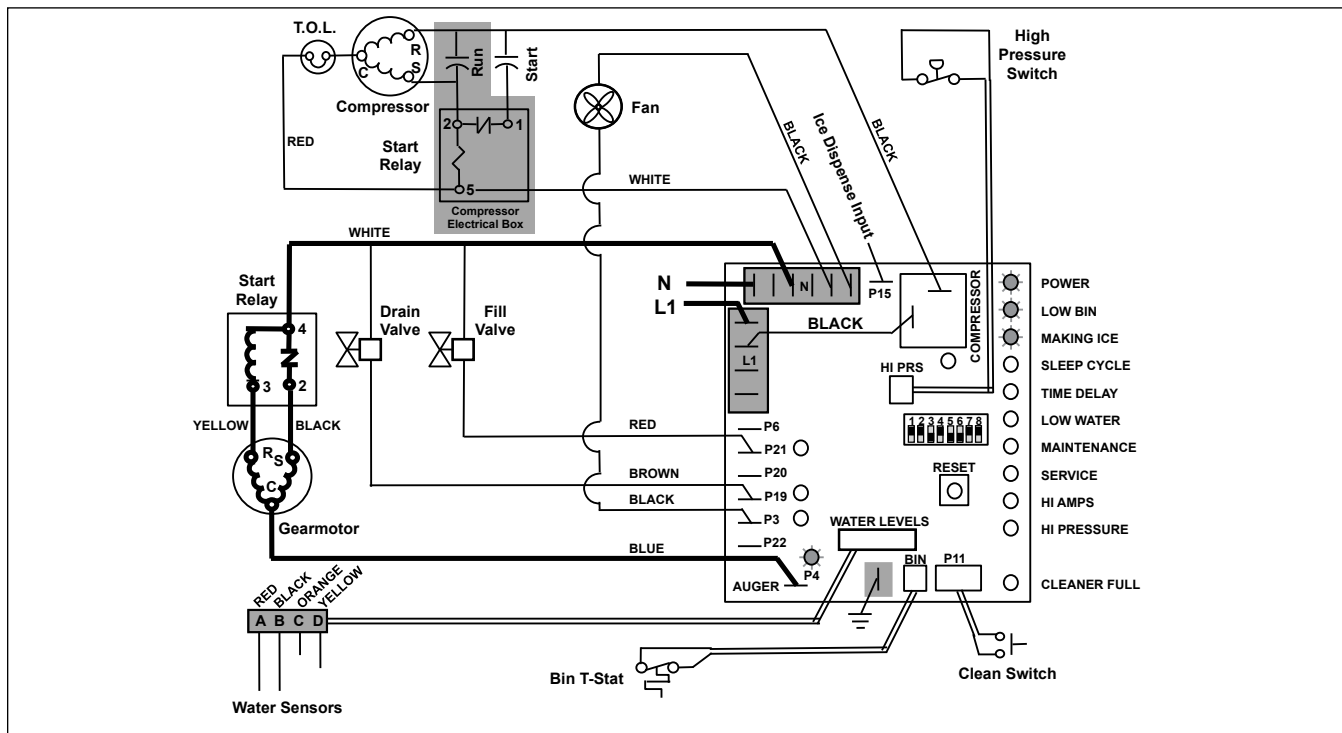

Normal operation – Stage 3

After the initial high current draw drops off, the gearmotor start relay contacts open, dropping out the start winding. The condenser fan output (P3) comes on 0.5 seconds later.

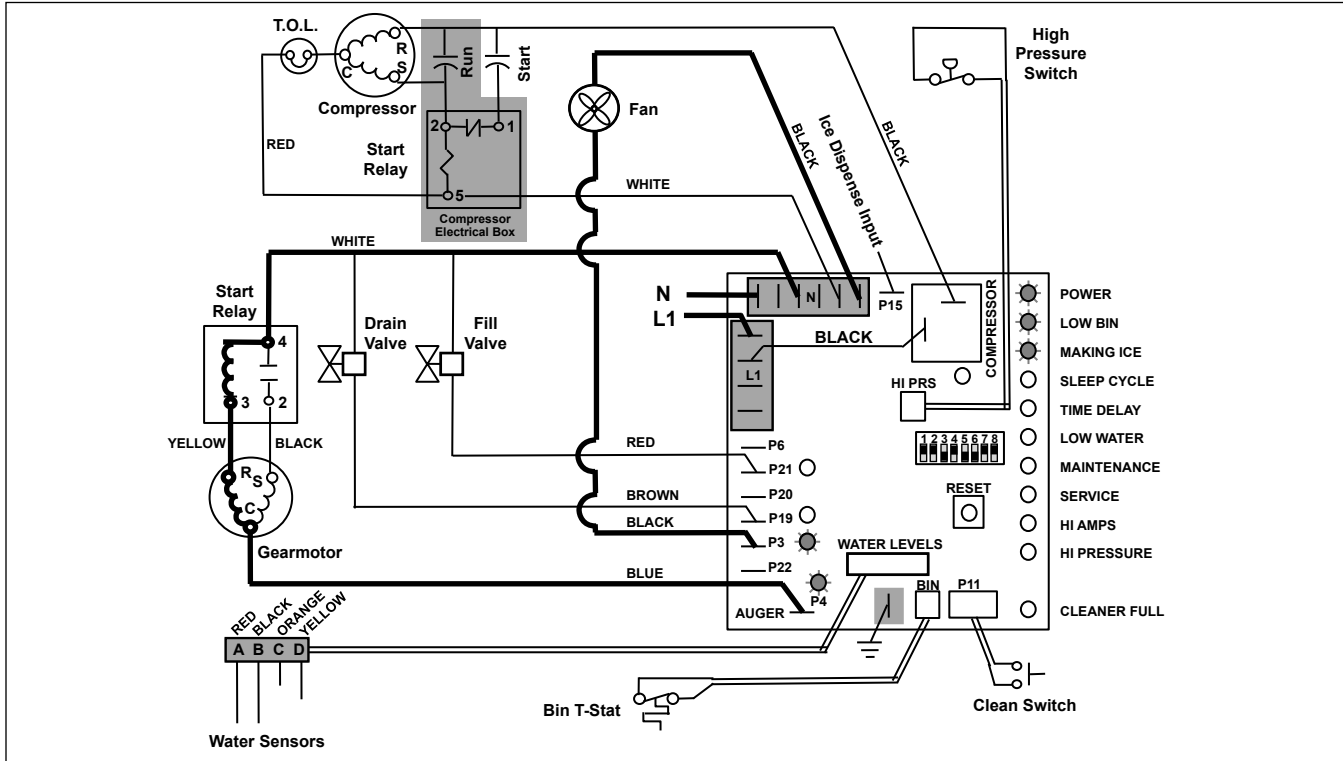

Normal operation – Stage 4

One second (1 s) after the fan comes on, the **COMPRESSOR** output comes on. The compressor circuit uses both run and start capacitors along with a potential start relay. The start capacitor is energized through the normally closed contacts of the start relay.

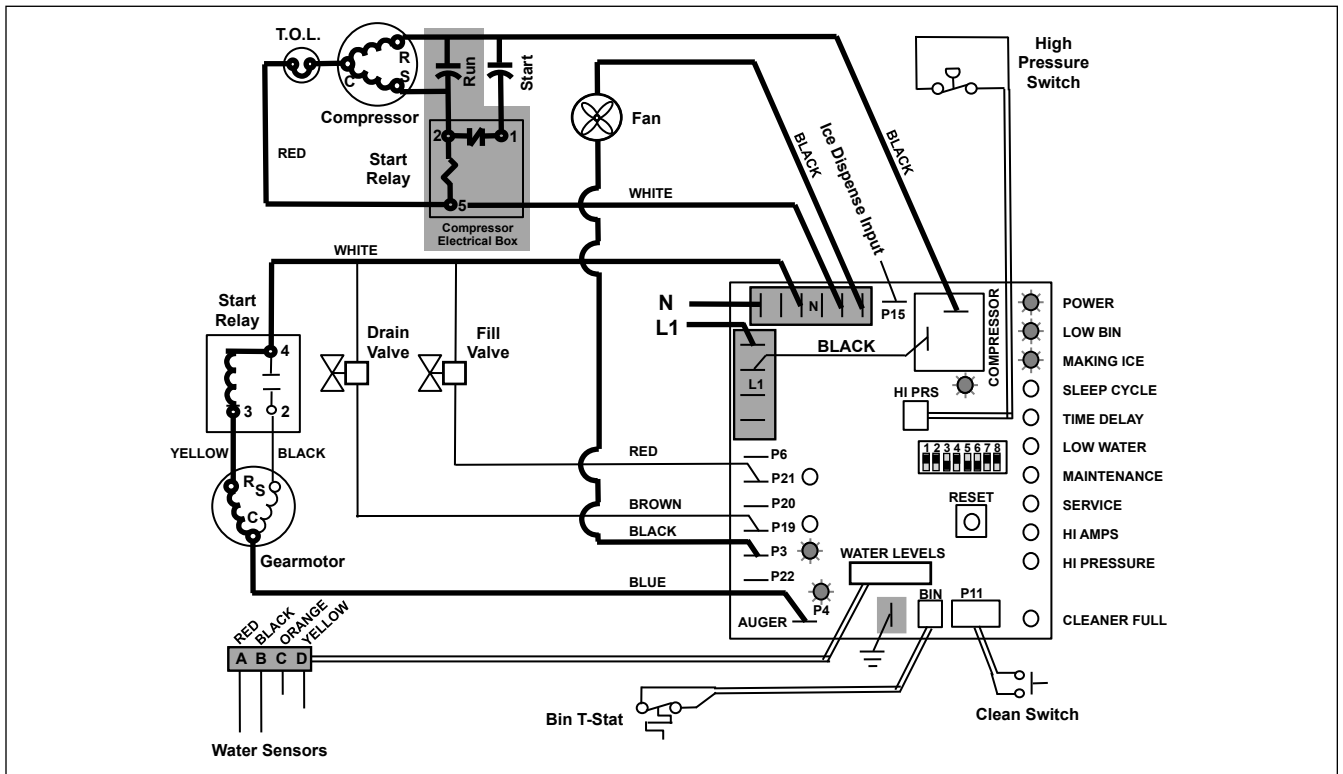

Normal operation – Stage 5

As the compressor comes up to normal running speed, its start winding generates a voltage potential across the relay's coil. This energizes the coil to open the contact and drop out the start capacitor.

The ice machine is now in a normal ice making mode. The ice machine will produce ice until the bin level control in the ice dispenser is satisfied.

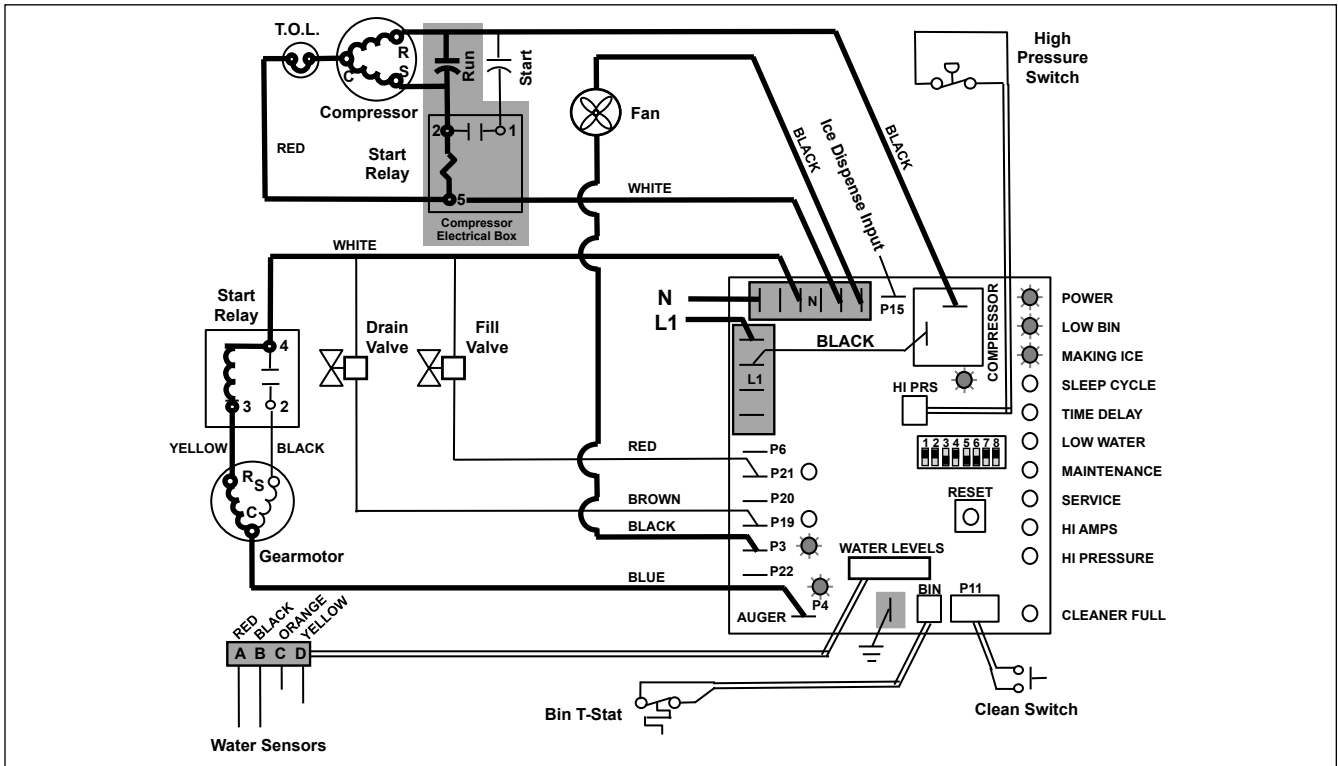

Normal operation – Stage 6

Once the bin thermostat control opens, the **LOW BIN** LED goes out. After a 10 second delay the compressor output turns off, the **MAKING ICE** LED goes out and the **TIME DELAY** LED comes on.

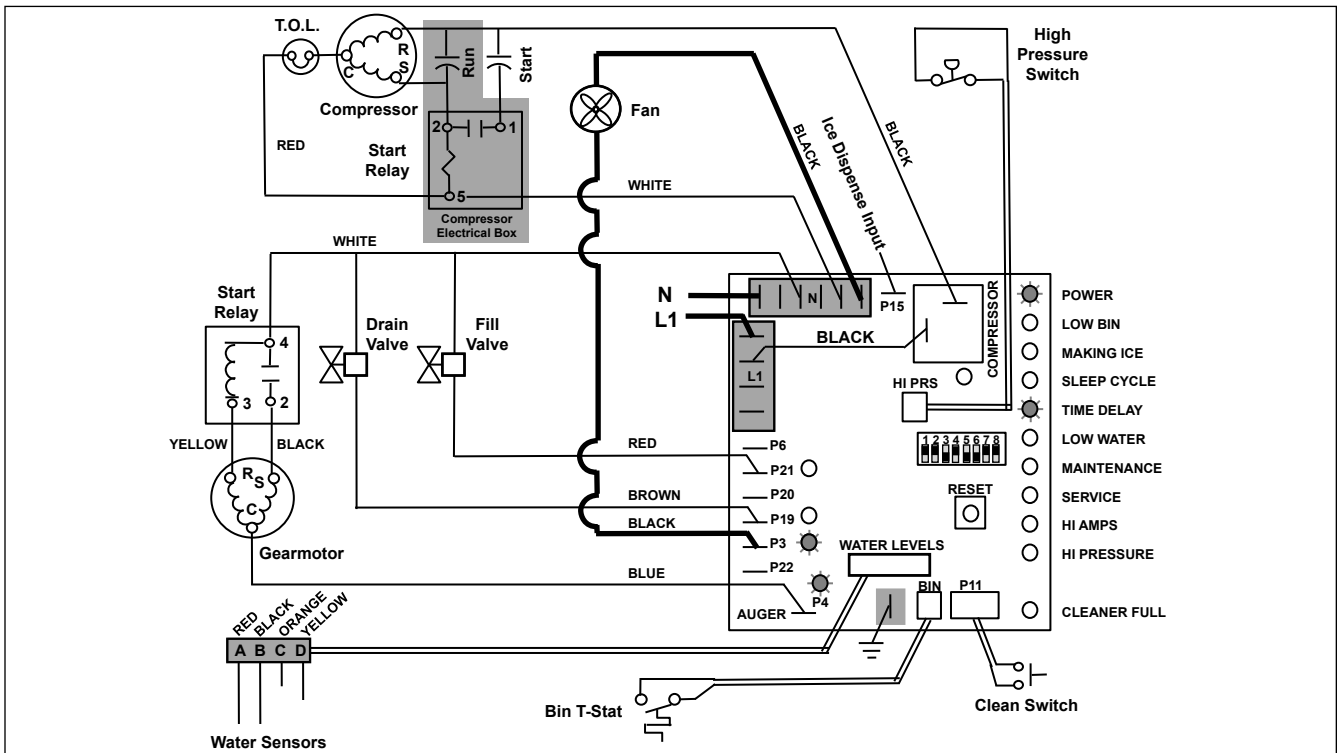

Normal operation – Stage 7

The fan motor continues for 10 minutes before shutting off. The **TIME DELAY** LED remains on for 20 minutes. The ice machine will not start while the **TIME DELAY** LED is on. To restart the ice machine for troubleshooting purposes, depress the reset button to clear the control board.

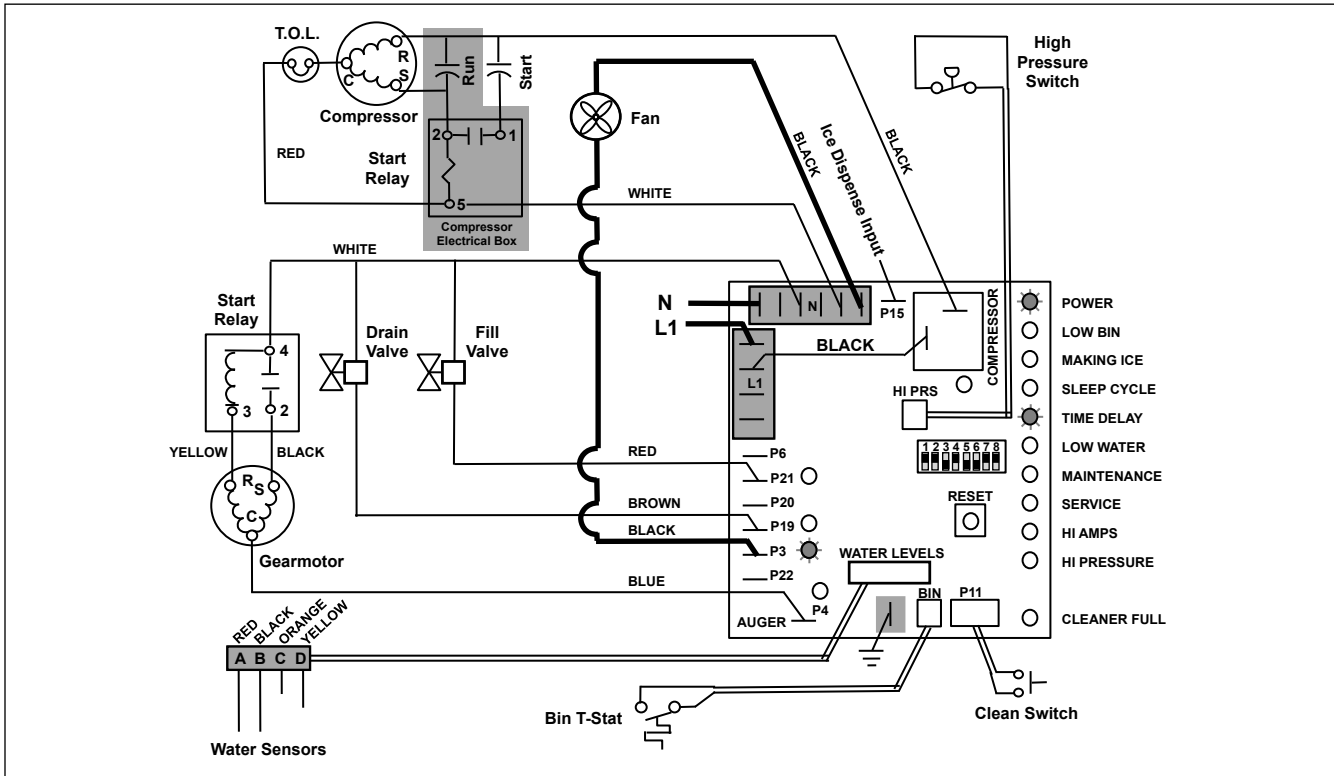

Normal operation – Stage 8

When the dwell time of 20 minutes has expired, the **TIME DELAY** LED goes off. If 5 seconds of ice has been dispensed and the **SLEEP CYCLE** LED is off, the ice machine will go through the normal start-up sequence when the bin level control signals the control board for ice.

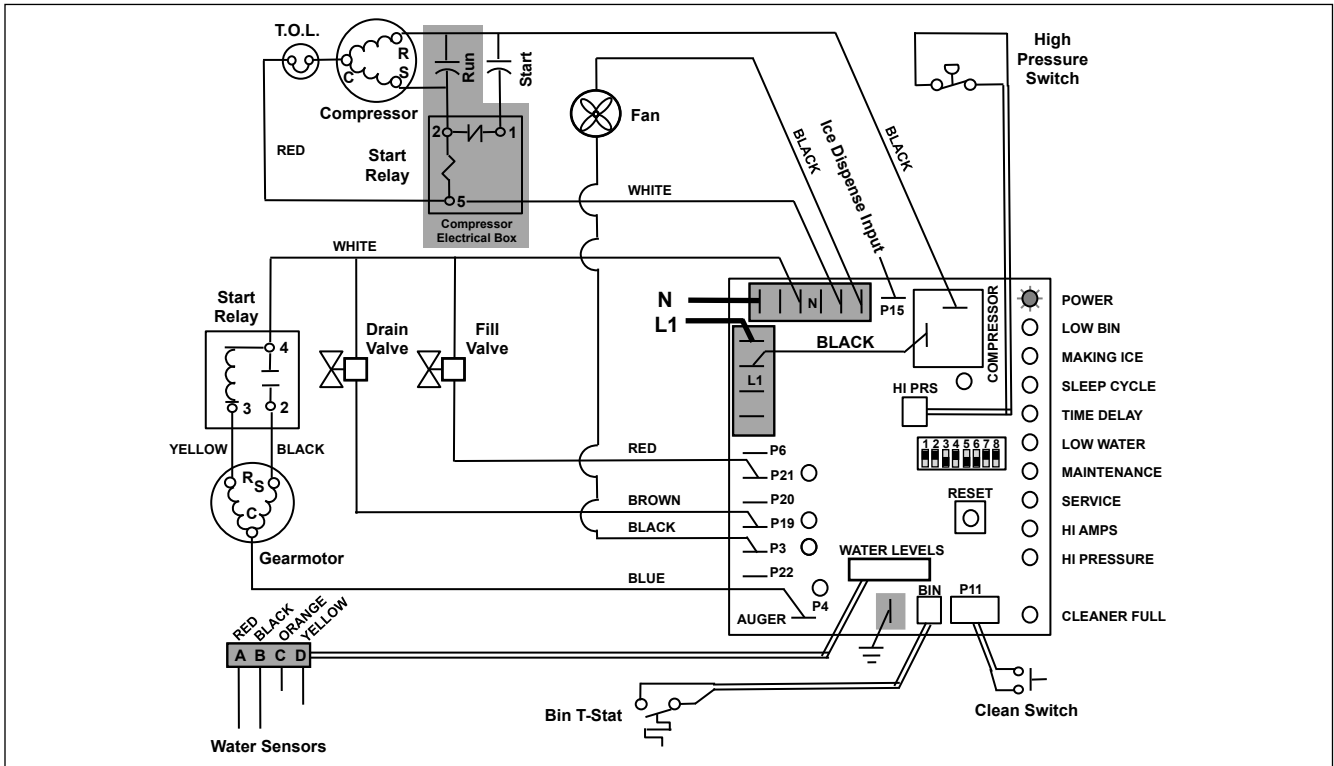

Quiet Night™/Sleep cycle

The board monitors ice dispensing through a line voltage input to P15. If the ice dispense has not be initiated for more than 5 seconds during the 20 minute time delay, the **SLEEP CYCLE** LED comes on. The machine will stay off for 12 hours unless 5 seconds of dispensing is seen. After 12 hours, the **SLEEP CYCLE** LED goes out and the ice making will resume if the bin thermostat is closed. The sleep cycle dispense duration is adjustable using the DIP switches on the control board.

Self-flushing

At the completion of the 20 minute time delay, the machine checks for a cumulative one hour of ice making time since the last off-cycle flush. If the cumulative ice making time exceeds one hour, the machine will energize the drain valve P19 for 60 seconds to drain the evaporator. It will then refill with water, flush again, refill and begin making ice if the **LOW BIN** LED is on. If the ice making time is less than 1 hour, the machine will start and begin making ice without draining the evaporator.

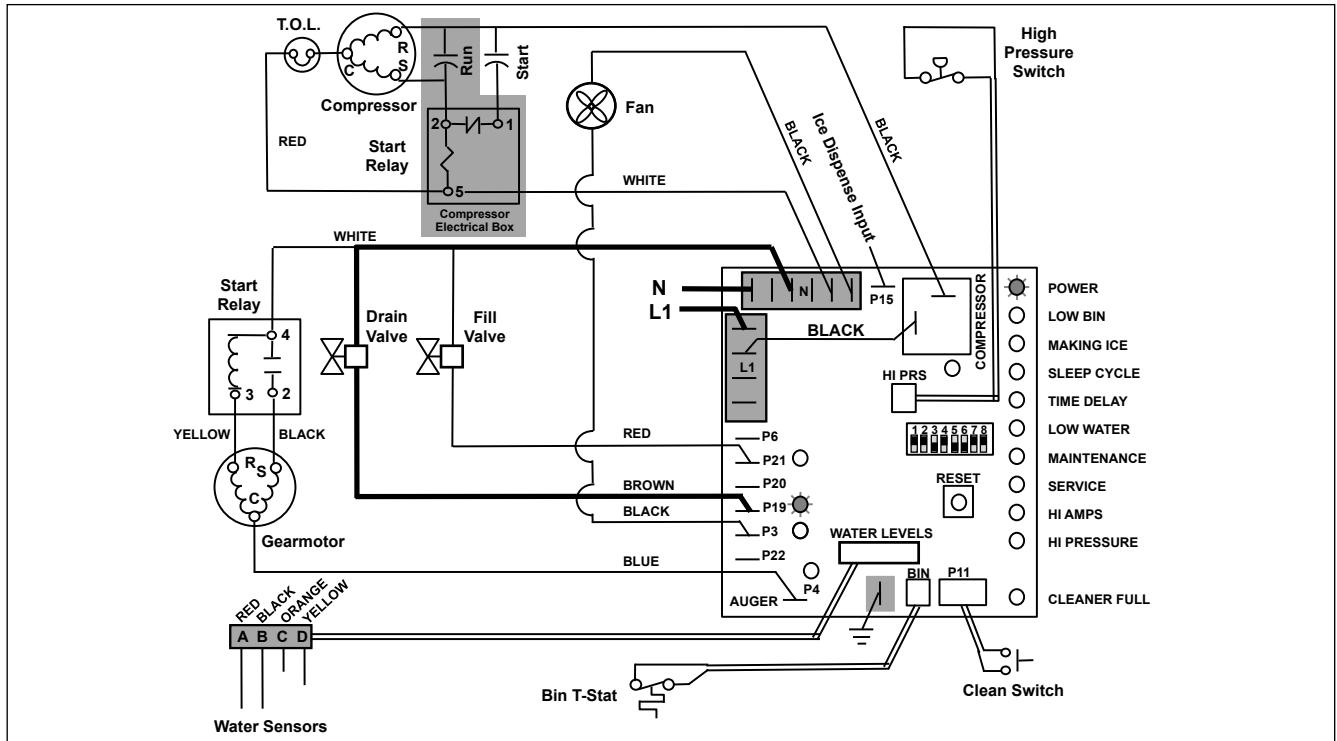

Diagnostic stages

High gearmotor amps – Stage 1

The **HI AMPS** error and **TIME DELAY** LEDs are on indicating that the control board has sensed an over-torque condition at the P4 terminal (more than 3A from the gearmotor) or no current draw (0A) and shut the ice machine down (strike one). The **HI AMPS** and **TIME DELAY** LEDs will remain on for 60 minutes after an over-torque condition has occurred. The ice machine will remain off as long as these two LEDs are on. After the 60 minute time delay, these LED lights turn off, and the control board will try to go through a normal start-up sequence.

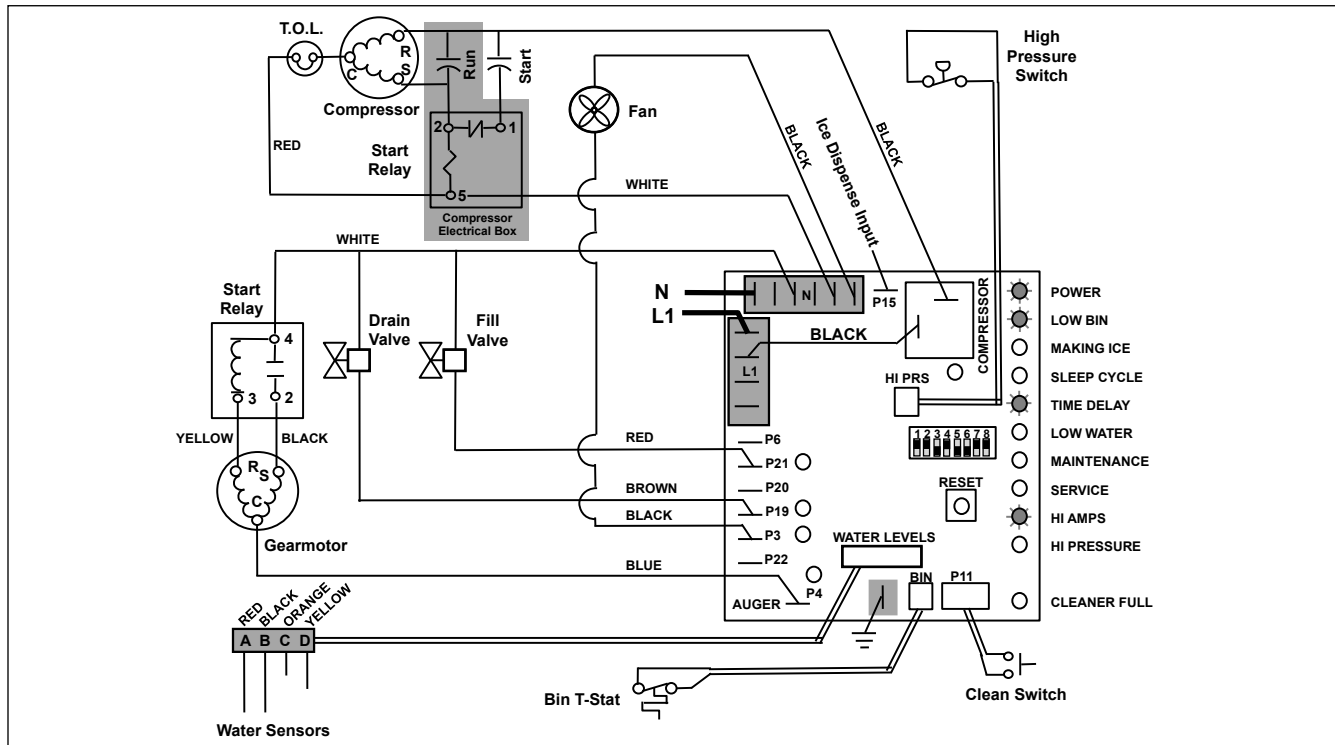

High gearmotor amps – Stage 2

If the restart is successful the board will continue to monitor the current draw on P4 for 60 minutes looking for a second high amps (above 1.8A) or no current draw (0A) occurrence. If the ice machine runs without problems for 60 minutes and no additional torque errors occur, the ice machine will continue normal operation.

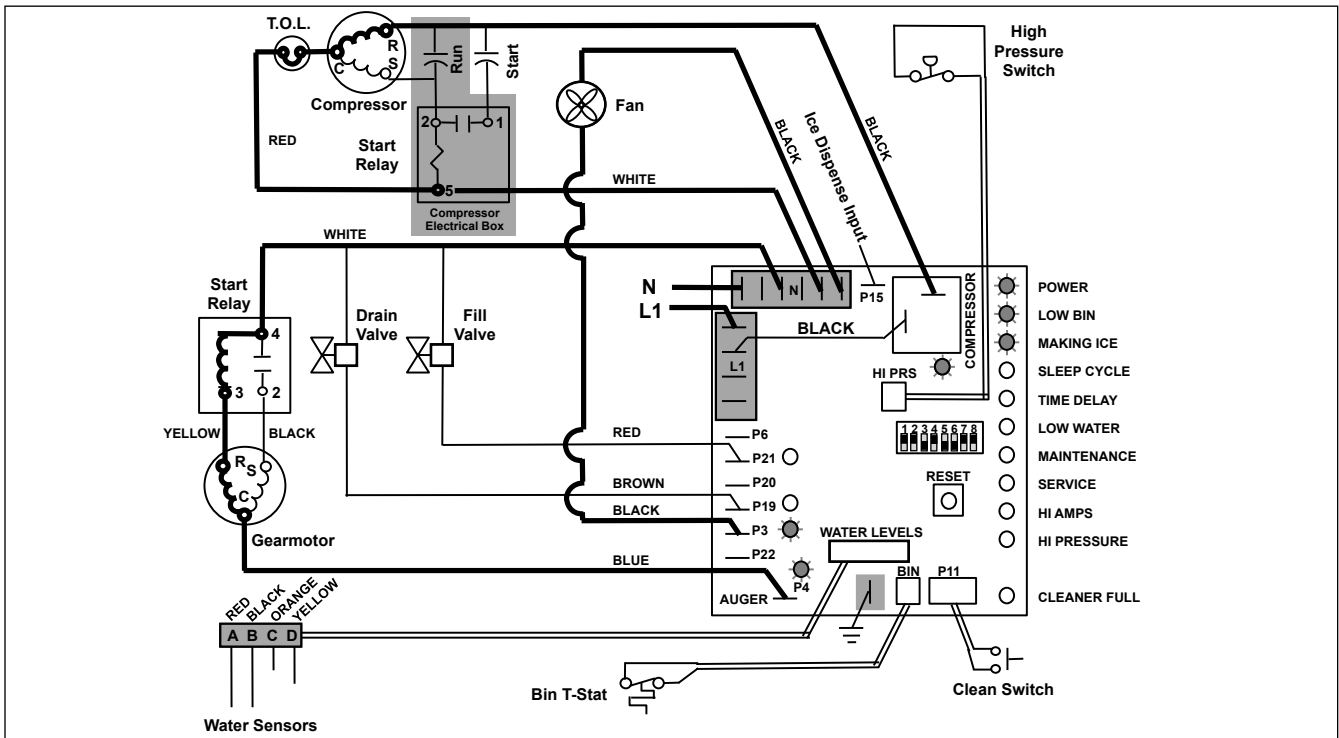

High gearmotor amps – Stage 3

If a second occurrence happens during the 60 minute monitoring period, the **HI AMPS** LED will come on again and shut the machine down (strike two). The **HI AMPS** LED (without the **TIME DELAY** LED) will indicate to the technician that two consecutive over-torque situations have occurred. The ice machine is shut down at this time and locked out. It will not restart unless the manual reset button is depressed while power is on.

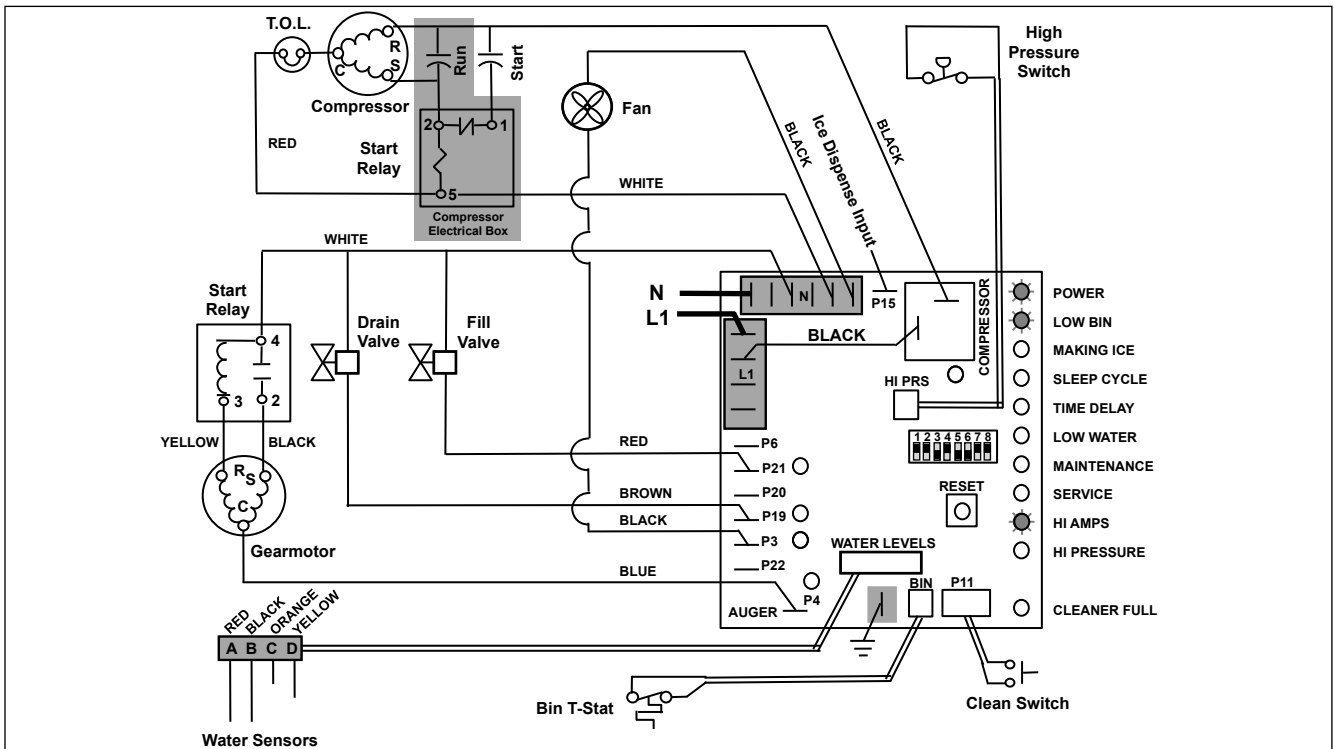

Loss of water

During operation, the water level cycles between the normal low (D) and normal high (C) water probes - the fill valve (P21) cycling on and off. If continuity is not detected between the common probe (B) and normal low (D) within 10 seconds, the **LOW WATER** and **TIME DELAY** LEDs will come on and the machine will shut down for the one hour time delay period. After the time delay, the fill valve will re-energize and wait for continuity between the common probe and normal high before restarting. **LOW WATER** LED will remain ON until the water level is satisfied.

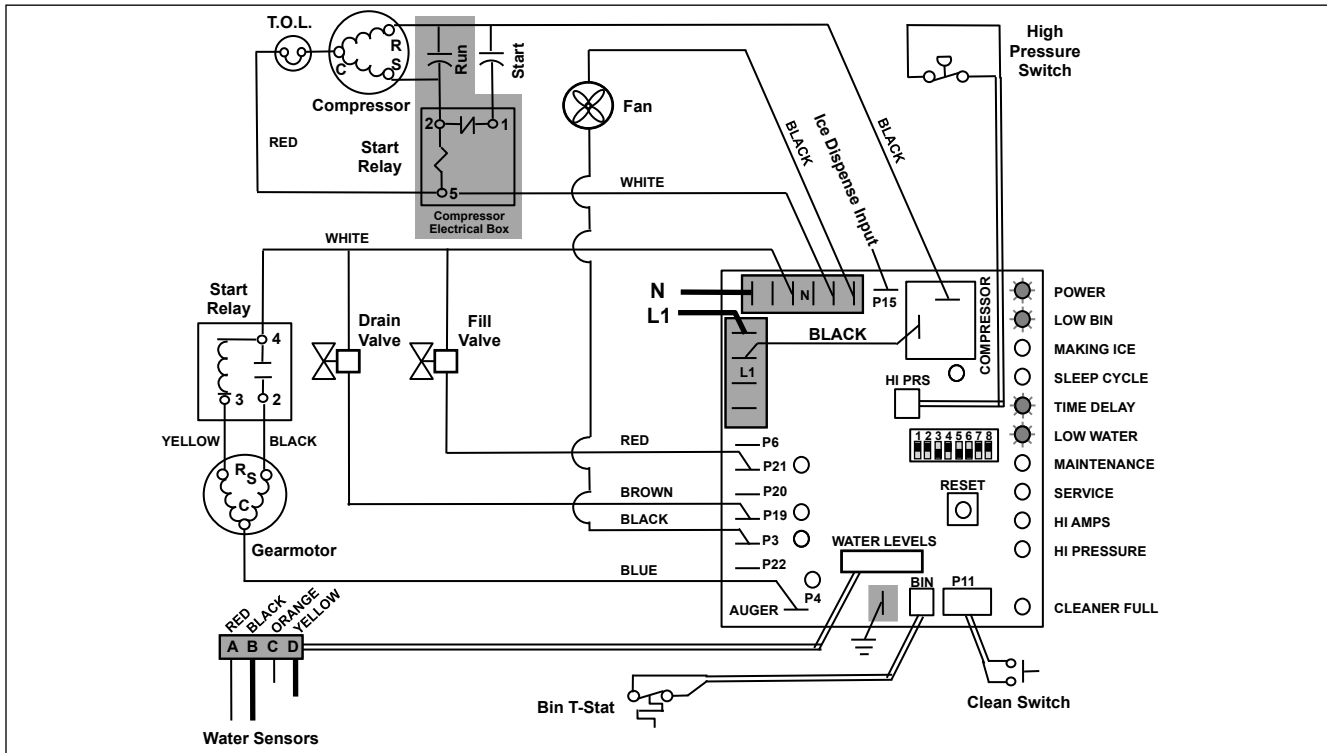

High refrigerant pressure

Should the refrigeration pressure rise above 425 psi, the high pressure switch contacts will open. The board sees the open circuit and the **HIGH PRESSURE** and **TIME DELAY** LEDs will come on, the machine shuts down. After the one hour time delay, the machine will attempt to restart. If the pressure has fallen below the reset point of 295 psi and the board see the contacts closed, the machine will resume normal operation. If the contacts are still open after the restart, the board will again go into **HIGH PRESSURE** and **TIME DELAY**, cycling until contact closure is seen.

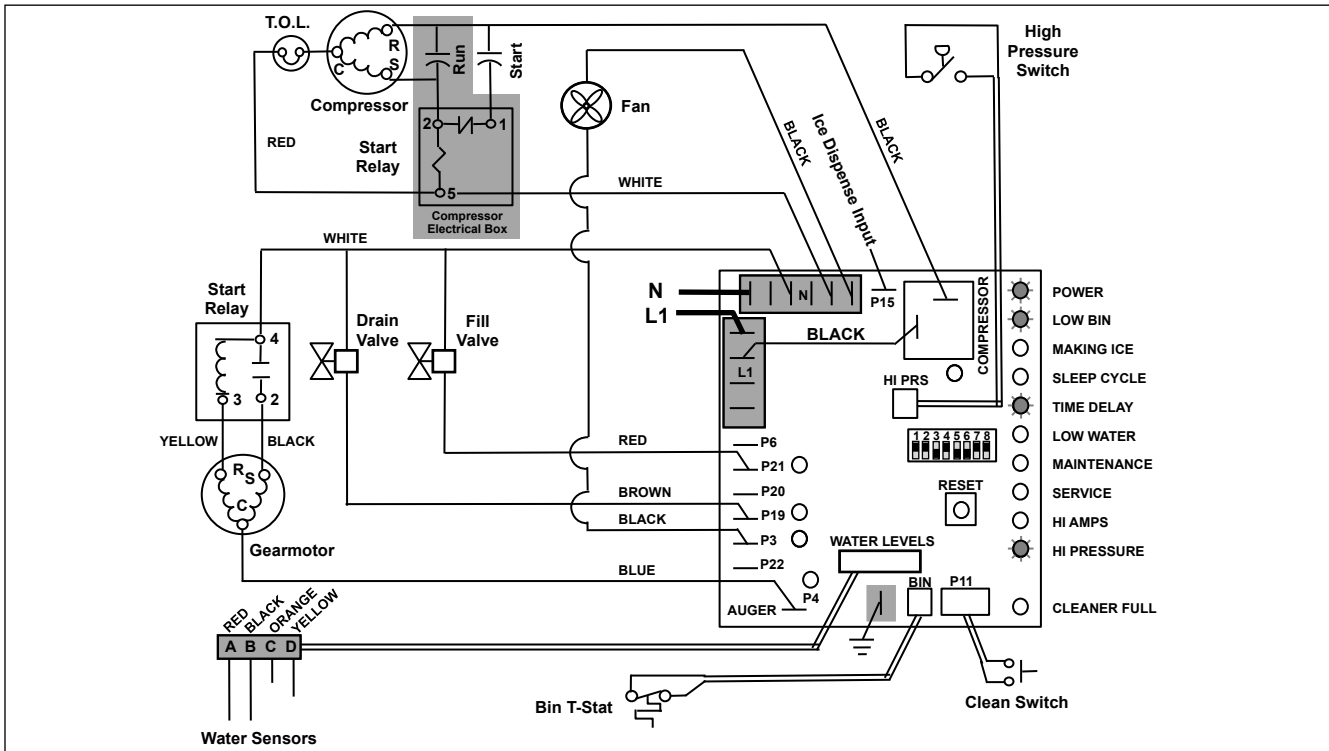

Refrigeration cycle

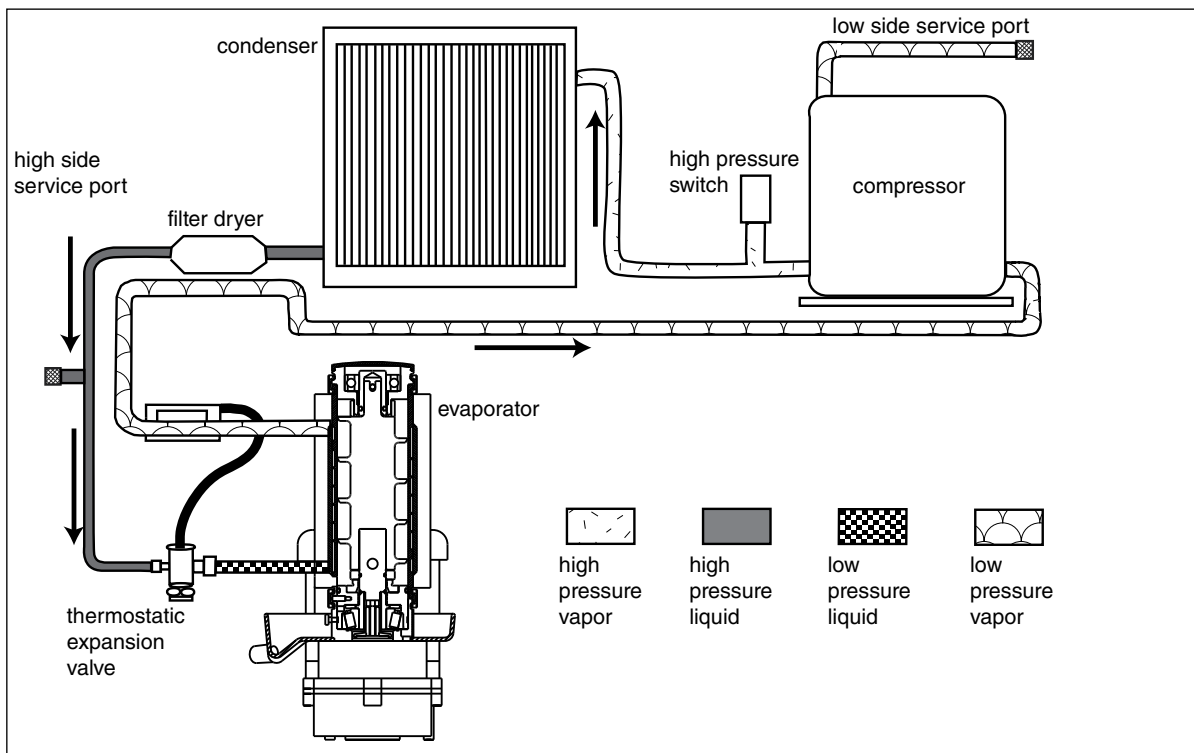

Refrigeration pressure data

Air-Cooled ice machine capacity/24hrs – 220 V/60 Hz

Ambient Air Temperature F/C

Inlet Water Temperature F/C	F	60	70	80	90	100	
	C	16	21	27	32	38	
50		418	388	357	325	294	lbs.
10		189	176	162	147	179	kg.
60		395	370	345	313	281	lbs.
16		179	168	156	142	127	kg.
70		372	353	334	301	268	lbs.
21		169	160	151	137	122	kg.
80		362	340	318	288	259	lbs.
27		164	154	144	131	117	kg.
90		352	327	302	275	249	lbs.
32		160	148	137	125	113	kg.

Air-Cooled ice machine capacity/24hrs – 230 V/50 Hz

Ambient Air Temperature F/C

Inlet Water Temperature F/C	F	60	70	80	90	100	
	C	16	21	27	32	38	
50		429	401	374	341	308	lbs.
10		195	182	170	155	140	kg.
60		407	381	355	324	293	lbs.
16		185	173	161	147	133	kg.
70		385	360	336	307	278	lbs.
21		175	163	152	139	126	kg.
80		369	346	323	295	267	lbs.
27		167	157	147	134	121	kg.
90		354	332	310	283	255	lbs.
32		161	151	141	128	116	kg.

Compressor data

Air-cooled										
Ambient air temperature	60 F/15.6 C		70 F/21.1 C		80 F/26.7 C		90 F/32.2 C		100 F/37.8 C	
	220 V	230 V	220 V	230 V	220 V	230 V	220 V	230 V	220 V	230 V
Amperage	2.7	2.2	2.8	2.3	2.9	2.5	3.0	2.6	3.1	2.8
High-side pressure (psi)	210	197	247	235	285	273	322	311	360	349
Low-side pressure (psi)	27	28	29	30	31	32	33	34	35	36

Locked rotor amps 220 V: 19.6A

230 V: 18.2A

Gearmotor data

Gearmotor current 220 V: 1.A (nominal)

230 V: 1.3A (nominal)

Locked rotor amps 6.8A

6.8A

Refrigeration system

Important: All service on refrigeration system must be performed in accordance with all federal, state and local laws that pertain to the use of refrigerants. It is the responsibility of the technician to ensure that these requirements are met.

R425 ice machine charge specifications

Model	Charge	Refrigerant type
C/E12CI425A (air-cooled)	15 oz	R404A



- Recharging of unit at other than factory specifications will void ice machine warranty.

Refrigerant replacement requirements

1. Non-contaminated refrigerant removed from any Follett refrigeration system can be recycled and returned to the same system after completing repairs. Recycled refrigerant must be stored in a clean, approved storage container. If additional refrigerant is required, virgin or reclaimed refrigerant that meets ARI standard 700-88 must be used.
2. In the event of system contamination (for example, a compressor burn out, refrigerant leak, presence of non-condensibles or moisture), the system must be repaired, evacuated and recharged using virgin or reclaimed refrigerant that meets ARI standard 700-88.
3. Follett LLC does not approve of recovered refrigerants. Improper refrigeration servicing procedures will void the factory warranty.

Evacuation

Evacuate the system to a level of 500 microns. When the 500 micron level is reached, close valves and both manifold and shut down the vacuum pump. Allow the system to sit for approximately 20 minutes. During this period the system pressure should not rise. If the system pressure rises and stabilizes there is moisture in the system and further evacuation is needed. If the pressure continues to rise check the system for leaks.

Ice capacity test

Ice machine production capacity can only be determined by weighing ice produced in a specific time period.

1. Remove top panel and hopper lid of unit.
2. Weigh and record weight of container used to catch ice.
3. Run ice machine for at least 15 minutes.
4. Catch ice for 15 or 20 minutes.
5. Weigh harvested ice and record total weight.
6. Subtract weight of container from total weight.
7. Convert fractions of pounds to decimal equivalents (Ex. 6 lbs 8 oz = 6.5 lbs).
8. Calculate production using following formula:

$\frac{1440 \text{ min.} \times \text{wt. of ice produced}}{\text{Total test time in minutes}} = \text{Production capacity/24 hr. period}$
--

9. Calculated amount per 24 hours should be checked against rated capacity for same ambient and water temperatures in Ice Production Table (see page 32).

Dispenser troubleshooting



- Disconnect power to unit before putting hands or arms in storage area or attempting any repair or service to equipment.

Before calling for service

1. Check that no ice is in the dispenser bin area.
2. Check that congealed ice is not causing a jam
3. Check that all switches and circuit breakers are on
4. Check that all drains are clear.
5. Check water is supplied.

Lever model troubleshooting guide

Problem	Indicators	Corrective Action
Does not dispense ice.	<ol style="list-style-type: none"> 1. Power switch off or faulty. 2. Faulty dispense switch. 3. Wheel motor malfunction. 	<ol style="list-style-type: none"> 1. Check switch – turn on or replace if faulty. 2. Replace switch. 3. Check motor and replace
Dispense wheel rotates continuously.	Dispense switch contacts are burned out.	Replace dispense switch.
Ice machine runs continuously.	Faulty or incorrectly positioned bin stat.	Check for proper positioning. If stat does not open when ice is placed on capillary tube, replace stat.
Does not dispense water.	<ol style="list-style-type: none"> 1. Faulty water solenoid valve. 2. Faulty dispense switch. 3. Power switch off or faulty. 	<ol style="list-style-type: none"> 1. Replace water solenoid valve. 2. Replace dispense switch. 3. Check switch - turn on or replace if faulty.

SensorSAFE model troubleshooting guide

Problem	Action	SensorSAFE Board LED Status			Corrective Action
		PWR	CLN	ICE/WTR	
Does not dispense ice and/or water.	Check LEDs on the SensorSAFE control board.	OFF	OFF	OFF	Check circuit breakers and power switch. Restore power or replace defective switch.
		ON	ON	OFF	Press clean switch on lower left side of electrical enclosure to return board to normal operation.
	Place cup under drop zone (in front of lens)	ON	OFF	OFF	Troubleshoot appropriate lens/sensor and replace if required (see lens/sensor troubleshooting).
		ON	OFF	ON	Verify power on appropriate output terminal (WTR or WM) on control board and replace board if required. If board tests okay, troubleshoot appropriate dispenser component.
Dispenses ice and/or water continuously.	Check LEDs on control board.	ON	OFF	ON	Troubleshoot appropriate lens/sensor and replace if required (see lens/sensor troubleshooting).
		ON	OFF	OFF	If there is power on any output terminal 9WTR or WM) on control board, replace board.

SensorSAFE board guide

LEDs, when illuminated, indicate the following: PWR (board power), CLN (clean button pressed WTR and WM outputs disabled), ICE (ice dispensing activated), WTR (water dispensing activated).

Terminals: L1 (incoming power, hot), L2 (neutral terminals), WTR (power terminal for water solenoid), WM (power terminal for wheelmotor), CLN (terminals for clean cycle switch).

Note: SOL terminal not used in 12 series dispensers.

Lens/sensor troubleshooting

1. Turn dispenser power switch off and remove splash panel.
2. Disconnect wires from WTR and WM terminals on board.
3. Gently remove sensor/mounting block from splash panel.
4. Inspect lens and sensor, clean if necessary.
5. Restore dispenser power and test sensor by passing hand in front of sensor.
6. If LED on board turns on, sensor is operational. Re-assemble dispenser.
7. If LED does not come on switch sensor leads on board and retest.
8. If opposite LED comes on – replace defective board.
9. If opposite LED does not come on – replace defective sensor.

Fig. 11

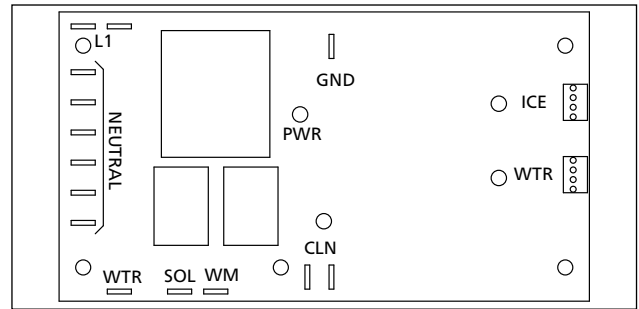

Disassembly and replacement instructions

Dispense wheel removal

1. Remove all ice from storage area of dispenser.
2. Remove center thumbscrew (**Fig. 18.1**), locking plate (**Fig. 18.2**), two wingnuts (**Fig. 18.3**) and backing plate (**Fig. 18.4**) from front of storage hopper (see drawing at right).
3. Remove threaded rod (**Fig. 18.5**), agitator (**Fig. 18.6**), baffle (**Fig. 18.7**), and wheel (**Fig. 18.8**) in this sequence.

Wheelmotor removal

1. Remove dispense wheel.
2. Remove four (4) dispenser motor bracket mounting screws and washers (**Fig. 19.1**).
3. Remove (4) screws holding motor to mounting bracket (**Fig. 19.2**).

Fig. 12

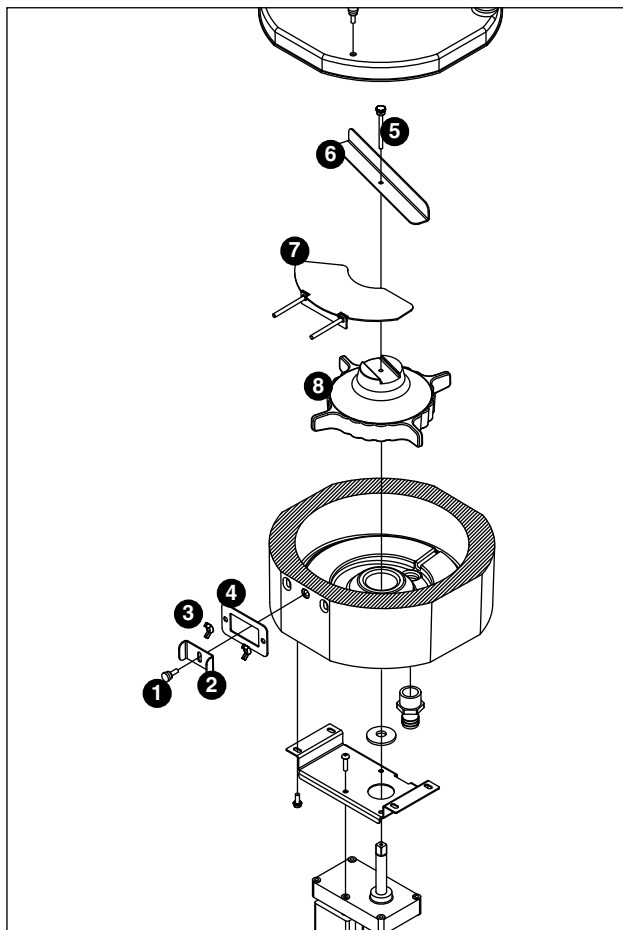
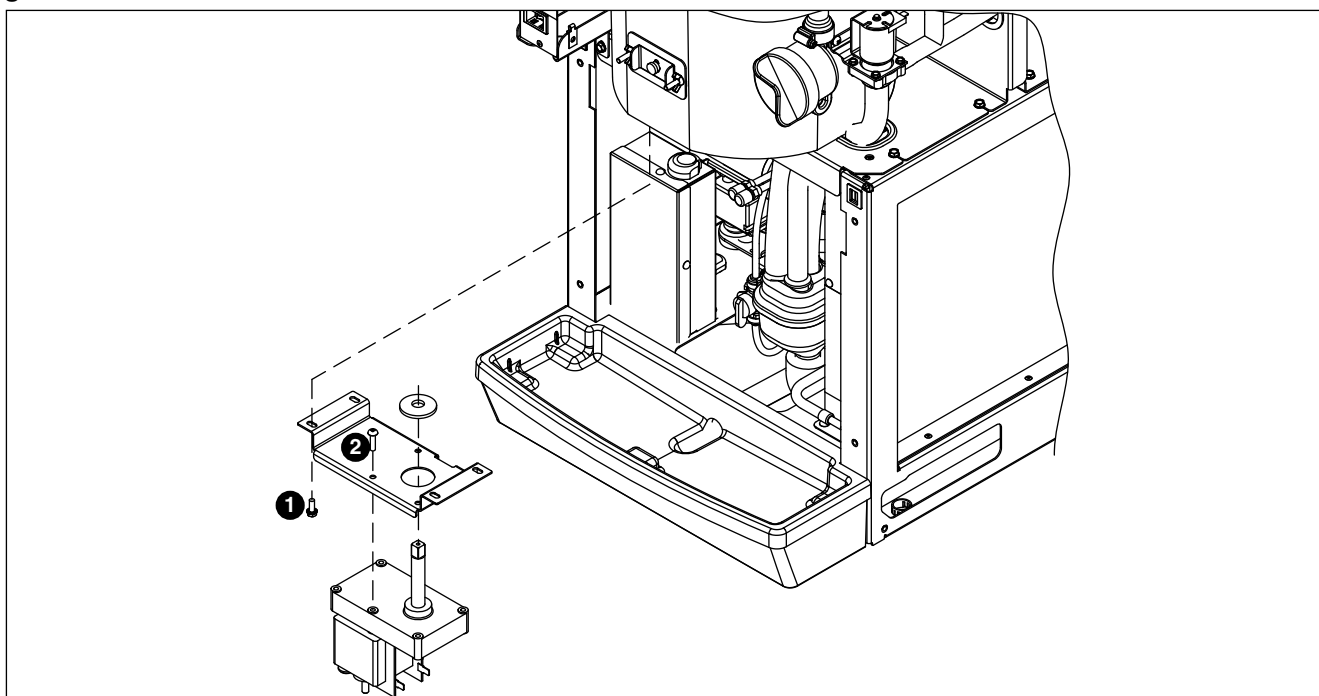

Fig. 13



Evaporator disassembly

Note: The upper bearing, lower bearing and auger assemblies must be replaced as assemblies. The bottom and top bearing assemblies cannot be field assembled to factory specifications.

1. Press **CLEAN** switch.
2. Wait for **LOW WATER** light to illuminate.
3. Turn OFF power.
4. Remove top bearing insulation.
5. Remove compression nozzle insulation.
6. Disconnect vent and drain tube from nozzle.
7. Disconnect compression nozzle from evaporator.
8. Disconnect evaporator water feed line.
9. Remove nut and upper vee band coupling from top of evaporator.
10. Lift top bearing assembly straight up with a slight rotating motion and remove.
11. Remove ice compression loop located at top of auger.
12. Lift auger straight up and out of evaporator.
13. Remove nut and lower vee band coupling from bottom of evaporator.
14. Lift evaporator to clear bottom bearing assembly.
15. Loosen hex head bolt in side of mounting base with 5/16 wrench and lift lower bearing assembly.
16. Remove condensate shield.
17. Remove 4 Allen head machine screws holding mounting base to gearbox.

Fig. 14

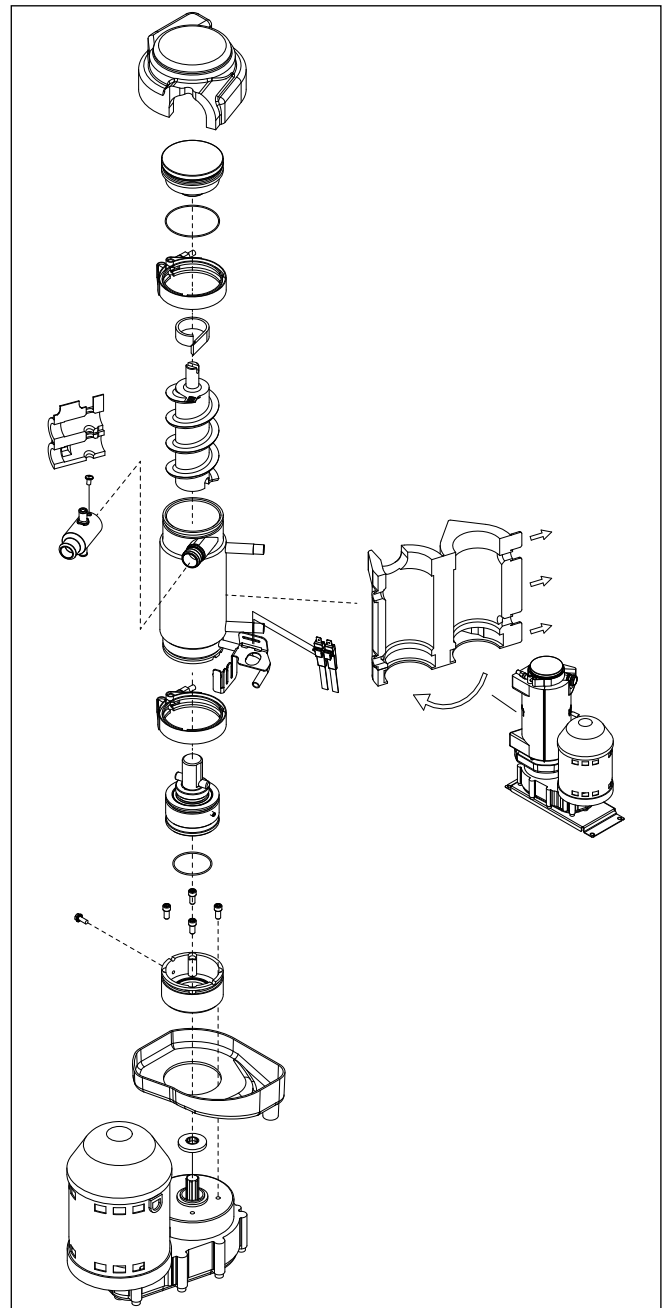

Evaporator reassembly

1. Clean gearmotor boss, output shaft and shaft well.
2. Install drain pan and evaporator mounting base.
3. Fill gearmotor shaft well with food grade grease (**Fig. 21**).
4. Install condensate shield and seat against gearmotor boss.
5. Install bearing O ring in groove in evaporator mounting base.
6. *While maintaining firm downward pressure on bottom bearing assembly*, tighten hex head bolt with a 5/16 wrench.
7. Position evaporator over lower bearing assembly and align grooves with pins in bearing assembly.
8. Install vee band clamp and nut to 70 in/lb. (**Fig. 22**).
Note: Clamp **must be oriented as shown** in order for the insulation to be placed properly.
9. Place auger in center of evaporator and rotate to mate with drive pin.
10. Install ice compression loop, orienting loop.
11. Install upper bearing and seal assembly, rotating bearing to slip pin into auger slot.
12. Install upper vee band clamp and nut to 70 in/lb.
13. Install compression nozzle and tubing.
14. Secure ice transport tube with clamp (**Fig. 23.1**).
Note: Clamp **must be oriented as shown** in order for the insulation to be placed properly.
15. Install compression nozzle insulation (**Fig. 23.2**).
16. Install vent and drain tube (**Fig. 23.3**).
17. Install top bearing insulation (**Fig. 23.4**).

Gearmotor replacement

1. Disassemble evaporator.
2. Disconnect the wire connectors.
3. Remove 4 screws holding gearmotor mounting plate to base of ice machine and lift gearbox and motor clear of ice machine.
4. Remove machine screws holding mounting plate to motor.
5. Install new motor in reverse order.

Fig. 15

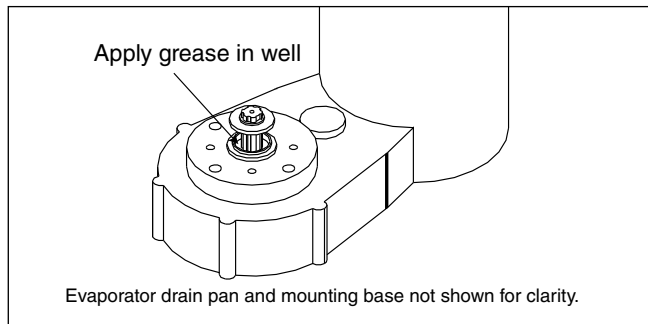

Fig. 16

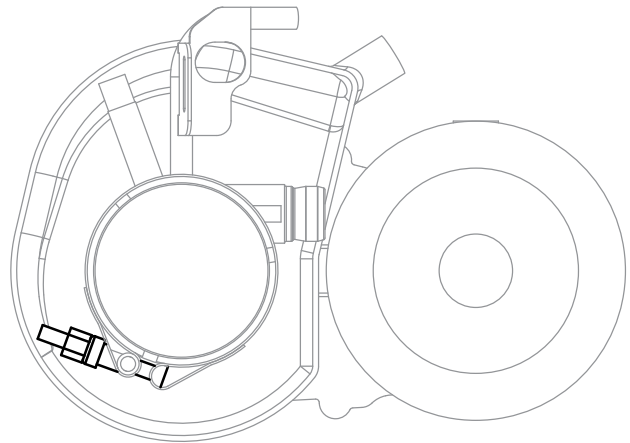
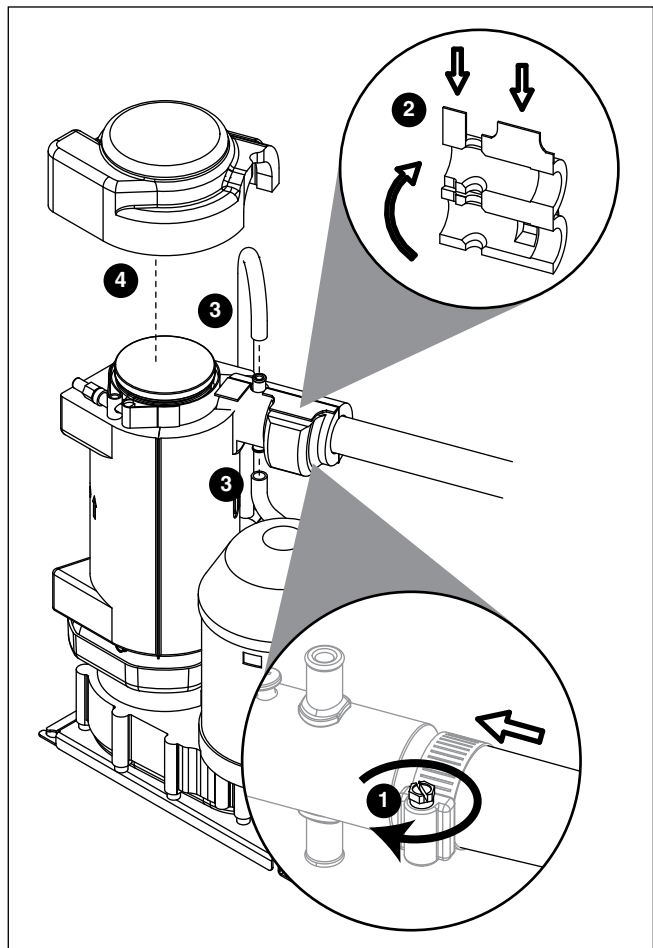

Fig. 17



Fan removal

1. Remove 4 fan mounting screws and 3 drain tubes from bracket.

Fig. 18

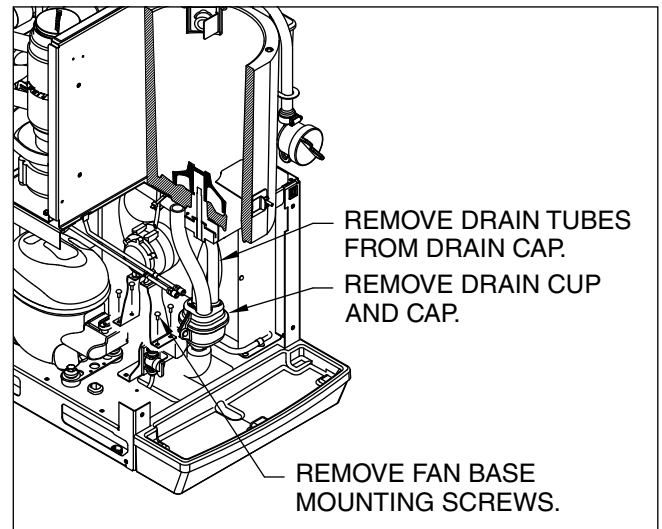

2. Rotate fan mounting bracket toward back of unit and pull fan assembly toward front of unit.

Fig. 19

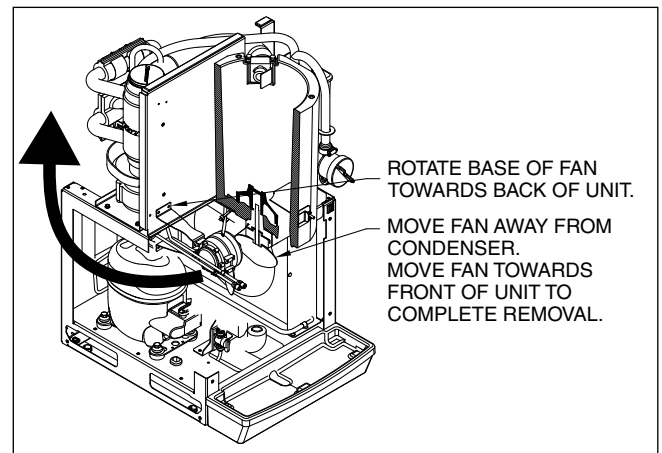

Thermostat and ice transport tube replacement

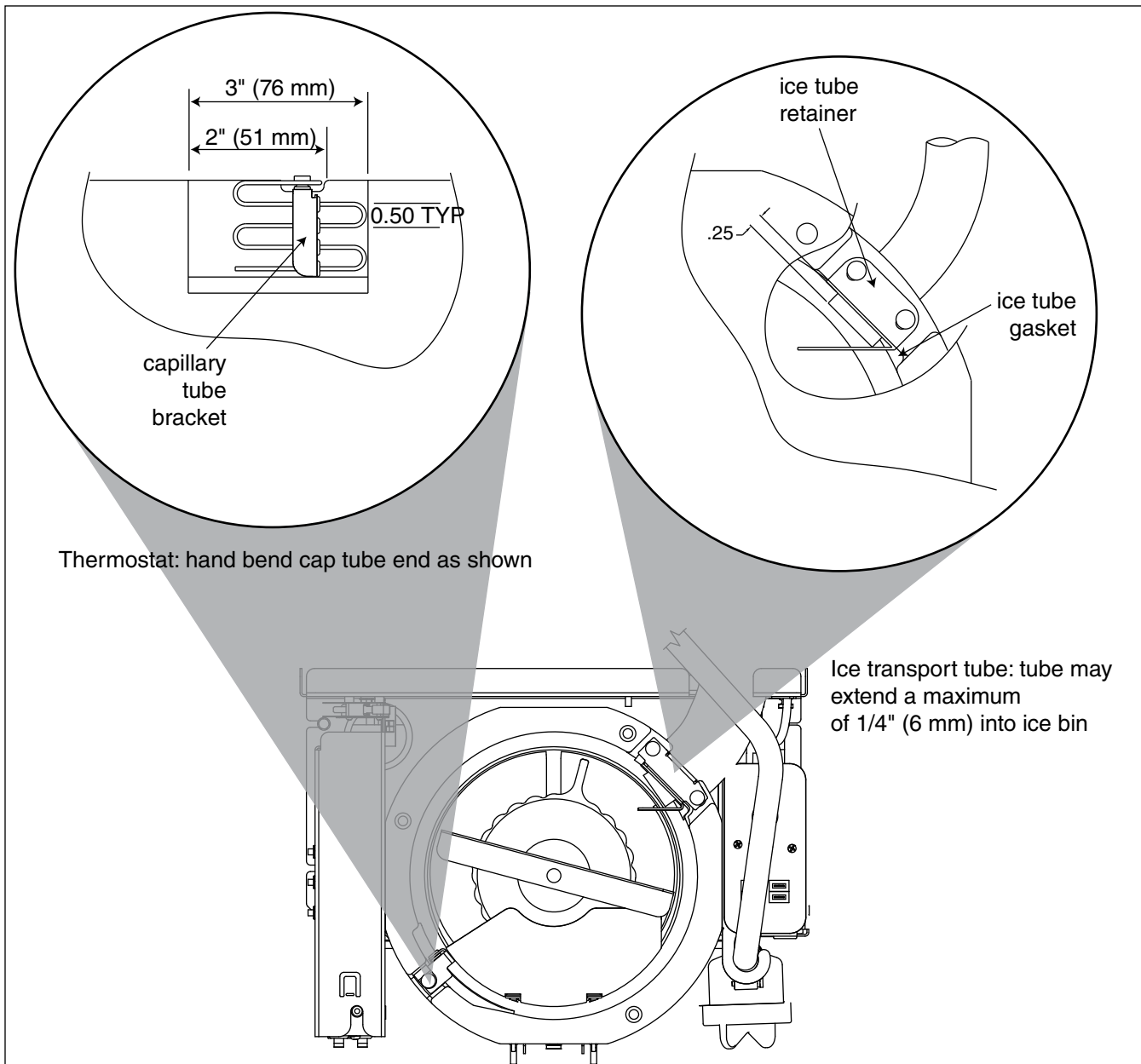

Ice transport tube replacement

1. Refer to Fig. 23..

Replacement parts

Dispenser exterior

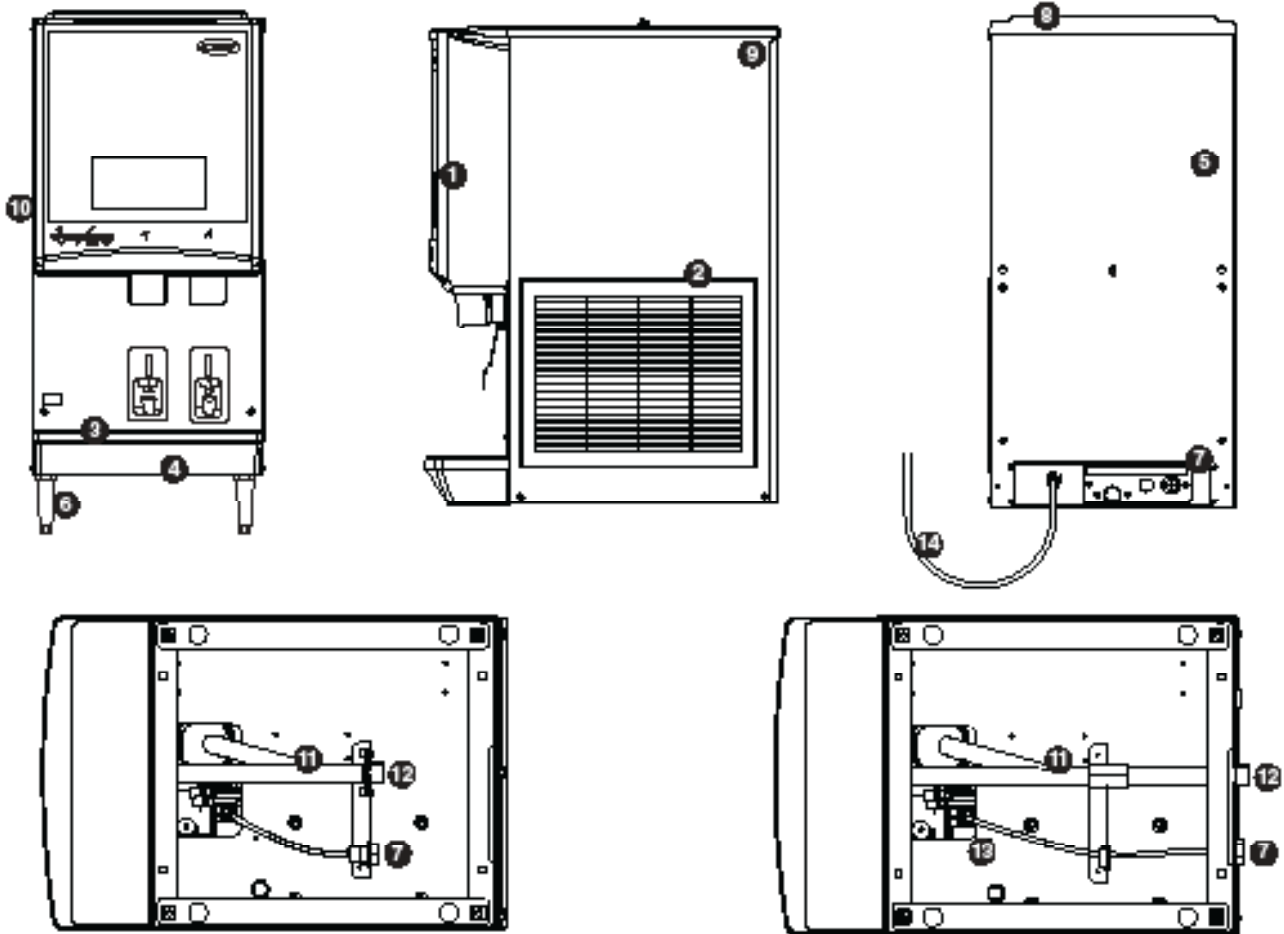

Reference #	Description	Part #
1	Cover, front, ice and water	01064575
Not shown	Cover, front, ice only	01064583
2	Louver, intake, plastic	00967117
Not shown	Grille, drain pan, gray plastic	01051614
3	Drain pan, plastic	00967059
4	Drain pan assembly (includes hardware, pan and grille)	502410
5	Panel, rear	502394
6	Leg kit, 4" (10.2 cm), adjustable – set of 4	502399
7	Fitting, water inlet, brass 3/8" FPT x 1/4" john guest	01065275
8	Lid, top panel, plastic	00967091
9	Panel, right side	502396
10	Panel, left side	502395
11	Tube, drain pan/collector cup	01065390
12	Fitting, drain	00109728
13	Valve, 1/4" john guest	01035526
14	Cord, power	01111681
Not shown	Bracket, wall 16" (40.6 cm)	502873
Not shown	Clip, valve	01035534
Not shown	Grille, drain pan - case of 12	01071224

Wheelmotor and drive system

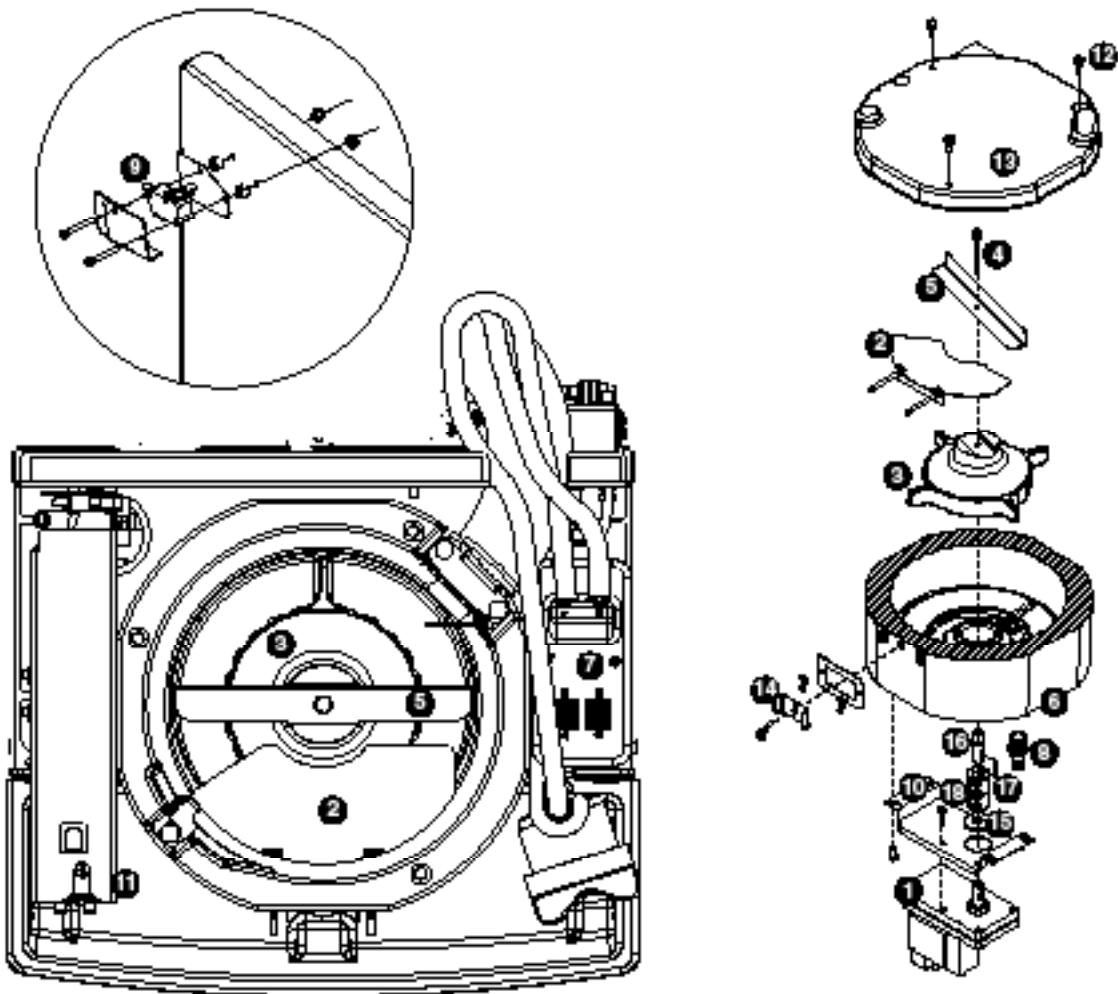

Reference #	Description	Part #
1	Motor, wheel, short shaft (includes gear motor shield)	502933
2	Baffle, ice (securing hardware, part# 00167973, included)	502414
3	Wheel with Agion, agitator	502387
4	Rod, threaded (includes knurled nut)	502390
5	Agitator, rotating	502386
See page 35	Bracket, capillary tube	502406
See page 35	Retainer, ice tube	00977314
Not shown	Gasket, ice tube	01148782
6	Assembly, hopper with Agion (includes drain fitting)	502413
7	Reservoir assembly	01148741
8	Fitting, hopper drain, 3/4 MPT, 3/4" barb fitting	207095
9	Switch, interlock	502416
10	Support plate, motor	502423
11	Cover, electrical box	502408
12	Screws, 10-32 x 1/2 (6 needed)	201022
13	Hopper lid with hopper lid safety switch actuation	00135962
14	Hardware, baffle securing	00167973
15	Shield, gear motor	502537
16	Drive shaft extension	502384
17	Key, 1/8" sq x 1-1/4 lg	501273
18	Coupling (includes key) (short shaft motor only)	502385
Not shown	Gasket, reservoir	01148766

Dispense chute and splash panel (models with lever dispensing)

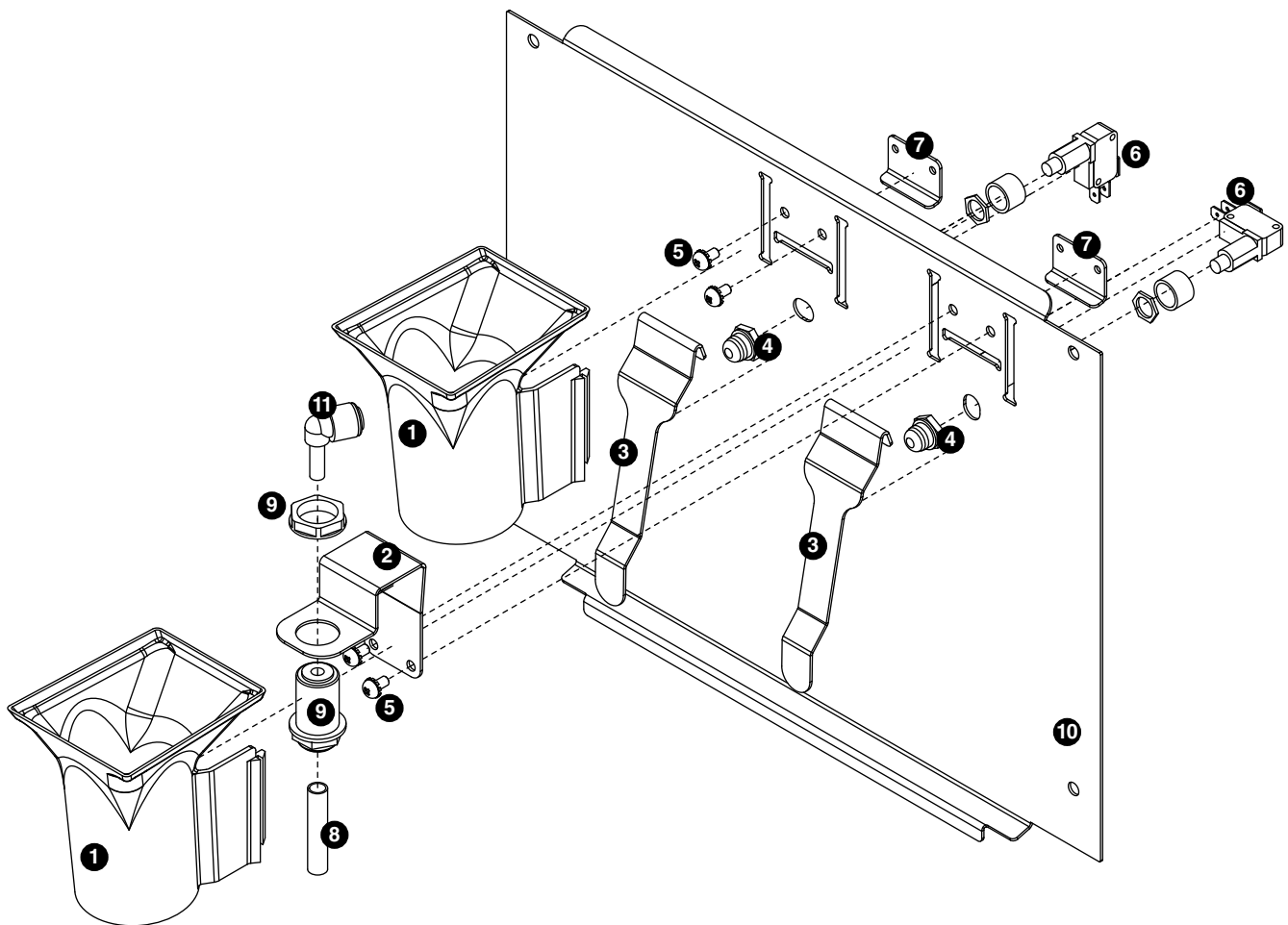

Reference #	Description	Part #
1	Chute, ice or water (with Agion® antimicrobial product protection ¹)	00967760
2	Support, water tube	00960682
3	Lever	00976845
4	Boot, dispense switch button	502418
5	Screw, panel	00982421
6	Switch, dispense	00981217
7	Bracket, lever support	00958793
8	Tube, water solenoid	502420
9	Fitting, bulkhead (with nut)	00976787
Not shown	Splash panel (ice only)	01161249
10	Splash panel	00969980
11	Fitting, 1/4" stem x 1/4" push-in	01161256

¹ Disclaimer: Antimicrobial protection is limited to the treated components and does not treat water or ice. Agion is a registered trademark of Sciesent LLC.

Dispense chute and splash panel (models with SensorSAFE infrared dispensing)

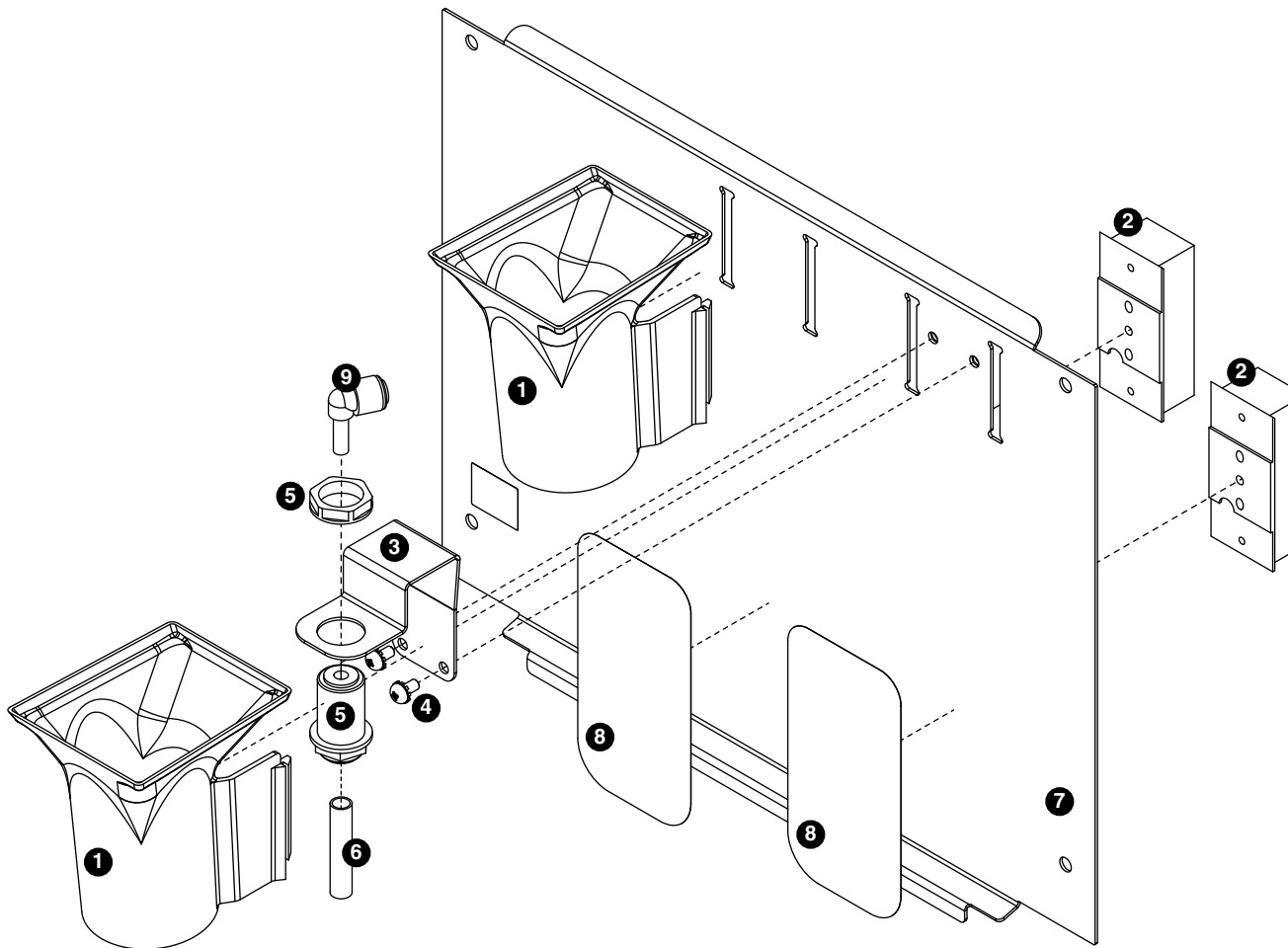

Reference #	Description	Part #
1	Chute, ice or water (with Agion)	00967760
2	Sensor (includes lens and Ty-rap*)	00122978
3	Support, water tube	00960682
4	Screw, panel	00982421
5	Fitting, bulkhead (with nut)	00976787
6	Tube, water solenoid	502420
7	Splash panel	01161264
8	Lens, sensor (each)	502690
Not shown	Splash panel, ice only	01161272
9	Fitting, 1/4" stem x 1/4" push-in	00121699

* Ty-rap is a registered trademark of Thomas & Betts International, Inc.

Electrical components

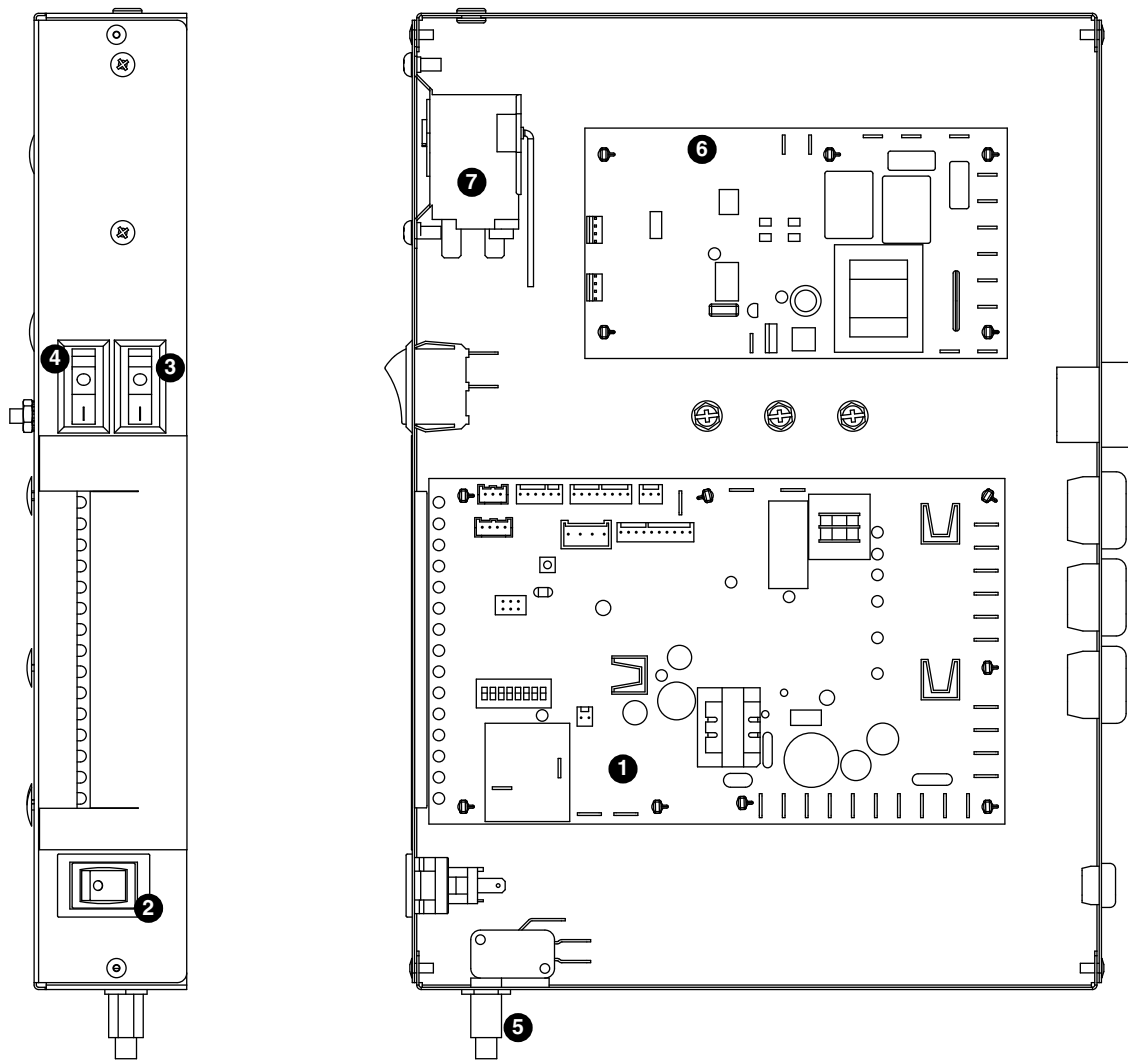

Reference #	Description	Part #
1	Board, control circuit, 230 V, 50 Hz and 220 V, 60 Hz	01111657
2	Switch, clean	00117036
3	Switch, rocker, power	502209
4	Switch, rocker, bin signal	502209
5	Switch, cleaning, SensorSAFE models	502409
6	Control board, SensorSAFE models	502915
7	Bin thermostat	500514

Ice machine components

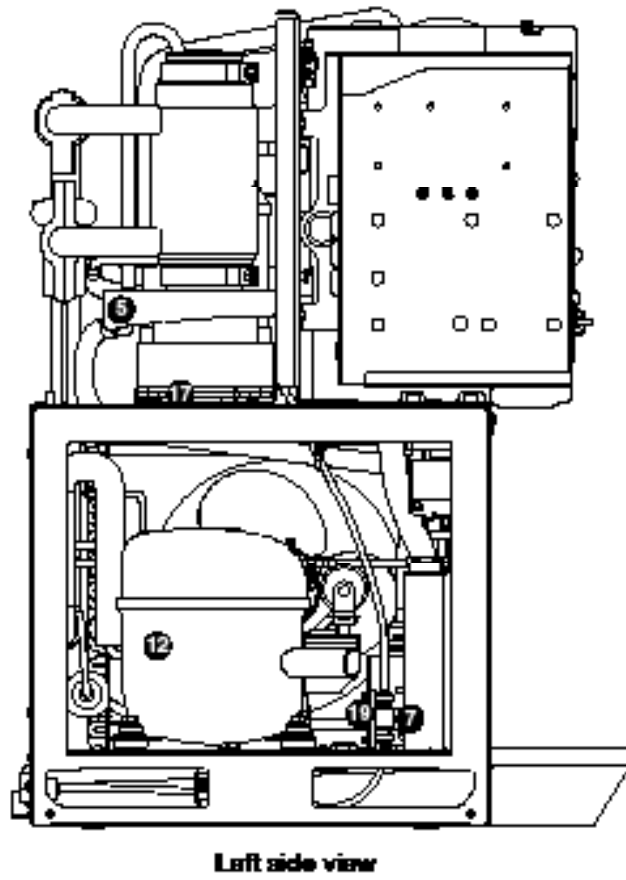
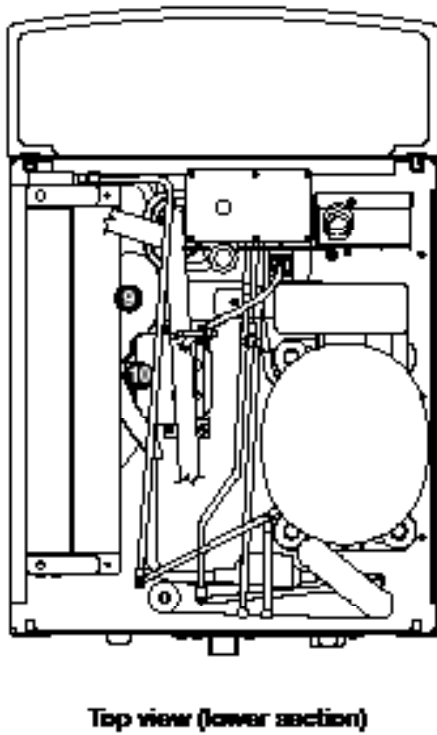
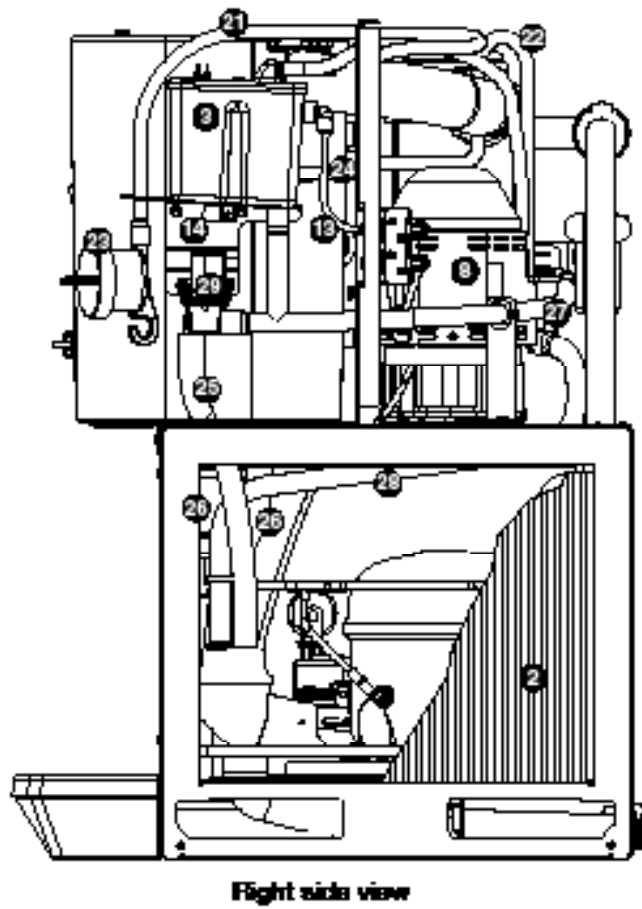
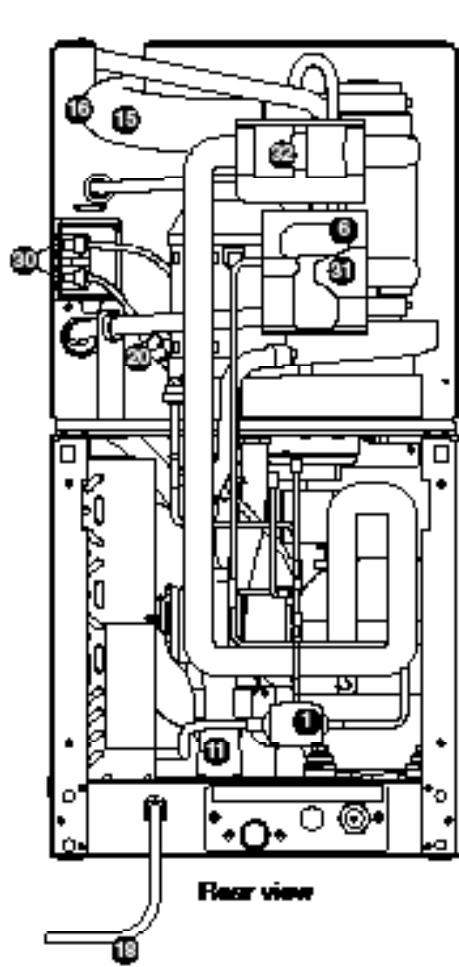

Reference #	Description	Part #
1	Drier	502724
2	Coil, condenser (includes shroud)	01065317
3	Reservoir (includes lid, gasket, fasteners, clean and vent tubing, cleaning cup)	01230630
Not shown	Gasket, reservoir	01148766
4	Evaporator (see page 48 for detailed drawing)	—
5	Drain pan, evaporator	502727
6	Valve, expansion, thermal	502726
7	Valve, shut-off, water, plastic, 1/4"	01035526
8	Gearbox & motor, 230 V, 50 Hz and 220 V 60 Hz (includes 307192)	502832
9	Fan blade	01191410
10	Motor, fan, 230 V, 50 Hz and 220 V 60 Hz	00149765
11	Bracket, fan motor	01067107
Not shown	Overload, compressor, 230 V	01087188
12	Compressor, 230 V, 50 Hz	01111665
12	Compressor, 220 V, 60 Hz, internal overload	01148527
13	Tubing, polypropylene, reservoir supply (sold by the foot)	502079
14	Bracket, reservoir	01065408
15	Tube, ice transport per foot (13" required)	01148642
16	Insulation, ice tube, 12" (30.5 cm) required	501176
17	Mounting base, gearmotor	01072891
18	Cord, power	01111681
19	Clip, water shut-off valve	01035534
20	Tee, water, 1/4"	502923
Not shown	Gasket, ice hose	00977322
21	Tube, clean cup	01165364
22	Tubing, nozzle vent	01148691
23	Cleaning cup	01065226
24	Tubing, nozzle drain	01148790
25	Tubing, purge	01054790
26	Tubing, bin	01054782
27	Tubing, evaporator fill	00998740
28	Tubing, evaporator drain pan	01054154
29	Solenoid, purge	01148733
30	Solenoid, fill, dispense	01111699
31	Insulation, TEV	502830
32	Insulation, TEV bulb	00106534
33	Tubing, reservoir vent, per foot (21.5" required)	01165372
Not shown	Hi-pressure cut-out	502732

Compressor - 230 V 50 Hz

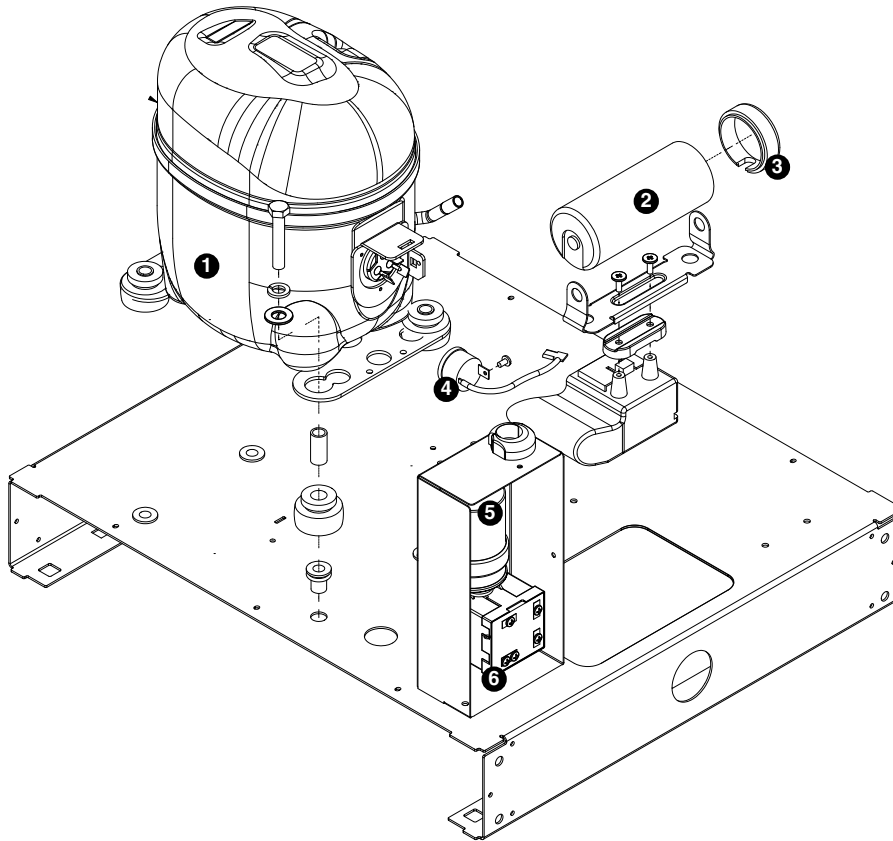

Reference #	Description	Part #
1	Compressor, 230 V (includes start cap, run cap, and start relay)	01111665
2	Capacitor, start	01036748
3	Cap, end	01027556
4	Overload, compressor	01087188
5	Capacitor, run	01087162
6	Relay, start	01087154

Compressor - 220 V 60 Hz

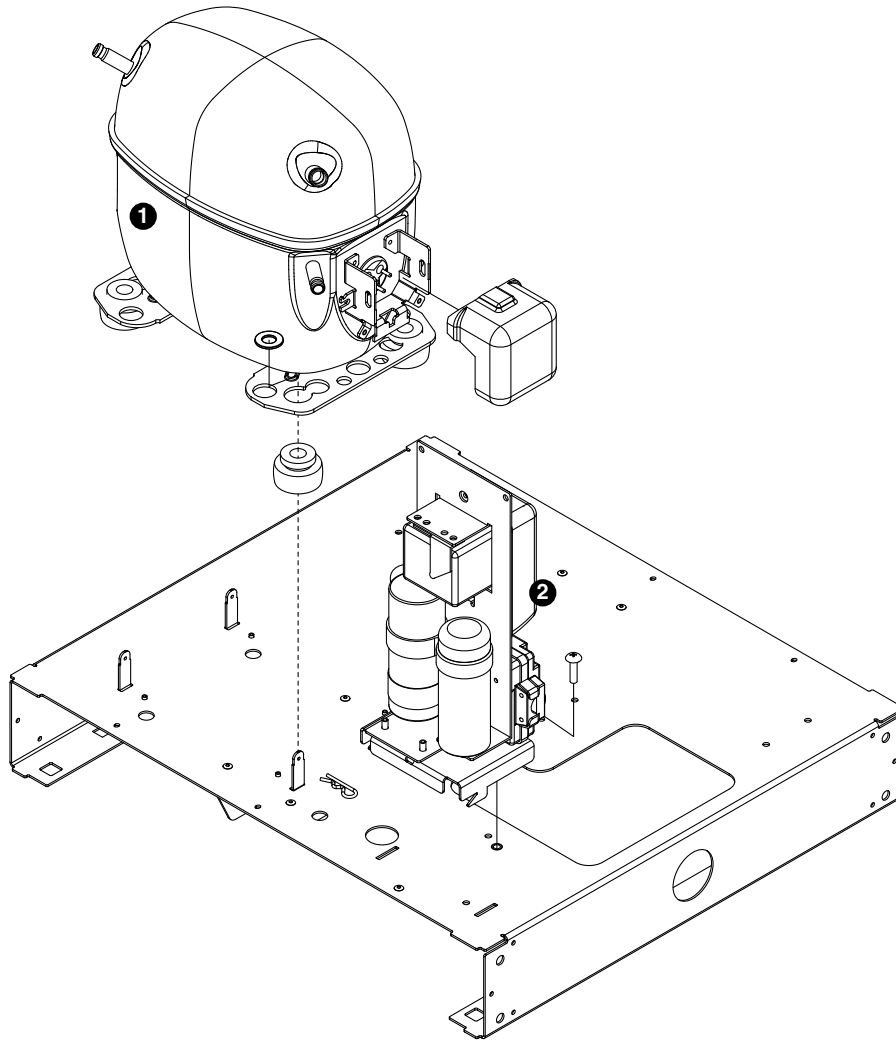

Reference #	Description	Part #
1	Compressor, 220 V, 60 Hz, internal overload (includes start cap, run cap, and start relay)	01148527
2	Box, electrical, start/run components, 220 V, 60 Hz	01148535

Evaporator replacement parts

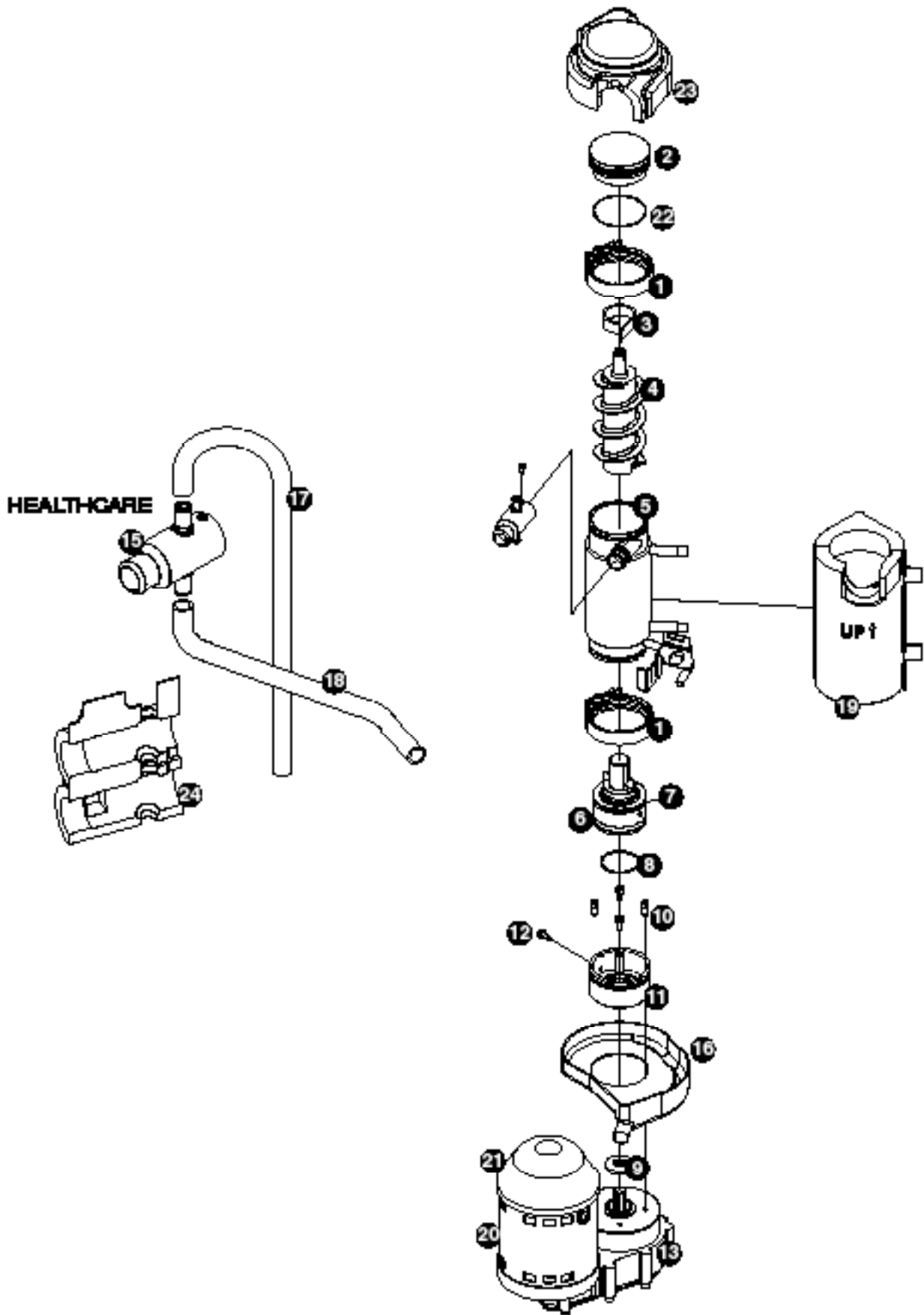

Reference #	Description	Part #
1	Coupling, vee band, includes nut	502735
2	Bearing assembly, top	502736
3	Loop, ice compression, beveled	502110
4	Auger (see below for Flaker-specific components)	502737
5	Evaporator (includes insulation jacket, and top bearing insulation)	01064658
6	Bearing assembly, bottom (includes O rings and condensate shield)	502738
7	O ring, bearing housing	500496
8	O ring, mounting base	501063
9	Shield, condensate	500744
10	Screw, Allen 1/4 20 x 1/2 (set of 4)	501080
11	Mounting base, evap. (includes 501063)	502733
12	Bolt, mounting base	502227
13	Gearbox & motor (includes mounting base) 230 V 50 Hz and 220 V 60 Hz	502832
Not shown	Mounting base, gearmotor	01072891
15	Compression nozzle, with single drain	01064674
16	Drain pan, evaporator	00181990
17	Tube, compression nozzle vent	01148691
18	Tube, compression nozzle, single drain	01148790
Not shown	Grease, Mobil FM222, 14 oz	501111
19	Insulation jacket, evaporator	01049592
20	Relay, gearmotor	00120055
21	Cover, black plastic	01012228
22	O ring, top bearing	01064963
23	Insulation, top bearing	01049600
24	Insulation, compression nozzle, single drain	01049584

Water supply and drains

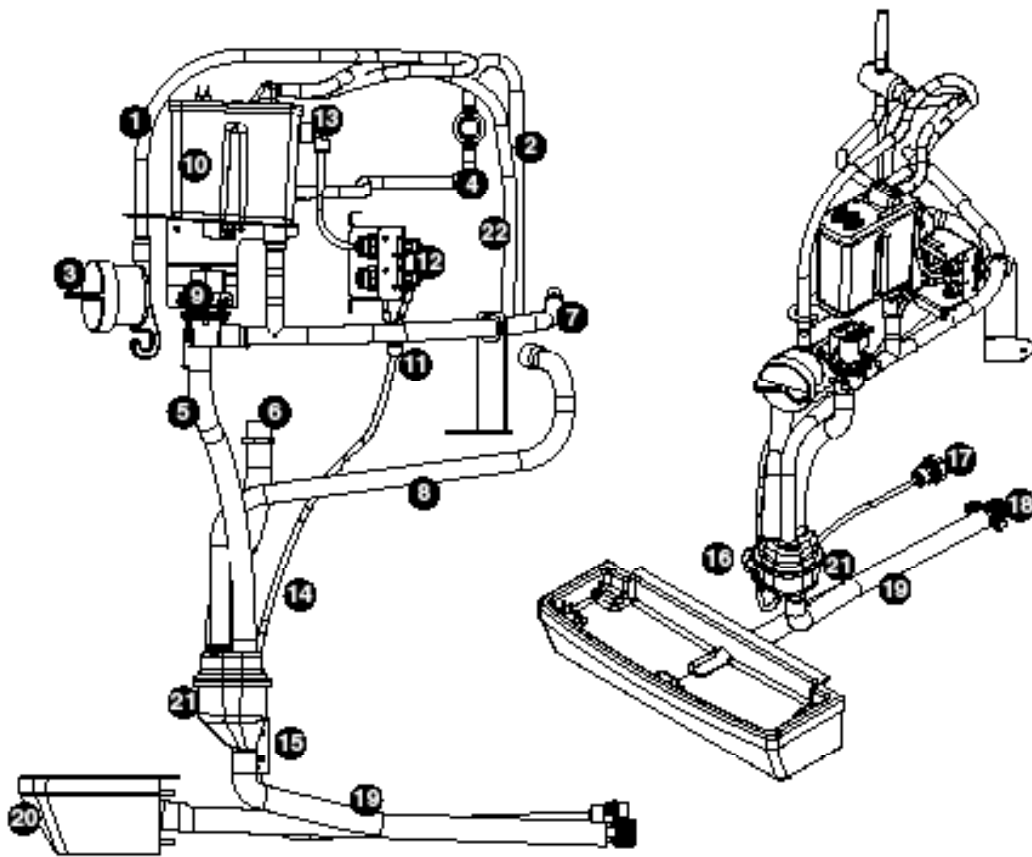

Reference #	Description	Part #
1	Tube, reservoir clean, per foot (33" required)	01165364
2	Tube, nozzle vent	01148691
3	Cup, clean	01065226
4	Tube, nozzle drain	01148790
5	Tube, purge	01054790
6	Tube, bin	01054782
7	Tube, evaporator fill	00998740
8	Tube, evaporator drain pan	01054154
9	Solenoid, purge	01148733
10	Reservoir (includes lid, gasket, fasteners, clean and vent tubing, cleaning cup)	01230630
11	Tee, water, 1/4"	502923
12	Solenoid, fill, dispense	01111699
13	Fitting, 1/4" stem x 1/4" push-in	00121699
14	Tubing, 1/4"	502079
15	Clip, 1/4" valve	01035534
16	Valve, 1/4"	01035526
17	Fitting, 3/8" FPT x 1/4" push-in	01065275
18	Fitting, 3/4" MPT x 3/4" barb	00109728
19	Tube, drain pan/collector cup	01065390
20	Drain pan	00967059
21	Cup, drain	01064690
Not shown	Bracket, drain cup	01051945
22	Tube, reservoir vent, per foot (21.5" required)	01165372
Not shown	Valve, check, 1/4"	01122381

Water treatment accessories for Symphony Plus ice and water dispensers

Reference #	Description	Part #
Standard capacity filter system		
Not shown	Follett QC4-FL4S water filter system (includes FL4S primary cartridge and head, coarse pre-filter and head, pressure gauge, flushing valve; assembled and installed on mounting bracket), one per ice machine	00130229
Not shown	Follett FL4S primary replacement cartridge	00130245
Not shown	Water filter cartridge – primary, carton of 6	00954297
Not shown	Everpure coarse pre-filter cartridge	00130211
Not shown	Water pre-filter cartridge – pre-filter, carton of 12	00954305
High capacity filter system		
Not shown	High capacity water filter system (one per ice machine)	00978957
Not shown	High capacity water filter cartridge – primary, single	00978965
Not shown	High capacity water filter cartridge – primary, carton of 6	00978973
Not shown	Water pre-filter cartridge – pre-filter, single	00130211
Not shown	Water pre-filter cartridge – pre-filter, carton of 12	00954305
Carbonless high capacity filter system		
Not shown	Carbonless high capacity water filter system (one per ice machine) – Horizon™ and MaestroPlus series ice machines	01050442
Not shown	Carbonless high capacity water filter cartridge – primary, single	01050426
Not shown	Carbonless high capacity water filter cartridge – primary, carton of 6	01050434
Not shown	Water pre-filter cartridge – pre-filter, single	00130211
Not shown	Water pre-filter cartridge – pre-filter, carton of 12	00954305
Other filtration		
Not shown	Claris hardness removal filtration system	00986059
Not shown	Replacement filter for Claris system	00985127
Not shown	Reverse osmosis system, 200 gallons per day	00986034
Not shown	Replacement reverse osmosis cartridge	00985085
Not shown	Replacement reverse osmosis pre-filter	00985077
Not shown	Cleaning plug for reverse osmosis system	00985119
Not shown	Cleaning cartridge for reverse osmosis system	00985101
Water pressure		
Not shown	Water pressure regulator (25 psi)	501781
Cleaning/Sanitizing		
Not shown	SafeCLEAN Plus ice machine cleaner and sanitizer, carton of 24 x 7 oz packets	01050863
Not shown	Sponge, sanitary, each	00131524
Not shown	Sponge, sanitary, pack of 24	01075431

Rejestracja gwarancji i ocena sprzętu

Dziękujemy za zakup urządzenia firmy Follett. Mamy nadzieję, że nasze urządzenia spełniają i przekraczają Państwa oczekiwania, gdyż naszym celem jest dostarczenie klientom wysoce wartościowych produktów i usług, zasługujących na ich pełne uznanie.

Prosimy zapoznać się z załączoną instrukcją instalacji i obsługi. Istotne jest przeprowadzenie instalacji zgodnie z wymogami producenta, co zapewni działanie urządzenia z maksymalną wydajnością.

Follett LLC nie będzie ponosić odpowiedzialności za szkody wtórne, wydatki, koszty podłączania lub odłączania lub jakiegokolwiek straty wynikające z wady urządzenia.

Aby uzyskać szczegółowe informacje na temat warunków gwarancji, prosimy odwiedzić naszą stronę internetową www.follettice.com/productwarranties.

Rejestracja gwarancji i ocena urządzenia to istotne czynności, ułatwiające nam utrzymanie aktualnych danych o miejscach instalacji naszych urządzeń i o ich działaniu. Prosimy o zarejestrowanie gwarancji na nabyte urządzenie firmy Follett na naszej witrynie www.follettice.com/support, gdzie należy wybrać Warranty Registration (Rejestracja gwarancji) i Equipment Evaluation (Ocena urządzenia). Jest to łatwe i nieskomplikowane, prosimy o zrealizowanie na to paru minut jeszcze dzisiaj. Na formularzu jest również miejsce na przekazanie nam komentarzy i informacji zwrotnych. Proszę podzielić się z nami swoimi wrażeniami, abyśmy mogli wykorzystać je w naszych ciągłych dążeniach do usprawnień.

Jesteśmy dumni z naszych znakomitych urządzeń i staramy się usilnie wspierać je znakomitą obsługą klienta i wsparciem technicznym. Chcielibyśmy wiedzieć, w jaki jeszcze sposób moglibyśmy Państwu pomóc. Z przyjemnością odpowiemy na Państwa pytania.

Registro de Garantía y Evaluación del Equipo

Gracias por haber elegido este producto Follett®. Esperamos que nuestro equipo cumpla o supere sus expectativas porque es nuestro objetivo ofrecer productos y servicios de gran valor que se ganen su plena confianza.

Le rogamos consulte el manual de instalación y de instrucciones adjunto, ya que es muy importante que la instalación se realice según las especificaciones de fábrica para que el equipo funcione a su máxima eficiencia.

Follett LLC no se hace responsable de los daños indirectos, costos, gastos por conexión y desconexión o pérdidas por causa de defecto de la máquina.

Si desea una información más completa sobre la garantía, visite nuestro sitio web www.follettice.com/productwarranties.

Las operaciones de registro de la garantía y evaluación del equipo son importantes para que podamos realizar un seguimiento de nuestro equipo y registrar el rendimiento de la maquinaria. Por favor, registre las garantías del equipo Follett en nuestro sitio web www.follettice.com/support y seleccione Registro de la Garantía y Evaluación del Equipo. Es muy sencillo, solo le llevará un momento realizar hoy mismo el registro. En el formulario incluimos un espacio en blanco para sus comentarios y opiniones. Infórmenos sobre su experiencia para que podamos incorporarla a nuestros continuos esfuerzos de mejora.

Nos enorgullecemos de producir un equipo excepcional y trabajamos duro para respaldarlo con un soporte técnico y un servicio de atención al cliente de primera. Le rogamos nos indique qué más podemos hacer para ayudarlo. Estaremos encantados de responder a sus dudas.

Enregistrement de la garantie et évaluation de l'équipement

Merci d'avoir acheté un équipement Follett®. Notre objectif étant d'offrir des produits et des services de grande valeur vous satisfaisant pleinement, nous espérons que celui-ci satisfera, voire dépassera, vos attentes !

Veuillez consulter le manuel d'installation et d'exploitation. Il est important que l'installation soit réalisée conformément aux spécifications de l'usine, de sorte que votre équipement fonctionne à son rendement maximum.

Follett LLC n'est pas responsable de tout dommage consécutif, de toute dépense, de tout frais de raccordement ou de déconnexion, ni de toute perte liée à un défaut de la machine.

Pour lire la garantie dans son ensemble, visitez notre site Internet www.follettice.com/productwarranties.

L'enregistrement de la garantie et l'évaluation de l'équipement sont importants pour nous aider à suivre notre équipement et pour enregistrer les performances de la machine. Nous vous demandons donc d'enregistrer la garantie de votre équipement Follett sur notre site Internet, www.follettice.com/support, dans la section Warranty Registration and Equipment Evaluation. Cette opération est simple ; veuillez prendre un moment pour la réaliser aujourd'hui.

Le formulaire contient également un espace pour nous faire parvenir vos commentaires et un retour d'informations. Veuillez nous faire part de votre expérience pour que nous puissions prendre appui dessus pour poursuivre nos efforts constants d'amélioration.

Nous sommes fiers de produire des équipements exceptionnels et nous travaillons avec acharnement pour y associer une assistance à la clientèle et technique exceptionnelle. N'hésitez pas à nous indiquer dans quelle mesure nous pouvons vous aider. Nous serions ravis de répondre à vos questions.

Garantieregistrierung und Produktbeurteilung

Vielen Dank, dass Sie sich für ein Follett®-Produkt entschieden haben. Wir hoffen, dass unser Produkt Ihre Erwartungen erfüllen oder sogar übertreffen wird, weil wir uns zum Ziel gesetzt haben, hochwertige Produkte und Leistungen anzubieten, die Ihre uneingeschränkte Anerkennung verdienen werden!

Lesen Sie sich bitte die beiliegende Installations- und Betriebsanleitung durch. Es ist wichtig, dass die Installation entsprechend den Werksangaben erfolgt, damit Ihr Produkt mit maximalem Wirkungsgrad arbeiten kann.

Follett LLC ist nicht für Folgeschäden, Ausgaben, Gebühren für Anschluss oder Abschaltung oder Verluste aufgrund eines Defekts der Maschine haftbar.

Vollständige Garantieinformationen finden Sie auf unserer Website unter www.follettice.com/productwarranties.

Garantieregistrering und Produktbeurteilung sind wichtig, damit wir einen Überblick über unsere Produkte behalten und ihre Effizienz bewerten können. Wir möchten Sie bitten, Garantien für Follett-Produkte auf unserer Website www.follettice.com/support zu registrieren und den Punkt „Garantieregistrering und Produktbeurteilung“ zu wählen. Es ist ganz einfach. Nehmen Sie sich bitte einen Moment Zeit, um die Registrierung heute vorzunehmen. Auf dem Formular ist auch Platz für Kommentare und Feedback vorhanden. Teilen Sie uns bitte Ihre Erfahrungen mit unseren Produkten mit, damit wir sie für unsere fortlaufenden Produktverbesserungen verwenden können.

Wir sind stolz darauf, dass wir besondere Produkte herstellen, und wir bemühen uns, unsere Produkte mit besonderem Kundendienst zu unterstützen. Lassen Sie uns bitte wissen, was wir noch für Sie tun können. Wir werden Ihre Fragen gerne beantworten.

Registrazione della garanzia e valutazione dell'attrezzatura

Grazie per aver acquistato un dispositivo Follett®. Ci auguriamo che il nostro prodotto soddisfi o superi le Sue aspettative, in quanto il nostro obiettivo è quello di offrire prodotti e servizi di alta qualità che soddisfino pienamente le vostre esigenze!

La preghiamo di leggere attentamente il manuale per l'installazione e per l'uso allegato. È infatti importante che l'installazione sia effettuata secondo le specifiche di fabbrica in modo tale che il dispositivo operi con la massima efficienza.

La Follett LLC non si assume alcuna responsabilità per danni conseguenti, spese, costi di collegamento o scollegamento o eventuali perdite dovute ad un difetto della macchina.

Per visualizzare i dettagli completi relativi alla garanzia, recarsi alla pagina www.follettice.com/productwarranties.

La registrazione della garanzia e la valutazione dell'attrezzatura sono importanti per aiutarci a tenere traccia dei nostri dispositivi e a registrare le prestazioni della macchina. Le chiediamo dunque di registrare le garanzie relative al dispositivo Follett sul nostro sito Web alla pagina www.follettice.com/support scegliendo Registrazione della garanzia e Valutazione dell'attrezzatura. Farlo è semplice; dedichi pochi minuti a registrare il prodotto oggi stesso. Sul modulo è inoltre previsto uno spazio in cui potrà fornirci i Suoi commenti e il Suo riscontro. Ci faccia sapere della Sua esperienza in modo che possiamo farne tesoro per il nostro continuo miglioramento.

Siamo orgogliosi di produrre macchinari di ottima qualità e lavoriamo sodo per offrire un servizio di assistenza clienti e tecnico di qualità altrettanto elevata. Ci faccia sapere come possiamo esserle di aiuto. Saremo lieti di rispondere a tutte le Sue domande.

Registo da garantia e avaliação do equipamento

Obrigado por ter adquirido equipamento Follett®. Fazemos votos de que o nosso equipamento cumpra ou exceda as suas expectativas, dado que temos por objetivo fornecer produtos e serviços de elevado valor que mereçam a sua total satisfação!

Pedimos-lhe que leia o manual de instalação e operações em anexo. É importante que a instalação seja levada a cabo de acordo com as especificações da fábrica, para que o seu equipamento funcione com a eficiência máxima.

A Follett LLC não assume a responsabilidade por quaisquer prejuízos indiretos, despesas, custos de ligação ou desligação ou quaisquer outras perdas decorrentes de um defeito na máquina.

Para consultar os dados da garantia, visite o nosso website www.follettice.com/productwarranties.

O registo da garantia e a avaliação do equipamento são importantes para nos ajudar a estar a par do nosso equipamento e registar o desempenho da máquina. Pedimos-lhe que registe as garantias de equipamento Follett no nosso website www.follettice.com/support, em “Warranty Registration and Equipment Evaluation”. É muito simples; tire uns minutos para fazer o registo hoje mesmo. O formulário inclui também espaço para os seus comentários e feedback. Conte-nos a sua experiência para que possamos usá-la nos nossos esforços contínuos de melhoria.

Temos muito orgulho em produzir equipamento excepcional e empenhamo-nos em proporcionar um apoio técnico e um apoio ao cliente igualmente excecionais. Diga-nos o que mais podemos fazer para o ajudar. Teremos todo o prazer em responder às suas perguntas.

Registrering af garanti og evaluering af udstyr

Tak for dit køb af Follett®-udstyr. Forhåbentlig synes du, at vores udstyr lever op til eller overstiger dine forventninger, for vores målsætning er at levere produkter og serviceydelser af høj kvalitet, som du er fuldstændig tilfreds med!

Gennemlæs venligst den vedlagte installations- og driftsmanual. Det er vigtigt at installationen udføres i henhold til fabriksspecifikationerne, så dit udstyr kan fungere med maksimal effektivitet.

Follett LLC hæfter ikke for følgeskader, udgifter, tilslutnings- eller frakoblingsomkostninger eller nogen form for tab, der skyldes en maskindefekt.

Du kan læse de fulde oplysninger om garantien på vores website www.follettice.com/productwarranties.

Registrering af garantien og evaluering af udstyret er vigtigt for at hjælpe os med at følge op på vores udstyr og registrere maskinens ydelse. Vi beder dig registrere garantier på Follett-udstyr på vores website www.follettice.com/support og vælge Warranty Registration and Equipment Evaluation (Registrering af garanti og evaluering af udstyr). Det er nemt at gøre, så vi beder dig bruge et øjeblik på at registrere dig i dag. Formularen har også plads til, at du kan give os kommentarer og feedback. Fortæl os om dine erfaringer, så vi kan bruge dem i vores fortsatte bestræbelser på at forbedre os.

Vi sætter en ære i at fremstille udstyr i særklasse og arbejder hårdt på at kunne bakke udstyret op med fremragende kundeservice og teknisk support. Fortæl os, hvad vi ellers kan gøre for at hjælpe dig. Vi svarer gerne på dine spørgsmål.

Registratie van garanties en beoordeling van apparatuur

Gefeliciteerd met uw aankoop van Follett®-apparatuur. We hopen dat onze apparatuur uw verwachtingen invult of zelfs overstijgt, omdat we ernaar streven om hoogwaardige producten en diensten te leveren die u uitermate tevreden stellen!

Lees de bijgevoegde installatie- en bedieningshandleiding zorgvuldig door. Het is belangrijk dat de installatie uitgevoerd wordt volgens de fabrieksspecificaties, zodat uw apparatuur zo efficiënt mogelijk werkt.

Follett LLC is niet aansprakelijk voor enige gevolgschade, uitgaven, montage- of demontagekosten of enige door een defect van de machine geleden verliezen.

Bezoek onze website www.follettice.com/productwarranties voor alle garantiegegevens.

De registratie van garanties en de beoordeling van apparatuur is belangrijk voor ons om onze apparatuur te helpen traceren en de prestaties van de machine te registreren. We verzoeken u dan ook om garanties van Follett-uitrusting te registreren op onze website www.follettice.com/support en om "Warranty Registration" (Registratie van garanties) en "Equipment Evaluation" (Beoordeling van apparatuur) te kiezen. Gelieve hier even tijd voor vrij te maken. Het is namelijk zeer eenvoudig. Er is op het formulier ook plaats om opmerkingen en feedback te geven. Breng ons gerust op de hoogte over uw ervaring met onze apparatuur, zodat we ons kunnen blijven verbeteren.

We zijn trots op onze productie van uitstekende apparatuur en werken hard om dit bij te staan door een voortreffelijke klantendienst en technische ondersteuning. Aarzel echter niet om enige andere bijstand te vragen. We zullen uw vragen met plezier beantwoorden.

Garantiregistrering och utvärdering av utrustning

Tack för att du köpt utrustning från Follett®. Vi hoppas att du ska tycka att den uppfyller eller överträffar dina förväntningar, då vårt mål är att leverera produkter och tjänster av högt värde som gör dig helt nöjd!

Studera medföljande installations- och bruksanvisning. Det är viktigt att installationen genomförs enligt fabrikens anvisningar så att din utrustning arbetar med högsta effektivitet.

Follett LLC ansvarar inte för följdskador, kostnader, avgifter eller förluster som orsakats av fel på maskinen.

Fullständiga garantivillkor finns på vår hemsida www.follettice.com/productwarranties.

Garantiregistrering och utvärdering av utrustning är viktig för oss så att vi kan följa upp vår utrustning och dess funktion. Vi vill att du registrerar Folletts utrustningsgaranti på vår hemsida www.follettice.com/support, där du väljer Garantiregistrering och produktutvärdering. Det är enkelt att göra, så ta dig tid en minut och registrera dig idag. Det finns också utrymme på blanketten för kommentarer och synpunkter. Berätta för oss vad du tycker så att vi kan använda det i våra ansträngningar att alltid bli bättre.

Vi är stolta över att producera överlägsen utrustning och vi arbetar hårt med att stötta den med överlägset kundansvar och tekniskt stöd. Tala om för oss vad vi kan göra mer för att hjälpa dig. Vi svarar gärna på dina frågor.

Warranty Registration and Equipment Evaluation

Thank you for purchasing Follett® equipment. We hope you find that our equipment meets or exceeds your expectations, as our goal is to deliver high value products and services that earn your complete satisfaction!

Please review the enclosed installation and operations manual. It is important that the installation be performed to factory specifications, so your equipment operates to its maximum efficiency.

Follett LLC will not be liable for any consequential damages, expenses, connecting or disconnecting charges or any losses resulting from a defect of the machine.

For full warranty details, visit our website www.follettice.com/productwarranties.

Warranty registration and equipment evaluation is important to help us keep track of our equipment and to record the machine's performance. We request that you register Follett equipment warranties on our website www.follettice.com/support and choose Warranty Registration and Equipment Evaluation. It's simple to do; please take a moment to register today. There is also space on the form to provide us with comments and feedback. Please let us know about your experience so we can capture it for our continuous improvement efforts.

We pride ourselves on producing outstanding equipment and we work hard to back it up with outstanding customer and technical support. Please let us know what else we can do to assist you. We would be happy to answer your questions.

SafeCLEAN, SensorSAFE, Maestro Plus, Symphony Plus, Quiet Night and Sani-Sponge are trademarks of Follett LLC. Follett and RIDE are registered trademarks of Follett LLC, registered in US.