

Horizon Elite™ 1412 Ice Machine Installation Instructions for Remote Condensing Unit

F1412R

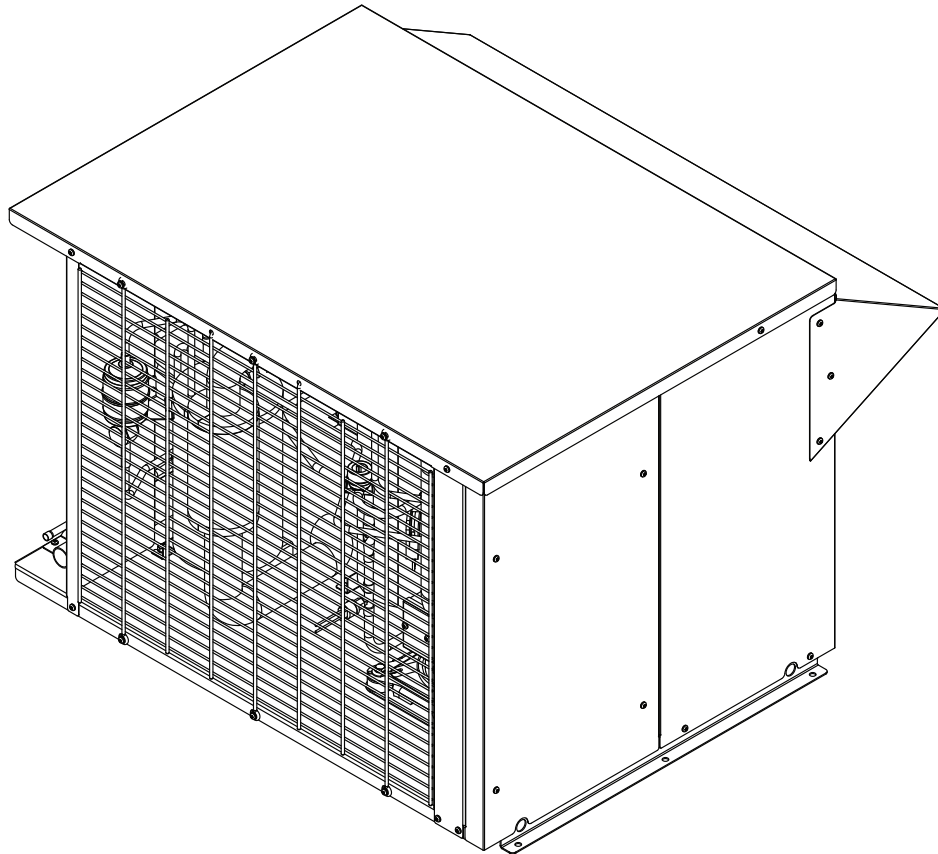
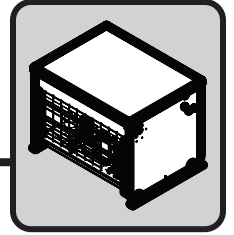

	Horizon Elite F1412CU series
W1 Width	39.6" (100.6 cm)
D1 Depth	28.2" (71.6 cm)
H1 Height	26.0" (66.0 cm)
Electrical	three phase – 208-230/60/3 (Emerson/Copeland)
Minimum circuit ampacity	three phase – 12A
Maximum overcurrent protection	three phase – 20A
Outdoor condensing unit operating limits (air temperature)	min –20 F (–29 C) max 120 F (49 C)
Maximum refrigerant line run length	100' (30,5 m)
Maximum line rise above evaporator	35' (10,7 m)
Evaporator mounting above condenser	15' (4,6 m)
Maximum refrigeration line drop without oil trap	15' (4,6 m)
Refrigerant charge	8 lb
Approximate ship weight	three phase – 265 lbs (120.2 kg)
Approximate net weight	three phase – 230 lbs (104.3 kg)

Prior to installation, carefully unpack and inspect the contents of your condensing unit!

Site preparation

1

To ensure proper performance, ease of service and warranty coverage, it is critical that you follow the requirements detailed in this manual. If you cannot meet these requirements or have questions, call our technical service group at 877.612.5086 for installation support.

1.1 Condenser Unit Clearances

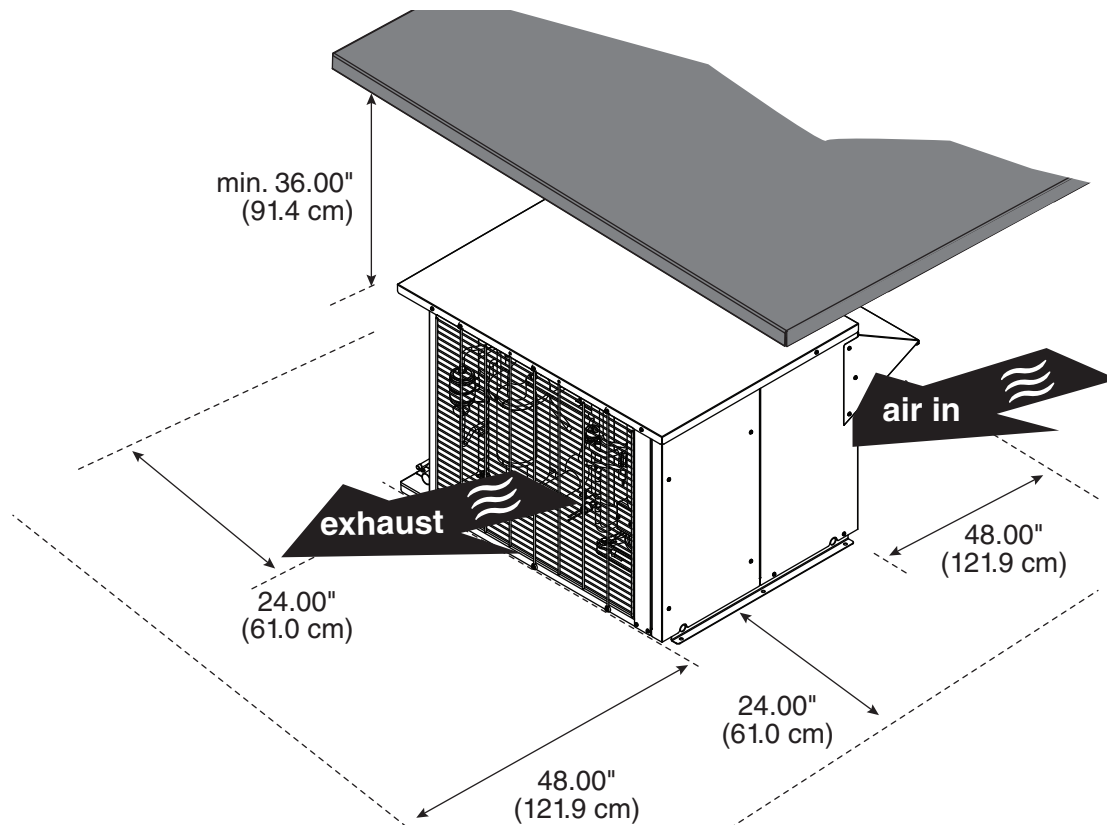

- Position condenser unit as shown.

Required clearances:

- Minimum 48" (121.9 cm) front and back
- Minimum 24" (61.0 cm) left and right
- Minimum 36" (91.4 cm) above

1.2

Condenser installation specifications

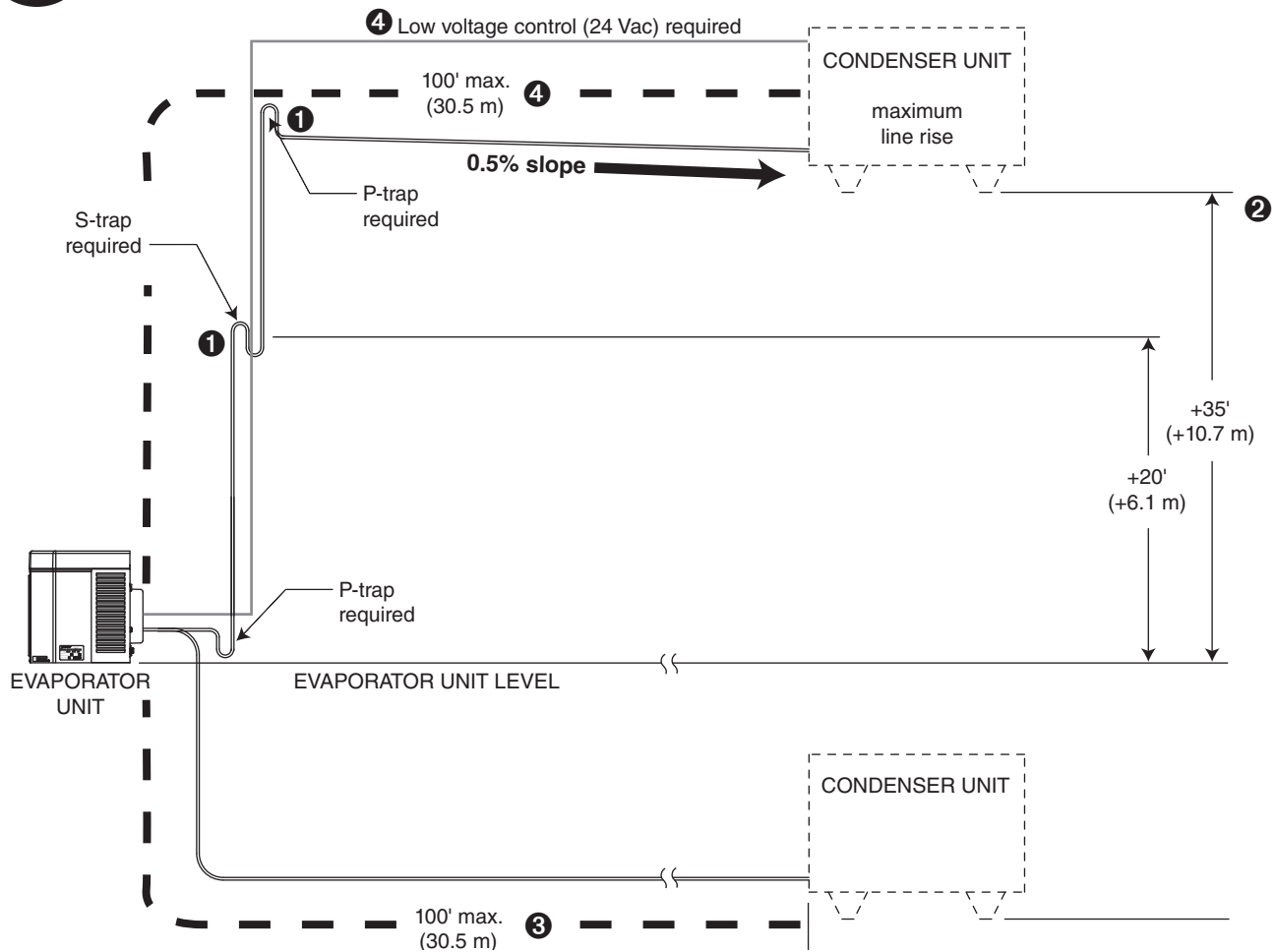

Site layout:

- Outdoor ambient temperature range: -20 F to 120 F (-29 C to 49 C)
- Installation with condenser unit elevations above $20'$ (6.1 m) require an S-trap at the midpoint of the rise and a P-trap at the top of the rise ①
- Maximum line rise must not exceed $35'$ (10.7 m) ②
- Maximum line set length must not exceed $100'$ (30.5 m) ③
- Low voltage control (24 Vac signal wire) must be connected ④

2.1 Install condensing unit

- Level unit
- Securely attach base of unit using holes found in base plate

2.2 Rack system

- F1412CU not compatible with rack system. Consult Technical Service.

2.3 Electrical requirements

 **CAUTION**

- Electrical disconnects required
- Electrical disconnects installed in accordance with NEC and local electrical codes

	Horizon Elite F1412CU
Minimum circuit ampacity	three phase – 12A
Maximum overcurrent protection	three phase – 20A
Outdoor condensing unit operating limits (air temperature)	min –20 F (–29 C) max 120 F (49 C)

2.3

Electrical schematic

F1x12CU

3-PHASE, 208-230 VAC

OUTDOOR CONDENSING UNIT

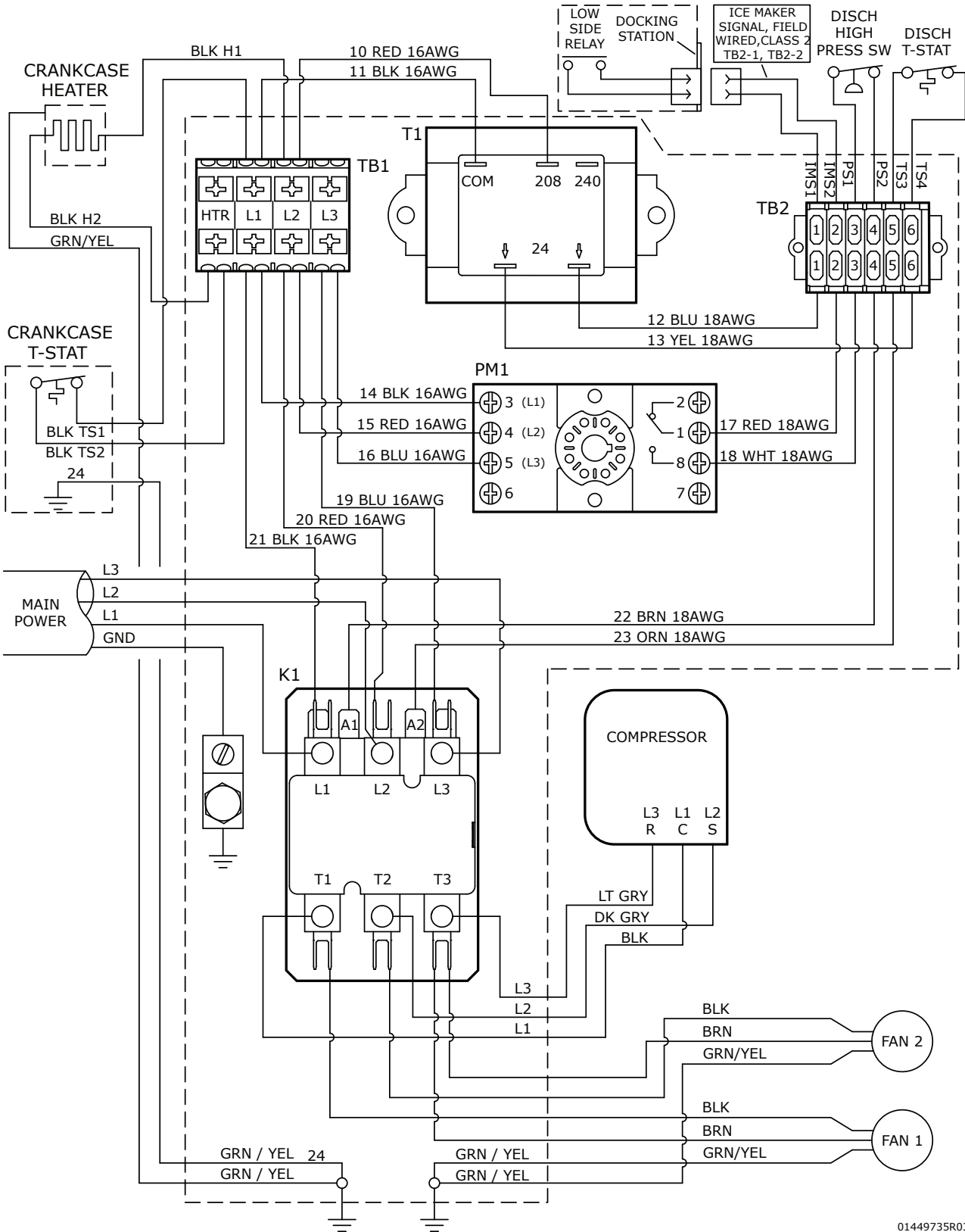

01449735R03

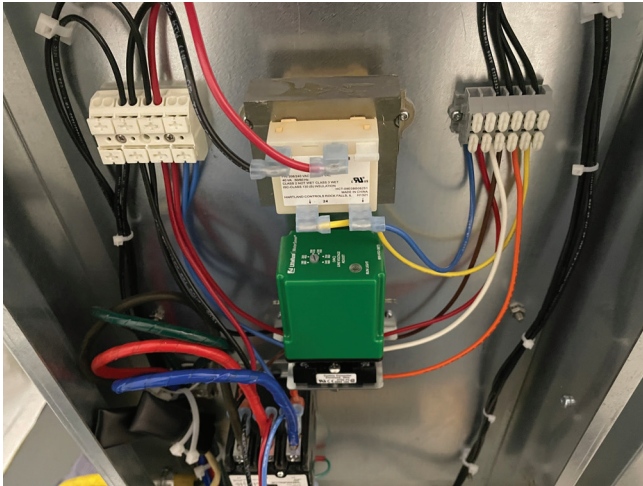

2.4

Phase monitor adjustments (if necessary)



1. The phase monitor is preset to 208 Vac from the factory.
2. If building voltage is less than 208 Vac, consult technical service.
3. See below chart for phase monitor diagnostics.

PLEASE NOTE THAT ANY TIME POWER IS APPLIED TO THE CONDENSING UNIT, OR THE UNIT COMES OUT OF A FAULT STATE, IT WILL TAKE APPROXIMATELY 200 SECONDS FOR THE UNIT TO POWER ON.

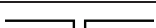
INDICATOR LIGHT	STATUS
GREEN	RUN
 GREEN	RESTART DELAY
 RED	REVERSE PHASE
 RED	UNBALANCE / SINGLE PHASE (SEE EXAMPLE BELOW)
RED	LOW VOLTAGE
 RED	HIGH VOLTAGE (201A-9 ONLY)

2.5

Condensing unit refrigeration line-set connection point

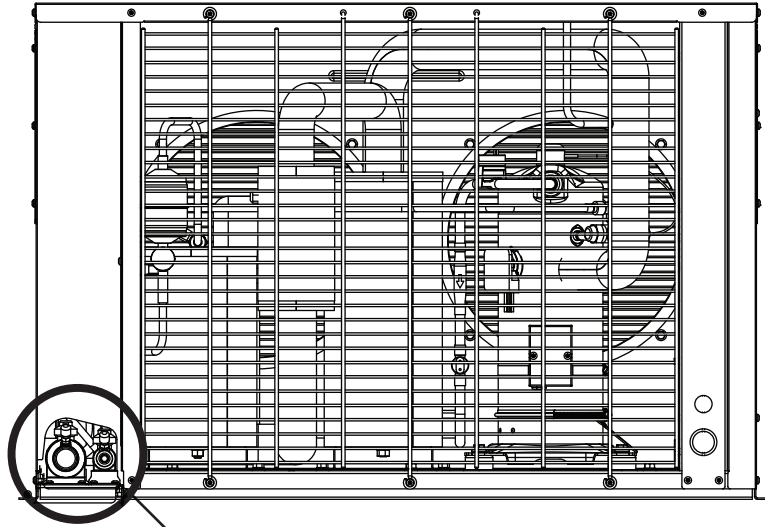

1412:
7/8" OD suction line
3/8" OD liquid line

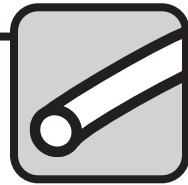

3.1 Refrigeration line installation: 7/8" OD suction line / 3/8" OD liquid line



CAUTION

- The installer of the refrigeration line set must be USA Government Environmental Protection Agency (EPA) certified in proper refrigeration handling and service procedures
- A qualified person must perform all roof or wall penetration
- Do not form unwanted traps in refrigeration lines. A service loop is not considered an oil trap.
- Never coil excess refrigeration tubing
- The compressor oil rapidly absorbs moisture. Minimize the exposure of the refrigeration system by not releasing the condenser unit or evaporator unit holding charge until all line connections are finished and the system is ready for evacuation.



WARNING

- **This unit contains a full charge of R449A.**

1. Make and connect line set run from the condensing unit to the evaporator unit with all specifications found in the installation specifications section. Do not overheat shut off valves on the condenser unit or evaporator unit.

Note: Insulate entire suction line (not the liquid line) including shut off valves to prevent condensation.

2. Leak check field joints via the evaporator unit service valves.
3. Evacuate line set via the evaporator unit service valves.

R449A Ice Machine Charge Specifications	
Line Run	Total Charge 1412R three phase
0 - 100' (0 - 30.5 m)	8 lb (3.63 kg)
100' + (30.5 m+)	Consult Technical Service

Note: Condensing unit shipped fully charged with 8 lb R449A.

5. Ensure all valves are open on condensing unit and ice machine.
9. Turn on power to condensing unit and evaporator unit.

4.1 Low voltage control (24 Vac)

The low voltage control (24 Vac signal wire) must be run and connected at the back of the ice machine and to the condensing unit. Route low voltage wire through the upper knockout at the condensing unit and secure with appropriate connector per NEC.

Follett suggests the following wire for the ice machine signal wire (2 conductor, 18 gauge thermostat wire), but be sure to follow NEC guidelines:

Southwire: 553020507, Johnston Supply: G80-220, United refrigeration: UL1825

Ice Machine

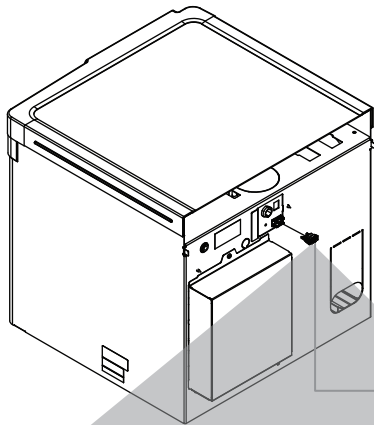

Outdoor Condensing Unit

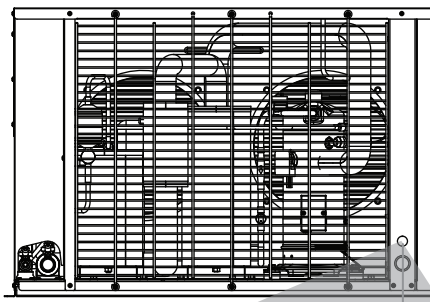

24 Vac signal wire

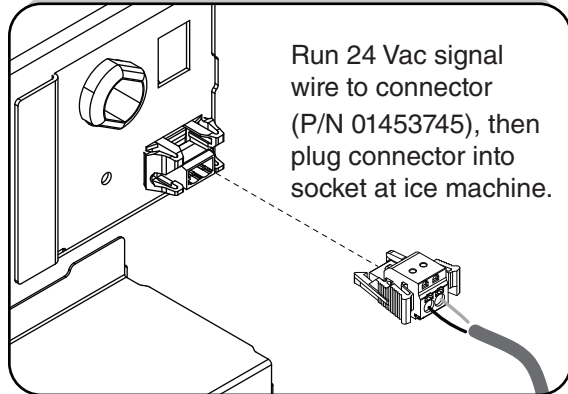

Run 24 Vac signal wire to connector (P/N 01453745), then plug connector into socket at ice machine.

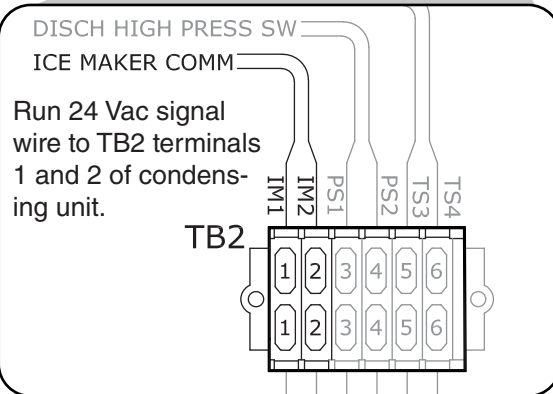

DISCH HIGH PRESS SW
ICE MAKER COMM

Run 24 Vac signal wire to TB2 terminals 1 and 2 of condensing unit.

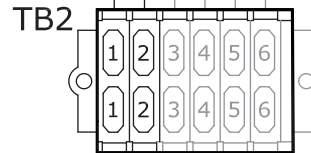

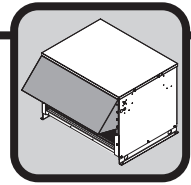

5.1 Install hail hood

1. Hail hood is shipped taped to the unit.
2. Install hail hood using enclosed self-tapping screws (attached to underside of hail hood).

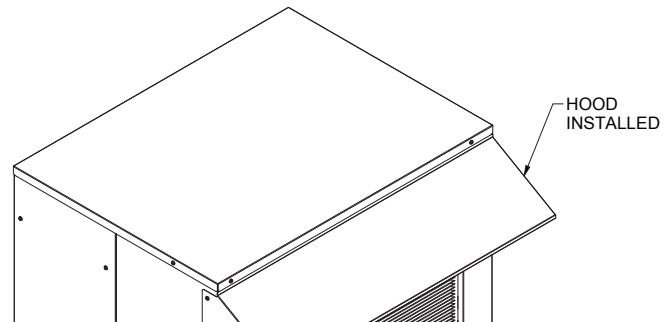
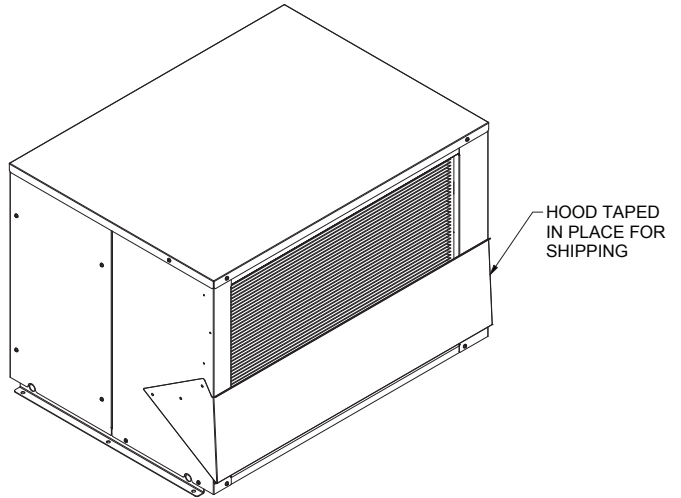

NOTICE

Ice machine MUST be cleaned and sanitized prior to operation!

Consult Operation and Service Manual provided with ice machine for cleaning and sanitizing instructions.



6.1 Verify operation

- Turn dispenser power ON if applicable
- Three-phase scroll compressors will rotate in either direction, depending on power phasing. Prolonged operation in reverse will result in insufficient lubrication. Determine the proper rotation at start up by observing that the suction pressure drops and discharge pressure rises.
- Put a piece of ice on bin thermostat or hold a cup under the shuttle actuator on the bin/dispenser to verify that the evaporator unit shuts OFF.
- After shut off, restart the ice machine

Note: After unit shuts off, pressures will equalize.

Horizon Condenser Unit Compressor Amperage - Three Phase

Ice Machine Model Number	Condensing Unit	Running amps (+/- 10%)
F1412R	ZF06KAE-TF5-118 (Copeland)	RLA 6.3 Max continuous current: 11.6A

Horizon Elite, Ice Manager, and Vision are trademarks of Follett Products, LLC.
Chewblet, RIDE and Follett are registered trademarks of Follett Products, LLC, registered in US.