

Horizon Elite™ Ice Machine Models with RIDE® Technology Installation Instructions for Vision™

D1010R, D1410R, D1412R, D1810R, D2110R

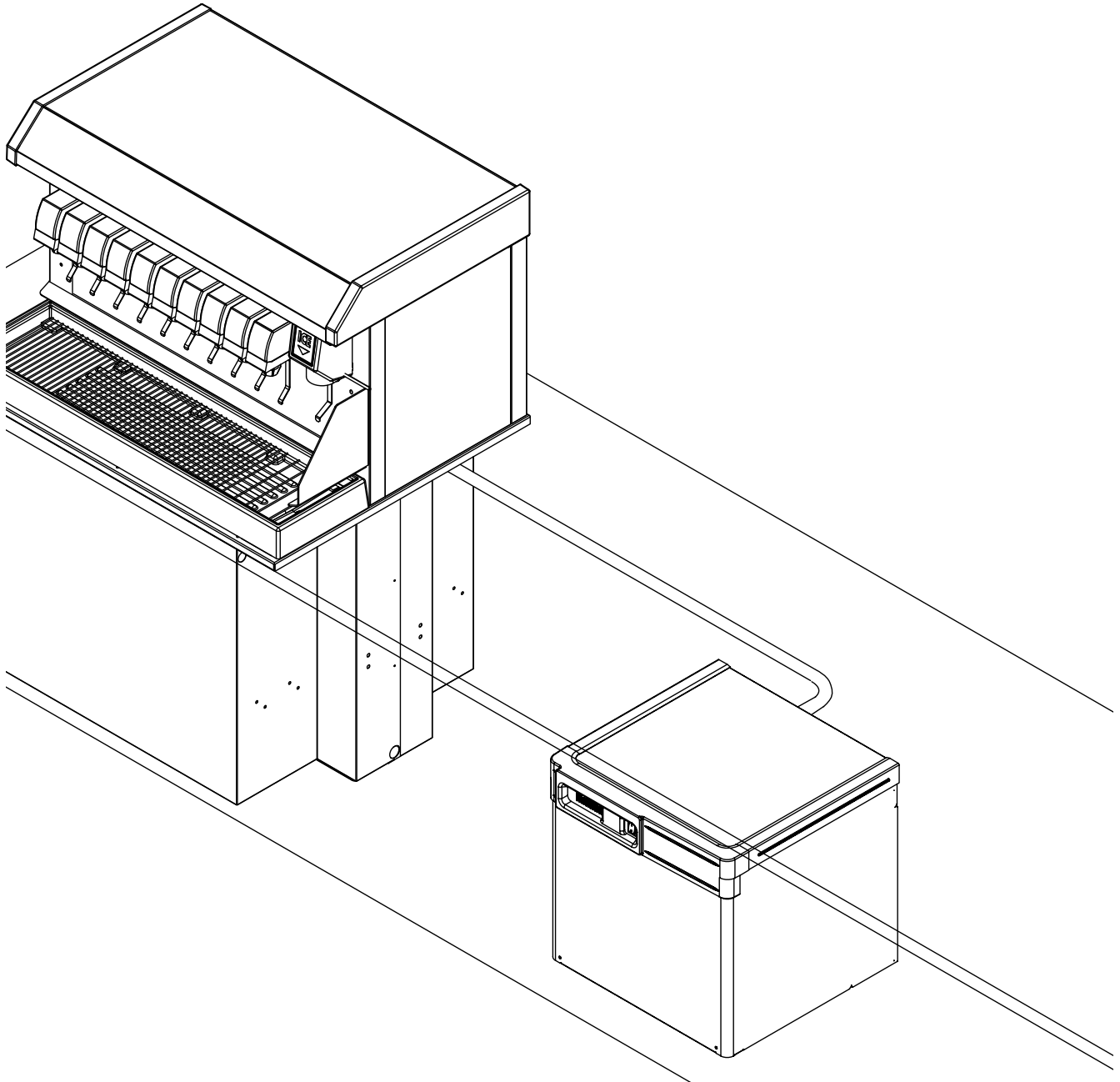
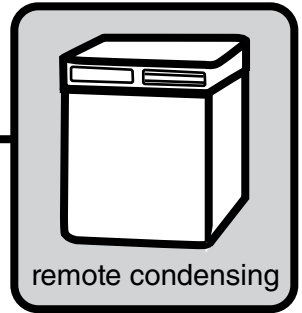

801 Church Lane • Easton, PA 18040, USA
Toll free (877) 612-5086 • +1 (610) 252-7301
www.follettice.com

01565100R00

 **CAUTION!**

- This appliance should be connected by a qualified person in accordance with applicable codes.
- If the supply cord is damaged, it must be replaced by the manufacturer, its service agent or similarly qualified persons in order to avoid a hazard.
- Connect to potable water supply only.
- This appliance can be used by children aged 8 years and above and persons with reduced physical, sensory, or mental capabilities, or lack of experience and knowledge if they have been given supervision or instruction concerning use of the appliance in a safe way and understand the hazards involved. Children should be supervised to ensure that they do not play with the appliance.
- This appliance is intended to be used for household and similar applications such as staff kitchen areas in shops, offices and other working environments; farm houses and by clients in hotels, motels and other residential type environments; bed and breakfast type environments; catering and similar non-retail applications.
- **WARNING!** To avoid a hazard due to instability of the appliance, it must be fixed in accordance with the instructions.

Read and complete the following 8 installation steps

1 **Unpack** _____



2 **Site preparation** _____



3 **Dispenser preparation** _____



4 **Docking assembly** _____

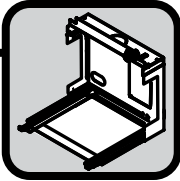

5 **Ice transport tube** _____



6 **External connection** _____



7 **Internal connection** _____

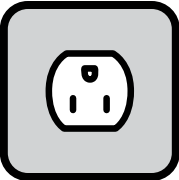

8 **Front cover** _____

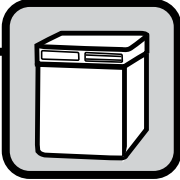

Carefully unpack and inspect the contents of your Follett ice machine.

Unpack

1

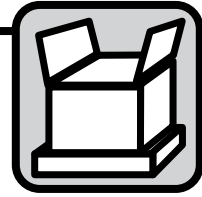

1.1 Unpack ice machine

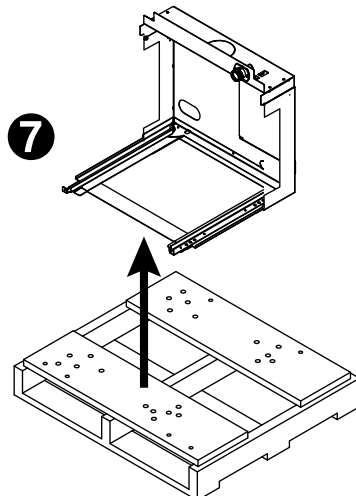
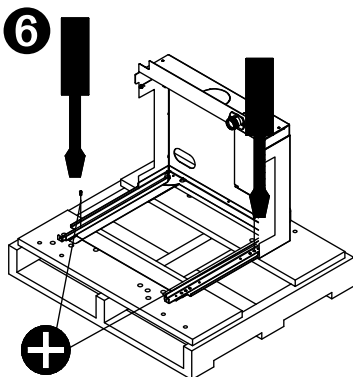
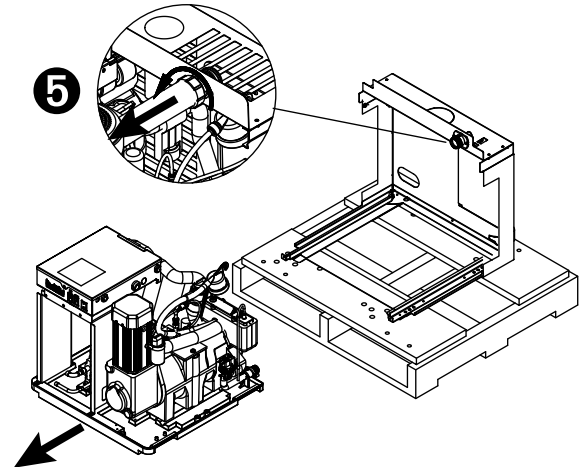
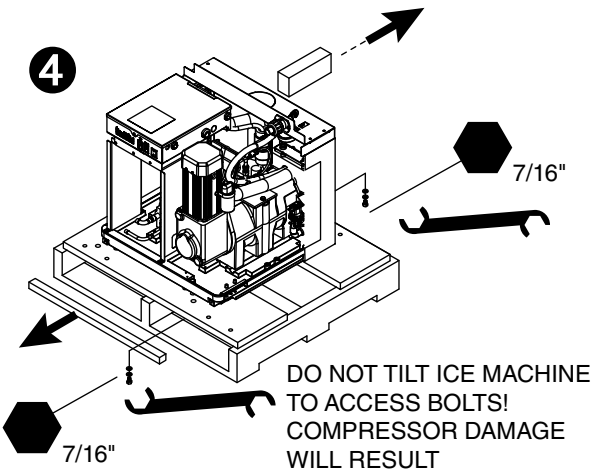
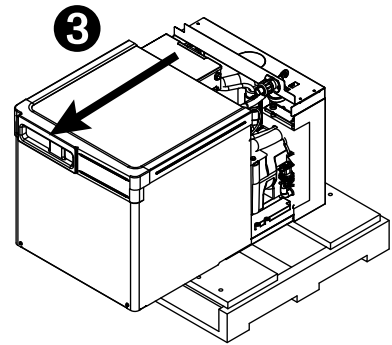
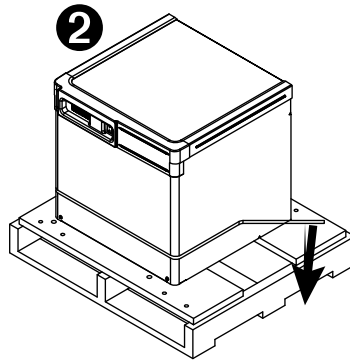
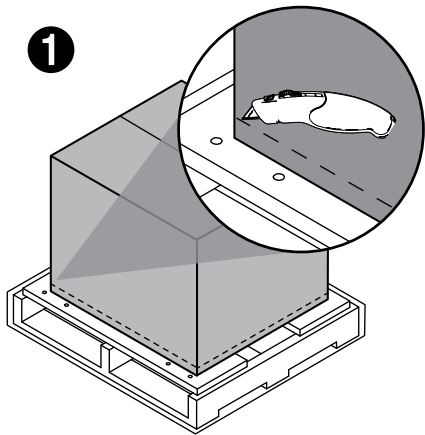

Prepare the installation site.

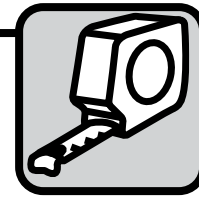

Provide drainage, water supply and electrical power to within 6 feet (2 m) of ice machine in accordance with local and national codes. Outdoor installation of low side is not recommended and will void warranty.

2.1 Installation site requirements

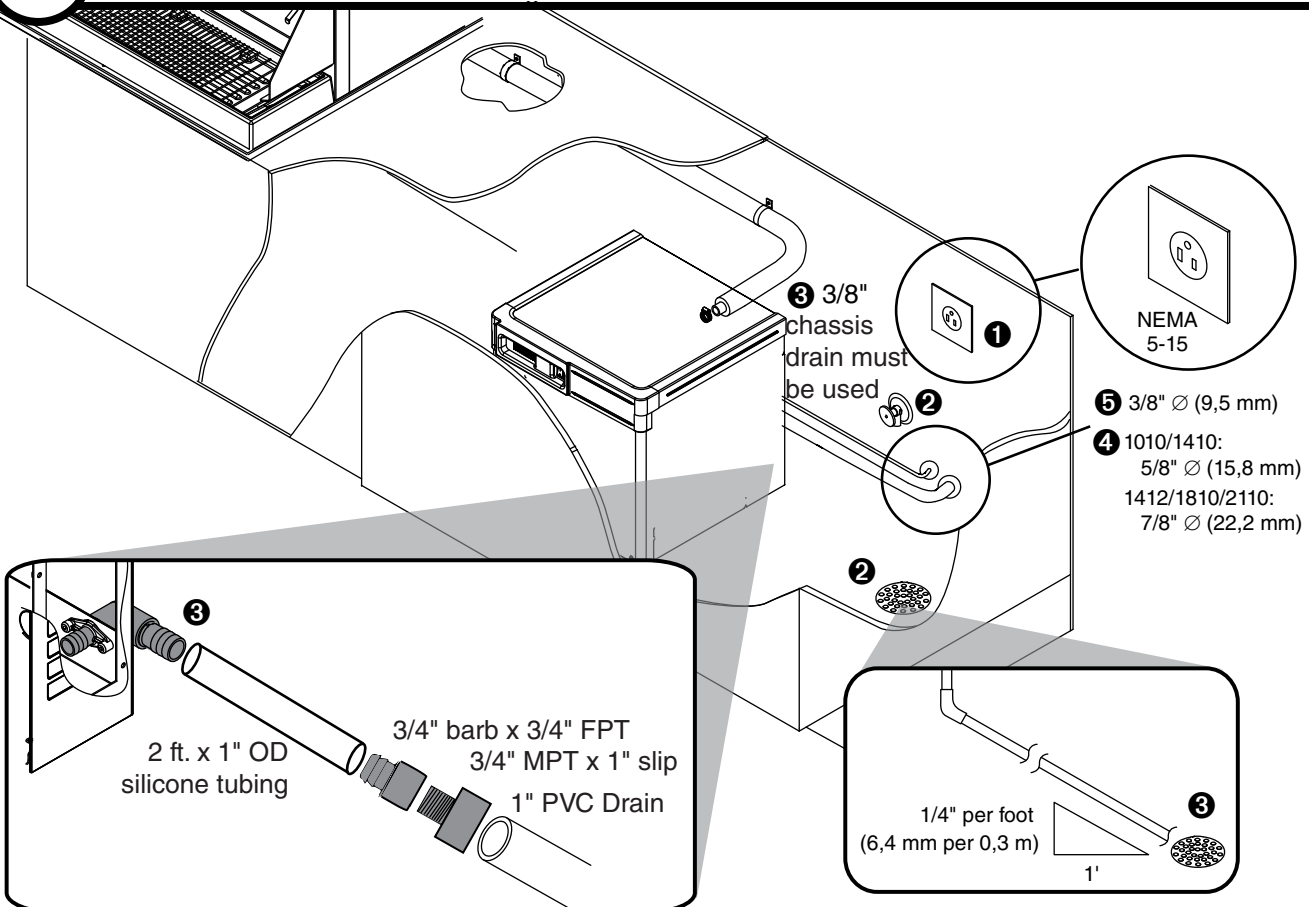

Electrical ①

- 120/60/1–5 amps

Potable water supply ② (3/8" push-in connection, 3/8" OD tubing required)

- 10–70 psi (69–483 kpa)
- 45–90 F (7–32 C)
- This equipment is to be installed with adequate backflow protection to comply with applicable federal, state, and local codes

Drains: ③ 3/4" Barb for silicone drain, 3/8" push-to-connect for chassis drain

- Minimum 8" radius on silicone drain line. Drain line from the ice machine must have at least 1/4" per foot pitch (6,4 mm/0,3 m).

Refrigeration lines ④

- 1010/1410: 5/8" Ø (15,8 mm) diameter suction line (insulated) ④
- 1412/1810/2110: 7/8" Ø (22,2 mm) diameter suction line (insulated) ④
- 3/8" Ø (9,5 mm) liquid line ⑤

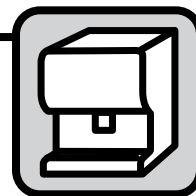

3.1 Bin Signal Installation

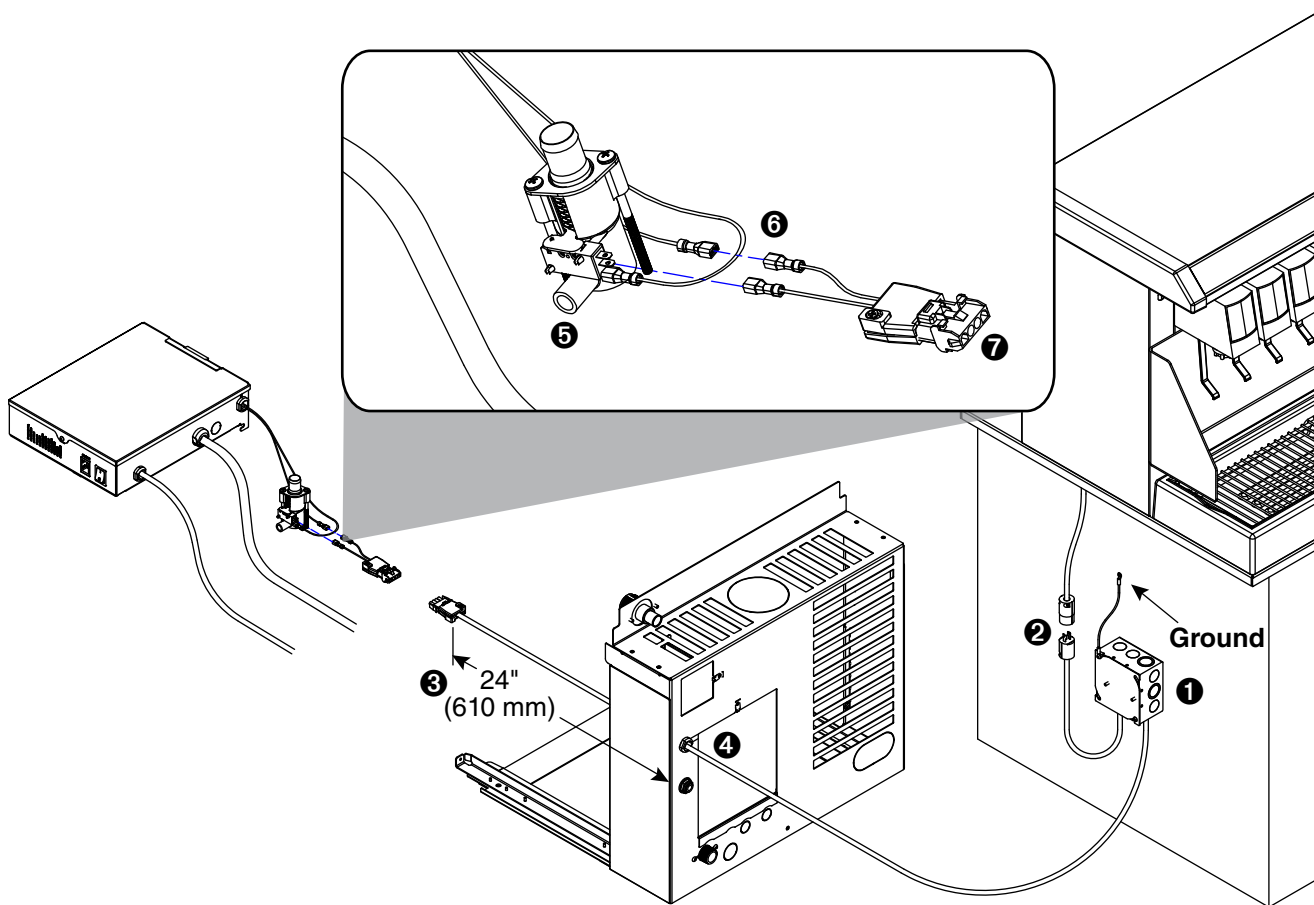

- Mount the electrical box to the side of the Vision dispenser ① to establish a ground connection. **Note:** If a 4 x 4 box is mounted to a non-grounded surface, connect ground wire at an appropriate ground.
- Connect the bin signal plug on the electrical box to the bin signal cord on the bin ②
- Insert 24" (70 cm) of the long bin signal cable ③ into the hole in the back of the docking station ④ and secure in place with strain relief provided.
- After sliding the ice machine module into the docking station, disconnect one wire from shuttle switch and replace with wire from adapter plug. ⑤
- Connect wire removed from shuttle switch to male connector on adapter plug wire. ⑥
- Complete normal installation procedure for the ice machine using the installation manual that shipped with the ice machine.
- Connect adapter plug into bin signal plug. ⑦

Install the docking assembly.



BEFORE PROCEEDING

Prior to installing the docking assembly, ensure that the drain fitting is oriented (right or left) correctly for your installation. An optional straight drain fitting is also supplied. You may need to remove the back panel of the docking assembly in order to re-orient or change the drain fitting. Replace back panel prior to mounting the docking assembly.

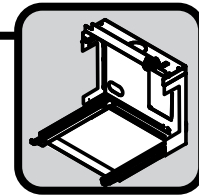

Wall bracket accessory

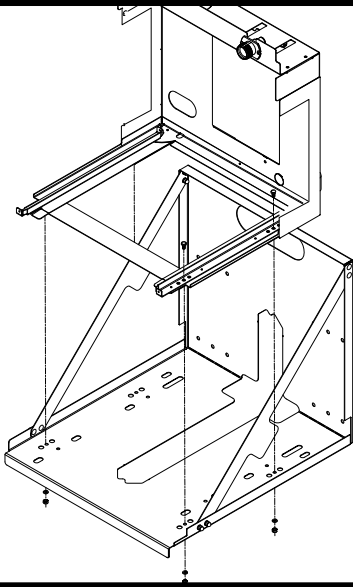

- Mount docking assembly to wall bracket accessory

Machine stand accessory

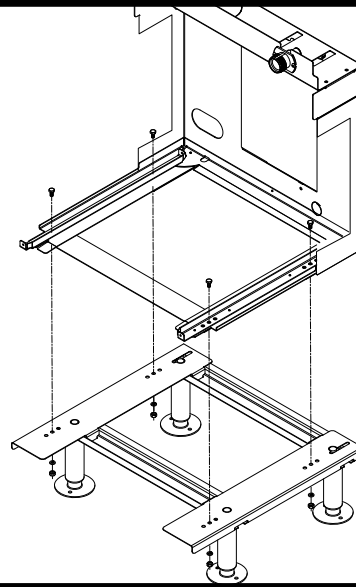

- Mount docking assembly to machine stand accessory

4.1 Docking assembly

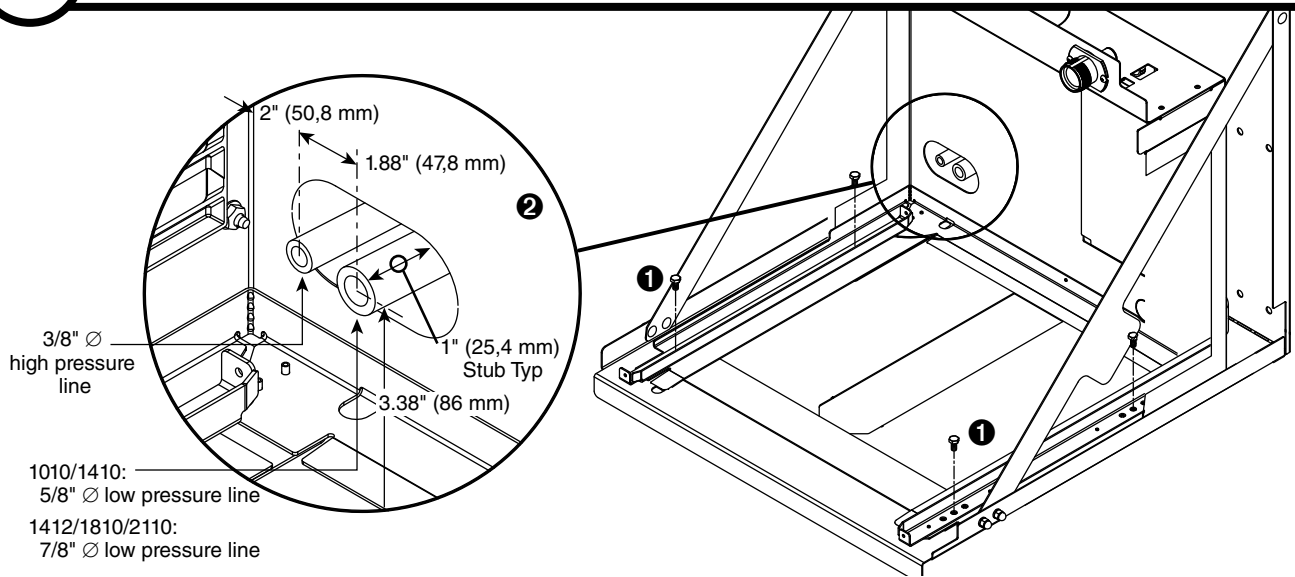

- Mount docking assembly ①
- "Rough-in" the refrigerant piping ②

4.2 Undercounter installation requirements

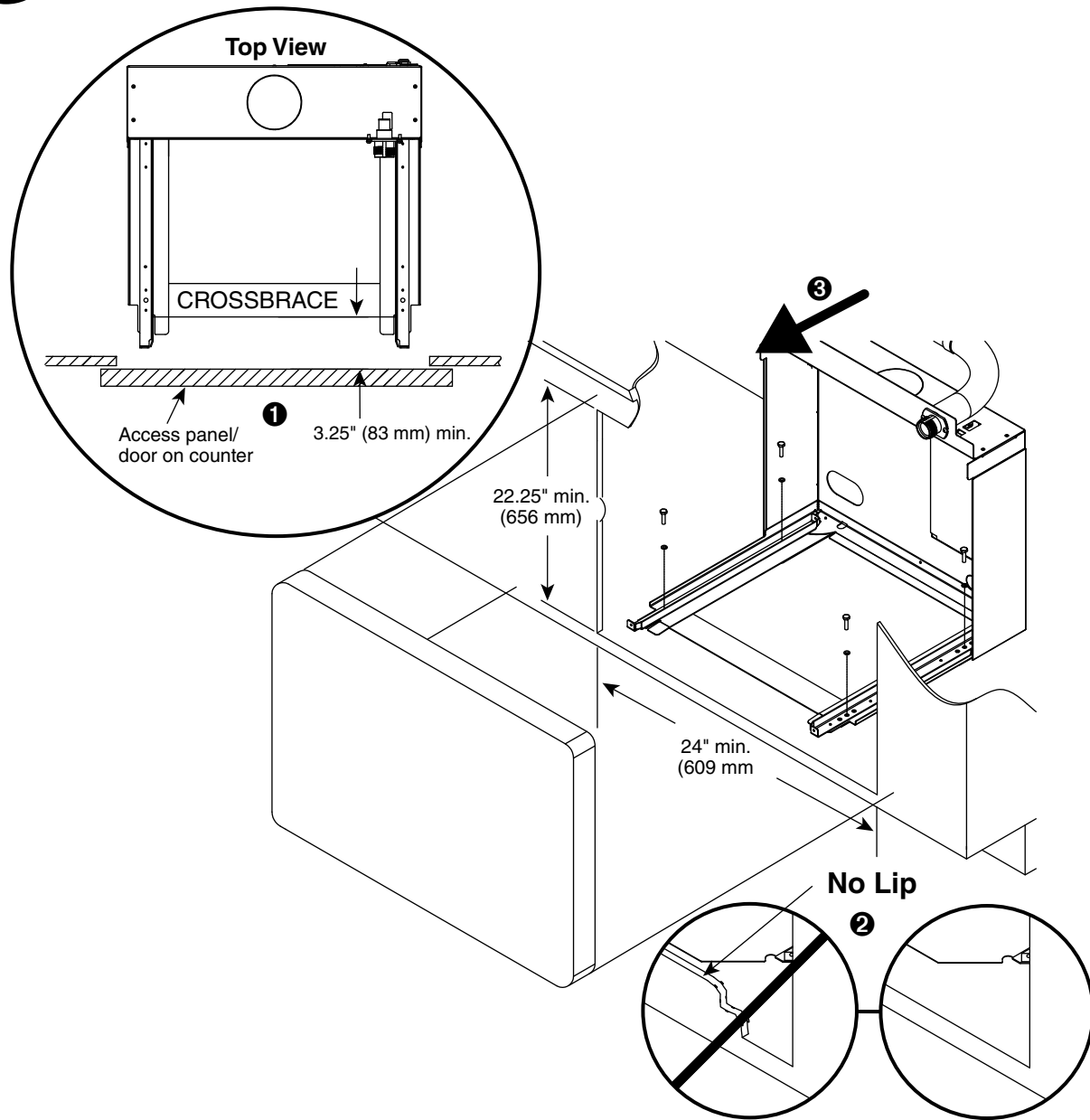

DOCKING STATION

- Prior to installing the docking assembly, ensure that the drain fitting is oriented (right or left) correctly for your installation. An optional straight drain fitting is also supplied. You may need to remove the back panel of the docking assembly in order to re-orient or change the drain fitting. Replace back panel prior to mounting the docking assembly.
- Position and screw docking assembly to the bottom of counter inside of access panel/door min. of 3.25" (83 mm) from the front edge of the cross brace ①
- The mounting surface for the docking assembly must be solid. Do not mount directly onto runners or channels.
- There must be no lip or edge that would hinder the ice machine from sliding in or out of the docking station ②
- Ice machine must be installed facing forward as shown for service accessibility ③

Install the ice transport tube.

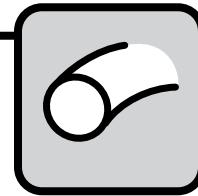

5.1 Dispenser ice transport tube installation

Ice tube retainer bracket

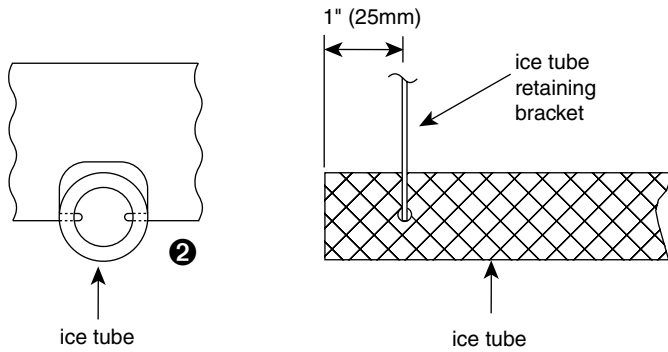

Front View VU155

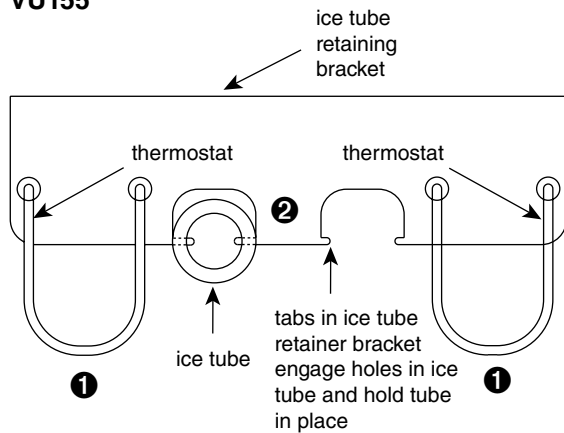

Front View VU300

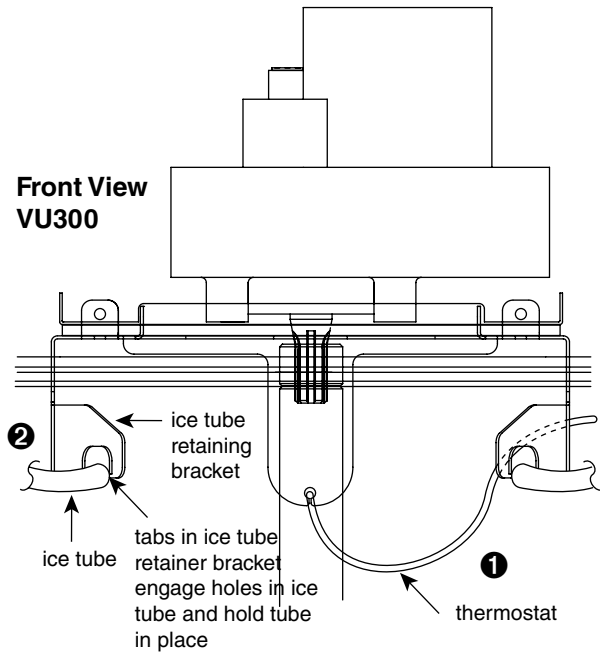

- One end of the ice transport tube has 1/8" holes drilled into it; this end connects on the inside of the Vision dispenser.
- Push one end of ice transport tube(s) through hole(s) provided in side of dispenser
- Route tube into ice tube bracket inside dispenser and engage bracket tabs in holes located in end of ice transport tube(s) ①
- Verify bin thermostat capillary tube is mounted correctly ②

5.2 Ice transport tube installation.

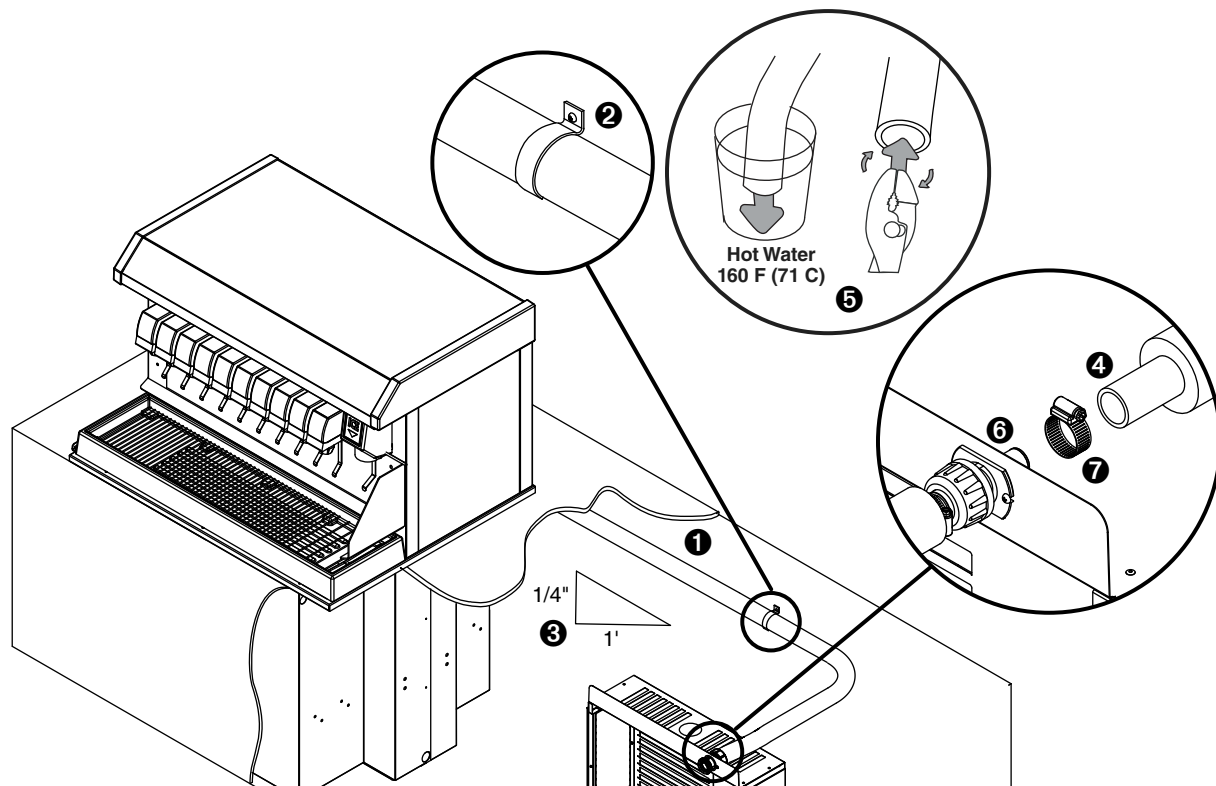

Ice transport tube tips

- One end of the ice transport tube has 1/8" holes drilled into it; this end connects on the inside of the Vision dispenser.
- Insulate entire length of ice transport tube ❶
- Secure ice transport tube ❷ as needed to prevent dips and traps from forming. For long tube runs see guide on page 15.
- Pitch ice transport tube at least 1/4" per foot (6,4 mm/0,3 m) ❸, Ice transport tube must drain towards ice machine

Ice transport tube to Ice machine

- Be sure tube ends are square ❹
- Heat end of transport tube in cup of 160 F (71 C) hot water to soften and spread with pliers ❺ before making connection to ease assembly
- Push plug end of ice transport tube onto ice machine nipple ❻
- Install hose clamp ❼ tightly so tube swells, ensuring hose clamp is installed on barb

Connect utilities to docking assembly.

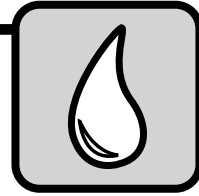

6.1 Water and flush drain

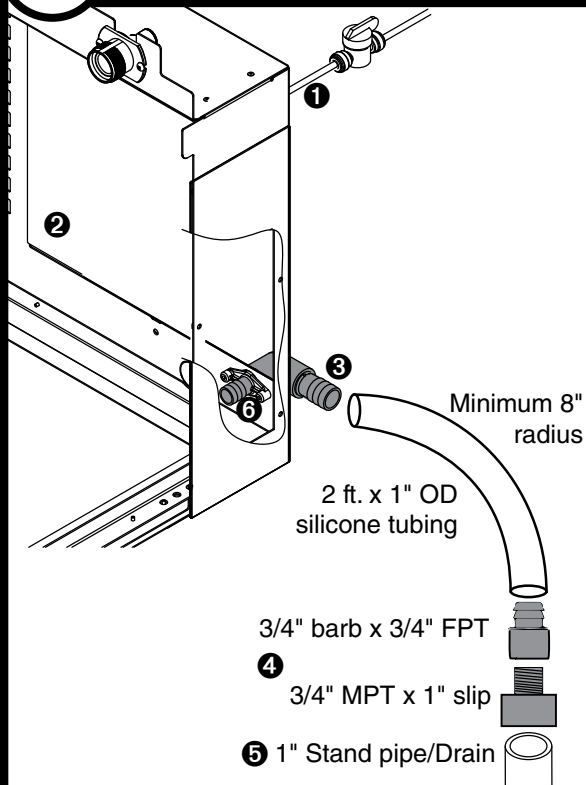

- Rough-in ice machine potable water supply ①. 3/8" push-in connection will be made at included shut-off valve then at back of docking station into solenoid.
- Remove access panel if necessary ②.
- Connect the silicone tubing to the ice machine 3/4" drain barb ③.
- It is recommended that the silicone hose be routed down into a 1.5" or 2" standpipe/drain. The minimum drain size for the ice machine is 1" ④.

Note: 3/4" to 1" PVC adapter fittings are provided if a larger drain size is not possible.

- If using the fittings, connect the 1" slip fitting to the 1" stand pipe/drain ⑤.

Note: Minimum 8" radius on silicone drain line. Drain line from the ice machine must have at least 1/4" per foot pitch (6,4 mm/0,3 m).

- Apply Petrol-gel to barbed drain fitting ⑥
- Replace access panel.

Chassis drain plumbing - required

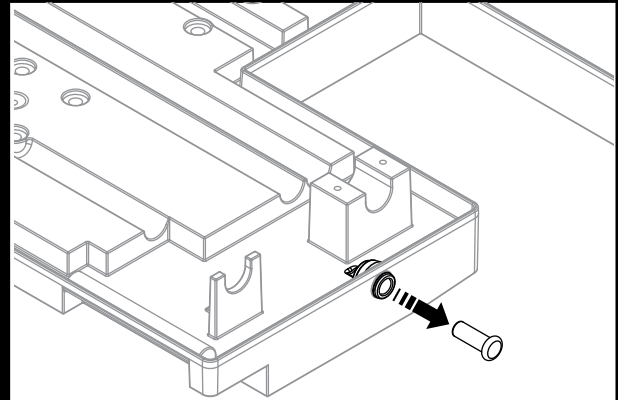

- Plug must be removed from John Guest fitting.
- Route 3/8" OD drain tubing (preferably copper) through rear of docking station and fully insert into chassis base push-in fitting. Route into drain standpipe.
- Gravity drain. Ensure 3/8" OD tubing slopes down into drain standpipe without forming a trap.

6.2 Refrigerant lines

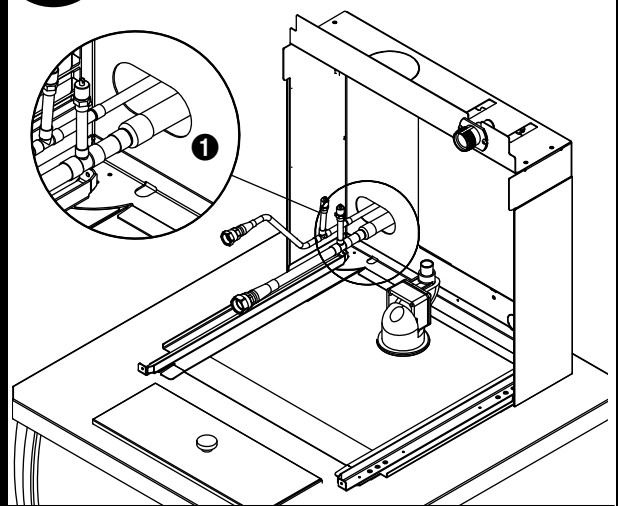

- Braze supplied quick-connect lines onto stub-ins ①.

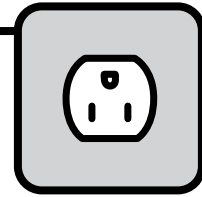

7.1 Ice transport tube installation

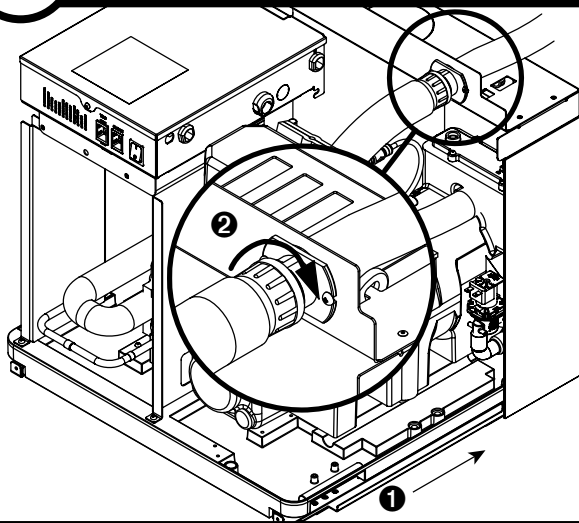

- Slide ice machine into docking assembly ensuring that drain tube is fully seated on barbed drain fitting **1**
- Insert ice transport tube all the way into coupling and tighten nut firmly **2**

7.2 Water solenoid, shut-off valve, and potable water line options

If water solenoid is already mounted to evaporator:

- Insert potable water line into shut-off valve.

If this is an undercounter installation:

- Mount water solenoid atop evaporator and locate the shut-off valve inside the machine. Insert potable water line into shut-off valve.

If water solenoid is not mounted and machine will not be installed under-counter:

- Mount water solenoid to *inside* rear (upper right corner) of docking assembly using one screw.
- Insert potable water line into shut-off valve - locate the shut-off valve *outside* the machine.
- Insert outgoing line from shut-off valve into push-in connection of water solenoid.

7.3 Refrigeration lines

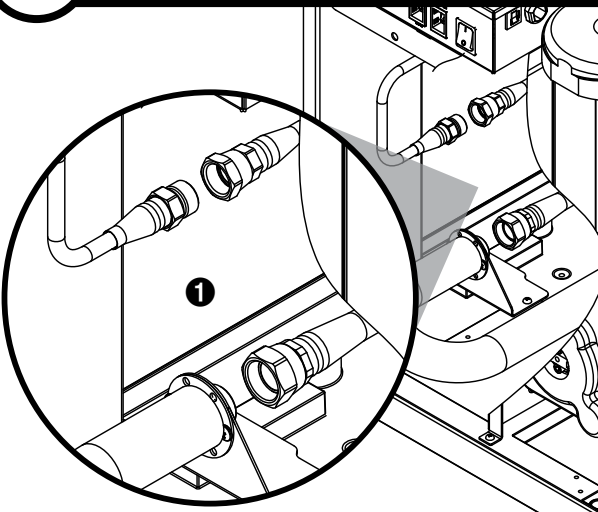

- Evacuate line set.
- Connect self-sealing liquid and suction line fittings **1**

7.4 Power cord

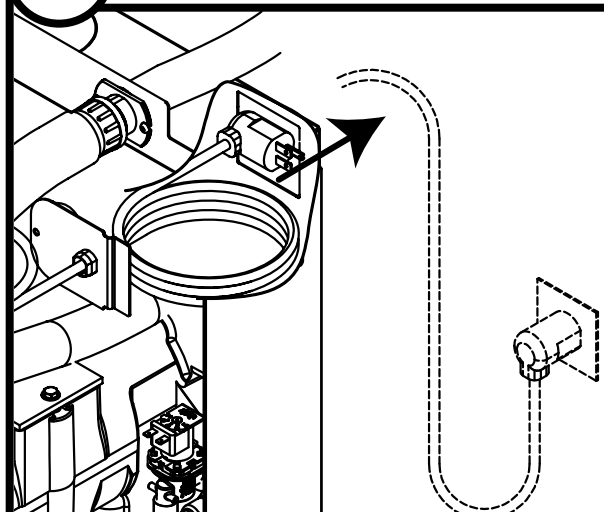

- Remove twist tie
- Carefully pass cord through opening and plug into wall outlet

7.5 Power cord

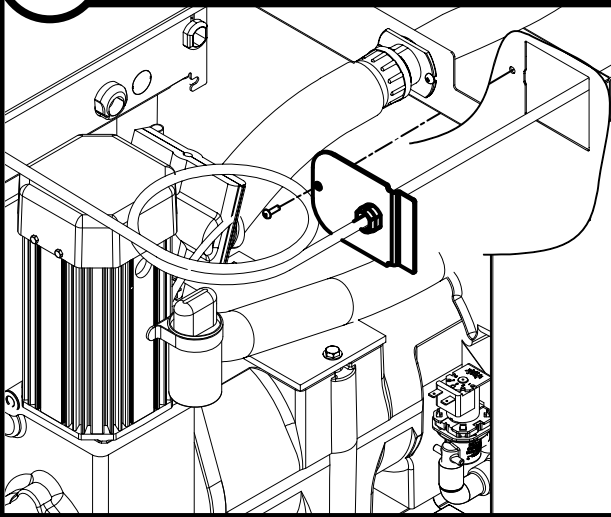

- Position plate into opening and secure with supplied screw

7.6 TDS switch

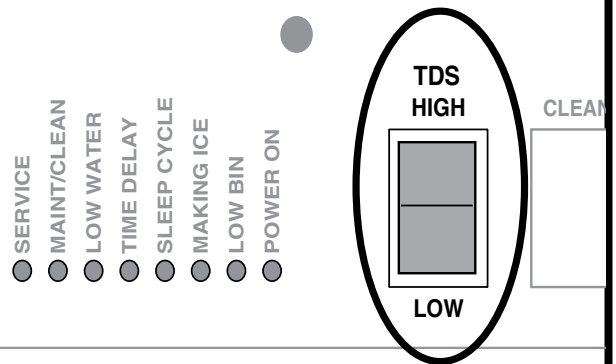

- Set the TDS switch on the electrical box:
HIGH: for extended service life
LOW: for low-scale water

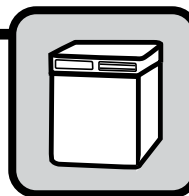

8.1 Install condensing unit

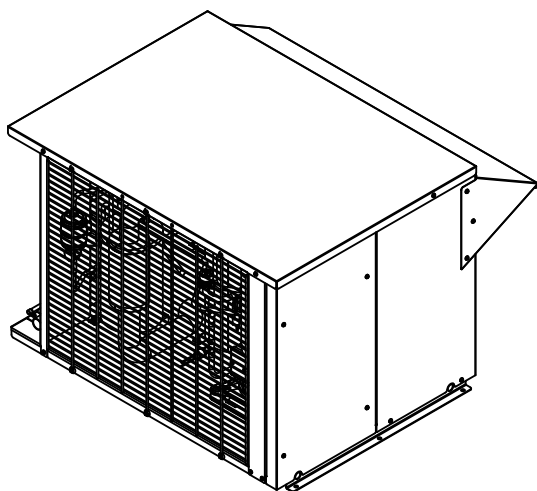

- Complete installation of condensing unit or connection to rack system.
- Required rack system capacity at 0 F (-18 C) evaporator (EPR supplied by installer).
1010CU: 7,700 Btu/hr (1940 kcal/hr)
1410CU: not rack compatible
1810CU: 15,700 Btu/hr (3956 kcal/hr)
2110CU: 18,200 Btu/hr (4586 kcal/hr).

8.2 Install ice machine front cover

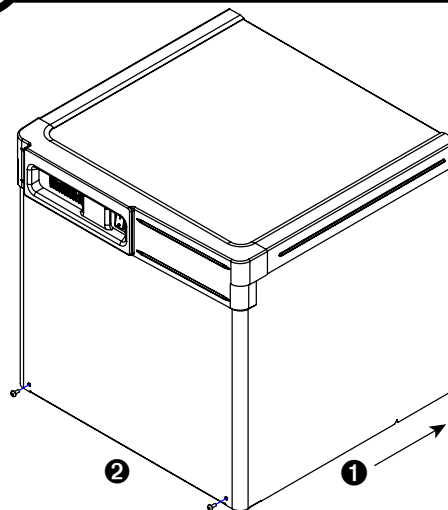

- Slide ice machine cover over machine ①
- Insert and tighten two screws through cover and into docking assembly ②

NOTICE

Ice machine MUST be sanitized prior to operation!

Consult Operation and Service Manual provided with ice machine for sanitizing instructions.

Long tube run recommendations

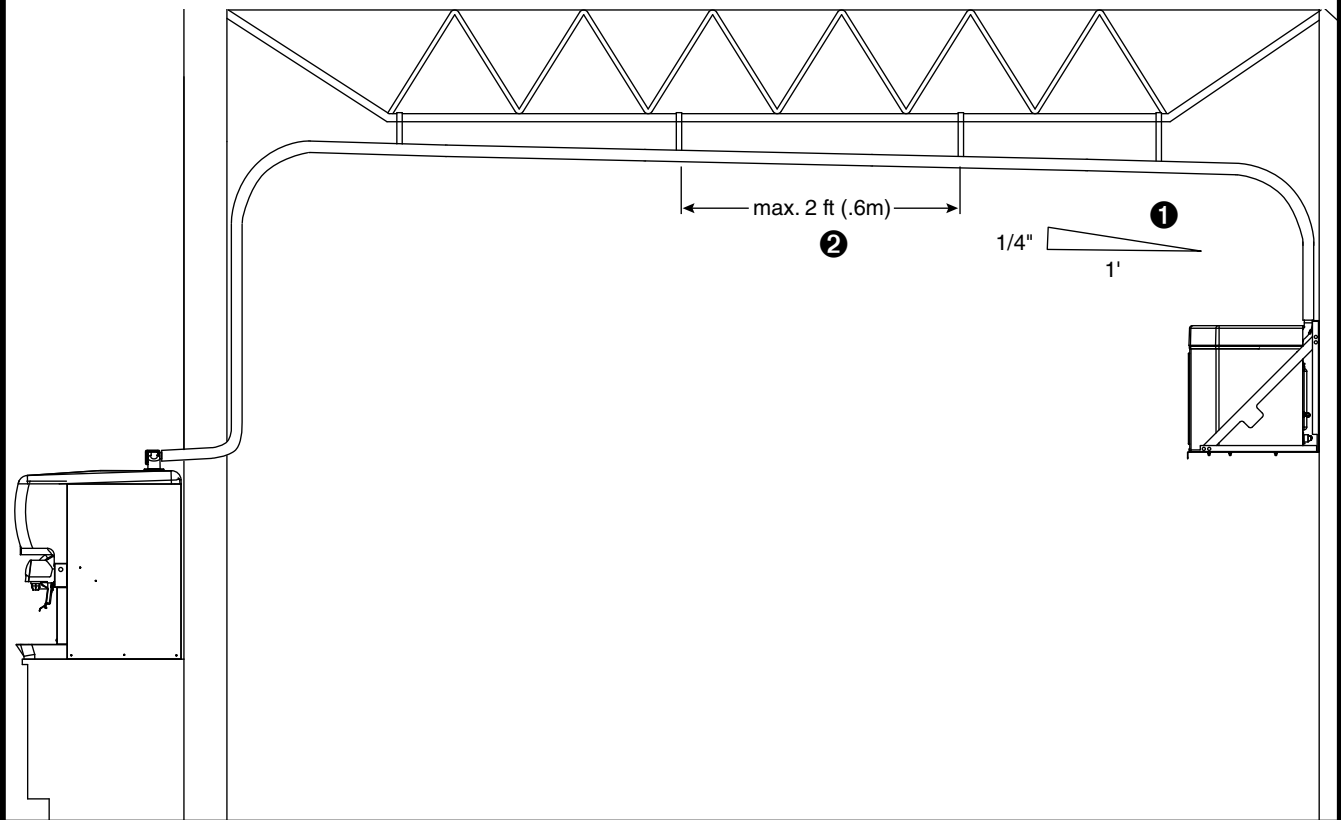

- Pitch ice transport tube to allow melt water to drain towards ice machine ❶
- Secure insulated ice transport tube at least every 2 ft (0,6 m) to prevent dips or traps ❷

Maestro, Vision, Ice Manager, Horizon Elite are trademarks of Follett Products, LLC.
Chewblet, RIDE, Follett are registered trademarks of Follett Products, LLC.

FOLLETT® 801 Church Lane • Easton, PA 18040, USA
Toll free (877) 612-5086 • +1 (610) 252-7301
www.follettice.com

01565100R00
© Follett Products, LLC 11/24