

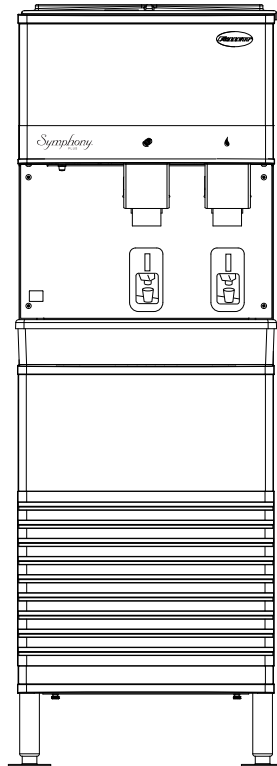

# Symphony Plus™ 25 and 50 Series Ice and Water Dispensers 25FB414A/W, 50FB414A/W

## Installation Guide

Please visit <https://www.follettice.com/technicaldocuments> for the Operation and Service manual for your unit.



### Welcome to Follett

Follett equipment enjoys a well-deserved reputation for excellent performance, long-term reliability and outstanding after-the-sale support. To ensure that this equipment delivers that same degree of service, review this guide carefully before you begin your installation.

Should you have need technical help, please call our Technical Service group at (877) 612-5086 or (610) 252-7301.

Please have your model number, serial number and complete and detailed explanation of the problem when contacting Technical Service.

### Getting Started

After uncrating and removing all packing material. Inspect the equipment for concealed shipping damage. All freight is to be inspected upon delivery. If visible signs of damage exist, please refuse delivery or sign your delivery receipt "damaged." Follett Customer Service must be notified within 48 hours. Wherever possible, please include detailed photos of the damage with the original packaging so that we may start the freight claim process.



**WARNING! Risk of fire or explosion. Flammable refrigerant used. Follow handling instruction carefully. To be repaired only by trained service Personnel.**



**WARNING! Do not puncture Refrigerant Tubing. Do not use this product with flammable gases or flammable solvents.**



**WARNING! Do not store flammable gases, flammable liquids or flammable solids in these units. Do not use FLAME to check for gas leak.**



**WARNING! Do not under any circumstances try to modify or repair valves, regulator, connectors, controls or any other appliance. Doing so creates the risk of a gas leak.**



**WARNING! Keep ventilaton openings clear of obstruction.**



**WARNING! Do not damage the refrigerant circuit.**



**WARNING! Connect to potable water supply only.**

### **WARNING!**

- Read this manual thoroughly before operating, installing or performing maintenance on the equipment. Failure to follow instructions in this manual can cause property damage, injury or death.
- The ice machine contains R290 (propane) refrigerant. R290 (propane) is flammable in concentrations of air between approximately 2.1% and 9.5% by volume. R290 (propane) may burn if exposed to a heat source above 470 °C.
- When servicing this equipment, be sure to lock the circuit breaker, and display an in-service notice.
- This equipment contains high-voltage electricity and refrigerant charge. Installation and repairs are to be performed by properly trained technicians aware of the dangers of dealing with high voltage electricity and refrigerant under pressure. The technician must also be certified in proper refrigerant handling and servicing procedures. All lockout and tag out procedures must be followed when working on this equipment.
- Repair on R290 systems must always be done in a well-ventilated area.
- Because R290 is highly flammable, a combustible gas leak detector is required when servicing R290 systems.
- Only use parts recommended or provided by the manufacturer.
- Routine adjustments and maintenance procedures outlined in this manual are not covered by the warranty.
- This equipment is intended for indoor use only. Do not install or operate this equipment in outdoor areas.
- We reserve the right to make product improvements at any time. Specifications and design are subject to change without notice.
- Do not tilt unit further than 30° off vertical during uncrating or installation.
- This appliance is not suitable for installation in an area where a water jet could be used.
- This appliance must not be cleaned by a water jet.
- User maintenance should not be done by children.
- Follett recommends a Follett water filter system be installed in the ice machine inlet water line (standard capacity, high capacity, carbonless high capacity).
- Do not block air intake or exhaust.
- This appliance should be permanently connected by a qualified person in accordance with application codes.
- A qualified person shall provide a readily accessible disconnect device incorporated into the fixed wiring.
- If the supply cord is damaged, it must be replaced by the manufacturer, its service agent or similarly qualified persons in order to avoid a hazard.
- This appliance can be used by children aged 8 years and above and persons with reduced physical, sensory, or mental capabilities, or lack of experience and knowledge if they have been given supervision or instruction concerning use of the appliance in a safe way and understand the hazards involved. Children should be supervised to ensure that they do not play with the appliance.
- This appliance is designed for commercial use.
- **WARNING!** To avoid a hazard due to instability of the appliance, it must be fixed in accordance with the instructions.
- Warranty does not cover exterior or outside installations.
- To reduce risk of shock, disconnect power before servicing.
- Connect to potable water supply only.
- Ice is slippery. Maintain counters and floors around dispenser in a clean and ice-free condition.
- Ice is food. Follow recommended cleaning instructions to maintain cleanliness of delivered ice.

## Specifications

### Electrical

- Freestanding models (25FB414A/W, 50FB414A/W) require a dedicated circuit.

	Total system	Max. fuse
Basic electrical: 115 V/60 Hz/1 phase	11.0A	15A

- Dispensers and RIDE ice machines are supplied with 7-foot power cord with NEMA 5-15 hospital-grade plug. Connect to a dedicated 15A dedicated circuit.

**Note:** It is preferred that circuit be protected by a GFCI.

Model	Electrical connection	Circuits required
25FB414A/W, 50FB414A/W	cord & plug provided	115/60/1, 20A max. fuse size

### Ambient

Air temp	100 F/38 C Max.	50 F/10 C Min. (Best performance below 80 F/27 C)
Water temp	90 F/32 C Max.	45 F/7.2 C Min. (Best performance below 70 F/21 C)
Water pressure (psi/bar)	70/5 Max.	10/0.7 Min.

### Plumbing

	25/50 FB with ice machine in base
Dispenser drain	3/4" MPT
Ice machine drain	3/4" MPT
Dispenser water inlet	3/8" FPT
RIDE IM water inlet	–
Cond. inlet – w/c only	3/8" FPT
Cond. drain – w/c only	3/8" FPT

**Note:** Water shut-off recommended within 10 ft. (3 m) of dispenser. Drain to be hard-piped and insulated. Maintain at least 1/4" per foot (20 mm per 1 m) run of slope.

### Ventilation clearances

- 3" (7.7 cm) right, left, rear and 4" (10.2 cm) top required at rear for freestanding models (25FB414A/W, 50FB414A/W).

**Note:** 12" (30.5 cm) at top advised for service.

### Dry weight

- 25/50 FB 212 lb (96 kg)

# Installation

## Before you begin

- All dispensers must be installed level in both directions to ensure proper operation.
- SensorSAFE™ dispensers are shipped with a plastic, protective film on sensor lenses. For proper operation, plastic film must be removed after installation.

## Installing freestanding dispensers

1. Position dispenser in desired location and adjust legs to level in both directions.
2. Connect water supply to 3/8" FPT fitting on back of dispenser (**Fig. 1**).
3. Connect separate drain lines to 3/4" MPT dispenser drain fitting, and 3/4" MPT ice machine drain fitting on back of dispenser.
4. Run drain lines to wall or floor drain. If ice machine drain fitting is below an intended wall drain, a condensate pump must be used.
5. If ice machine is a water-cooled unit, connect water-cooled condenser supply line to 3/8" FPT condenser inlet fitting on back of dispenser.

**Note: Do not run condenser supply water through ice machine water filter system.**

6. Connect condenser drain line to 3/8" FPT condenser outlet fitting on back of dispenser.  
**Important: Do not connect condenser drain line to any other drain lines.**
7. Plug dispenser into 15A rated NEMA 5-15 wall socket.
8. Remove front cover of base section by removing two screws at bottom corners of cover. Allow cover to drop approximately 3/8" (5 mm) and pull forward.
9. Turn on water supply and check for leaks.

**Fig. 1 – Rear connections, freestanding models**

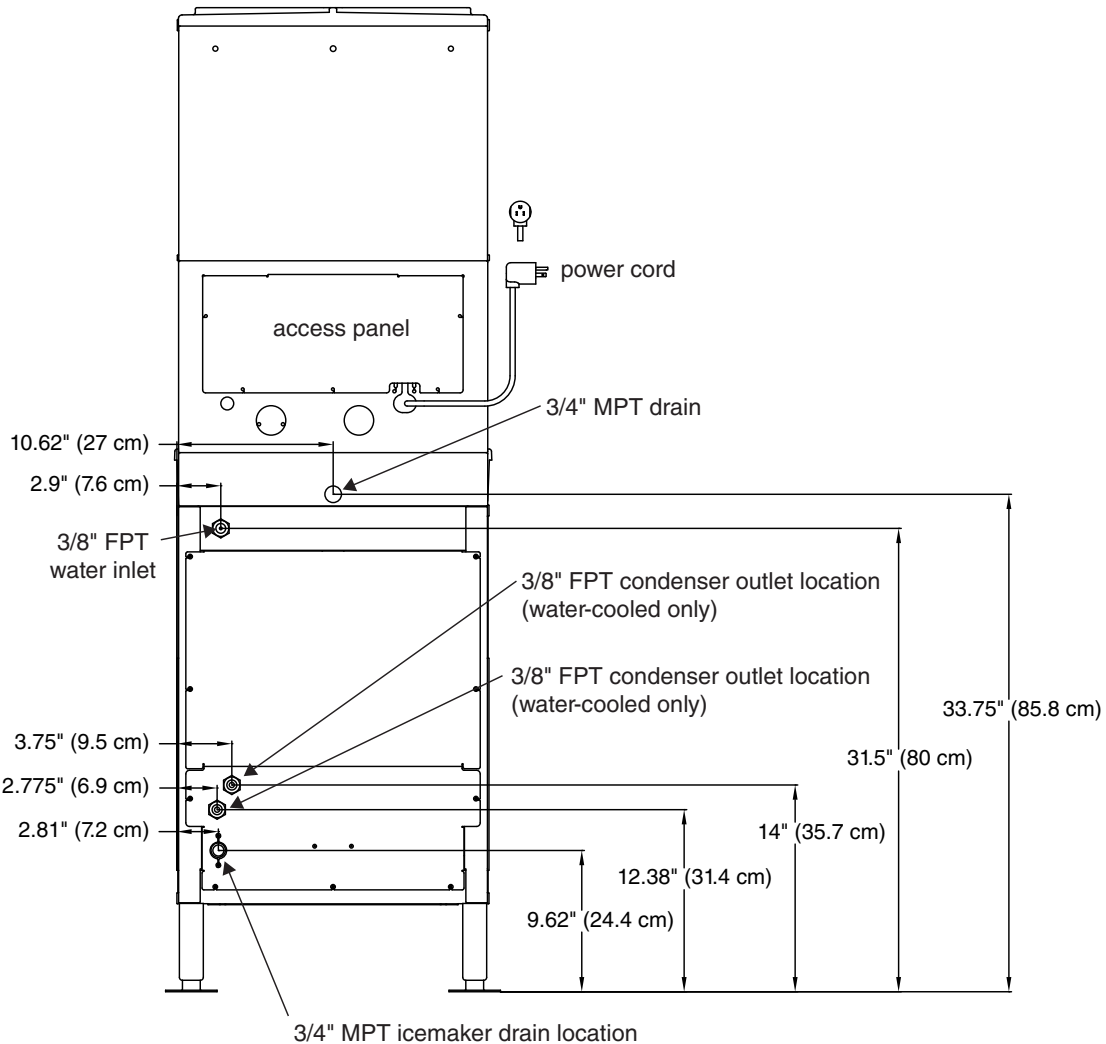

10. Remove top front cover by removing two screws at bottom corners of cover. Lift cover slightly and pull forward.
11. If dispenser is equipped with SensorSAFE remove protective plastic coating from dispense sensor labels.
12. Turn on dispenser power and bin signal rocker switches. Check dispenser and ice machine operation.
13. Clean ice machine according to cleaning section. Discard ice made during cleaning process.
14. Turn off ice machine bin signal switch.
15. Remove dispenser hopper lid; clean dispenser according to instructions in Cleaning section.
16. Turn ice machine bin signal switch on and replace front covers, securing with screws.

## Cleaning and sanitizing

Follett ice machines and dispensers, and their associated cleaning and sanitizing procedures, are designed for use with potable water sources. The presence, or suspected presence, of infectious agents may call for additional measures, including the replacement of components and more comprehensive disinfection measures. Follett recommends that these cleaning and sanitizing procedures be reviewed with the appropriate infectious agent subject matter experts to assure complete remediation.

Periodic cleaning of Follett's ice and water dispenser and ice machine system is required to ensure peak performance and delivery of clean, sanitary ice. The recommended cleaning procedures that follow should be performed at least as frequently as recommended and more often if environmental conditions dictate.

Follett recommends sanitizing the pressurized water lines prior to cleaning the ice machine/dispenser. Follett offers two kits: order P/N 01089572 when a Follett filter system with a pre-filter bowl is present, or P/N 01089580 when a Follett filter system is not present. Follow the instructions provided with the respective kits to sanitize the pressurized water lines immediately before cleaning the ice machine/dispenser.

Cleaning of the condenser can usually be performed by facility personnel. Cleaning of the ice machine system should be performed by your facility's trained maintenance staff or a Follett authorized service agent. Regardless of who performs the cleaning, it is the operator's responsibility to see that this cleaning is performed according to the schedule below. Service problems resulting from lack of preventive maintenance will not be covered under the Follett warranty.

### Recommended cleaning intervals\*

Symphony Plus	Frequency
Drain Line	weekly
Drain Pan/Drip Pan	weekly
Exterior, Water Station Tube	as needed
Condenser	monthly (air-cooled only)
Dispenser and Components	semi-annually
Ice Machine	semi-annually
Transport Tube	semi-annually
Ice Storage Area/Bin	semi-annually
Pressurized Water Sanitizing	semi-annually

\* Ice machine and dispenser must be cleaned prior to start-up.

### Weekly

#### CAUTION!

- Do not use solvents, abrasive cleaners, metal scrapers or sharp objects to clean any part of the dispenser.

#### Dispenser drain pan and drain line

- Pour 1 gal. (3.8 L) of hot tap water into drain pan to flush drains.

#### Splash panel front, SensorSAFE infrared dispensing

- Deactivate dispensing by pressing and releasing clean switch located on left side of unit under top front cover.
- Clean lens and splash panel front using a soft cloth and mild, non-abrasive, non-chlorine based cleaner.
- Reactivate dispensing by pressing and releasing clean switch again.

### Monthly

#### CAUTION!

- Do not use solvents, abrasive cleaners, metal scrapers or sharp objects to clean any part of the dispenser.

#### Condenser (air-cooled ice machine only)

- Use a vacuum cleaner or stiff brush to carefully clean condenser coils of lint and debris to ensure optimal performance.

## Semi-Annually (more often if conditions dictate)

- A cleaning procedure should always include both the ice machine and dispenser; ice machine should be cleaned first, followed by the dispenser.
- Icemaking system can be cleaned in place.



### CAUTION!

- Wear rubber gloves and safety goggles (or face shield) when handling SafeCLEAN Plus™ and IMS-III solutions.
- Use only Follett approved cleaners.
- It is a violation of Federal law to use the Nu-Calgon® IMS-III solution in a manner inconsistent with its labeling.
- Do not use solvents, abrasive cleaners, metal scrapers or sharp objects to clean any part of the dispenser.

### Cleaning & Sanitizing Tool Checklist

- (1 or 2) 1.5 Gallon (or larger) plastic bucket
- (2) clean cloths
- Sanitary gloves
- Safety glasses
- (2) SaniSponge™ (P/N 00131524 - single sponge)
- SafeCLEAN Plus ice machine cleaner
- [OPTIONAL] Nu-Calgon IMS-III no-rinse sanitizer (P/N 00979674 – 16 fl oz. bottle)

**SafeCLEAN Plus Solution:** Follow the directions on the Follett Follett SafeCLEAN Plus packaging to mix 1 gal. (3.8 L) of cleaning solution. Use 100 F (38 C) water.

**[OPTIONAL] No-rinse Sanitizing Solution:** Follow the directions on the Nu-Calgon IMS-III Plus packaging to mix 1 gal. (3.8 L) of IMS-III solution. Use 100 F (38 C) water.

## Ice Machine and Dispenser

### Cleaning Procedure

**Note:** Check drains and drain cup to ensure they are open and flowing freely.

1. If ice machine was running recently, ensure that the evaporator is completely free of ice before proceeding. If there is ice in the evaporator, complete steps 2-7 using only hot water to remove the ice, then begin Cleaning/Descaling Procedure again.
2. Remove front cover and turn OFF bin signal switch.
3. Dispense all ice from storage hopper and discard.
4. Remove hopper lid.
5. Remove water reservoir drain tube from the evaporator drain bracket and lift tube to higher level than reservoir, placing it in plastic clip at right lower front.
6. Remove lid from cleaning cup, then hang the cleaning cup on plastic clip at left front of dispenser. Set cleaning cup aside, but do not discard.
7. Press **CLEAN** switch. The **MAINTENANCE** light will turn on and the machine will fill and drain three times. Wait for the **LOW WATER** light to turn on.
8. Fill cleaning cup until SafeCLEAN Plus solution completely fills the reservoir (about 1 quart). Place lid back on cup. Save remainder of SafeCLEAN Plus solution.
9. **CLEANER FULL** light will turn on and machine will start cleaning cycle then rinse three times; this process takes approximately 15 minutes.
10. While ice machine is cleaning, clean dispenser as follows:
  - 10.1 Remove knurled nuts from front of storage hopper.
  - 10.2 Remove stud assembly, baffle, wheel, and any remaining ice.
  - 10.3 Remove dispense chutes from splash panel.
  - 10.4 Submerge drain grill in SafeCLEAN Plus solution and allow to soak to remove any scale buildup.
  - 10.5 Wipe inside of hopper lid, stud assembly, baffle, wheel, inside of storage area, dispense chutes, drain grill and drain pan with damp cloth wrung out in SafeCLEAN Plus solution. Thoroughly rinse all parts with damp cloth wrung out with clean water.

**Note:** To avoid possible damage to motor assembly, only use a damp cloth to clean storage hopper. Do not allow water to run through motor shaft hole in bottom of hopper.

- 10.6 When machine is finished cleaning, the MAINTENANCE light will turn off.
11. Reinstall dispense chutes, wheel, baffle, stud assembly and knurled nuts. (See manual for correct baffle position.)

### Finish cleaning – SafeCLEAN Plus only

12. Remove top bearing insulation. Loosen Phillips-head screw on nozzle connected to evaporator. Remove nozzle from evaporator side only, leave other side of nozzle connected to transport tube.
13. Soak both Sani-Sponges in remaining SafeCLEAN Plus solution.
14. Insert both sponges soaked in SafeCLEAN Plus solution into nozzle one at a time.
15. Replace nozzle onto evaporator and tighten screw. Ensure drain is connected to reservoir and vent tubes are connected to evaporator drain pan. Replace top bearing insulation.
16. Lower water reservoir drain tube back to evaporator drain bracket.
17. Turn ON bin signal switch. Wait for ice to push sponges through transport tube.
18. Collect sponges from ice storage bin.
19. Replace hopper lid, machine top, turn ON dispenser power and install front cover.
20. After 10 minutes, dispense all ice and discard. 12. Remove top bearing insulation. Loosen Phillips-head screw on nozzle connected to evaporator. Remove nozzle from evaporator side only, leave other side of nozzle connected to transport tube.
21. Soak both Sani-Sponges in remaining SafeCLEAN Plus solution.
22. Insert both sponges soaked in SafeCLEAN Plus solution into nozzle one at a time.
23. Replace nozzle onto evaporator and tighten screw. Ensure drain is connected to reservoir and vent tubes are connected to evaporator drain pan. Replace top bearing insulation.
24. Lower water reservoir drain tube back to evaporator drain bracket.
25. Turn ON bin signal switch. Wait for ice to push sponges through transport tube.
26. Collect sponges from ice storage bin.
27. Replace hopper lid, machine top, turn ON dispenser power and install front cover.
28. After 10 minutes, dispense all ice and discard.

### [OPTIONAL] Finish cleaning – No-rinse sanitizing with Nu-Calgon IMS-III

12. Press **CLEAN** switch. The **MAINTENANCE** light will turn on and the machine will fill and drain three times. Wait for the **LOW WATER** light to turn on.
13. Remove lid from cleaning cup and fill (about 1 quart) until sanitizing solution completely fills the reservoir. Place lid back on cup. Save remainder of sanitizing solution.
14. **CLEANER FULL** light will turn on and machine will start sanitizing cycle, then rinse three times; this process takes approximately 15 minutes.
15. While ice machine is sanitizing, sanitize dispenser as follows:
  - 28.7 Wipe inside of hopper lid, stud assembly, baffle, wheel, inside of storage area, dispense chutes, drain grill and drain pan with damp cloth wrung out in sanitizing solution. Do not rinse off the sanitizing solution.

**Note:** To avoid possible damage to motor assembly, only use a damp cloth to clean storage hopper. Do not allow water to run through motor shaft hole in bottom of hopper.
16. Reinstall dispense chutes, wheel, baffle, stud assembly and knurled nuts. (See manual for correct baffle position.) Reinstall dispense chutes, wheel, baffle, stud assembly and knurled nuts. (See manual for correct baffle position.)
17. When machine is finished rinsing, the **MAINTENANCE** light will turn off.
18. Remove top bearing insulation. Loosen Phillips-head screw on nozzle connected to evaporator. Remove nozzle from evaporator side only, leave other side of nozzle connected to transport tube.
19. Soak one SaniSponge in remaining sanitizing solution. Insert the sponge soaked in sanitizing solution into nozzle, then insert a dry sponge into the nozzle.
20. Replace nozzle onto evaporator and tighten screw. Ensure drain is connected to reservoir and vent tubes are connected to evaporator drain pan. Replace top bearing insulation.
21. Turn ON bin signal switch. Wait for ice to push sponges through transport tube.
22. Collect sponges from ice storage bin.
23. Replace hopper lid, base stand cover, and install dispenser front cover.
24. After 10 minutes, dispense all ice and discard.

### User Interface and Exterior Cabinet

- Clean stainless steel panels with stainless steel cleaner.



# Dispenser troubleshooting

 **CAUTION!**

- Disconnect power to unit before putting hands or arms in storage area or attempting any repair or service to equipment.

**Before calling for service**

1. Check that no ice is in the dispenser bin area.
2. Check that congealed ice is not causing a jam.
3. Check that all switches and circuit breakers are on.
4. Check that all drains are clear.
5. Check that water is supplied.

**Lever model troubleshooting guide**

Problem	Indicators	Corrective Action
Does not dispense ice.	<ol style="list-style-type: none"> <li>1. Power switch off or faulty.</li> <li>2. Faulty dispense switch.</li> <li>3. Wheel motor malfunction.</li> <li>4. Defective control board.</li> <li>5. Defective wiring.</li> </ol>	<ol style="list-style-type: none"> <li>1. Turn on or replace the defective switch.</li> <li>2. Replace defective switch.</li> <li>3. Verify voltage at motor and replace wheel motor if defective.</li> <li>4. Jumper pins 1 &amp; 2 on connector P13.               <ol style="list-style-type: none"> <li>a. Control board output LED, D19 should light. Replace board, if D19 does not come on.</li> <li>b. D19 comes on but no voltage at wheel motor. Move connector from P6 to L1, if motor runs, replace control board.</li> </ol> </li> <li>5. Ohm check wiring going from lever switch to P13 pins 1 &amp; 2. Ohm check wiring from P6 to wheel motor and neutral wire to neutral on control board. Repair or replace as needed.</li> </ol>
Dispense wheel rotates continuously.	Dispense switch contacts are welded together.	Replace dispense switch.
Ice machine runs continuously.	Faulty or incorrectly positioned bin thermostat.	Check for proper positioning. If thermostat does not open when ice is placed on capillary tube, replace thermostat.
Does not dispense water.	<ol style="list-style-type: none"> <li>1. Power switch off/faulty.</li> <li>2. Faulty water dispense switch.</li> <li>3. Water dispense solenoid malfunction.</li> <li>4. Defective control board.</li> <li>5. Defective wiring.</li> </ol>	<ol style="list-style-type: none"> <li>1. Turn on or replace the defective switch.</li> <li>2. Replace defective switch.</li> <li>3. Verify voltage at water dispense solenoid and replace water dispense solenoid if defective.</li> <li>4. Jumper pins 3 &amp; 4 on connector P13.               <ol style="list-style-type: none"> <li>a. Control board output LED, D21 should light. Replace board, if D21 does not come on.</li> <li>b. D21 comes on but no voltage at wheel motor. Move connector from P20 to L1, if motor runs, replace control board.</li> </ol> </li> <li>5. Ohm check wiring going from lever switch to P13 pins 3 &amp; 4. Ohm check wiring from P20 to wheel motor and neutral wire to neutral on control board. Repair or replace as needed.</li> </ol>

## SensorSAFE model troubleshooting guide

Problem	Indicators	Corrective Action
Does not dispense ice.	<ol style="list-style-type: none"> <li>1. Power switch off or faulty.</li> <li>2. Power on but no ice dispensing</li> <li>3. Faulty ice dispense sensor.</li> <li>4. Wheel motor malfunction.</li> <li>5. Defective control board/ daughter card.</li> <li>6. Defective wiring.</li> </ol>	<ol style="list-style-type: none"> <li>1. Turn on or replace the defective switch.</li> <li>2. Verify daughter card is properly aligned and inserted with pins on the control card and bin lid jumper is installed.</li> <li>3. Follow the steps below for ice dispensing.               <ol style="list-style-type: none"> <li>a. If ice and water dispenser, switch connectors going from sensors to daughter and if problem follows to opposite input, replace defective sensor.</li> <li>b. Once switched, if problem stays with same input, jumper pins 3 &amp; 4 on daughter card ice connector and the control board output LED, D19 should light. Replace board, if D19 does not come .</li> </ol> </li> <li>4. Verify 120 vac at motor and replace wheel motor if defective.</li> <li>5. D19 comes on but no voltage at wheel motor. Move connector from P6 to L1, if motor runs, replace control board.</li> <li>6. Ohm check wiring from P6 to wheel motor and neutral wire to neutral on control board. Repair or replace as needed.</li> </ol>
Does not dispense water	<ol style="list-style-type: none"> <li>1. Power switch off/faulty.</li> <li>2. Faulty water dispense sensor.</li> <li>3. Water dispense solenoid malfunction or defective control board/daughter card.</li> <li>4. Defective wiring.</li> </ol>	<ol style="list-style-type: none"> <li>1. Turn on or replace the defective switch.</li> <li>2. Follow the steps below for water dispensing.               <ol style="list-style-type: none"> <li>a. If ice and water dispenser, switch connectors going from sensors to daughter and if problem follows to opposite input, replace defective sensor.</li> <li>b. Once switched, if problem stays with same input, jumper pins 3 &amp; 4 on daughter card water connector and the control board output LED, D21 should light. Replace control board/daughter card, if D21 does not come on. If D21 comes on, move connector from P20 to L1, if solenoid energizes, replace control board.</li> </ol> </li> <li>3. Verify 120 VAC at solenoid and replace if present.</li> <li>4. Ohm check wiring going from water solenoid to P20 terminal on control board. Ohm check wiring from water solenoid neutral wire to neutral on control board. Repair or replace as needed.</li> </ol>
Ice machine runs continuously.	Faulty or incorrectly positioned bin thermostat.	Check for proper positioning. If thermostat does not open when ice is placed on capillary tube, replace bin thermostat.

## Warranty Registration and Equipment Evaluation

Thank you for purchasing Follett® equipment. Our goal is to deliver high value products and services that earn your complete satisfaction by delivering high-value products and services backed by outstanding customer and technical support.

Please review the installation instructions thoroughly. It is important that the installation be performed to factory specifications so your equipment operates at its maximum efficiency.

Follett LLC will not be liable for any consequential damages, expenses, connecting or disconnecting charges, or any losses resulting from a defect of the machine. For full warranty details, visit our website [www.follettice.com/productwarranties](http://www.follettice.com/productwarranties).

Registering your equipments helps Follett track your equipment's service history should you need to contact us for technical support, and your feedback helps us improve our products and services. Please visit [www.follettice.com/support](http://www.follettice.com/support) to complete the Warranty Registration form.

Should you have any questions, please contact Follett's technical support group at (877) 612-5086 or (610) 252-7301 and we will be happy to assist you.

Calgon is a licensed trademark distributed by Nu-Calgon, in the United States.  
SafeCLEAN, SaniSponge, SensorSAFE, and Symphony Plus are trademarks of Follett Products, LLC.  
Follett is a registered trademarks of Follett Products, LLC, registered in US.



801 Church Lane • Easton, PA 18040, USA  
Toll free (877) 612-5086 • +1 (610) 252-7301  
[www.follettice.com](http://www.follettice.com)



01568245R00  
© Follett Products, LLC 11/24