



# Symphony Plus™ 12 Series Ice and Water Dispensers

R290, 230 V/50 Hz

## Installation Guide

Please visit <https://www.follettice.com/technicaldocuments> for the Operation and Service manual for your unit.

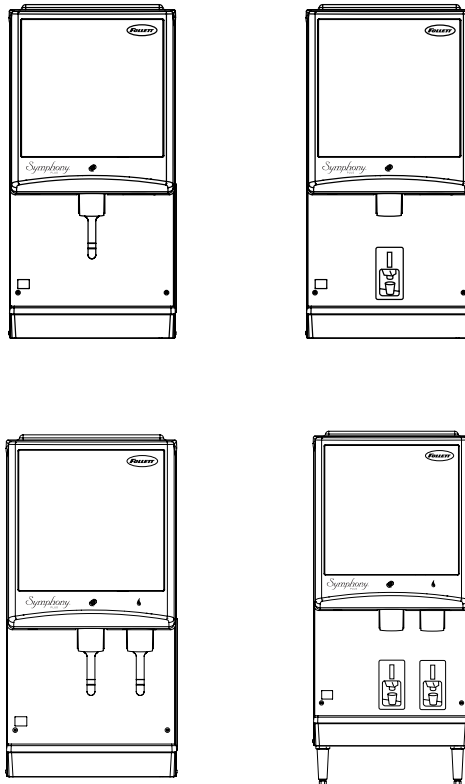

### Welcome to Follett

Follett equipment enjoys a well-deserved reputation for excellent performance, long-term reliability and outstanding after-the-sale support. To ensure that this equipment delivers that same degree of service, review this guide carefully before you begin your installation.

Should you have need technical help, please call our Technical Service group at (877) 612-5086 or (610) 252-7301.

Please have your model number, serial number and complete and detailed explanation of the problem when contacting Technical Service.

### Getting Started

After uncrating and removing all packing material. Inspect the equipment for concealed shipping damage. All freight is to be inspected upon delivery. If visible signs of damage exist, please refuse delivery or sign your delivery receipt "damaged." Follett Customer Service must be notified within 48 hours. Wherever possible, please include detailed photos of the damage with the original packaging so that we may start the freight claim process.



**WARNING! Risk of fire or explosion. Flammable refrigerant used. Follow handling instruction carefully. To be repaired only by trained service Personnel.**



**WARNING! Do not puncture Refrigerant Tubing. Do not use this product with flammable gases or flammable solvents.**



**WARNING! Do not store flammable gases, flammable liquids or flammable solids in these units. Do not use FLAME to check for gas leak.**



**WARNING! Do not under any circumstances try to modify or repair valves, regulator, connectors, controls or any other appliance. Doing so creates the risk of a gas leak.**



**WARNING! Keep ventilaton openings clear of obstruction.**



**WARNING! Do not damage the refrigerant circuit.**



**WARNING! Connect to potable water supply only.**

## **WARNING!**

### **Installation**

- Read this manual thoroughly before operating, installing or performing maintenance on the equipment. Failure to follow instructions in this manual can cause property damage, personal injury, or death.
- The ice machine contains R290 (propane) refrigerant. R290 (propane) is flammable in concentrations of air between approximately 2.1% and 9.5% by volume. R290 (propane) may burn if exposed to a heat source above 470 °C.
- Because R290 is highly flammable, a combustible gas leak detector is required when servicing R290 systems.
- This equipment contains high-voltage electricity and refrigerant charge. Installation and Service repairs are to be performed by properly trained technicians aware of the dangers of dealing with high voltage electricity and refrigerant under pressure. The technician must also be certified in proper refrigerant handling and servicing procedures.
- All lockout and tag out procedures must be followed when working on this equipment.
- A qualified person shall provide a readily accessible disconnect device incorporated into the fixed wiring.
- This appliance should be permanently connected by a qualified person in accordance with application codes.
- If the supply cord is damaged, it must be replaced by the manufacturer, its service agent or similarly qualified persons in order to avoid a hazard.
- Do not tilt unit further than 30° off vertical during uncrating or installation.
- This appliance is designed for commercial use.
- This equipment is intended for indoor use only. Do not install or operate this equipment in outdoor areas.
- Warranty does not cover exterior or outside installations.
- To avoid a hazard due to instability of the appliance, it must be fixed in accordance with the instructions.
- Maintain all minimum clearances. DO NOT obstruct vents or openings.
- This appliance is not suitable for installation in an area where a water jet could be used.
- Connect to potable water supply only.
- Follett recommends a Follett water filter system be installed in the ice machine inlet water line (standard capacity, high capacity, carbonless high capacity).
- We reserve the right to make product improvements at any time. Specifications and design are subject to change without notice.

### **Usage**

- Read this manual thoroughly before operating, installing or performing maintenance on the equipment. Failure to follow instructions in this manual can cause property damage, personal injury, or death.
- User maintenance should not be done by children.
- This appliance can be operated by children aged 8 years and above and persons with reduced physical, sensory, or mental capabilities, or lack of experience and knowledge if they have been given supervision or instruction concerning use of the appliance in a safe way and understand the hazards involved. Children should be supervised to ensure that they do not play with the appliance.
- If the supply cord is damaged, it must be replaced by the manufacturer, its service agent or similarly qualified persons in order to avoid a hazard.
- Routine adjustments and maintenance procedures outlined in this manual are not covered by the warranty.

- Maintain all minimum clearances. DO NOT obstruct vents or openings.
- This appliance must not be cleaned by a water jet.
- Connect to potable water supply only.
- Ice is food. Follow recommended cleaning instructions to maintain cleanliness of delivered ice.
- Ice is slippery. Maintain counters and floors around dispenser in a clean and ice-free condition.
- We reserve the right to make product improvements at any time. Specifications and design are subject to change without notice.

### **Service**

- Read this manual thoroughly before operating, installing or performing maintenance on the equipment. Failure to follow instructions in this manual can cause property damage, personal injury, or death.
- Review Installation section.
- This equipment contains high-voltage electricity and refrigerant charge. Installation and Service repairs are to be performed by properly trained technicians aware of the dangers of dealing with high voltage electricity and refrigerant under pressure. The technician must also be certified in proper refrigerant handling and servicing procedures.
- To reduce risk of shock, disconnect power before servicing.
- When servicing this equipment, be sure to lock the circuit breaker, and display an in-service notice.
- Repair on R290 systems must always be done in a well-ventilated area.
- If the supply cord is damaged, it must be replaced by the manufacturer, its service agent or similarly qualified persons in order to avoid a hazard.
- Only use parts recommended or provided by the manufacturer. Use of unapproved parts can be dangerous due to design requirements to safely use R290 (propane).
- Routine adjustments and maintenance procedures outlined in this manual are not covered by the warranty.
- Maintain all minimum clearances. DO NOT obstruct vents or openings.
- This appliance must not be cleaned by a water jet.
- Connect to potable water supply only.
- We reserve the right to make product improvements at any time. Specifications and design are subject to change without notice.

### **Decommissioning and Dismantling**

- Read this manual thoroughly before operating, installing or performing maintenance on the equipment. Failure to follow instructions in this manual can cause property damage, personal injury, or death.
- Decommissioning and Dismantling are to be performed by properly trained technicians aware of the dangers of dealing with high voltage electricity and refrigerant under pressure. The technician must also be certified in proper refrigerant handling procedures for R290 (flammable) refrigerant.
- Review Installation section.
- Ensure area is being well-ventilated before Decommissioning and Dismantling of equipment using R290 (flammable) refrigerant.
- When servicing this equipment, be sure to lock the circuit breaker, and display an in-service notice.
- To reduce risk of shock, disconnect power before servicing.
- Utilize and maintain good safety practices and follow all applicable local, state, and federal regulations for proper decommissioning and disposal of the equipment.
- Ensure all personal protective equipment is used during the entire process.
- Ensure all necessary tools and equipment are available, including recovery equipment and cylinders.
- All containers used for recovery must have proper labelling to ensure they can be used for R290 (flammable) refrigerant.
- Before starting recovery, place refrigerants on scales. Do not overfill containers more than 80% of volume, and do not exceed working pressure of the container.
- Before using a recovery machine, ensure that it is in satisfactory working order and that the electrical components are properly sealed to prevent any type of ignition.
- Recovered refrigerant shall not be added or used in another refrigerating system or mixed into another container.
- If the compressor or compressor oils are removed, ensure it has been removed to an acceptable level so that flammable refrigerant does not remain in the lubricant.

### **Disposal**

- Follow all applicable local, state, and federal regulations for proper disposal of the equipment.
- All recovered refrigerant must be returned to an appropriate refrigerant supplier for proper disposal.
- DO NOT dispose of your appliance with household waste.

## Specifications

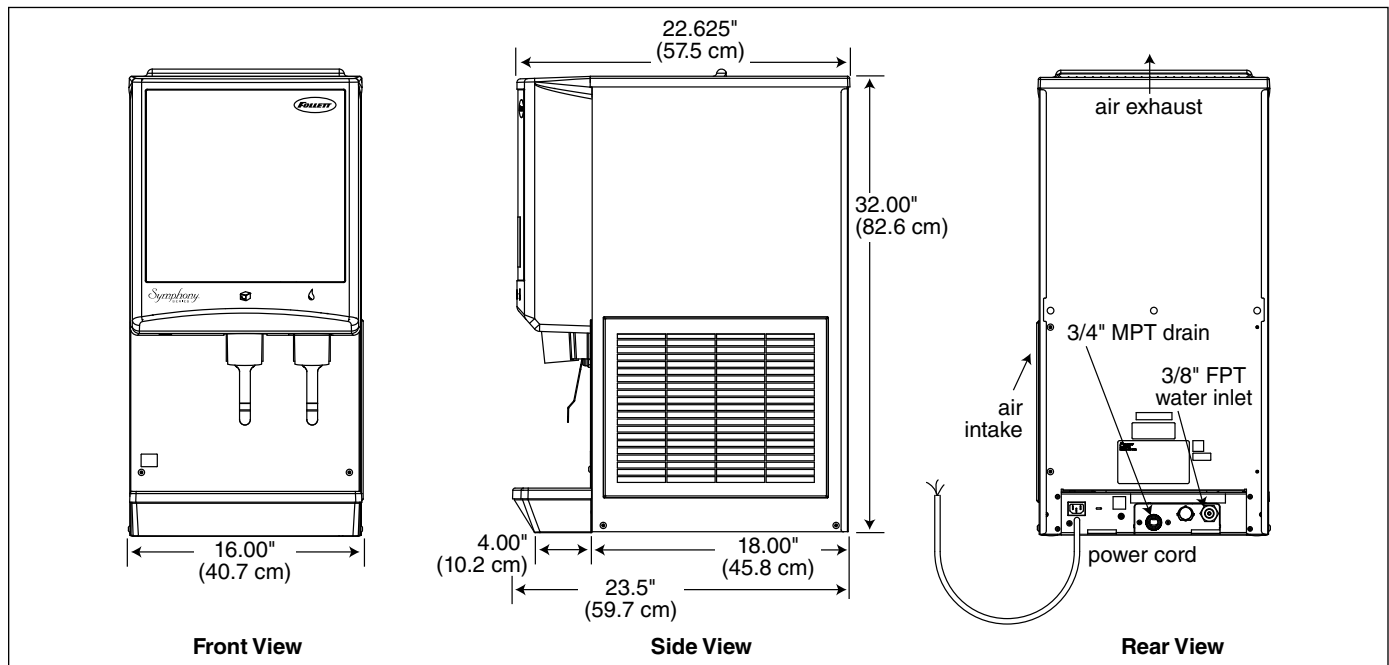

### Electrical

- 230 V, 50 Hz, 1 phase, 5.5A
- Connect to a dedicated circuit.

### Ambient

Air temp*	100 F/38 C Max.	50 F/10 C Min. Best performance below 80 F (27 C)
Water temp†	90 F/32 C Max.	45 F/4 C Min. Best performance below 70 F (21 C)
Water pressure	87 psig/0.6 MPa max.	10 psig/0.07 MPa min.

\* Ambient air temperature is measured at the air-cooled condenser coil inlet.

† Ambient water temperature is measured in the ice machine reservoir.

### Plumbing

	<b>E12CI414A</b>
Dispenser drain	3/4" MPT
Water inlet	3/8" FPT

**Note:** Water shut-off recommended within 10 ft. (3 m) of dispenser. Drain to be hard-piped and insulated. Maintain at least 1/4" per foot (20 mm per 1 m) run of slope.

### Ventilation clearances

- 6" (15.3 cm) on right side of dispenser, 6" (15.3 cm) at top for ventilation and 12" (30.5 cm) at top recommended for service.

**Note:** Do not block right side air intake or top air exhaust.

### Dry weight

- 144 lb (65 kg)

## Refrigeration pressure data

### Air-Cooled ice machine capacity/24hrs

Ambient Air Temperature F/C

	F	60	70	80	90	100	
	C	16	21	27	32	38	
Inlet Water Temperature F/C	50	418	388	357	325	294	lbs.
	10	189	176	162	147	179	kg.
	60	395	370	345	313	281	lbs.
	16	179	168	156	142	127	kg.
	70	372	353	334	301	268	lbs.
	21	169	160	151	137	122	kg.
	80	362	340	318	288	259	lbs.
	27	164	154	144	131	117	kg.
	90	352	327	302	275	249	lbs.
	32	160	148	137	125	113	kg.

## Compressor data

Air-cooled				
Ambient air temperature	50 F/10 C	70 F/21.1 C	90 F/32.2 C	110 F/43.3C
	230 V	230 V	230 V	230 V
Amperage	2.2	2.3	2.5	2.6
High-side pressure (PSIG)	112	152	202	260
Low-side pressure (PSIG)	18.5	21	25	30

Locked rotor amps: 230 V: 18.2A

## Gearmotor data

Gearmotor data	230 V/50 Hz
Gearmotor current	1.3A (nominal)

## Refrigeration system

### Ice machine charge specifications

Model	Charge	Refrigerant type
E12CI414A (air-cooled)	99 g (3.49 oz)	R290

# Installation

## Before you begin

- All dispensers must be installed level in both directions to ensure proper operation.
- Service and ventilation clearances: 6" (15.3 cm) on right side of dispenser, 6" (15.3 cm) at top for ventilation and 12" (30.5 cm) at top recommended for service.
- Countertop units installed without legs provide the option of taking utilities out bottom or back of dispenser (on wall mount units and countertop units with legs, utilities exit from back). See counter cutout drawings for bottom exiting utilities. For installations where utilities exit through back of dispenser, refer to back view drawings.
- If mounting above a sink, counter depth must allow front of sink to be a minimum of 30.00" (76.2 cm) from wall.

## Installing countertop dispensers without legs

1. Position dispenser in desired location, mark dispenser outline on counter and remove dispenser.
2. Regardless of whether utilities will exit through back or bottom of dispenser, drill four 7/16" holes in counter to anchor dispenser to counter (**Fig. 1**).
3. **For utilities exiting through bottom only:**
  - (a) Make cut out (**Fig. 1**).
  - (b) Move drain fitting from back of dispenser and mount (**Fig. 2**).
  - (c) Cut drain tube to length and attach to barbed connection.
  - (d) Move inlet water fitting from back of dispenser and mount (**Fig. 2**).
  - (e) Cut water tubing to length and re-insert into water fitting.
4. **For all units:** Apply a thick bead approximately 1/4" (7 mm) diameter of NSF-listed silicone sealant (Dow Corning RTV-732® or equivalent) 1/4" (7 mm) inside marked outline of dispenser.
5. Carefully lower dispenser on counter in proper position and secure to counter with four (4) 3/8"-16UNC bolts.
6. Smooth excess sealant around outside of dispenser.

Fig. 1

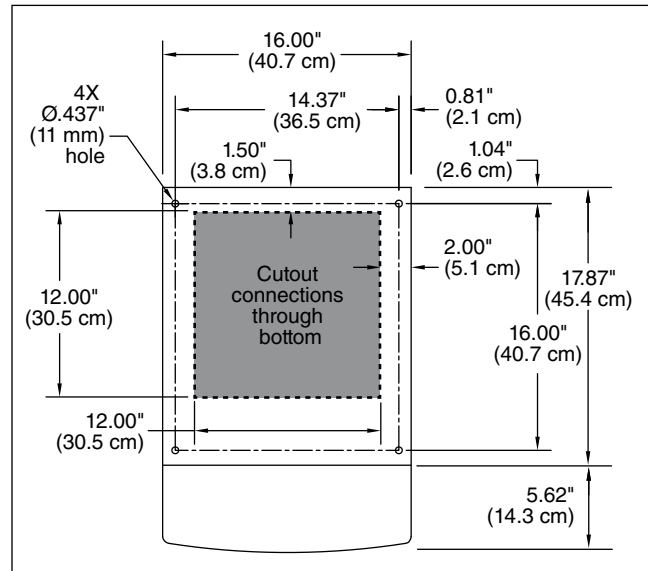
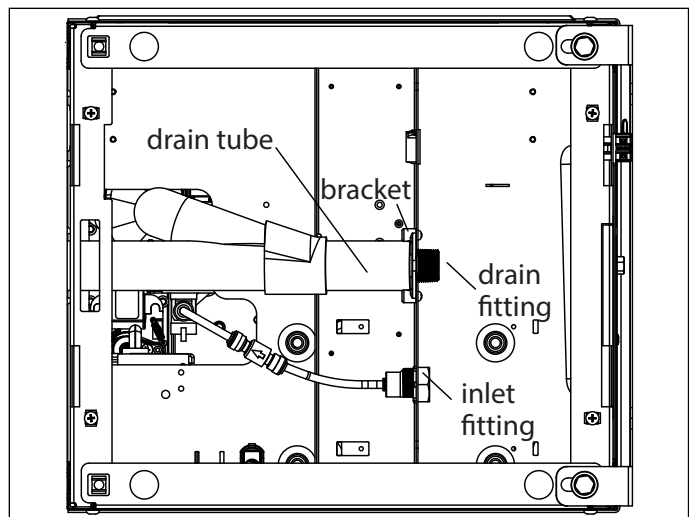

Fig. 2 - Bottom exiting utilities (countertop units)



## Installing countertop dispensers with legs accessory (P/N AF10LBLEGS)



### CAUTION!

- Do not tilt unit further than 30° off vertical plane.
- Countertop dispensers that sit on legs (not bolted to counter) can be inadvertently moved. Care should be taken when operating and cleaning to avoid accidents.

1. Carefully tip dispenser back to expose underside and block up in place.
2. Screw legs (shipped taped to drain pan of dispenser) into dispenser bottom, taking care to seat legs securely against underside of dispenser.
3. Attach bottom panel and hardware to bottom of dispenser with supplied screws (**Fig. 3**).
4. Position unit in desired location and adjust legs to level in both directions.
5. Make final connections.

**Fig. 3 - Bottom panel and leg assembly**

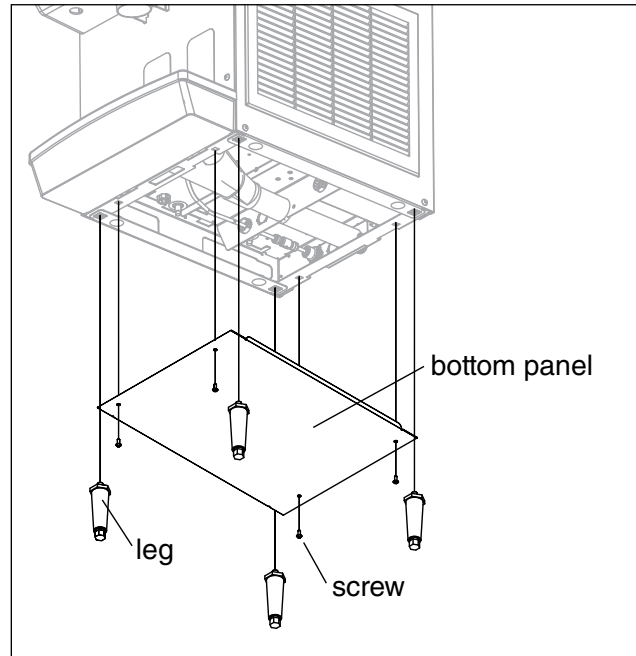

## Cleaning

Follett ice machines and dispensers, and their associated cleaning and sanitizing procedures, are designed for use with potable water sources. The presence, or suspected presence, of infectious agents may call for additional measures, including the replacement of components and more comprehensive disinfection measures. Follett recommends that these cleaning and sanitizing procedures be reviewed with the appropriate infectious agent subject matter experts to assure complete remediation.

Periodic cleaning of Follett's ice and water dispenser and ice machine system is required to ensure peak performance and delivery of clean, sanitary ice. The recommended cleaning procedures that follow should be performed at least as frequently as recommended and more often if environmental conditions dictate.

Cleaning of the condenser can usually be performed by facility personnel. Cleaning of the ice machine system should be performed by your facility's trained maintenance staff or a Follett authorized service agent. Regardless of who performs the cleaning, it is the operator's responsibility to see that this cleaning is performed according to the schedule below. Service problems resulting from lack of preventive maintenance will not be covered under the Follett warranty.

### Recommended cleaning intervals\*

Symphony Plus	Frequency
Drain Line	weekly
Drain Pan/Drip Pan	weekly
Exterior	as needed
Condenser	monthly (air-cooled only)
Dispenser and Components	semi-annually
Ice Machine	semi-annually
Transport Tube	semi-annually
Ice Storage Area/Bin	semi-annually

\* Ice machine and dispenser must be cleaned prior to start-up.

## Weekly

### CAUTION!

- Do not use solvents, abrasive cleaners, metal scrapers or sharp objects to clean any part of the dispenser.

### Dispenser drain pan and drain line

- Pour 1 gal. (3.8 L) of hot tap water into drain pan to flush drains.

### Splash panel front, SensorSAFE™ infrared dispensing

- Deactivate dispensing by pressing and releasing clean switch located on left side of unit under top front cover.
- Clean lens and splash panel front using a soft cloth and mild, non-abrasive, non-chlorine based cleaner.
- Reactivate dispensing by pressing and releasing clean switch again.

## Monthly

### CAUTION!

- Do not use solvents, abrasive cleaners, metal scrapers or sharp objects to clean any part of the dispenser.

### **Condenser (air-cooled ice machine only)**

- Use a vacuum cleaner or stiff brush to carefully clean condenser coils of lint and debris to ensure optimal performance.

### **Semi-Annually (more often if conditions dictate)**

- A cleaning procedure should always include both the ice machine and dispenser.
- Icemaking system can be cleaned in place.

### CAUTION!

- Wear rubber gloves and safety goggles (or face shield) when handling SafeCLEAN Plus.
- Use only Follett approved cleaners.
- Do not use solvents, abrasive cleaners, metal scrapers or sharp objects to clean any part of the dispenser.

## Cleaning tool checklist

- (1 or 2) 1.5 gallon (or larger) plastic bucket
- (2) clean cloths
- Sanitary gloves
- Safety glasses
- (2) SaniSponge™ (P/N 00131524 - single sponge)
- SafeCLEAN Plus ice machine cleaner

**SafeCLEAN Plus Solution:** Follow the directions on the SafeCLEAN Plus packaging to mix 1 gal. (3.8 L) of Follett SafeCLEAN Plus solution. Use 100 F (38 C) water.

## Ice Machine and Dispenser

### Cleaning procedure

**Note:** Check drains and drain cup to ensure they are open and flowing freely.

1. If ice machine was running recently, ensure that the evaporator is completely free of ice before proceeding. If there is ice in the evaporator, complete steps 2-7 using only hot water to remove the ice then begin Cleaning Procedure again.
2. Remove front cover and turn OFF bin signal switch.
3. Dispense all ice from storage hopper and discard.
4. Remove top of machine and hopper lid.
5. Press **CLEAN** switch. The **MAINTENANCE** light will turn on and the machine will drain. Wait for the **LOW WATER** light to turn on.
6. Remove lid from cleaning cup and fill (about 1 quart) until SafeCLEAN Plus solution overflows from the ice transport tube into the hopper. Place lid back on cup. Save remainder of SafeCLEAN Plus solution.
7. **CLEANER FULL** light will turn on and machine will start cleaning cycle then rinse three times; this process takes approximately 15 minutes.
8. While ice machine is cleaning, clean dispenser as follows:
  - a. Remove center thumbscrew, locking plate, two wingnuts and backing plate from front of storage hopper.
  - b. Remove stud assembly, baffle, wheel, and any remaining ice.
  - c. Remove dispense chutes from splash panel.
  - d. Submerge drain grille in SafeCLEAN Plus solution and allow to soak to remove any scale buildup.
  - e. Wipe inside of hopper lid, stud assembly, baffle, wheel, inside of storage area, dispense chutes, drain grille and drain pan with damp cloth wrung out in SafeCLEAN Plus solution. Thoroughly rinse all parts with damp cloth wrung out with clean water.

**Note:** To avoid possible damage to motor assembly, only use a damp cloth to clean storage hopper. Do not allow water to run through motor shaft hole in bottom of hopper.
9. When machine is finished cleaning, the **MAINTENANCE** light will turn off.
10. Reinstall dispense chutes, wheel, baffle, stud assembly and knurled nuts.
11. Remove top bearing insulation. Loosen Phillips-head screw on nozzle connected to evaporator. Remove nozzle from evaporator side only, leave other side of nozzle connected to transport tube.
12. Soak one SaniSponge in remaining SafeCLEAN Plus solution.
13. Insert the sponge soaked in SafeCLEAN Plus solution into nozzle then insert a dry sponge into the nozzle.

14. Replace nozzle onto evaporator and tighten screw. Ensure drain is connected to reservoir and vent tubes are connected to evaporator drain pan. Replace top bearing insulation.
15. Turn ON bin signal switch. Wait for ice to push sponges through transport tube.
16. Collect sponges from ice storage bin.
17. Replace hopper lid, machine top, and install front cover.
18. After 10 minutes, dispense all ice and discard.

### User Interface and Exterior Cabinet

- Clean stainless steel panels with stainless steel cleaner.

### Electrical system



#### ATTENTION!

To prevent circuit breaker overload, wait 15 minutes before restarting this unit. This allows the compressor to equalize and the evaporator to thaw.

### Normal control board operation

The PC board indicator lights provide all the information necessary to determine the machine's status. Green indicator lights generally represent “go” or normal operation; Yellow indicators represent normal off conditions; Red indicators generally represent alarm conditions, some of which will lock the machine off.

A flashing green light labeled POWER indicates power to the machine. All other normal operation status indicators are covered as follows:

Ice machine disposition	Operating conditions
<b>Legend:</b> ● ON    ○ OFF    ◐ ON or OFF    ◑ FLASHING	
1. Ice machine is making ice.  CLEANER FULL ○ DRAIN CLOG ○ HI PRESS ○ HI AMPS ○ SERVICE ○ MAINT/CLEAN ○ LOW WATER ○ TIME DELAY ○ SLEEP CYCLE ○ MAKING ICE ● LOW BIN ● POWER ON ◑	1. <b>Normal running.</b>
2. Ice machine is not making ice.  CLEANER FULL ○ DRAIN CLOG ○ HI PRESS ○ HI AMPS ○ SERVICE ○ MAINT/CLEAN ○ LOW WATER ● TIME DELAY ○ SLEEP CYCLE ○ MAKING ICE ○ LOW BIN ◐ POWER ON ◑	2. <b>Normal time delay.</b> When the bin fills with ice, the LOW BIN light goes out momentarily and the refrigeration and auger drive systems immediately shut down. ( <b>Note:</b> The fan motor will continue to run for 10 minutes to cool condenser) The TIME DELAY light comes on, initiating the time delay period. When the time delay expires, the machine will restart provided that the LOW BIN light is on.

### Control board DIP switch settings

OFF POSITION     ON POSITION

#### Symphony Plus 12/25/50 CI, HI, or FB; E12CI

	OFF	ON	
MUST be set to off	<input checked="" type="checkbox"/>	<input type="checkbox"/>	MUST be set to off
Sleep cycle disabled	<input type="checkbox"/>	<input checked="" type="checkbox"/>	Sleep cycle enabled
SensorSAFE*	<input type="checkbox"/>	<input checked="" type="checkbox"/>	Lever*
Sleep cycle	<input type="checkbox"/>	<input checked="" type="checkbox"/>	Sleep cycle
[dispense duration]	<input type="checkbox"/>	<input checked="" type="checkbox"/>	[dispense duration]
20 min. time delay	<input type="checkbox"/>	<input checked="" type="checkbox"/>	60 min. time delay
Flush disabled	<input type="checkbox"/>	<input checked="" type="checkbox"/>	Flush enabled
Maint. timer ON	<input type="checkbox"/>	<input checked="" type="checkbox"/>	Maint. timer OFF

#### Sleep cycle dispense duration

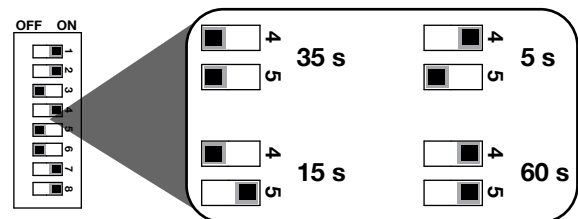

\* Set according to application.

# Wiring diagram - 230 V 50 Hz

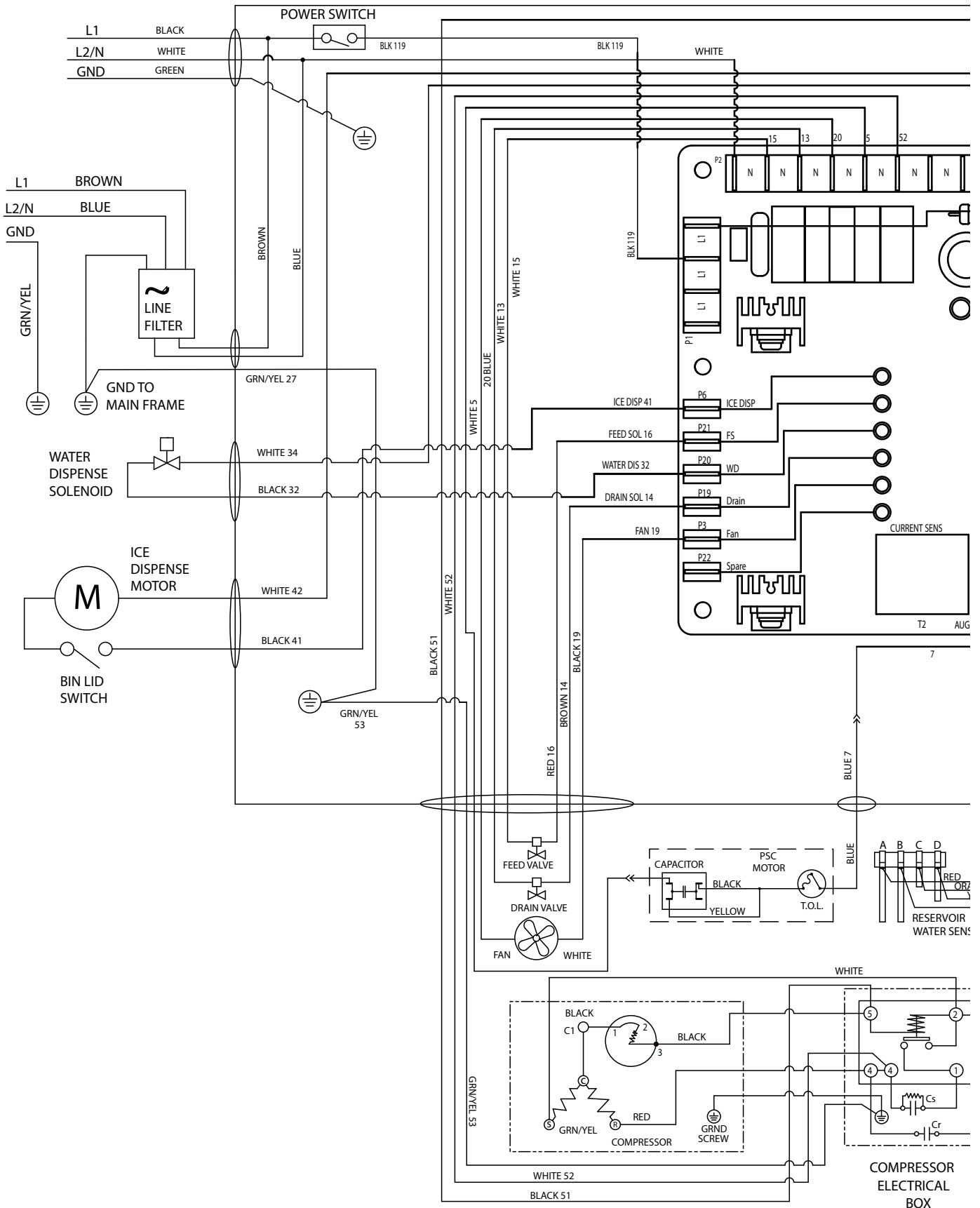

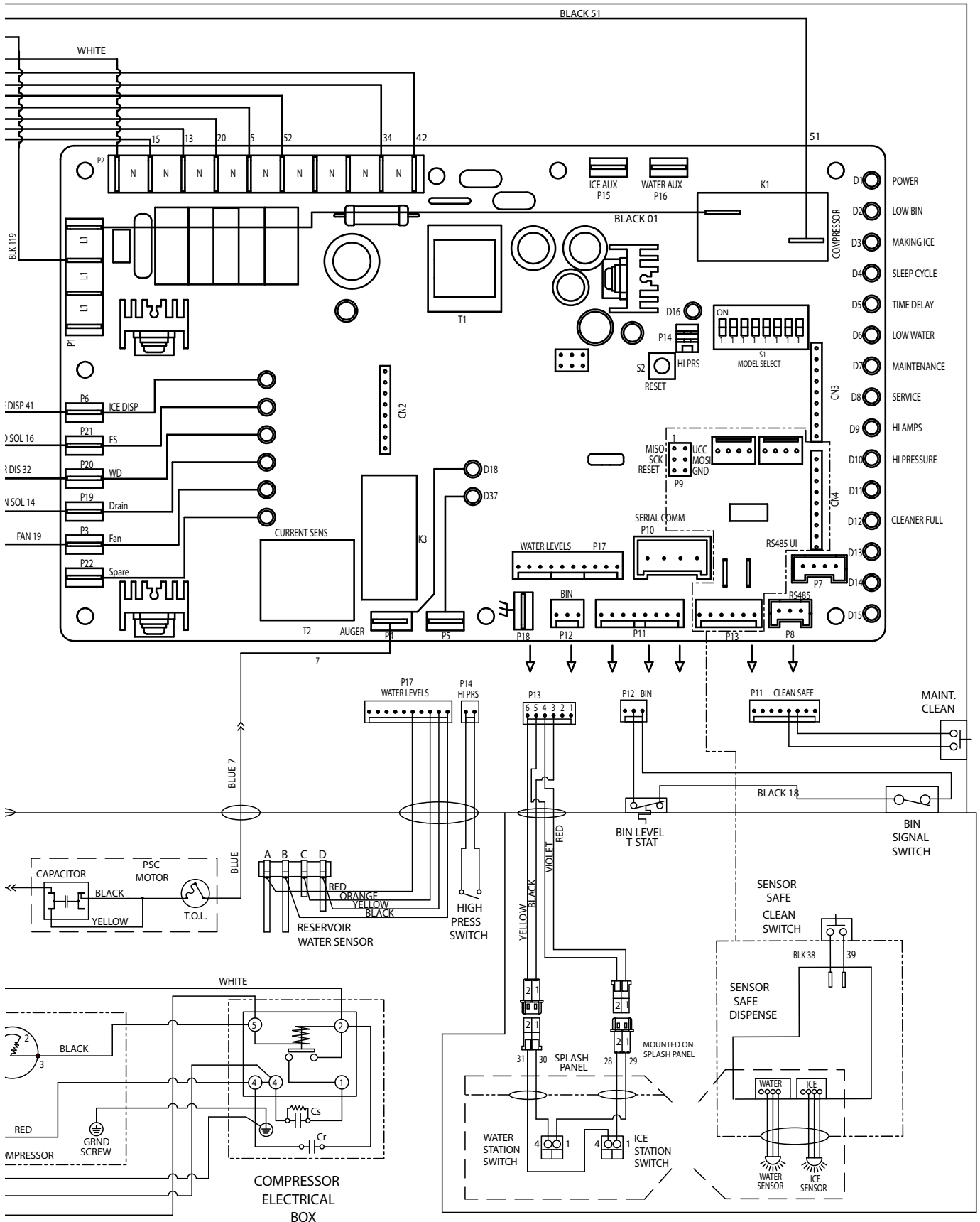

## Dispenser troubleshooting



- Disconnect power to unit before putting hands or arms in storage area or attempting any repair or service to equipment.

### Before calling for service

1. Check that no ice is in the dispenser bin area.
2. Check that congealed ice is not causing a jam.
3. Check that all switches and circuit breakers are on.
4. Check that all drains are clear.
5. Check that water is supplied.

### Lever model troubleshooting guide

Problem	Indicators	Corrective Action
Does not dispense ice.	<ol style="list-style-type: none"> <li>1. Power switch off or faulty.</li> <li>2. Faulty dispense switch.</li> <li>3. Wheel motor malfunction.</li> <li>4. Defective control board.</li> <li>5. Defective wiring.</li> </ol>	<ol style="list-style-type: none"> <li>1. Turn on or replace the defective switch.</li> <li>2. Replace defective switch.</li> <li>3. Verify voltage at motor and replace wheel motor if defective.</li> <li>4. Jumper pins 1 &amp; 2 on connector P13.               <ol style="list-style-type: none"> <li>a. Control board output LED, D19 should light. Replace board, if D19 does not come on.</li> <li>b. D19 comes on but no voltage at wheel motor. Move connector from P6 to L1, if motor runs, replace control board.</li> </ol> </li> <li>5. Ohm check wiring going from lever switch to P13 pins 1 &amp; 2. Ohm check wiring from P6 to wheel motor and neutral wire to neutral on control board. Repair or replace as needed.</li> </ol>
Dispense wheel rotates continuously.	Dispense switch contacts are welded together.	Replace dispense switch.
Ice machine runs continuously.	Faulty or incorrectly positioned bin thermostat.	Check for proper positioning. If thermostat does not open when ice is placed on capillary tube, replace thermostat.
Does not dispense water.	<ol style="list-style-type: none"> <li>1. Power switch off/faulty.</li> <li>2. Faulty water dispense switch.</li> <li>3. Water dispense solenoid malfunction.</li> <li>4. Defective control board.</li> <li>5. Defective wiring.</li> </ol>	<ol style="list-style-type: none"> <li>1. Turn on or replace the defective switch.</li> <li>2. Replace defective switch.</li> <li>3. Verify voltage at water dispense solenoid and replace water dispense solenoid if defective.</li> <li>4. Jumper pins 3 &amp; 4 on connector P13.               <ol style="list-style-type: none"> <li>a. Control board output LED, D21 should light. Replace board, if D21 does not come on.</li> <li>b. D21 comes on but no voltage at wheel motor. Move connector from P20 to L1, if motor runs, replace control board.</li> </ol> </li> <li>5. Ohm check wiring going from lever switch to P13 pins 3 &amp; 4. Ohm check wiring from P20 to wheel motor and neutral wire to neutral on control board. Repair or replace as needed.</li> </ol>

## SensorSAFE model troubleshooting guide

Problem	Indicators	Corrective Action
Does not dispense ice.	<ol style="list-style-type: none"> <li>1. Power switch off or faulty.</li> <li>2. Power on but no ice dispensing</li> <li>3. Faulty ice dispense sensor.</li> <li>4. Wheel motor malfunction.</li> <li>5. Defective control board/ daughter card.</li> <li>6. Defective wiring.</li> </ol>	<ol style="list-style-type: none"> <li>1. Turn on or replace the defective switch.</li> <li>2. Verify daughter card is properly aligned and inserted with pins on the control card and bin lid jumper is installed.</li> <li>3. Follow the steps below for ice dispensing.               <ol style="list-style-type: none"> <li>a. If ice and water dispenser, switch connectors going from sensors to daughter and if problem follows to opposite input, replace defective sensor.</li> <li>b. Once switched, if problem stays with same input, jumper pins 3 &amp; 4 on daughter card ice connector and the control board output LED, D19 should light. Replace board, if D19 does not come .</li> </ol> </li> <li>4. Verify 120 vac at motor and replace wheel motor if defective.</li> <li>5. D19 comes on but no voltage at wheel motor. Move connector from P6 to L1, if motor runs, replace control board.</li> <li>6. Ohm check wiring from P6 to wheel motor and neutral wire to neutral on control board. Repair or replace as needed.</li> </ol>
Does not dispense water	<ol style="list-style-type: none"> <li>1. Power switch off/faulty.</li> <li>2. Faulty water dispense sensor.</li> <li>3. Water dispense solenoid malfunction or defective control board/daughter card.</li> <li>4. Defective wiring.</li> </ol>	<ol style="list-style-type: none"> <li>1. Turn on or replace the defective switch.</li> <li>2. Follow the steps below for water dispensing.               <ol style="list-style-type: none"> <li>a. If ice and water dispenser, switch connectors going from sensors to daughter and if problem follows to opposite input, replace defective sensor.</li> <li>b. Once switched, if problem stays with same input, jumper pins 3 &amp; 4 on daughter card water connector and the control board output LED, D21 should light. Replace control board/daughter card, if D21 does not come on. If D21 comes on, move connector from P20 to L1, if solenoid energizes, replace control board.</li> </ol> </li> <li>3. Verify 120 VAC at solenoid and replace if present.</li> <li>4. Ohm check wiring going from water solenoid to P20 terminal on control board. Ohm check wiring from water solenoid neutral wire to neutral on control board. Repair or replace as needed.</li> </ol>
Ice machine runs continuously.	Faulty or incorrectly positioned bin thermostat.	Check for proper positioning. If thermostat does not open when ice is placed on capillary tube, replace bin thermostat.

## Warranty Registration and Equipment Evaluation

Thank you for purchasing Follett® equipment. Our goal is to deliver high value products and services that earn your complete satisfaction by delivering high-value products and services backed by outstanding customer and technical support.

Please review the installation instructions thoroughly. It is important that the installation be performed to factory specifications so your equipment operates at its maximum efficiency.

Follett LLC will not be liable for any consequential damages, expenses, connecting or disconnecting charges, or any losses resulting from a defect of the machine. For full warranty details, visit our website [www.follettice.com/productwarranties](http://www.follettice.com/productwarranties).

Registering your equipments helps Follett track your equipment's service history should you need to contact us for technical support, and your feedback helps us improve our products and services. Please visit [www.follettice.com/support](http://www.follettice.com/support) to complete the Warranty Registration form.

Should you have any questions, please contact Follett's technical support group at (877) 612-5086 or (610) 252-7301 and we will be happy to assist you.

Dow Corning is a registered trademark of Dow Corning Corporation in the United States and other countries.  
SafeCLEAN, SaniSponge, SensorSAFE, and Symphony Plus are trademarks of Follett Products, LLC.  
Follett is a registered trademarks of Follett Products, LLC, registered in US.



801 Church Lane • Easton, PA 18040, USA  
Toll free (877) 612-5086 • +1 (610) 252-7301  
[www.follettice.com](http://www.follettice.com)

Follett Europe Polska Sp. z o.o.  
Mokry Dwór 26 c • 83-021 Wiślina, Poland  
+48 (58) 785-6140 • Fax +48 (58) 785-6159  
[www.folletteurope.com](http://www.folletteurope.com)

01518968R06

© Follett Products, LLC 2/25