

Refrigerator and freezer accessories

single door and double door uprights

Item# 01059484 – REF12i

Item# 01548809 – REF20i/FZR20i

Item# 01548817 – REF25i/FZR25i



Additional shelf for Infinity Series™ REF12i, REF20i and REF25i refrigerators and FZR20i and FZR25i freezers

- includes 1 epoxy-coated wire shelf
- item# 01059484 – REF12i
 - shelf dimensions – 18.10" W x 15.10" D (46.0 x 38.4 cm)
 - shipping dimensions – 20.00" x 18.00" x 5.00" (50.8 x 44.7 x 12.7 cm)
 - shipping weight – 5 lb (2.3 kg)
- item# 01548809 – REF20i/FZR20i
 - shelf dimensions – 22.20" W x 18.50" D (56.4 x 47.0 cm)
 - shipping dimensions – 29.50" x 23.50" x 7.50" (74.9 x 59.7 x 19.0 cm)
 - shipping weight – 9 lb (4 kg)
- item# 01548817 – REF25i/FZR25i
 - shelf dimensions – 22.20" W x 24.40" D (56.4 x 62.0 cm)
 - shipping dimensions – 29.50" x 23.50" x 7.50" (74.9 x 59.7 x 19.0 cm)
 - shipping weight – 11 lb (5 kg)

Item# 01311976



Additional shelf for REF12-LB refrigerators

1/2" (1.27 cm) spacing between shelving with the use of support clips.
Maximum of 6 shelves per unit.

- includes 1 epoxy-coated wire shelf and 4 clips
- shelf dimensions – 18.00" W x 19.00" D (45.7 x 48.3 cm)
- shipping dimensions – 24.00" x 24.00" x 4.00" (61.0 x 61.0 x 10.2 cm)
- shipping weight – 6 lb (2.7 kg)

Item# 00927251 – REF20-LB, FZR20-LB

Item# 00927269 – REF25-LB, REF45-LB, FZR25-LB



Additional shelves for REF20-LB, REF25-LB and REF45-LB refrigerators and FZR20-LB and FZR25-LB freezers¹

1/2" (1.27 cm) spacing between shelving with the use of support clips.

- includes 2 epoxy-coated wire shelves and 8 clips
- item# 00927251 – REF20-LB and FZR20-LB
 - shelf dimensions – 23.38" W x 19.50" D (59.4 x 49.5 cm)
 - shipping dimensions – 24.00" x 24.00" x 7.00" (61.0 x 61.0 x 17.8 cm)
 - shipping weight – 16 lb (7 kg)
- item# 00927269 – REF25-LB, REF45-LB and FZR25-LB
 - shelf dimensions – 23.38" W x 25.50" D (59.4 x 64.8 cm)
 - shipping dimensions – 30.00" x 29.00" x 8.00" (73.2 x 73.7 x 20.3 cm)
 - shipping weight – 18 lb (8 kg)

¹ Not for use with REFVAC20/REFVAC25-LB, REFVAC45-LB or FZRVAC20/FZRVAC25-LB.

Item# 01461268 – REFVAC20-LB, FZRVAC20-LB

**Item# 01460708 – REFVAC25-LB, REFVAC45-LB,
FZRVAC25-LB**



Additional shelf for REFVAC20, REFVAC25-LB and REFVAC45-LB refrigerators and FZRVAC20-LB and FZRVAC25-LB freezers¹

1/2" (1.27 cm) spacing between shelving.

- includes 1 epoxy-coated wire shelf and 4 clips
- item# 01461268 – REFVAC20-LB and FZRVAC20-LB
 - shelf dimensions – 21.75" W x 19.25" D (55.2 x 48.9 cm)
 - shipping dimensions – 30.00" x 24.00" x 8.00" (76.2 x 61.0 x 20.3 cm)
 - shipping weight – 14 lb (6 kg)
- item# 01460708 – REFVAC25-LB, REFVAC45-LB and FZRVAC25-LB
 - shelf dimensions – 21.75" W x 24.19" D (55.2 x 64.1 cm)
 - shipping dimensions – 30.00" x 24.00" x 8.00" (76.2 x 61.0 x 20.3 cm)
 - shipping weight – 14 lb (6 kg)

¹ Not for use with REF20/REF25-LB, REF45-LB or FZR20/FZR25-LB.

Item# 01543925 – REF12i

Item# 01548825 – REF20i

Item# 01548833 – REF25i



Additional basket for Infinity Series REF12i, REF20i and REF25i refrigerators

- includes 1 basket, 8 rollers, 4 screws and nuts and 2 slides
- item# 01543925 – REF12i
 - basket dimensions – 17.10" x 16.40" x 6.00" (43.4 x 41.7 x 15.2 cm)
 - shipping dimensions – 24.00" x 24.00" x 7.00" (61.0 x 61.0 x 17.8 cm)
 - shipping weight – 11 lb (5 kg)
- item# 01548825 – REF20i
 - basket dimensions – 21.75" x 19.25" x 5.88" (55.2 x 48.9 x 14.9 cm)
 - shipping dimensions – 30.00" x 24.00" x 8.00" (76.2 x 61.0 x 20.3 cm)
 - shipping weight – 14 lb (6 kg)
- item# 01548833 – REF25i
 - basket dimensions – 21.75" x 24.19" x 5.88" (55.2 x 61.4 x 14.9 cm)
 - shipping dimensions – 30.00" x 24.00" x 8.00" (76.2 x 61.0 x 20.3 cm)
 - shipping weight – 14 lb (6 kg)

Item# 01543933 – REF12i

Item# 01548841 – REF20i

Item# 01548858 – REF25i

Item# 01554492 – FZR20i

Item# 01554500 – FZR25i



Additional drawer for Infinity Series REF12i, REF20i and REF25i refrigerators and FZR20i and FZR25i freezers

- includes 1 drawer, 8 rollers, 4 screws and nuts and 2 slides
- item# 01543933 – REF12i
 - drawer dimensions – 14.63" x 17.82 x 3.00" (37.2 x 44.8 x 7.62 cm)
 - shipping dimensions – 24.00" x 24.00" x 7.00" (61.0 x 61.0 x 17.8 cm)
 - shipping weight – 12 lb (5.4 kg)
- item# 01548841 – REF20i
 - drawer dimensions – 22.50" x 19.94" x 3.00" (57.2 x 50.6 x 7.62 cm)
 - shipping dimensions – 30.00" X 24.00" X 8.00" (76.2 X 61.0 X 20.3 cm)
 - shipping weight – 17 lb (8 kg)
- item# 01548858 – REF25i
 - drawer dimensions – 22.50" x 25.94" x 3.00" (57.2 x 65.4 x 7.62 cm)
 - shipping dimensions – 30.00" x 24.00" x 8.00" (76.2 x 61.0 x 20.3 cm)
 - shipping weight – 21 lb (10 kg)
- item# 01554492 – FZR20i
 - drawer dimensions – 22.50" x 19.94" x 3.00" (57.2 x 50.6 x 7.62 cm)
 - shipping dimensions – 30.00" x 24.00" x 8.00" (76.2 x 61.0 x 20.3 cm)
 - shipping weight – 17 lb (8 kg)
- item# 01554500 – FZR25i
 - drawer dimensions – 22.50" x 25.94" x 3.00" (57.2 x 65.4 x 7.62 cm)
 - shipping dimensions – 30.00" x 24.00" x 8.00" (76.2 x 61.0 x 20.3 cm)
 - shipping weight – 21 lb (10 kg)

Item# 01140458 – REF20/25, REFVAC20/25, REF45/REFVAC45 before serial number Q86639 FZR20/25, FZRVAC20/25



Item# 01540640 – REF45/REFVAC45 after serial number Q86638 and Infinity Series (not shown)

Quick-connect replacement RTD temperature probe with certificate of NIST-traceable calibration

The temperature probe monitors the interior temperature conditions of a refrigerator or freezer to ensure proper display and alarming.

- certificate of NIST-traceable calibration
- bottle not included
- shipping dimensions – 5.00" x 5.00" x 8.00" (12.7 x 12.7 x 20.3 cm)
- shipping weight – 1 lb (0.5 kg)

Item# 00927202 – Pyxis®

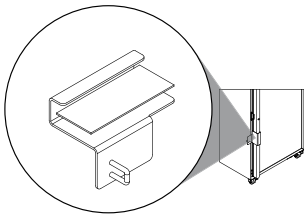

Medication dispensing system compatible door brackets

Brackets allow medication dispensing system locking devices to be securely installed onto Follett upright refrigerators and freezers.

- item# 00927202 – Pyxis®
 - clearance required for lock box – 2.50" (6.35 cm) on handle side
 - shipping dimensions – 11.00" x 9.00" x 7.00" (27.9 x 22.9 x 17.8 cm)
 - shipping weight – 3 lb (1 kg)
- item# 00966432 – Omnicell®
 - clearance required for lock box – 4.00" (10.16 cm)
 - shipping dimensions – 19.00" x 11.00" x 8.00" (48.3 x 27.9 x 20.3 cm)
 - shipping weight – 7 lb (3 kg)
- item# 00978296 – medDISPENSE®
 - clearance required for lock box – 4.00" (10.16 cm)
 - shipping dimensions – 16.00" x 13.00" x 7.00" (40.6 x 33.0 x 17.8 cm)
 - shipping weight – 7 lb (3 kg)

Item# 00966432 – Omnicell®

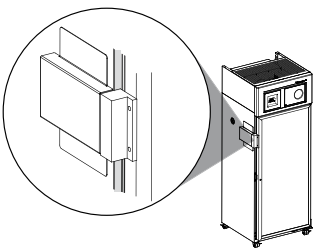

Item# 00978296 – medDISPENSE®

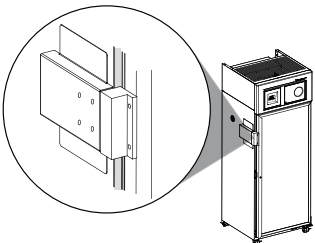

Item# 00959296



Glycerine

Solution, used as a buffering agent, to stabilize temperature probe reading for the most accurate temperature display.

- 16 oz bottle
- shipping dimensions – 11.00" x 9.00" x 7.00" (27.9 x 22.9 x 17.8 cm)
- shipping weight – 2 lb (0.9 kg)

Item# 01543883

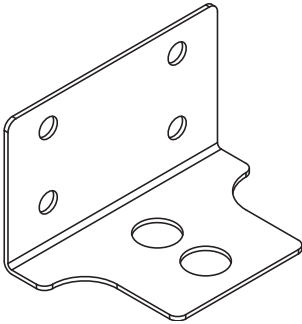

Seismic anchoring kit for Infinity Series REF12i refrigerators

Designed to secure REF12i upright refrigerators to the wall.

- shipping dimensions – 11.00" x 9.00" x 7.00" (27.9 x 22.9 x 17.8 cm)
- shipping weight – 2 lb (0.9 kg)

Item# 01319441

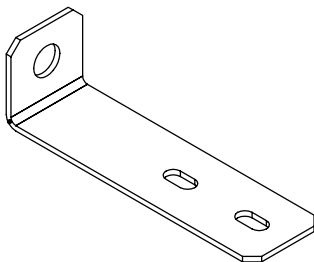

Seismic anchoring kit for REF12-LB refrigerators

Designed to secure REF12-LB upright refrigerators to the wall.

- shipping dimensions – 4.00" x 4.00" x 9.00" (10.2 x 10.2 x 22.9 cm)
- shipping weight – 2 lb (0.9 kg)

Item# 00927194

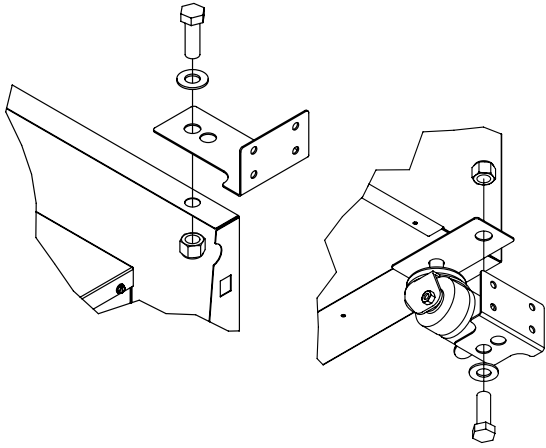

Seismic anchoring kit for REF20i and REF25i refrigerators and all REF/FZR20/25/45 refrigerators and freezers

Designed to secure all upright refrigerators and freezers (except REF12 models) to the wall.

- includes mounting plate, metal brackets and hardware
- certificate contains specific information to assure compliance with 2013 CBC and 2016 CBC
- shipping dimensions – 11.00" x 9.00" x 7.00" (27.9 x 22.9 x 17.8 cm)
- shipping weight – 3 lb (2 kg)

Item# 01548791

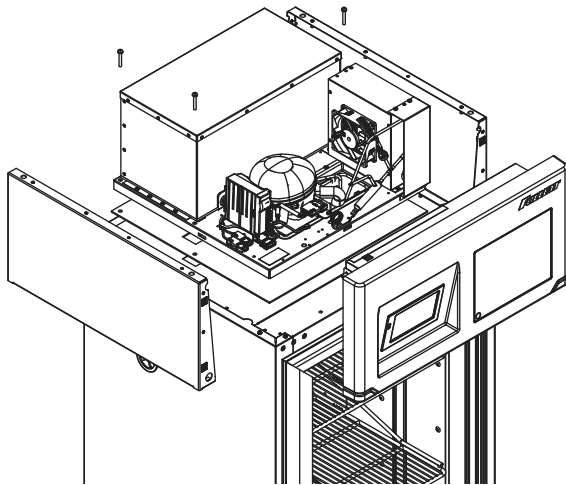

Replacement CRS (complete refrigeration system) module for Infinity Series REF12i, REF20i and REF25i refrigerators

Allows refrigeration system to be removed and replaced as a single unit.

- shipping dimensions – 31.00" x 27.00" x 23.00" (78.7 x 68.6 x 58.4 cm)
- shipping weight – 92 lb (42 kg)

Item# 01312529

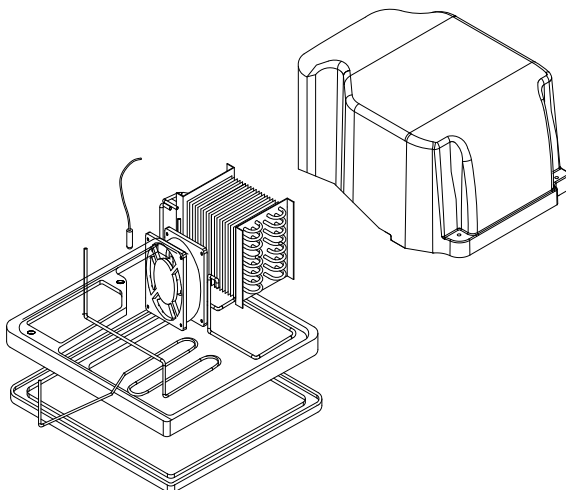

Replacement CRS (complete refrigeration system) module for REF12-LB refrigerators

Allows refrigeration system to be removed and replaced as a single unit.

- shipping dimensions – 29.00" x 29.00" x 27.00" (73.7 x 83.7 x 68.6 cm)
- shipping weight – 66 lb (30 kg)

Item# 01550870

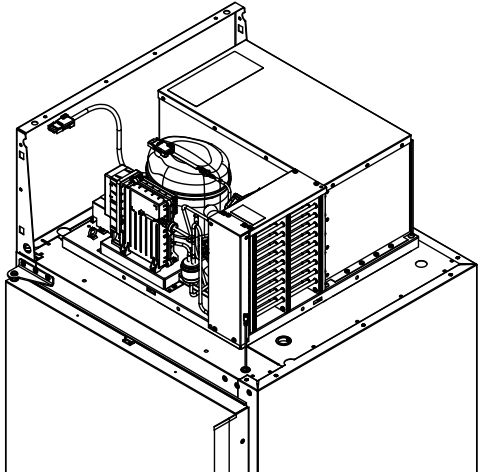

Replacement CRS (complete refrigeration system) module for Infinity Series FZR20i and FZR25i freezers

Allows refrigeration system to be removed and replaced as a single unit.

- 2 years parts, 5 years compressor parts, 2 years labor warranty
- shipping dimensions – 31.00" x 27.00" x 23.00" (78.7 x 68.6 x 58.4 cm)
- shipping weight – 110 lb (50 kg)

Item# 01147891

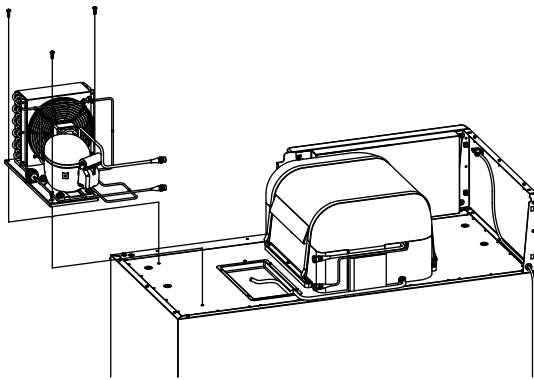

Replacement high-side refrigeration module (complete condensing unit) for REF45

- shipping dimensions – 30.00" x 33.00" x 33.00" (76.2 x 83.8 x 83.8 cm)
- shipping weight – 77 lb (35 kg)

Item# 01528512

DWE-VFC data logger

Dickson VFC-compliant display data logger with Wi-Fi or Ethernet capability. Ships with glycol thermistor sensor and a 1-Point NIST calibration.

- includes data logger, probe, certificate of calibration, and USB cable (subscription sold separately, contact Dickson for pricing)
- alarm type – text, email, phone call, audio, and visual
- local storage of 400,000 sample points
- AC powered with rechargeable battery backup (one week of backup power)
- one sensor port
- VFC/CDC compliant
- dimensions – 1.70" x 4.25" x 4.25" (4.3 x 10.8 x 10.8 cm)
- shipping dimensions – 8.00" x 5.00" x 5.00" (20.3 x 12.7 x 12.7 cm)
- shipping weight – 4 lb (1.8 kg)

Item# 01528538

TWP-VFC data logger

Dickson VFC-compliant display data logger with Power Over Ethernet or Wi-Fi capability. Ships with glycol thermistor sensor and a 1-Point NIST calibration.

- includes: data logger, probe, certificate of calibration, and USB cable (subscription sold separately, contact Dickson for pricing)
- alarm type – text, email, phone call, audio/visual
- local storage of 1 million sample points
- AC powered with rechargeable battery backup (70 hours of backup power)
- two sensor ports
- LCD touchscreen
- VFC/CDC compliant
- dimensions – 8.50" x 1.75" x 7.00" (21.0 x 4.5 x 18.0 cm)
- shipping dimensions – 11.00" x 9.00" x 9.00" (28.0 x 22.9 x 22.9 cm)
- shipping weight – 4 lb (1.8 kg)

Item# 01539691

Ambient temperature and humidity sensor

Dickson ambient temperature and humidity sensor (right angle) is perfect for monitoring clean rooms and more.

- temperature accuracy +/-0.8 F from 20.0 to 122.0 F 1.8 F (+/-0.4 C from -6.7 to 50.0 C 1.0 C)
- temperature range -40.0 to 185.0 F (-40.0 to 85.0 C)
- humidity accuracy +/-2.0% RH from 5.0 to 95.0% RH
- shipping dimensions – 8.00" x 5.00" x 5.00" (20.3 x 12.7 x 12.7 cm)
- shipping weight – 3 lb (1.4 kg)

Omnicell is a registered trademark of Omnicell, Inc. in the United States.
Pyxis is a registered trademark of CareFusion in the United States and other countries.
medDISPENSE is a registered trademark of InterMetro Industries Corp. in the United States and other countries.
INFINITY SERIES is a trademark of Follett Products, LLC.
FOLLETT and FOLLETT HEALTHCARE are registered trademarks of Follett Products, LLC, registered in the US.
Follett reserves the right to change specifications at any time without obligation.