



Horizon Elite™

remote 1810, 2110 series Chewblet® ice machine

Features

High performance Horizon Elite ice machines

- automatically transport ice through a tube with RIDE® technology from up to 75' (22.9 m) away
- consumer-preferred Chewblet ice is preferred 2:1 over cube ice
- ice dispenses reliably from ice and beverage dispensers
- quiet production without noisy harvest cycles

Revolutionary, scale inhibiting design

- produces ice that has 15% the TDS of the incoming water for optimum dispensing and long life in drinks
- quarantines and regularly expels scale producing dissolved solids to dramatically reduce scale buildup
- increases time between descaling and reduces or eliminates the need for expensive scale treatment
- uses 35% less water than comparable cubers
- contact Follett for ENERGY STAR® certified models

Durable, attractive ice machine

- regular bearing inspection or replacement is not required
- upgraded, easy-to-read LED operating status and diagnostic display

Designed with sanitation in mind

- Agion® silver-based antimicrobial product protection of key ice and water contact components¹
- floatless, sealed design inhibits formation of biofilms
- semi-automatic cleaning and sanitizing system

Remote monitoring with Open Kitchen™

- provided in partnership with Powerhouse Dynamics (separate subscription required)
- real-time alerts and notifications
- remote diagnostics to maximize equipment uptime
- connects with equipment across other Middleby brands

Warranty

- 3 years parts and labor, 5 years compressor parts²

Certifications (applied to all products unless otherwise noted)



Model configurations			
Production capacity	Description	V/Hz/Ph	Item number
up to 1784 lb (810 kg)	evaporator unit for connection to remote condenser 01571173 or 01571181	115/60/1	D1810R
	air-cooled, single phase remote condenser for use with D1810R evaporator unit. Pre-charged.	208-230/60/1	01571173
	air-cooled, three phase remote condenser for use with D1810R evaporator unit. Pre-charged.	208-230/60/3	01571181
up to 2039 lb (926 kg)	evaporator unit for connection to remote condenser 01571199 or 01571207	115/60/1	D2110R
	air-cooled, single phase remote condenser for use with D2110R evaporator unit. Pre-charged.	208-230/60/1	01571199
	air-cooled, three phase remote condenser for use with D2110R evaporator unit. Pre-charged.	208-230/60/3	01571207

Installation kits (required) ³			
Description	Ship wt lb (kg)	Item number	
Installation kit for filling ice storage bins	10 (5)	01564590	
Installation kit for filling countertop ice and beverage dispensers	10 (5)	01564582	
Installation kit for filling Vision™ dispensers	10 (5)	01564632	
Installation kit for filling drop-in dispensers	10 (5)	01564640	
Installation kit for Ice Manager™ not required. Needed components are ordered and ship with Ice Manager, see form# 1050.	N/A	N/A	

Ice transport tube kits for RIDE installations (required), not needed for top mount applications ³			
Description	Ship wt lb (kg)	Item number	
For bins, countertop ice and beverage dispensers and drop-in dispensers			
RIDE installations, 10' (3 m)	10 (5)	01560549	
RIDE installations, 35' (10.7 m)	22 (10)	01560556	
RIDE installations, 80' (24.4 m)	60 (27)	01560564	
For Vision dispensers			
RIDE installations, 10' (3 m)	10 (5)	01564657	
RIDE installations, 35' (10.7 m)	22 (10)	01564665	
RIDE installations, 80' (24.4 m)	60 (27)	01564673	

Options and accessories⁴

- Top kit for ice and beverage dispensers (page 5)
- Wall mount bracket (item# 00997098)
- Ice machine stand, height-adjustable (item# 00997080)
- Timer to control one or two ice machines (item# 00967265)
- Sleep cycle kit for countertop dispenser applications for improved energy efficiency and component life (item# 01338276)
- 35' (11 m) Insulated refrigeration lines (not pre-charged) (item# 00977785)
- One-year remote monitoring subscription and hardware for Open Kitchen (item# MDD-1003)
- Water filters (refer to form# 1058)
- SafeCLEAN Plus™ ice machine cleaner (refer to form# 8295)
- Additional accessories (refer to form# 4025)

¹ Disclaimer: Antimicrobial protection is limited to the treated components and does not treat water or ice.

² Refer to form# 4025 for additional warranty information.

³ Certifications do not apply to installation kits or ice transport tube kits.

⁴ Certifications do not apply to options and accessories.

Dimensional drawing

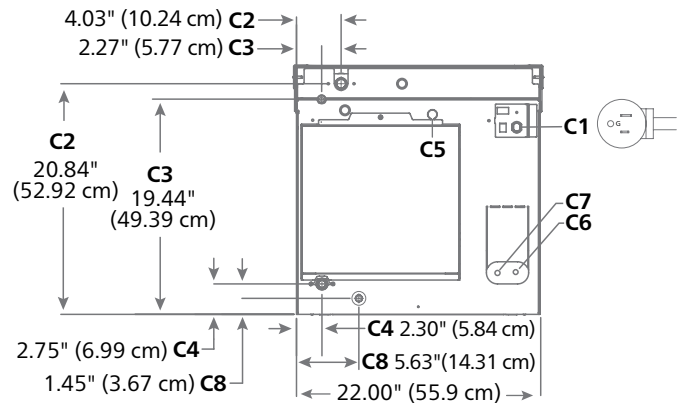
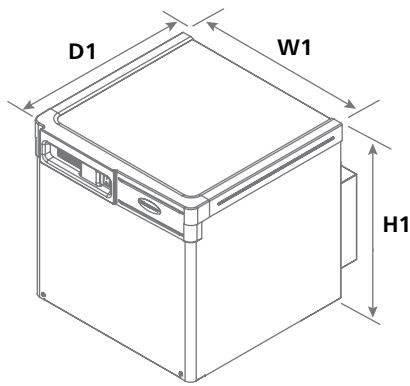

Specification, evaporator unit

W1 Width	22.70" (57.7 cm) Fits on 22.00" wide dispensers
D1 Depth	23.70" (60.2 cm)
H1 Height	22.50" (57.2 cm)
Clearance	top, left and right – 1.00" (2.54 cm)
C1 Electrical	5 amps, requires dedicated 15 amp circuit, 6' (1.8 m) cord, NEMA 5-15 plug 115 V/60/1
Operating power	368 W
C2 Ice transport tube	see page 7 for details
C3 Water inlet	3/8" OD push-in water inlet – internal connection
C4 Drain	3/4" MPT, 1" drain required. See page 7 for details.
C5 Ice bin signal cord	for Vision applications only
C6 Liquid line	3/8"
C7 Suction line	7/8"
C8 Auxiliary drain (required)	3/8" OD push-in
Air temperature	50 - 100 F (10 - 38 C)
Water temperature	45 - 90 F (7 - 32 C)
Potable water pressure	10 - 70 psi (69 - 483 kPa)
Ice production	see ice production chart on page 8
Energy consumption	1810 series: single phase – 4.59 kWh, three phase – 3.33 kWh 90 F (32 C) air, 2110 series: single phase – 4.65 kWh, three phase – 2.93 kWh 70 F (21 C) water per 100 lb (45.4 kg) ice
Water consumption	12.4 gal (47 L) of potable water per 100 lb (45.4 kg) of ice (per AHRI test standards). 13.9 gal (53 L) at low TDS flush setting.
Refrigerant	R404a
BTU/hr (Kcal/hr) at 0 F (-18 C) evaporator, 90 F (32 C) ambient air	1810 series: 15,700 (3,956) 2110 series: 18,200 (4,586)
Rack systems EPR valve set point	0 F (-18 C)
EPR valve to be supplied by installer	
Approximate ship weight	1810 series: 195 lb (79 kg) 2110 series: 205 lb (93 kg)
Approximate net weight	1810 series: 136 lb (62 kg) 2110 series: 167 lb (76 kg)

NOTE: For indoor use only. Outdoor installation of evaporator unit is not recommended and will void warranty.

SHORT FORM SPECIFICATION: Follett® Horizon Elite ice machine model _____ capable of producing compressed nugget ice using an efficient, sanitary horizontal evaporator/auger system and delivering ice by a flexible wire reinforced transport tube to _____ ice storage bin, _____ ice and water dispenser, _____ countertop ice and beverage dispenser, _____ Vision dispenser, _____ drop-in dispenser or _____ Ice Manager diverter valve system. Slide-out evaporator with utility docking station, front-mounted unit status display, evaporator water inlet at harvest end with automatic flush while producing ice, and semi-automatic cleaning and sanitizing system.

Dimensional drawing

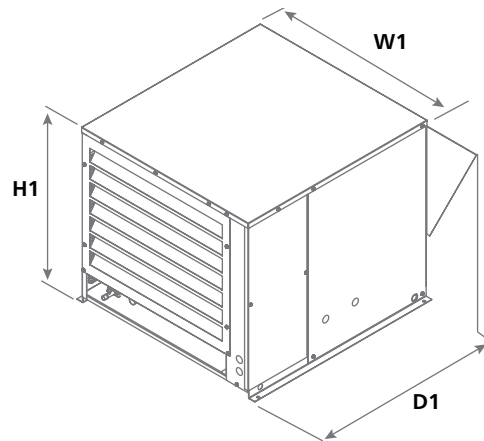

Specification, condenser unit

W1 Width	30.00" (76.2 cm)
D1 Depth (hail guard included)	38.50" (97.8 cm)
H1 Height	25.75" (65.4 cm)
Electrical	1810 series: single phase – 208-230/60/1, three phase – 208-230/60/3 2110 series: single phase – 208-230/60/1, three phase – 208-230/60/3
Operating power	1810 series: single phase – 6.0 kW, three phase – 3.6 kW 2110 series: single phase – 6.2 kW, three phase – 4.6 kW
Minimum circuit ampacity	1810 series: single phase – 26.2 A, three phase – 15.7 A 2110 series: single phase – 27.1 A, three phase – 19.9 A
Maximum circuit HVACR breaker size	1810 series: single phase – 45 A, three phase – 25 A 2110 series: single phase – 45 A, three phase – 30 A
Outdoor condensing unit operating limits (air temperature)	min -20 F (-29 C) max 120 F (49 C)
Maximum refrigerant line run length	75' (22.9 m)
Maximum line rise above evaporator	35' (10.7 m)
Evaporator mounting above condenser	15' (4.6 m)
Maximum refrigeration line drop without oil trap	15' (4.6 m)
Refrigerant charge	14.5 lb pre-charged at factory
Approximate ship weight	1810 series: 265 lb (120 kg) 2110 series: 315 lb (143 kg)
Approximate net weight	1810 series: 212 lb (96 kg) 2110 series: 262 lb (119 kg)

1 – Locating the ice machine

Horizon Elite remote Chewblet ice machines allow top-mounting or mounting in a base cabinet, on a wall or on a floor stand up to 75' (22.9 m) from the dispenser or ice bin with RIDE technology. In-cabinet mounting (RIDE applications) require special attention to service access, unit ventilation and ice transport tube runs (see pages 6-7).

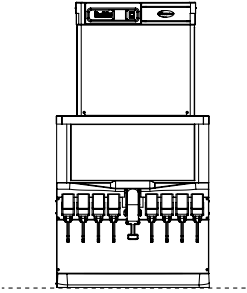
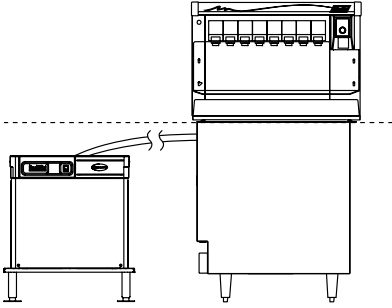
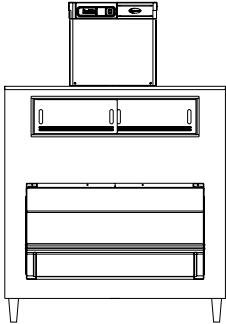
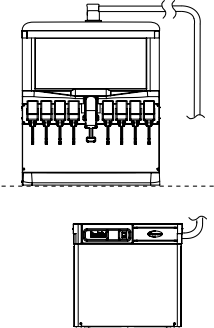
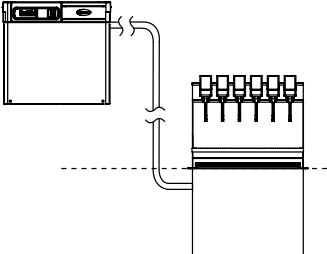
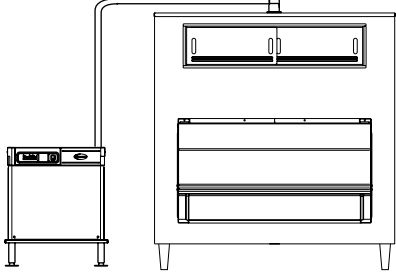
<p>Top mounting – ice and beverage dispensers (by others)</p>	<p>RIDE model – Follett low-profile Vision ice and beverage dispensers</p>	<p>Top mount on Follett ice storage bins</p>
		
<p>Important specifier notes</p> <ol style="list-style-type: none"> 1. Dispenser must be compatible with nugget ice. See page 5 for compatible ice and beverage dispenser models and top kit numbers. 2. Verify ceiling or soffit height to ensure sufficient top clearance. 	<p>Important specifier notes</p> <ol style="list-style-type: none"> 1. See page 6 for critical clearance requirements. 2. Ice transport tube ships with Vision ice and beverage dispenser (Vision applications only). 	<p>Important specifier notes</p> <ol style="list-style-type: none"> 1. See form# 8590 for bin sizing. Not for use with Ice•DevIce™ or Ice Pro™. 2. Verify ceiling or soffit height to ensure top clearance. 3. Locate floor sink or grate and drains in front of storage bin.
<p>RIDE model – ice and beverage dispensers (by others)</p>	<p>RIDE model – drop-in beverage dispensers (by others)</p>	<p>RIDE model – Follett ice storage bins</p>
		
<p>Important specifier notes</p> <ol style="list-style-type: none"> 1. Dispenser must be compatible with nugget ice. Compatible dispensers include Cornelius DB/ED/DF150/175, Lancer 4500-22N, FS-16N and FS-44N, Servend MD150/175/200/250 SV150/175/200/250 and Follett Symphony Plus™ 110CM, as well as dispensers listed on page 5. 2. Coca-Cola Freestyle 7100 requires top adapter IC Code 46751 and ice kit IC Code 46430 only, and must be ordered from Coca-Cola. Coca-Cola Freestyle 9100 requires top kit HSF26SC. Consult with Coca-Cola and Follett to qualify application prior to ordering. 3. RIDE application is approved only for Pepsi Spire 3.0, 5.0 and 4.1 designed for top mount ice machines and requires MSP24SC for 3.0 and MSP30SC for 5.0 and 4.1, ordered separately. For manual fill versions of Pepsi Spire 3.0, 5.0 and 4.1, contact factory. 4. See page 6 for critical clearance requirements. 	<p>Important specifier notes</p> <ol style="list-style-type: none"> 1. Compatible with the following dispensers: Cornelius 1522, 1722, 2323 and Lancer 2200, 2300, 23300. 2. Requires 12.00" (30.5 cm) of access space for installation on transport tube side. 3. See page 6 for critical clearance requirements. 	<p>Important specifier notes</p> <ol style="list-style-type: none"> 1. See form# 8590 for bin sizing. Not for use with Ice•DevIce or Ice Pro. 2. Locate floor sink or grate and drains in front of storage bin.

1 – Locating the ice machine (continued)

Top mounting – compatible ice and beverage dispensers ¹					
Manufacturer	Model Number	Width in (cm)	Depth ² in (cm)	Height ³ in (cm)	Top kit
Coca-Cola dispensers	Freestyle 7000	30.10 (76.5)	33.11 (79.0)	47.00 (119.4)	H22F30-F ⁴
	Freestyle 7100	30.00 (76.2)	33.80 (85.8)	47.00 (119.4)	H22F30-F ^{4,5}
	Freestyle 9000	25.50 (64.8)	35.50 (90.2)	73.75 (187.3)	H22F24-F ^{4,6}
	Freestyle 9100	25.50 (64.8)	39.25 (99.7)	77.2 (196.2)	H22F26-F ⁴
Cornelius dispensers	DB/ED/DF 200 series	30.00 (76.2)	30.00 (76.2)	34.38 (87.3)	H22C30-F or H22C30-X ⁷
	DB/ED/DF 250 series	30.00 (76.2)	30.00 (76.2)	38.38 (97.5)	H22C30-F or H22C30-X ⁷
	DB/ED/DF 300 series	44.00 (111.8)	30.00 (76.2)	34.00 (86.4)	H22C44-(F or B) ⁸
	FlavorFusion/Overload	30.00 (76.2)	30.70 (78.0)	39.38 (100.0)	H22C30-F-FF
	IDC215	30.00 (76.2)	30.70 (78.0)	39.38 (100.0)	H22C30-F-IDC
	IDC255 and Pro Fast Gate	30.00 (76.2)	30.70 (78.0)	36.38 (92.4)	H22C30-F-IDC
	IDC Pro	30.00 (76.2)	33.13 (84.2)	40.25 (102.2)	H22C30-X-PRO ⁹
Lancer dispensers	4500-30N	30.00 (76.2)	30.50 (77.5)	36.50 (92.7)	H22L30-(F or B) ⁸
	FS-22N	22.00 (55.9)	30.50 (77.5)	42.13 (107.0)	H22L22-F
	FS-30N	30.00 (76.2)	30.50 (77.5)	42.13 (107.0)	H22L30-(F or B) ⁸
	Bevariety	30.00 (76.2)	31.00 (78.7)	37.75 (95.9)	H22L30-F-STP
	Bold 30i	30.00 (76.2)	34.25 (87.0)	43.75 (111.12)	H22L30-F-STP
	Sensation 30"	30.00 (76.2)	31.00 (78.7)	38.25 (97.2)	H22L30-F-STP
	Sensation 44" / Twin Pour	44.00 (111.8)	31.00 (78.7)	39.38 (100.0)	H22L44-F-STP
Pepsi dispensers	Touchpoint	32.50 (82.55)	33.70 (85.6)	40.00 (101.6)	H22L30-F-STP
	Spire 3.0	27.00 (68.6)	35.00 (88.9)	38.12 (96.8)	H22P24-F
Servend dispensers	Spire 5.0 / 4.1	30.50 (77.5)	36.00 (91.4)	42.75 (108.6)	H22P30-F
	SV200	30.00 (76.2)	33.13 (84.2)	37.63 (95.6)	H22S30-F
	MDH-302	42.75 (108.6)	31.00 (78.7)	32.38 (82.2)	H22S44-(F or B) ⁸
	MDH-402	60.00 (152.4)	30.50 (77.5)	32.38 (82.2)	H22S60-(F or B) ^{8,10}

¹ All approved dispensers can be filled with a RIDE model Horizon Elite ice machine without a top kit except for Pepsi Spire 3.0, 5.0 and 4.1, see page 4 for details.

² Requires minimum 0.50" (1.27 cm) clearance between back of dispenser and wall.

³ Net height after installation of top kit (excluding height of ice machine).

⁴ Consult with Coca-Cola and Follett to qualify application prior to ordering.

⁵ Top adapter IC Code 46753 and ice kit IC Code 46430 must also be ordered from Coca-Cola.

⁶ Adapter must also be ordered from Coca-Cola. KO IC Code: 46010 (Silver), 46011 (Red) or 46012 (Black).

⁷ Top designed with flexibility to accommodate front or back mounting.

⁸ Specify "F" for front facing, or "B" for backward facing units.

⁹ Top designed with flexibility to accommodate front or back mounting.

¹⁰ 60-inch models: Please specify number of Horizon Elite ice machines and location. D = 2; R = 1 on right side; L = 1 on left side.

2 – Undercounter/in-cabinet mounting

Cabinet details	
<p>Important specifier notes</p> <ol style="list-style-type: none"> 1. Cabinet door opening must meet minimum size requirements shown and be free of obstructions to allow ice machine to slide out (no lip or utilities to block removal). 2. Cabinet base must be capable of supporting ice machine and allow ice machine to rest flat on cabinet bottom. 3. No counter supports, electric or plumbing can run in front of the ice machine. 	<p>Ice transport tube minimum 1/4" per foot (2 cm per meter) pitch toward ice machine secure to prevent dips and traps from forming</p> <p>Cabinet door opening 24.00"W x 23.5"H (60.9 cm x 59.7 cm) minimum</p> <p>Cabinet base must be flat and free of obstructions (no lip or utilities to block removal)</p> <p>12.00" (30.5 cm) minimum between ice machine and dispenser</p> <p>slides out</p>

3 – Horizon Elite ice machine mounting accessories

Optional wall mount bracket	Optional machine stand	Important specifier notes
<p>23.00" (58.4 cm)</p> <p>25.50" (64.8 cm)</p> <p>22.00" (55.9 cm)</p>	<p>6.88" (17.5 cm)</p> <p>A - 15.875" (40.3 cm) C - 13.00" (33.0 cm) B - 19.375" (49.2 cm) D - 21.00" (53.3 cm)</p>	<ol style="list-style-type: none"> 1. For secure wall mounting, specify optional wall mount bracket. 2. Wall and fasteners must support the weight of the ice machine, bracket, supply water and ice. Use of a backing board may be required with hollow wall construction. 3. Machine stand mounting adds 6.88" (17.5 cm) to height of ice machine. 4. No dips in tube routing allowed. 5. Ice transport tube needs minimum 1/4" per foot (2 cm per meter) pitch toward ice machine and should be secured to prevent dips and traps from forming.

4 – Horizon Elite drains - specifier guidelines

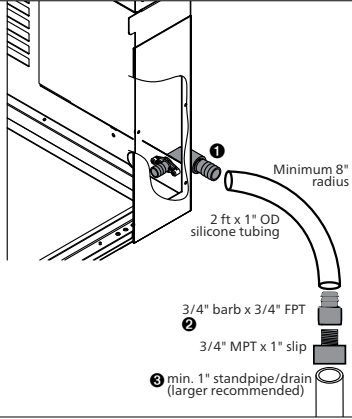
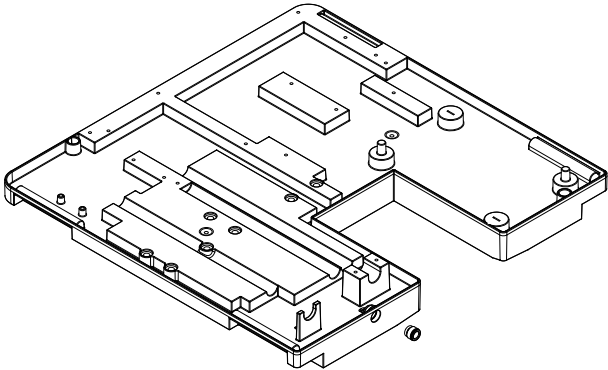
<p>Ice machine drain plumbing</p>  <p>Minimum 8" radius</p> <p>2 ft x 1" OD silicone tubing</p> <p>3/4" barb x 3/4" FPT</p> <p>3/4" MPT x 1" slip</p> <p>min. 1" standpipe/drain (larger recommended)</p>	<p>Important specifier notes: Where code allows, follow recommendation below.</p> <ol style="list-style-type: none"> 1. Apply Teflon tape to 3/4" male outlet ice machine fitting. Thread on either the provided straight 3/4" barb adaptor or a 90 degree adaptor. Connect the supplied 2' (0.61 m) silicone hose to the 3/4" drain barb ①. 2. It is recommended that the silicone hose be routed down into a 1.5" or 2" standpipe/drain. The minimum drain size for the ice machine is 1". <p>NOTE: 3/4" to 1" PVC adapter fittings are provided if a larger drain size is not possible ② ③.</p> <p>NOTE: Minimum 8.00" (20.3 cm) radius on silicone drain line. Drain line from the ice machine must have at least 1/4" per foot pitch (6.4 mm/0.3 m).</p> <p>NOTE: Standpipe/drain provided by others. All other components provided with ice machine.</p>
<p>Chassis drain plumbing – Required</p> 	<p>Important specifier notes: Where code allows, follow recommendation below.</p> <ol style="list-style-type: none"> 1. Route 3/8" drain tubing through knockout in back of docking station and insert fully into John Guest fitting connection at the rear of the machine chassis. Route other end of 3/8" drain tubing to drain. 2. Drain must slope 1/4" inch per foot (6 mm per 30.4 cm).

5 – Horizon Elite ice tube runs - specifier guidelines

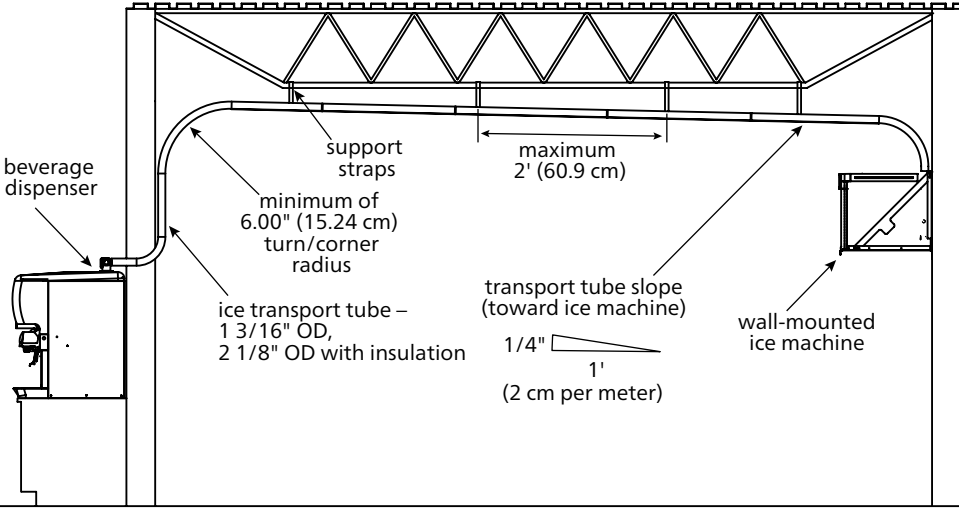
<p>Long tube runs for RIDE remote ice delivery equipment</p>  <p>beverage dispenser</p> <p>support straps</p> <p>minimum of 6.00" (15.24 cm) turn/corner radius</p> <p>ice transport tube – 1 3/16" OD, 2 1/8" OD with insulation</p> <p>maximum 2' (60.9 cm)</p> <p>transport tube slope (toward ice machine) 1/4" 1' (2 cm per meter)</p> <p>wall-mounted ice machine</p>	<p>Important specifier notes</p> <ol style="list-style-type: none"> 1. 75' (22.9 m) maximum ice transport tube run. 2. Tubing routing bends must have a 6.00" (15.24 cm) radius or larger. 3. Dips and traps are not allowed. A 3.00" (7.62 cm) or larger PVC pipe chase is suggested to support the tubing run. If not supported, secure insulated ice transport tube at least every 2' (0.61 m) to prevent dips and traps. 4. Relative humidity levels above 80% in areas where the ice machine or ice transport tube is located may produce excessive condensation that will cause water damage. 5. Contact factory for recommendations on running tubing through a decorative soffit or chase.
--	--

Remote condensing unit

Condensing unit installation specifications

Important specifier notes

1. Provide front, back, top and side clearances as shown.
2. The maximum refrigerant line run length is 75' (22.9 m).
3. 14.5 lb of refrigerant is pre-charged at the factory.
4. The maximum line rise above the evaporator is 35' (10.7 m). Condensing unit above evaporator unit – 35' (10.7 m) (installations with rise over 20' (6.1 m) require additional suction line s-trap at midpoint rise) and p-trap at top of riser.
5. The evaporator can only be mounted a maximum of 15' (4.6 m) above the condensing unit.
6. P-trap required at bottom of suction riser.

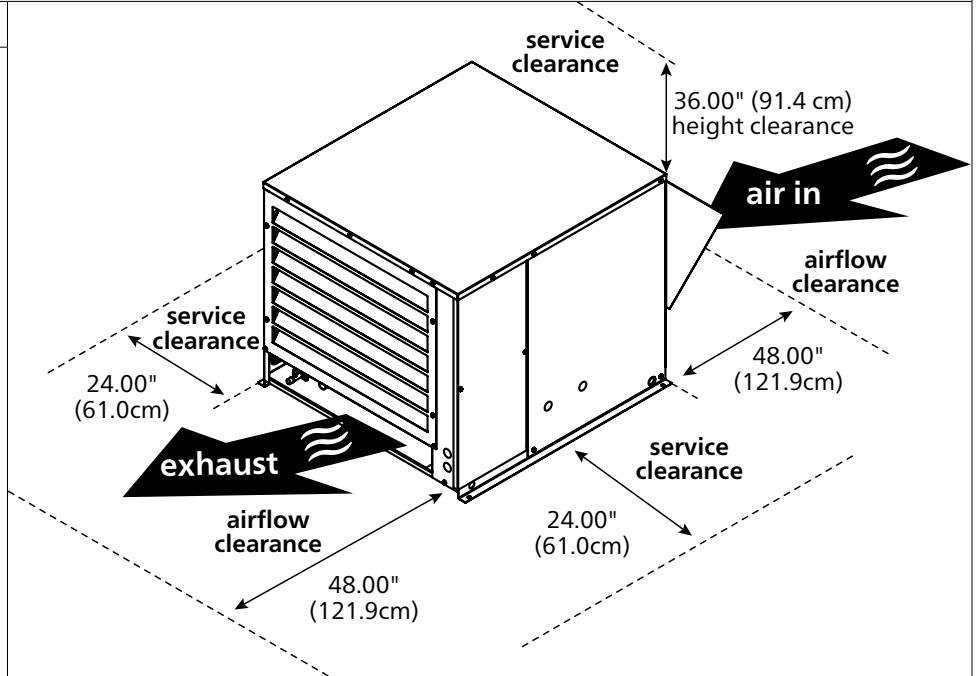

Ice production – Horizon Elite D1810R series

Inlet water temperature F (C)	Ambient air temperature F (C)					lb (kg) production in 24 hr
	60 (16)	70 (21)	80 (27)	90 (32)	100 (38)	
50 F (10 C)	1859 (844)	1784 (810)	1685 (765)	1616 (734)	1500 (681)	
60 F (16 C)	1723 (782)	1684 (765)	1578 (716)	1563 (710)	1409 (640)	
70 F (21 C)	1620 (735)	1594 (724)	1514 (687)	1420 (645)	1319 (599)	
80 F (27 C)	1550 (704)	1487 (675)	1485 (674)	1351 (613)	1299 (590)	
90 F (32 C)	1471 (668)	1435 (651)	1370 (622)	1285 (583)	1207 (548)	

Ice production – Horizon Elite D2110R series

Inlet water temperature F (C)	Ambient air temperature F (C)					lb (kg) production in 24 hr
	60 (16)	70 (21)	80 (27)	90 (32)	100 (38)	
50 F (10 C)	2039 (925)	2039 (925)	1934 (877)	1825 (828)	1703 (772)	
60 F (16 C)	1943 (881)	1888 (856)	1878 (852)	1710 (776)	1584 (718)	
70 F (21 C)	1833 (831)	1781 (808)	1789 (811)	1634 (741)	1489 (675)	
80 F (27 C)	1754 (796)	1686 (765)	1643 (745)	1535 (696)	1426 (647)	
90 F (32 C)	1650 (748)	1603 (727)	1577 (715)	1457 (661)	1395 (633)	

ENERGY STAR and the ENERGY STAR mark are registered trademarks owned by the U.S. Environmental Protection Agency.
 Agion is a registered trademark of Sciescent LLC.
 Open Kitchen is a trademark of Powerhouse Dynamics.
 HORIZON ELITE, ICE•DEVICE, ICE MANAGER, ICE PRO, SAFECLEAN PLUS, SANISPONGE, SYMPHONY PLUS and VISION are trademarks of Follett Products, LLC.
 CHEWBLET, FOLLETT and RIDE are registered trademarks of Follett Products, LLC, registered in the US.
 Follett reserves the right to change specifications at any time without obligation. Certifications may vary depending on country of origin.

Remote 1810, 2110 series ice machine