

Installation Guide

Please visit <https://www.follettice.com/technicaldocuments>
for the Operation and Service manual for your unit

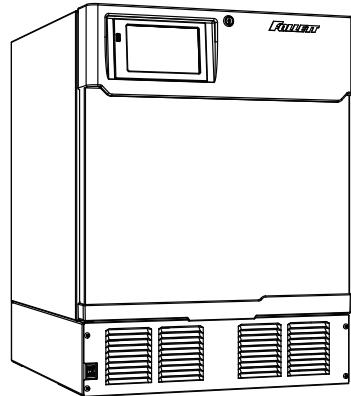

REF5BBi-TR-00-00

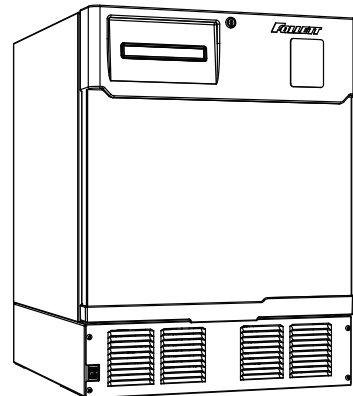

REF5i-0R-KP-00

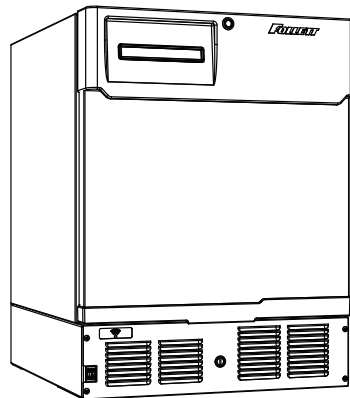

REF5i-0R-MC-00

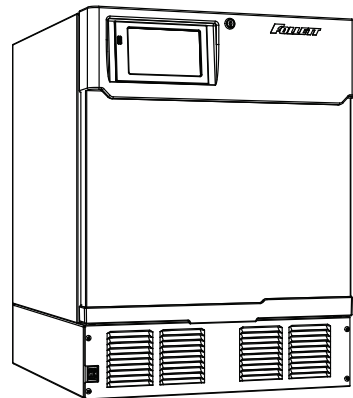

REF5i-TR-KP-00

Welcome to Follett

Follett equipment enjoys a well-deserved reputation for excellent performance, long-term reliability and outstanding after-the-sale support. To ensure that this equipment delivers that same degree of service, review this guide carefully before you begin your installation.

Should you need technical help, please call our Technical Service group at (877) 612-5086 or (610) 252-7301.

Please have your model number, serial number and complete and detailed explanation of the problem when contacting Technical Service.

Getting Started

After uncrating and removing all packing material, inspect the equipment for concealed shipping damage. All freight is to be inspected upon delivery. If visible signs of damage exist, please refuse delivery or sign your delivery receipt "damaged." Follett Customer Service must be notified within 48 hours. Wherever possible, please include detailed photos of the damage with the original packaging so that we may start the freight claim process.

Preliminary Information

Caution Symbols



Warning: Flammable Refrigerant



Caution: Risk of danger to operator or harm to equipment. Refer to manual.

DANGER

- Risk of fire or explosion. Flammable refrigerant used.

Before attempting to install or service this product, all safety precautions must be followed.

CAUTION! – Risk of fire or explosion. Dispose of properly in accordance with federal or local regulations. Flammable refrigerant used.

CAUTION! – Risk of fire or explosion due to puncture of refrigerant tubing; follow handling instructions carefully. Flammable refrigerant used.

CAUTION! – Handling, moving, and operating the refrigerator to avoid either damaging the refrigerant tubing or increasing the risk of a leak.

CAUTION!

- If the equipment is not transported vertically, a period of at least 24 hours must be allowed before starting.

The equipment must be transported and handled exclusively in upright position. This is required to avoid contamination of the refrigerant with compressor oil. Contamination could result in valve and heat exchanger coil failure, problems starting the electric motor, or the risk of gas leak. The manufacturer is not responsible for any problems due to transport executed in conditions other than those specified.

The equipment must be handled using a fork lift truck or a pallet truck with suitable forks (fork length at least equal to 2/3 length of unit).

WARNING!

- Read this manual thoroughly before operating, installing or performing maintenance on the equipment. Failure to follow instructions in this manual can cause property damage, injury or death.
- The machine contains R600a refrigerant. R600a (isobutane) is flammable.
- When servicing the equipment, be sure to lock the circuit breaker, and display an in-service notice.
- This equipment contains high-voltage electricity and refrigerant charge. Installation and repairs are to be performed by properly trained technicians aware of the dangers of dealing with high voltage electricity and refrigerant under pressure. The technician must also be certified in proper refrigerant handling and servicing procedures. All lockout and tag out procedures must be followed when working on this equipment.
- Repair on R600a systems must always be done in a well-ventilated area.
- Because R600a is highly flammable, a combustible gas leak detector is required when servicing R600a systems.
- Keep ventilation openings, in the appliance enclosure or in the built-in structure, clear of obstruction.
- Do not use mechanical devices or other means to accelerate the defrosting process, other than those recommended by the manufacturer.
- Do not damage the refrigerant circuit.
- Do not store explosive substances such as aerosol cans with a flammable propellant in this appliance.
- Do not use electrical appliances inside the food storage compartments of the appliance, unless they are of the type recommended by the manufacturer.
- Only use parts recommended or provided by the manufacturer.
- Do not tilt unit further than 30° off vertical during uncrating or installation.
- If the supply cord is damaged, it must be replaced by the manufacturer, its service agent or similarly qualified persons in order to avoid a hazard.
- This appliance is designed for commercial use.
- To reduce risk of shock, disconnect power before servicing.

Product Loading Guidelines for Optimal Temperature Performance

Maintaining optimal temperature relies on good air circulation, which can be achieved by ensuring that the fan grill and return vent are visible and by loading your refrigerator with 1" of clearance on the top and each side.

 SAFE ZONE - STORE PRODUCT WITHIN THIS AREA

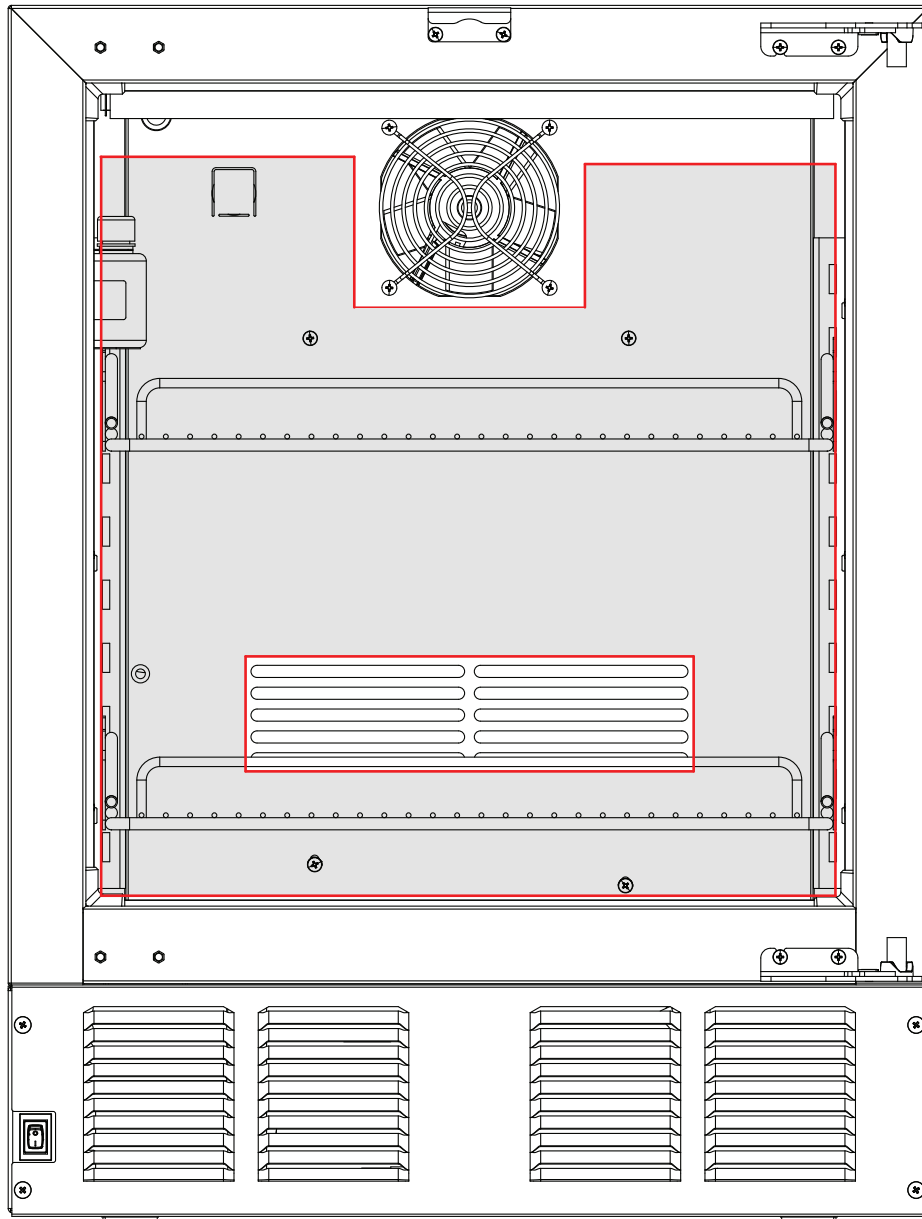

KEEP CLEAR 1" ON EACH SIDE AND TOP.
FAN GRILL AND RETURN VENT MUST BE VISIBLE.

Refrigeration System

The Infinity Series refrigeration system is designed to give many years of trouble-free service. Except for routine cleaning of the air-cooled condenser and related parts, the refrigeration system requires no service or maintenance. The system uses a capillary tube and is critically charged. The connection of refrigeration service hoses to the fittings will almost invariably result in a significant change in the system charge. This change can adversely affect the performance of your refrigerator. Therefore, Follett recommends that if hoses are ever connected to the refrigeration system for service, the refrigerant should be recovered, the system evacuated, and recharged by weighing in the correct refrigerant charge.

Specifications

	REF5i	REF5BBi	REF5i (-MC)
Dimensions (external)	23.75" W x 27.00" D x 31.52" H (60.3 cm x 68.6 cm x 80.1 cm)	23.75" W x 27.00" D x 31.52" H (60.3 cm x 68.6 cm x 80.1 cm)	23.75" W x 27.00" D x 31.52" H (60.3 cm x 68.6 cm x 80.1 cm)
Dimensions (internal)	19.75" W x 18.32" D x 21.54" H (50.2 cm x 46.5 cm x 54.7 cm)	19.75" W x 18.32" D x 21.54" H (50.2 cm x 46.5 cm x 54.7 cm)	19.75" W x 18.32" D x 21.54" H (50.2 cm x 46.5 cm x 54.7 cm)
Storage System	2 wire shelves	2 drawers with total storage of 40 cardboard plasma packs 300 ml/pack)	1-2 MedChill drawers 0-1 wire shelves
Shelf or Drawer Size	18.10" x 19.10" (46.0 cm x 48.5 cm)"	"18.00" x 14.50" x 3.00" (45.7 cm x 36.8 cm x 7.62 cm)"	8-bin: 17" W x 17" D x 3.5" H (43.2 cm x 43.2 cm x 8.9 cm) 3-bin: 17" W x 17" D x 6.5" H (43.2 cm x 43.2 cm x 16.5 cm)
Shelf or Drawer Max Load Rating	55 lbs (25 kg)	55 lbs (25 kg)	MedChill drawer: 17 lbs (8 kg)*
Capacity	4.5 cu ft (127 L)	4.5 cu ft (127 L)	4.5 cu ft (127 L)
Vaccine Storage Usable Space	3.13 cu ft (0.09 m ³)	N/A	1.72 cu ft (0.05 m ³)
Weight (uncrated)	127 lb (57.5kg)	137 lb (62.2kg)	127 lb (57.5kg)

* may include a wire shelf in addition to Medchill drawer(s).

Electrical Specifications

- 115 V, 60 Hz, 1 phase
- Full load: 1.5A
- Minimum circuit ampacity: 15A
- Connect to dedicated circuit, fuse or breaker
- Maximum size of branch circuit overcurrent device: 15A

CAUTION!

- Unit uses a 250V 5A slow-blow 3AG fuse.
- Replace only with same size fuse.

Refrigeration Specifications

Refrigerant	Charge Size (oz)	Maximum Design Pressures (psi)	
		High Side	Low Side
R600a	1.4	125	59

Installation Specifications

Intended for indoor use where:

- Ambient temperature does not exceed 38 C (100 F)
- Ambient relative humidity does not exceed 60% RH
- Altitude is below 2000 m
- Environment is classified as Pollution Degree 2

The front louvered panel must be kept free of any cabinet trim or obstructions to ensure proper ventilation of the refrigeration system.



CAUTION!

- *Equipment must be wired according to local and national electrical codes.*
- *Always disconnect power before servicing refrigerator.*

Installation

Installing Levelers

1. Remove levelers from plastic bag packed inside refrigerator (**Fig. 1**).
2. Tip refrigerator back and screw levelers in all the way to stop (they will extend 1/8" below base of REF).
3. Adjust levelers as needed to level REF in both directions. To access levelers, remove the lower front panel. Turn levelers clockwise to extend levelers.

Fig. 1

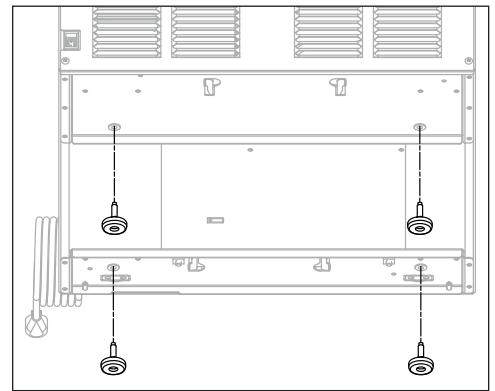

Installing Shelves

1. Remove shelves packed as an accessory (**Fig. 2**).
2. Place top notch of shelf bracket into pilaster, then bottom notch.
3. Press down on top of shelf to lock the shelf into the pilaster.

Fig. 2

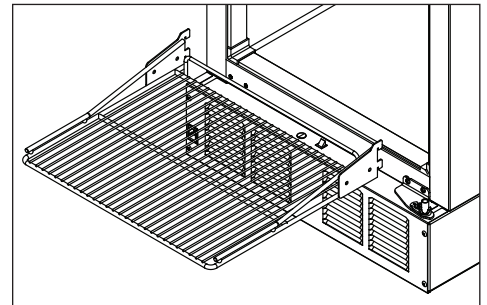

Installing Drawer

CAUTION!

- Do not use casters on units with drawers. Personal injury or damage to unit could result.

1. Remove drawer packed as an accessory (**Fig. 3**).
2. Install the two rollers to the threaded holes on each side of the inside of the cabinet.
3. Hang one drawer slide on the each side of the cabinet by holding the slide parallel to the bottom of the cabinet, tipping the slide at a 45 degree angle, and pushing the slide over the two rollers.
4. Once the drawer slides are installed, slide the two rear rollers of the drawer into the slots on the top of the lower channel of the slides. Tip up the front of the drawer and slide the back until the front drawer roller lines up to slot. Drop the front drawer roller into the channel and push the drawer all the way in the cabinet.
5. Test operation of the drawer by sliding the drawer all the way out, then back in.

Fig. 3

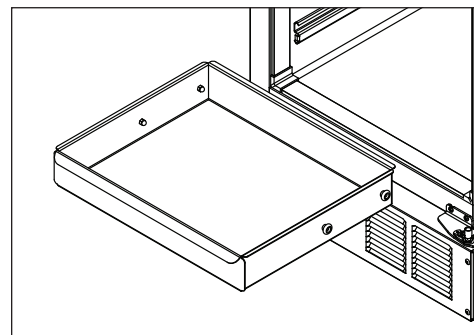

Third-party Probe - Optional

- It is imperative that the probe bottle be filled with a solution that your facility uses to ensure proper operation of unit.
 - Units are equipped with a third-party monitor installation port. Customers are required to refer to CDC Vaccine and Handling Toolkit (cdc.gov) for proper placement of the probe within the cabinet to ensure proper performance.
1. Locate the three sided knockout (**Fig. 4.1**) on the evaporator cover on the inside of the refrigerator, just left of the fan.
 2. Push the knockout with a screw driver until it folds down.
 3. Locate the yellow foam circle on the rear of the box (**Fig. 4.2**).
 4. Using a screw driver, puncture a hole through the foam to make an access hole for the third-party temperature probe.
 5. Fish the temperature probe through the foam circle in the back of the unit, then through the knockout on the evaporator cover.
 6. Position the third party probe in the desired location in the refrigerator cabinet.
 7. Use Permagum* or equivalent sealant to replace foam insulation and ensure proper performance of refrigerator.

* Permagum is a registered trademark of the Presstite Engineering Company.

Fig. 4

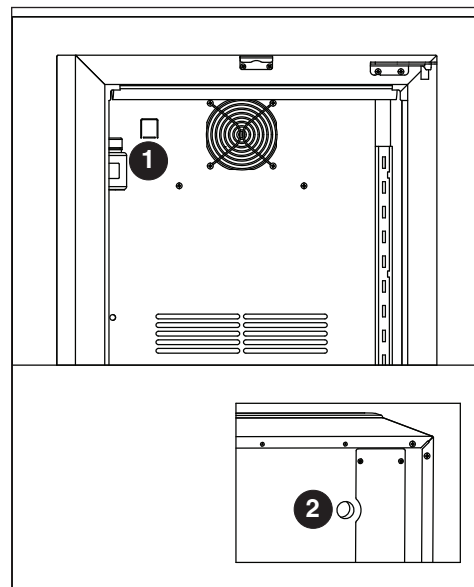

Installing Glycerine Solution in Product Simulation Bottle

(glycerine not included - P/N00959296)

ATTENTION INSTALLER

- It is imperative that the top/bottom probe bottle be filled with a solution that your facility uses to ensure proper operation of unit.
- Units are equipped with a third-party monitor installation port. Customers are required to refer to CDC Vaccine and Handling Toolkit (cdc.gov) for proper placement of the probe within the cabinet to ensure proper performance.
- NSF 456 requires the temperature display probe to be replaced or recalibrated. Follett recommends replacement/recalibration 12 months from the original date of calibration on the Certificate of Traceability supplied with your equipment at the time of purchase. Recalibration or purchasing a new calibrated probe is not covered by the original equipment warranty. To purchase a new Probe with Certificate of Traceability, please contact our Parts Department @ 1-877-612-5086 or partsales@follettice.com

1. Remove the bottle from the bracket located in the upper left side of the refrigerator (**Fig. 5**).
2. Remove the top and fill the bottle with a 50/50 solution of glycerine and water.
3. Replace the top (and probe).
4. Reinsert bottle into the bracket.

Turn on Power

1. Move power switch, located on the bottom left of unit, to the ON position.

Fig. 5

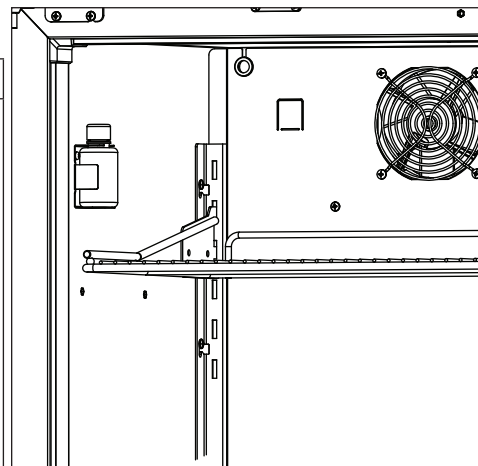
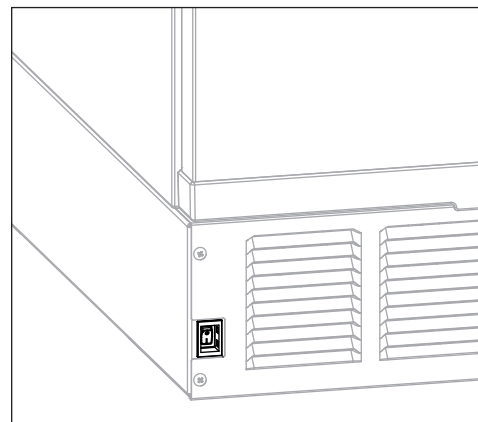

Fig. 6



Operation

The refrigeration system works by removing heat from the cabinet interior and rejecting it to the surrounding room air.

Follett's patented P.I.D. controller allows the refrigeration system to modulate the RPMs of the compressor and condenser fan to match cabinet cooling requirements. The evaporator fan runs at a constant RPM value during cooling system operation.

Proportional Control - Primary

As the return air (P1 probe) temperature rises above the set point value, the compressor and condenser fan RPMs increase to provide additional cooling capacity.

As the return air (P1 probe) temperature approaches the set point, the compressor and condenser fan RPMs are reduced.

As the return air (P1 probe) temperature falls below the set point, the compressor and condenser fan RPMs will run at a minimum level to sustain product and cabinet temperature.

If the return air (P1 probe) temperature falls too far below the set point, the refrigeration system will shut off temporarily until cabinet temperature has increased to an acceptable level, at which point the compressor and fans will power back on.

Integral Control - Secondary

As a secondary control function, the Integral Control analyzes the amount of time that the return air (P1 probe) temperature has been above or below set point value and adjusts compressor and condenser RPMs accordingly.

Derivative Control - Tertiary

As a tertiary control function, the Derivative Control monitors return air (P1 probe) temperature for sudden spikes or drops. When identified, RPMs are adjusted to compensate.



Defrosting

Infinity Series undercounter refrigerators do not require manual defrosting. The unit defrosts automatically during an off-cycle defrost every 8 hours. The defrost terminates when the evaporator coil (P2 probe) temperature reaches 5 C (41 F) or after 30 minutes.

Melted frost from the evaporator coil drains out of the unit into the condensate tray which is located next to the condensing unit. The heat from the condensing unit evaporates any water collected in this tray.

Rechargeable Battery - Touchscreen and Keypad Units Only

Your refrigerator is equipped with a rechargeable SLA AGM 12 V 1.2Ah battery. The unit also includes a charger which maintains battery charge in readiness of a potential power failure event.

 CAUTION	
	<ul style="list-style-type: none">▪ Risk of hazard if non-rechargeable or otherwise improper battery is installed in the system.▪ If battery maintenance is required, use only appropriate Follett-authorized service part or compatible SLA AGM 12 V 1.2Ah battery.

Controller Operation - Infinity Series

In normal operation, the controller displays product temperature in degrees C (default) or user-selected degrees F. The controller is pre-programmed with a 4.4 C (40 F) set point. **COMP** displays when the compressor is running. If this set point does not meet your specific application needs, instructions for changing the set point are found below.

Controller Display

The controller display will show the product/bottle temperature in degrees C or degrees F as selected by the user except when the unit is in an alarm.

The controller has system indicators above the temperature display to let you know when: the compressor is energized (**COMP**), the evaporator fan is energized (**FAN**) or the unit is in defrost (**DEF**).

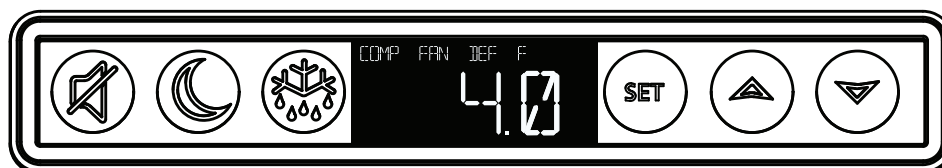

To display temperature Set-point		
Step	Input	Display
1	Press and release SET	Current set-point temperature will display for approximately 5 seconds. Display will return to current product temperature.

To change temperature Set-point		
Step	Input	Display
1	Press and hold SET for 3 seconds	Set-point will flash.
2	Press UP or DOWN arrows to desired set-point	New temperature set-point will flash on the display.
3	Press and release SET to accept	Product temperature will display.

Controller Security

The controller can be locked so that the set-points in the controller cannot be changed.

1. To lock, press **UP** and **DOWN** arrows simultaneously until **LOC** appears (approximately 5 s).
2. To unlock the controller, press up and down arrows simultaneously until **UNL** appears. Changes are only accepted when the controller is unlocked.

Changing Temperature Display from C to F

1. Press **SET** and **UP** arrow simultaneously until **L1** is displayed.
2. Press the **UP** arrow until **UNT** is displayed. Press **SET** then use the **UP** and **DOWN** arrows to change the temperature display from C to F. Press **SET** to accept. The display will return to the temperature in approximately 10 s.

Sleep Function

Press the **SLEEP** button to blank the display, or press any button to wake the display. If the unit goes into an alarm, the display will wake to display the alarm.

Temp Log

High and low log display

1. Press the **UP** arrow to display the highest temperature the refrigerator has recorded since last reset or power cycle.
2. Press the **DOWN** arrow to display the lowest temperature that the refrigerator has recorded since last reset or power cycle.

Reset high and low log

1. Press **UP** or **DOWN** arrow until recorded temperature is displayed.
2. Press and hold **SET** until **RST** is displayed.

Alarming Functions

Set High and Low Alarms

1. Press and hold **SET** and **UP** arrows simultaneously until **L1** is displayed. Use the **UP** and **DOWN** arrows to navigate parameters.
2. The **low** temperature alarm parameter is **AIL**. Once the parameter is displayed, press **SET** to display the low alarm temperature. The alarm temperature will flash on the display. Use the **UP** and **DOWN** arrows to set the alarm temperature. Press **SET** to accept.
3. The **high** temperature alarm parameter is **AIH**. Once the parameter is displayed, press **SET** to display the high alarm temperature. The alarm temperature will flash on the display. Use the **UP** and **DOWN** arrows to set the alarm temperature. Press **SET** to accept.

Note: All models have the alarms factory preset to 2 C (35.6 F) and 8 C (46.4 F).

Start-up Alarm Delay

The Infinity Series unit has a 120 minute time delay between when the unit is energized to when the temperature alarms become active. This delay can be change in parameters in the controller under **Alarm Startup Delay (ASd)**.

Mute the Alarms

The mute button is used to temporarily mute the audible alarm for 10 minutes. If the alarm condition of the unit has not changed in 10 minutes, then the alarm will sound again.

Alarm Acknowledgement and Alarm Reset

The alarm will need to be acknowledged after the alarm condition has been resolved, before the alarm will reset. To acknowledge the alarm press and hold set until the RST is displayed.

Probe Calibration

NSF 456 requires the temperature display probe to be replaced or recalibrated. Follett recommends replacement/recalibration 12 months from the original date of calibration on the Certificate of Traceability supplied with your equipment at the time of purchase. Recalibration or purchasing a new calibrated probe is not covered by the original equipment warranty. To purchase a new Probe with Certificate of Traceability, please contact our Parts Department @ 1-877-612-5086 or partsales@follettice.com

Alarm Codes

When the unit senses an alarm, the display will flash the following codes.

Value	Description
HA1	Temperature is above the High Alarm #1 set point.
LA1	Temperature is below the Low Alarm #1 set point.
DFA	Defrost time out (lasted the full 30 minutes)
Lob	Low battery alarm.
dA	Door open alarm.

Error Codes

Value	Description
P1-P3	Controller is not sensing the probe.
F9	Error saving new parameter values to permanent storage.
F10	Incomplete model configuration.
F11	Number/membrane is sticking.
F21	Key shorted on user interface.
F22	Communication error with user interface.
F23	Communication error with Machine Control.

Advanced Settings

The refrigerator can be further customized through the first level (L1) and second level parameters (L2) in the chart below.

1. Press and hold **SET** and **UP** arrows simultaneously until **L1** is displayed.
2. Use the **UP** and **DOWN** arrows to navigate the parameters. When the desired parameter is displayed, press **SET**.
3. Use the **UP** and **DOWN** arrows to navigate the sub menu of the parameter. Press **SET** to accept and the display will return to the parameter list (after 30 seconds the display will return to the temperature display).

Parameter	Display	Description
Beeper Function	bPr	Controls the audible beeper function on the controller. Off, All, door, Alarm, Error.
Beeper Volume	bPu	Sets the volume of the beeper: 0 (minimum) to 10 (maximum).
Button Clicks	btc	Sets if a beep should sound each time a button is pressed. Yes or No.
Sleep Function	SLP	Determines if sleep function activated from the panel. Yes or No.
Sleep Timer	SLt	Amount of time before the screen blanks automatically. 0 s to 600 s.
Alarm1 High Temp	A1H	High temperature to activate alarm1. User set point to 121 C (250 F).
Alarm1 Low Temp	A1L	Low temperature to activate alarm1. User set point to -46 C (-50 F).
Alarm1 Probe	A1P	Probe for Alarm. P1 (cabinet air), P3 (simulation bottle).
Units	unt	Display temperatures in degrees C or F. F or C.

1. Press and hold **SET** and **UP** arrows simultaneously until **L1** is displayed.
2. Press and hold **SET** and **UP** arrows simultaneously again until **L2** is displayed.
3. Use the **UP** and **DOWN** arrows to navigate the parameters. When the desired parameter is displayed, press **SET**.
4. Use the **UP** and **DOWN** arrows to navigate the sub menu of the parameter. Press **SET** to accept and the display will return to the parameter list (after 30 seconds the display will return to the temperature display).

Parameter	Display	Description
Alarm1 Delay	A1d	Alarm1 delay before sounding. 0 to 60 minutes
Alarm1 Function	A1F	Defines the action taken when Alarm2 is activated. NO (normally open), NC (normally closed), R1 (activate relay), R2 (not used), DIS (disable).
Alarm1 Reset	A2r	Temperature difference to reset alarm1. 0 to 10 degrees.
Alarm Ring back	Arb	Defines the time delay until the alarm will resound. 0 to 120 minutes
Alarm Startup Delay	ASd	Defines the alarm delay during startup. 0 to 180 minutes.
Alarm Silencing	ASL	Determines if the alarms can be silenced or not. Yes, No.
Maintain Alarm	nAL	Determines if the alarm (1-3) should be maintained if the temperatures fall back into range. Yes, No.
Probe 1 Calibration	P1C	Offset value for probe 1 calibration. -9.9 to 9.9 .
Probe 3 Calibration	P3C	Offset value for probe 3 calibration. -9.9 to 9.9 .
Controller Parameter Reset	rSt	Reset to restore factory parameters.

Follett Keypad Lock

Default user passcode for first-time users

User Code 01 is factory set by default to **1 2 3 4 5 6**.

Note: In order to continue using 1 2 3 4 5 6 as a default, user-selectable programming codes must be stored in slots 02 to 40.

User Codes 02 to 40 do not have any codes set up and are available for user-programming.

Each time a button is pressed, a chirp will be heard.

To Change the Master Code

The master code is needed to add or change the individual user codes. By default, the master code is set to **1 2 3 4 5 6**.

The master code is stored in User ID # 99.

1. Press **3 6 5**, the *****, followed by the current Master Code, followed by **ENTER** (5 Chirps will be heard).
2. Press **9 9**, followed by **ENTER**. (3 chirps will be heard).
3. Enter the new master code, followed by **ENTER** (3 chirps will be heard).
4. Re-enter the new master code, followed by **ENTER**. (5 chirps will be heard).
 - Pressing [**CANCEL**] at any point will cancel the routine.

To Enter or Change a User Code

1. Press **3 6 5**, the *, followed by the Master Code, followed by **ENTER**. 5 Chirps will be heard.
2. Enter the user ID (a two digit code from 00 to 40), followed by **ENTER**. 3 chirps will be heard.
3. Enter the new user code (6 numbers), followed by **ENTER**. 3 chirps will be heard.
4. Re-Enter the new User Code, Followed by **ENTER**. 5 chirps will be heard to acknowledge that a new code was entered.

Example: To enter a new user code of 4 4 3 3 5 5 for ID # 15

1. Press **3 6 5 * 1 2 3 4 5 6 [ENTER]** (5 chirps will be heard).
2. Press **1 5 [ENTER]** (3 chirps will be heard).
3. Press **4 4 3 3 5 5 [ENTER]** (3 chirps will be heard).
4. Press **4 4 3 3 5 5 [ENTER]** (5 chirps will be heard).

The new code has been entered for the ID.

To Delete a User Code

1. Press **3 6 5**, the *, followed by the Master Code, followed by **ENTER**. 5 Chirps will be heard.
2. Enter the user ID to clear, followed by **ENTER** (3 chirps will be heard).
3. Press **3 3 5, #** (3 chirps are heard) (335 = DEL).
4. Enter the user ID to clear, followed by **ENTER** (2 chirps will be heard).
5. Press **3 3 5, #** (5 chirps are heard).

The code assigned to that user ID has been deleted. If an error is encountered, the control will beep continuously for 3 seconds. The Master Code stored in user ID 99 cannot be deleted.

Example: To delete the user code in ID 15:

1. Press **3 6 5 # 1 2 3 4 5 6 [ENTER]** (5 chirps will be heard).
2. Press **1 5 [ENTER]** (3 Chirps will be heard).
3. Press **3 3 5, #** (3 Chirps will be heard) (335 = DEL).
4. Press **1 5 [ENTER]** (2 Chirps will be heard).
5. Press **3 3 5, #** (5 Chirps will be heard).

Controller Operation - Infinity Series Touchscreen

Use and care of the LCD Infinity Series Touchscreen

















The LCD touchscreen utilizes capacitive touch technology. This will allow you to engage the functionality by touching the screen with your fingers, even while you are wearing latex or cotton gloves. Functionality will not engage by touching with an inanimate object, such as a pen.

- To preserve optimal touch sensitivity, keep the screen clean by using a clean, dry cotton cloth.
- Do not expose the screen to liquids or excessive dust, heat or humidity.

Control function icons and navigation buttons engage functionality of the user interface. Status indicators alert the user to a change of status.

Home screen

The Home Screen consists of three primary information areas: the temperature display, control function display zone and system status display.



Control Functions	System Status	Functions and Settings
 Settings	 Compressor is running	 USB download available (downloading when blinking)
 Alarming	 Evaporator fan is running	 Refrigeration set points
 Light	 Door is open	 Sleep functions
 Information log	 Defrost cycle is in process	 Centigrade to Fahrenheit
 Help		 Probe set points
		 Alarming functions
		 Alarm mute
		 Reset

- Product temperature is displayed in the upper right corner.
- Primary control function icons are displayed in the lower left corner.
- System status icons will display in lower right corner to indicate a condition has been activated.

High and low temperature display

From the home screen touch the temperature display in the upper right corner. The high/low temperatures will appear below the temperature display. To the left of the high/low temperature a time and date stamp will be displayed.

Reset the high and low temperatures

Touch the temperature display a second time and the reset function  will appear under the high and low temperature. Touch the reset icon and a yellow message box will appear. Press  to confirm reset or  to cancel.

Alarm set point display

From the home screen touch the temperature display three times. The High and low alarm set point will appear under the temperature.

Fig. 7

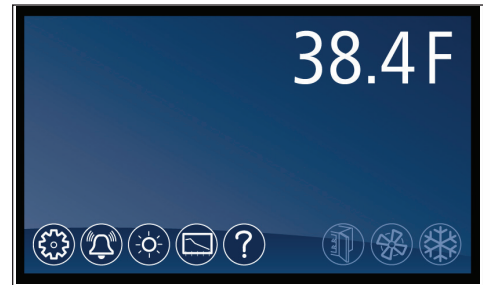

Fig. 8



Fig. 9

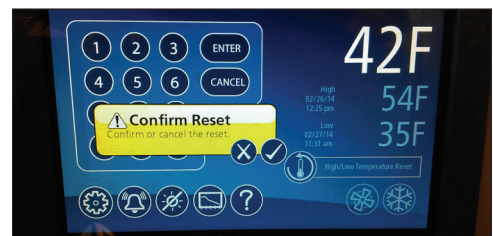

Fig. 10



Help



- Help is available at any time by touching the  icon at the bottom of the screen.
- Help is screen-specific; touching the  icon will display an explanation of the functionality and use of the screen you are currently viewing.
- Touch  to exit help screen.

Fig. 11



Settings



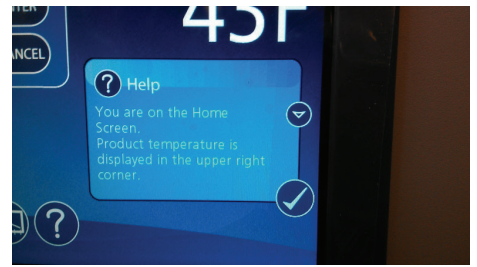





- Refrigeration Set Point 
 - Touch the number displayed in the box to the right of the Set point label and use the keypad or **UP** and **DOWN** arrows to select product temperature between 1 C (36 F) and 10 C (50 F). Press  to accept or  to cancel.
- Sleep Temperature Display 
 - Toggle **ON** to hide the temperature reading immediately on the home screen.
- Set the Sleep Delay 
 - To automatically hide the temperature after 0-600 seconds of inactivity, touch the box to the right of the delay (0-300) box. Use keypad or **UP** and **DOWN** arrows to select from 0-600.
- Temperature
 - Toggle between **F** and **C** to select Fahrenheit or Celsius.
- Brightness 
 - Touch the number displayed in the box to the right of the Brightness  icon and use the keypad or **UP** and **DOWN** arrows to select from 1-10. Press  to accept or  to cancel.

Fig. 12



Fig. 13



System Information



- Touch the System Info icon  to display the model number, unit serial number and software version. Touch the checkbox icon  in the lower right corner of the box to clear.

Fig. 14



Alarm or Alert Notifications





- If an alarm or event condition is detected and an alarm is engaged, an alert notification will appear in the left center of the screen with an explanation of the alert condition and a checkbox  at the bottom right of the alert box.
 - No further action can be taken on the User Interface until the alert condition is acknowledged and cleared by touching the checkbox .
 - Mute 
 - Touch the  icon to mute audible alarm for 15 minutes.
- Note: All models have the alarms factory preset to 2 C (35.6 F) and 8 C (46.4 F).**

Fig. 15



Door Switch

- The Infinity Series touchscreen units have a door switch that is located on the kick plate. The door switch will turn on the LED light and turn off the evaporator fan. If the door is open for more than one minute it will also cycle off the compressor. When the door is closed the evaporator fan and compressor will return to service.

Door Alarm

- The Infinity Series touchscreen units have a door alarm that is factory set for one minute. The alarm will clear when the door is closed. The door alarm activation time can be changed from 0-600 seconds in advanced setting under Door Open Alarm Delay.

Power Alarm

- The Infinity Series touchscreen units have a Power Alarm that will sound if the unit loses power for more than five minutes. The Power loss alarm box will display every five minutes, then the screen will sleep. An audible alarm will sound every 30 seconds during the power failure. An alarm box will be displayed when power is restored. The event log will record the exact time and date of the power loss and when the power was restored.

Start-up alarm delay

The Infinity Series unit has a 120 minute time delay between when the unit is energized to when the temperature alarms become active. This delay can be changed in parameters in the controller under **Alarm Startup Delay**.

Setting Alarms









- Alarming Settings control the conditions and timing of event and alarm conditions that result in audible and/or visual alerts.
- To change the high alarm set point, touch the number displayed in the box to the right of the  icon and use the keypad or **UP** and **DOWN** arrows to select an alarm value. Press  to accept or  to cancel.
- To change the low alarm set point, touch the number displayed in the box to the right of the  icon and use the keypad or **UP** and **DOWN** arrows to select alarm value. Press  to accept or  to cancel.
- Audible Alarm 
 - Toggle between **ON** and **OFF** to engage and disengage the audible alarm function.
- Mute 
 - Touch the  icon to mute audible alarm for 15 minutes.

Fig. 16



Screen saver

The screen saver will replace the home screen and display a blank screen, time and date, or the temperature. When the screen is touched or the unit has an alarm or event, it will return to the home screen. The screen saver can be changed in the advanced setting.

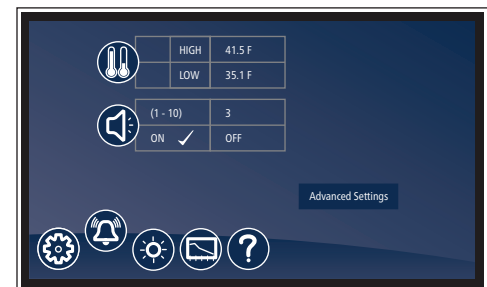
Screen saver function: blank, time and date, or temperature.

Screen saver time (sec): 0—600 seconds between the last touch of the screen to the activation of the screen saver.

Information Logs

- All available graphs, data logs and event logs are accessed through the Information Logs function. The home screen in the Information Logs section displays the product (P3) temperature graph with one week's data. Date and time information is displayed on the horizontal axis.
- The Infinity Series units come factory set to display only the product temperature (**P3**) on the graph. All of the probes on the Infinity Series unit can be viewed on the graph if desired. Probes can be added to the graph through the advanced setting under **P1** to **P3** by selecting the probe and changing the parameter from No to Yes. The selected probe will now display on the graph.
 - P1** control, **P3** Alarm
- Zoom in (+) or Zoom out (–) on an event/temperature on the home screen will change the time scale.
- Using the left and right arrows below the graph will scroll the graph. All the stored temperature data on the graph is viewable.
- Temperature Log – to display a chronological listing of logged temperatures (latest logged temperature will display first), touch the “**Temperature Log**” label to the left of the screen. Use the **UP** and **DOWN** arrows to the right of the screen to scroll through the logged temperatures.
- Event Log – to display a chronological listing of events (including errors, alarms and alerts), touch the **Event Log** label to the left of the screen. Use the **UP** and **DOWN** arrows to the right of the screen to scroll through the logged temperatures.

Fig. 17

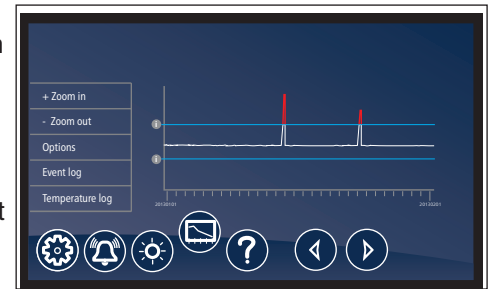

Fig. 18

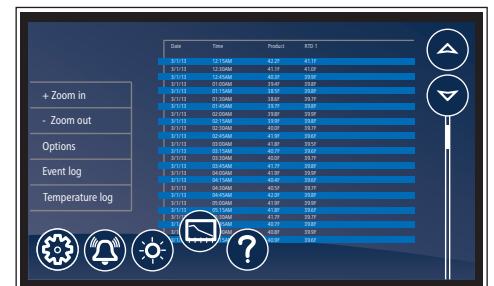

Fig. 19



Keypad access log - download only

Insert USB stick and tap Keypad Log to view. File downloads as an excel compatible .csv file.

Data logging

- The Infinity Series controller is capable of storing up to 50,000 readings per probe. The factory setting for the sample rate is every 15 minutes, which will provide enough storage for 520 days. The sample rate can be change to provide data logging for a longer or shorter time interval by changing the **Sample Rate (Min)** in the advanced settings menu. **0 = off and 360 minutes maximum.**

Data Storage

- Data can be captured different ways. The factory default is for the data to overwrite itself when the memory is full. This can be changed in the advanced setting under **Data storage overwrite**. When this parameter is set to **No**, the system will display an alert when the memory is 75% full. To clear the alert the data must be downloaded.

Data duration alarm

- A reminder can be set to download the data in the **Data duration alarm** in the advanced setting. The data duration can be set from **1 to 180 days**. If the data duration alarm is used, then the **Alarm on data full** parameter in the advanced setting must also be set to **Yes**.

Downloading data

- The touchscreen has the capability of downloading the temperature data and event log via a USB port on the left side of the user interface. The file is a CSV format and is suitable for import directly into Microsoft Excel.

1. Insert the storage device in the USB slot located to the left of the Touchscreen.
2. Select the Graph icon along the bottom of the Touchscreen.
3. Select the USB icon in the lower right hand corner.
4. A yellow alert box with **downloading data** will appear.
5. Press to accept or to cancel.
6. After the unit is done downloading a second yellow alert box will appear asking if you want to **Erase log**.
7. Press to accept or to cancel.

Note: If you chose to erase the data, the data duration timer and the data full alarm will reset. It will also erase the information that is stored on the graph.

One of the two files below will be downloaded depending on which screen is being viewed:

EL XXXX YY - Event Log

TL XXX YY - Temperature Log

XXXX = last 4 digits of serial number

YY = 0-99 number of downloaded file

Data download reminder and data full alarm

- If you plan or are required to download data for a certain time period, you can set a **download data reminder** on the Infinity Series unit. Download data reminder can be found in the advanced setting under **Data duration** and can be set from **1 to 180 days**.

Fig. 20

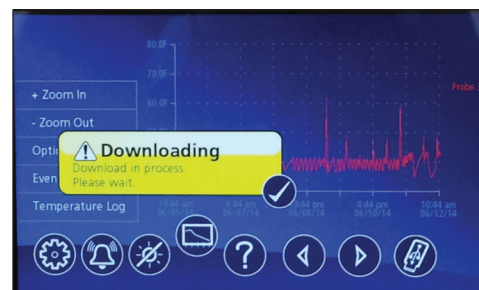
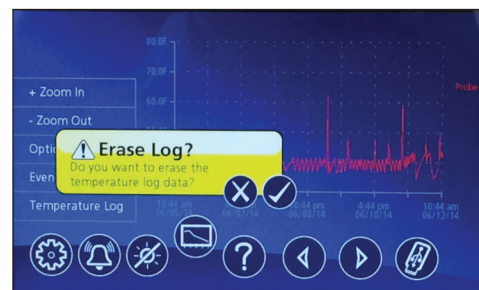

Fig. 21









Follett Keypad Lock

For units enabled with keypad and electronic lock feature, keypad will be displayed on left side of screen.

Default user passcode for first-time users

- Master User Code 01 is factory set by default to **1 2 3 4 5 6**.
- User Codes 01 to 40 are available for user-programming.
- Each time a button is pressed, a chirp will be heard.
- See Page 12 for detailed Follett Keypad Lock instructions.

Changing and Adding the User Codes

1. Touch Settings  icon.
1. Touch **Advanced Settings**, enter your 4-digit user access code (factory default is 1 1 1 1) in the keypad that appears, and touch the checkmark icon  to access advanced settings screens.
2. Time and date will be displayed. Scroll using the **UP** and **DOWN** arrows until **Change Access Code** is displayed in the Display Setup screen.
3. Touch **Change Access Code** and enter the master code [ENTER]. (By default, the master code is 1 2 3 4 5 6.)
4. Touch the screen to the right of the user code 1 to 40 to overwrite or add the user code.
5. Enter the new code. Press  to accept or  to cancel.
6. Enter the new code again. Press  to accept or  to cancel.
7. Press **DONE** when finished entering access codes.

Light

- To turn the interior light on (or off), touch the Light icon or the Light Off icon.
- Light timer is in advanced settings.
- The light will also come on when the door is open

Fig. 22

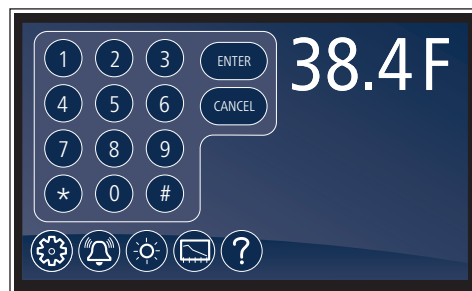

Fig. 23

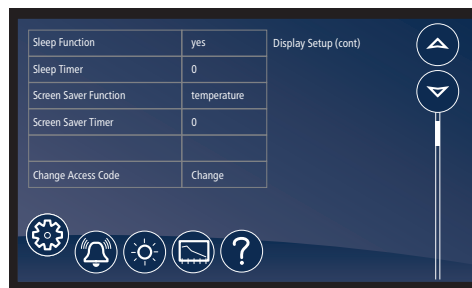
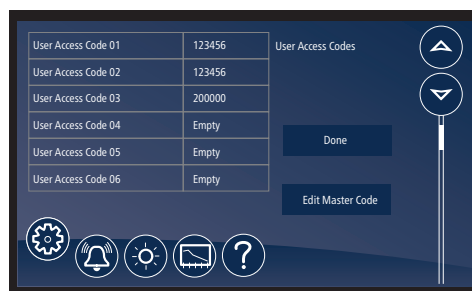











Fig. 24



Time and Date

- To set time and date, press the Settings  icon.
- To display options, touch **Advanced Settings**, enter your 4-digit user access code in the keypad that appears, and touch the checkmark icon  to access advanced settings screens (factory default is 1111).
- Time: touch displayed time and use the keypad to enter the time. Press  to accept or  to cancel.
- AM/PM: touch displayed value to toggle between AM and PM.
- Month: touch number displayed and use the keypad to enter the month. Press  to accept or  to cancel.
- Day: touch number displayed and use the keypad to enter the day. Press  to accept or  to cancel.
- Year: touch number displayed and use the keypad to enter the year. Press  to accept or  to cancel.

Advanced Settings

- Touch **Advanced Settings**, enter your 4-digit user access code in the keypad that appears, and touch the checkmark icon  to access advanced settings screens (factory default is 1111).

Fig. 25



Cleaning

Interior: Using a sponge or soft cloth, clean unit with a non-abrasive, non-chlorinated, all-purpose detergent.

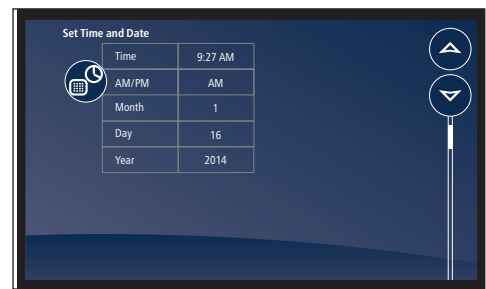
Exterior: Wipe exterior with a soft cloth in the direction of grain as needed. Stainless steel polish may be used to enhance the finish of the unit.

Annual Cleaning

Removal of dust and other particulates from air intake areas and the condenser is important for proper operation. Environments with large amounts of dust may require more frequent cleaning.

Use only non-chlorine-based cleaners. Cleaners containing chlorine can cause staining and pitting of the stainless steel.

1. Disconnect power to unit by turning switch on the lower front panel to the **OFF** position and removing power cord from receptacle.
2. Remove lower front and rear panels (**Fig. 26.1**).

Note: Front louvered panel may be removed for more frequent cleaning of the condenser as needed.

3. Remove drain pan (**Fig. 26.2**). (REF5i drain pan location shown.)
4. Clean drain pan with a non-abrasive, non-chlorinated all-purpose detergent.
5. Reinstall drain pan.
6. Use a vacuum cleaner with brush attachment to clean condenser and related parts through lower rear panel.
7. Reinstall lower rear and lower front panels.

Fig. 26

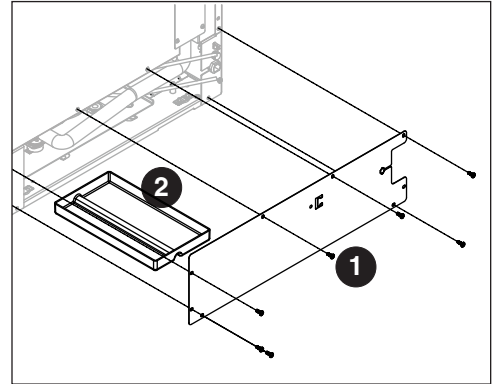

Wiring Diagram

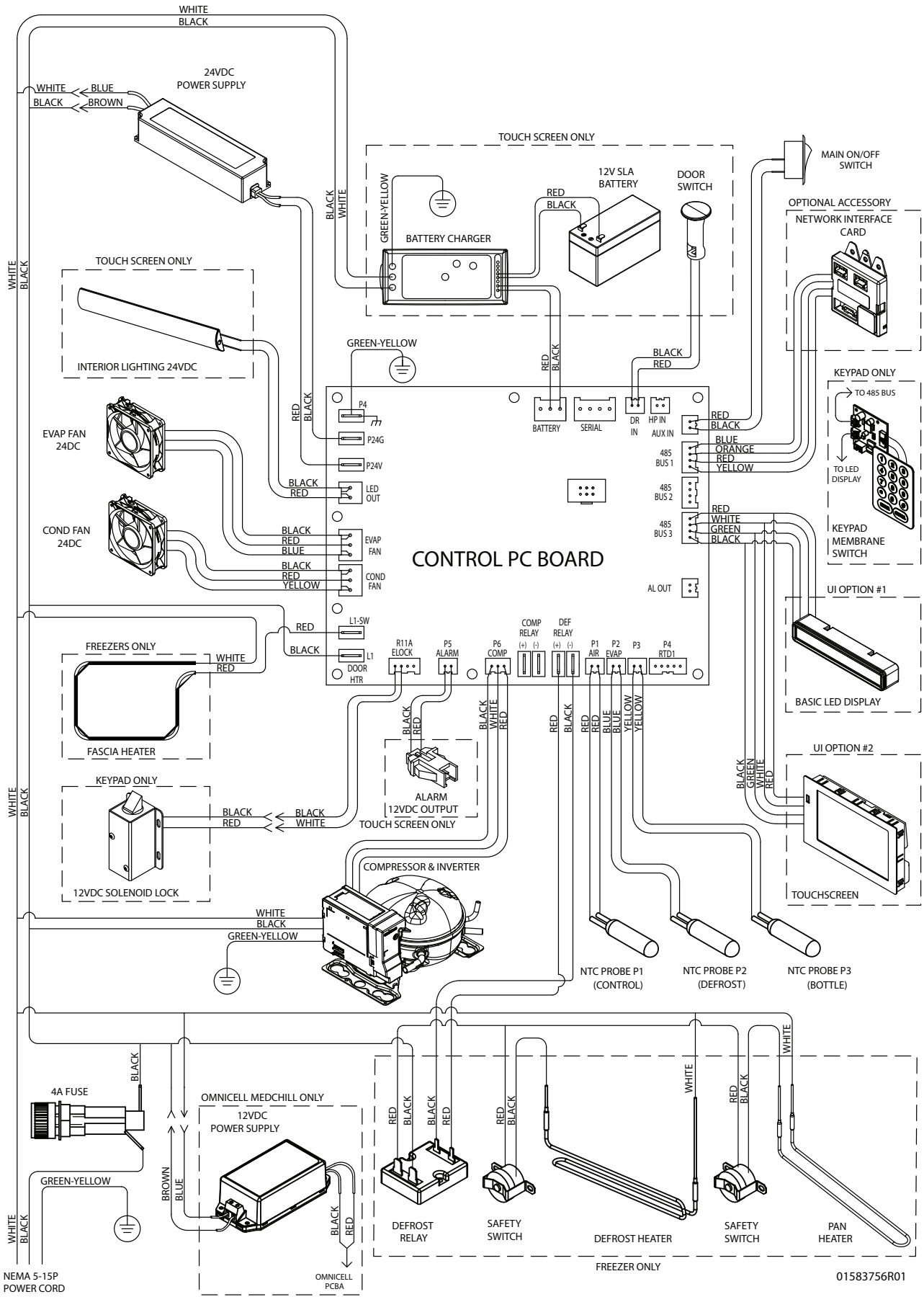

01583756R01

Refrigeration System Diagram

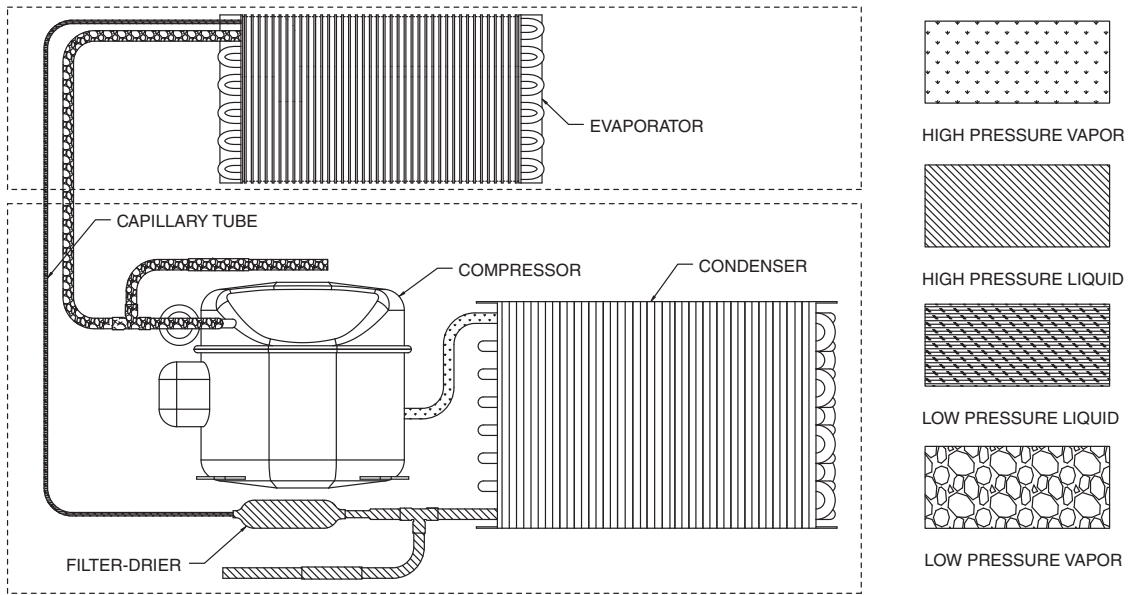

Compressor Information

Compressor model	FMSA4C
Run load amps (RLA)	1.25
Lock rotor amps (LRA)	2.17
Ohms start winding to common	13.2
Ohms run winding to common	13.2
Ohms start winding to run winding	13.2

Troubleshooting

Before calling for service

1. Check that unit is plugged in.
2. Test outlet with another appliance to verify power.

Symptom	Possible Cause	Solution
Refrigerator does not operate (no components run).	Power switch faulty or in OFF position; loose connection.	Turn power switch to ON; check switch and connections.
	Refrigerator not plugged in.	Connect plug.
	No power to cord.	Restore power.
	Temp controller not energizing components.	Check controller contact terminals for power. Replace controller if needed.
	Probe not sensing set point temperature.	Replace controller and/or probe.
Compressor does not run.	Compressor defective.	Replace compressor.
	Touchscreen unit: Check door switch	Replace as required.
Evaporator fan motor does not run.	Defective fan motor.	Replace fan motor.
	Touchscreen unit: Check door switch	Replace as required.
Refrigerator does not shut off.	Controller keeping refrigeration system energized.	Replace controller.
Refrigerator does not maintain temperature (all components run).	Condenser or evaporator coil needs cleaning.	Clean coils.
	Faulty door gasket.	Replace door gasket.
	Excessively high ambient or inadequate air clearance.	Maximum recommended ambient is 100 F (38 F).
	Refrigerant leak.	Locate and repair leak.
	Incorrect refrigerant charge.	Recover, evaluate and weigh in correct charge.
	Plugged capillary tube.	Replace capillary tube and filter drier.
	Inefficient compressor.	Consult technical services.

If problems persist after following this basic troubleshooting guide, call Follett's technical service group at (877) 612-5086.

Warranty Registration and Equipment Evaluation

Thank you for purchasing Follett® equipment. We hope you find that our equipment meets or exceeds your expectations, as our goal is to deliver high value products and services that earn your complete satisfaction!

Please review the enclosed installation and operations manual. It is important that the installation be performed to factory specifications, so your equipment operates to its maximum efficiency.

Follett Products LLC will not be liable for any consequential damages, expenses, connecting or disconnecting charges or any losses resulting from a defect of the machine.

For full warranty details, visit our website www.follettice.com/productwarranties.

Warranty registration and equipment evaluation is important to help us keep track of our equipment and to record the machine's performance. We request that you register Follett equipment warranties on our website www.follettice.com/support and choose Warranty Registration and Equipment Evaluation. It's simple to do; please take a moment to register today. There is also space on the form to provide us with comments and feedback. Please let us know about your experience so we can capture it for our continuous improvement efforts.

We pride ourselves on producing outstanding equipment and we work hard to back it up with outstanding customer and technical support. Please let us know what else we can do to assist you. We would be happy to answer your questions.

Follett HEALTHCARE and Infinity Series are trademarks of Follett Products, LLC.
Follett is a registered trademark of Follett Products, LLC, registered in the US.



801 Church Lane • Easton, PA 18040, USA
Toll free (877) 612-5086 • +1 (610) 252-7301
www.follettice.com/healthcare

01583996R01
© Follett Products LLC 2/26