

# Infinity Series™

## medical-grade undercounter refrigerators



LED controls with optional keypad

Model configurations				
Controls	Hinging <sup>1</sup>	Keypad	Door style	Item number
<b>LED</b>	right	no	stainless	<b>REF5i-OR-00-00</b>
		yes	stainless	<b>REF5i-OR-KP-00</b>
	left	no	stainless	<b>REF5i-OL-00-00</b>
		yes	stainless	<b>REF5i-OL-KP-00</b>

<sup>1</sup> As facing the unit.



7" LCD touchscreen with optional keypad

Model configurations				
Controls	Hinging <sup>1</sup>	Keypad	Door style	Item number
<b>7" LCD touchscreen</b>	right	no	stainless	<b>REF5i-TR-00-00</b>
		yes	stainless	<b>REF5i-TR-KP-00</b>
	left	no	stainless	<b>REF5i-TL-00-00</b>
		yes	stainless	<b>REF5i-TL-KP-00</b>

<sup>1</sup> As facing the unit.

### Features

Patented "infinite speed" control technology delivers superior temperature, noise and energy management

- variable capacity compressor and microprocessor controller provide a  $\pm 1$  C (1.8 F) temperature performance throughout the cabinet
- low GWP natural refrigerant R600a
- extremely quiet
- ENERGY STAR® certified

Protection, convenience and security for your valuable products

- fits below 34.00" (86.4 cm) ADA countertops without casters
- UL certified to meet NSF/ANSI 456 standard for vaccine storage
- refrigeration system settings accessed through door-mounted controls
- exterior LED or 7" LCD capacitive touchscreen (-T models only) digital temperature display available in user-programmable C or F with choice of product or air temperature
- integral event and data logging with easy downloading via USB port (-T models only)
- rechargeable battery (-KP and -T models only)
- user-programmable audible and visual high/low alarms
- quick-connect product temperature probe with 1 year certificate of NIST-traceable calibration
- lighted cabinet (-T models only)
- flush door design is compatible with standard automated dispensing system brackets
- back wall port provides entry for third-party probes
- mechanical lock – mounted on top-center of door
- lockable controller so set points cannot be inadvertently changed
- flexible internal storage configuration (drawers and shelves interchangeable)

Durability and serviceability

- stainless steel construction on exterior and interior
- two epoxy-coated wire shelves standard
- back wall evaporator and front ventilation (no top, back or side clearance required)
- right or left-hinged door with integral handle and magnetic gasket door closure

Warranty

- 2 year parts and labor
- 5 year compressor parts only
- see page 2 for optional extended warranties

Certifications (applied to all products unless otherwise noted)



Vaccine Refrigerator  
NSF 456 – E524732  
Laboratory Equipment  
SAFETY US/CA – E520098



---

## Options and accessories<sup>1</sup>

Additional shelf (1) (item# 01059484)

Drawer accessory kit (1 drawer and glide hardware) (item# 01543933)

Casters (set of 4 with spacers) (item# 01053636)

Pedestal base, 23.75" wide x 25.60" deep x 17.00" high (60.3 x 65.0 x 43.2 cm), stainless (item# 01586122)

Stacking kit (Infinity Series on Infinity Series) (item# 01588953)

Seismic bracket kit (item# 01059104)

Glycerine, 16 oz (item# 00959296)

Replacement overmolded NTC probe with NIST-traceable certificate of calibration (item# 01588961)

Temperature surveillance module (includes alarm, 8.00" (20.32 cm) chart recorder, remote contacts) (item# 01570860)

DicksonOne VFC-compliant freestanding display data logger with Wi-Fi and Ethernet capability for use with any refrigerator or freezer (item# 01528512). NOTE: Subscription from Dickson required to access data on the cloud.

DicksonOne VFC-compliant freestanding touchscreen data logger with Power Over Ethernet and Wi-Fi capability for use with any refrigerator or freezer (item# 01528538). NOTE: Subscription from Dickson required to access data on the cloud.

Ambient temperature and humidity sensor, right angle, for use with DicksonOne freestanding display and touchscreen data loggers (item# 01539691)

Optional extended one year warranty (item# EW12)

- 3 year parts and labor

- 5 year compressor parts only

Optional extended three year warranty (item# EW36)

- 5 year parts and labor

For additional accessories, refer to the form# 8550.

NOTE: Accessories ship separately.

<sup>1</sup> Certifications do not apply to options and accessories.

## Dimensional drawing

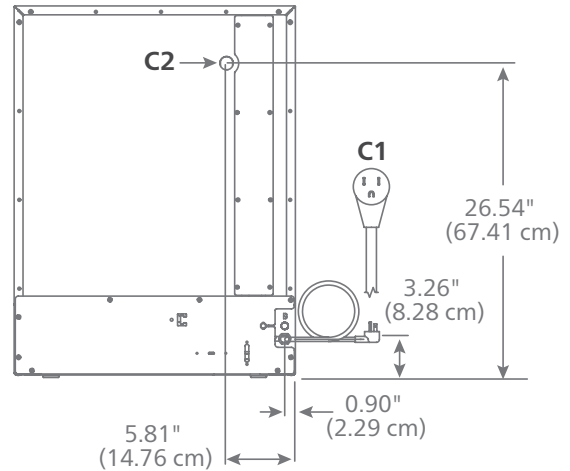
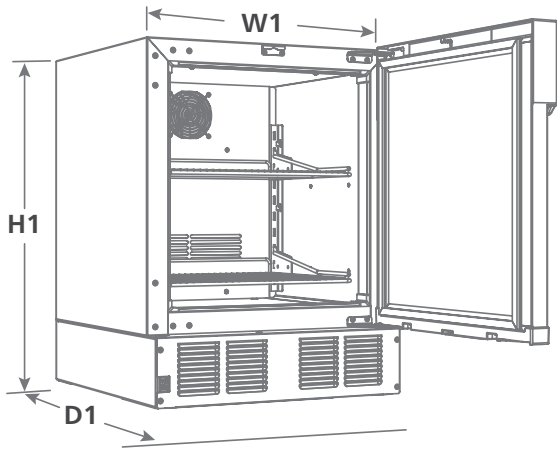

## Specification

Nominal capacity	4.5 cu ft (127 L)
Ventilation clearance	0.00" for top, side and back clearance

### Exterior

<b>W1</b> Width	23.75" (60.3 cm)
<b>D1</b> Depth cabinet	25.62" (65.1 cm)
Depth with façade	27.00" (68.6 cm)
<b>H1</b> Height	31.52" (80.1 cm)
Height with casters	34.02" (86.4 cm)
Door swing	24.00" (61.0 cm) from front of cabinet, 90° from closed

### Interior

Width	19.75" (50.2 cm)
Depth	18.32" (46.5 cm)
Height	21.54" (54.7 cm)
Storage system	(2) 18.10" x 19.10" (46.0 cm x 48.5 cm) epoxy-coated wire shelves

### Door configurations

Door	solid, foamed stainless 23.81" x 25.21" x 1.63" (60.5 cm x 64.0 cm 4.0 cm)
Door lock	cylinder lock
Door handle	molded into front façade
Door hinges	top and bottom mount, self-closing, right or left
Gasket	magnetic

### Electrical

<b>C1</b> 115 V/60/1 electrical	1.5 full load amps, NEMA 5-15P 90° hospital-grade plug, low profile, SJT, 16 AWG, 8' (2.4 m) cord
Maximum size of branch circuit overcurrent device	15 amps dedicated circuit

### Controls

Temperature display	REF5i: standard 7 segment LED REF5i-T: 7" capacitive touchscreen
Battery back-up on -KP (keypad) and -T (touchscreen) models only	rechargeable SLA 12V battery
<b>C2</b> 3rd party probe access	rear access port
Factory preset	4.4 C
Date and time (REF5i-T models only)	programmable
Controller security (REF5i-T models only)	choose "on" or "off" — 4 digit password to prevent interface setting/selection changes
Product simulation bottle	(1) 60 ml
Programmable operating range	2.2 to 10 C (36 to 50 F)

---

## Alarming

High and low product temperature alarm	audible and visual, user programmable set points in C or F
Probe error alarm	audible and visual — product temperature probes, refrigeration and defrost
Alarm mute	user selectable
Alarm volume	0 -10 adjustable
Min/max temperature log	shows highest and lowest product temperature since last reset occurred
Alarm output	12V DC On/Off, located on back panel

---

## System performance

Refrigerant and charge	R600a refrigerant, 1.4 oz charge
Energy consumption	0.57 kWh/day
Nominal heat rejection <sup>1</sup>	313 BTU/hr (92 W)
Max heat rejection	788 BTU/hr (231 W)

---

## Shipping

Shipping size W x D x H	30.00" x 33.00" x 50.00" (76.2 x 83.8 x 127.0 cm)
Approximate net weight	127 lb (57.7 kg)
Approximate ship weight	162 lb (73.5 kg)

NOTE: For indoor use only

<sup>1</sup> Nominal heat rejection means heat rejection from a refrigerator in a 75 F (24 C) ambient with proper ventilation, an empty cabinet, default settings, default defrost schedules/durations, and nominal supply 115-120 VAC.

---

## SHORT FORM SPECS:

Infinity Series undercounter refrigerator with variable capacity compressor with 4.5 cu ft (127 L) of nominal capacity and solid stainless steel door. For freestanding use or undercounter use, fits below 34.00" (86.4 cm) ADA countertops without casters. Includes (2) epoxy-coated wire shelves, adjustable in 1/2" increments. Each unit comes standard with a quick-connect NTC probe with one-year certificate of NIST-traceable calibration. Environmentally responsible R600a forced-air cooled refrigeration system. Top-mounted controls display product temperature in user-selectable C or F. Integral high and low temperature alarming. Storage area insulated with CARB compliant non-HFC foam. 8' (2.4 m) power cord with NEMA 5-15 90° hospital-grade plug. UL certified to meet NSF/ANSI 456 standard for vaccine storage. ENERGY STAR certified.

ENERGY STAR and the ENERGY STAR mark are registered trademarks owned by the U.S. Environmental Protection Agency.

INFINITY SERIES is a trademark of Follett Products, LLC.

FOLLETT and FOLLETT HEALTHCARE are registered trademarks of Follett Products, LLC, registered in the US.

Follett reserves the right to change specifications at any time without obligation.

---

## Infinity Series undercounter refrigerators

1120-20260407 | © Follett Products, LLC

801 Church Lane | Easton, PA 18040, USA  
1.800.523.9361 | 1.610.252.7301 | folletthealthcare.com

