

Ice Manager™ diverter valve system

IMDV-2CM series



Ice Manager Control Panel

Features:

The Ice Manager diverter valve system automatically delivers ice from ONE Follett Horizon Elite™ ice machine to TWO separate dispensers or bins. The system includes a control panel, diverter valve, and components to connect two ice storage units.

RIDE® remote ice delivery equipment

- deliver ice automatically through a tube to where you need it, instead of manually transporting
- reduce handling to provide more sanitary ice and prevent safety issues for employees and customers
- install ice machine and diverter valve up to 75' (22.9 m) away from the bin or dispenser
- create a more aesthetically appealing dining area with less heat and noise around your customers

Flexibility with a wide choice of bins and dispensers

- Follett ice storage bins and Ice Transport Systems (ITS)
- Follett Vision™ low-profile ice and beverage dispensers
- countertop ice and beverage dispensers manufactured by others (see approved list on page 2)
- other ice storage containers (contact factory)

Efficient use of equipment

- fill two dispensers or bins with only one ice machine
- reduce the number of ice machines in your operation, or eliminate manual filling
- keep one machine running more efficiently instead of two machines that may idle frequently
- service and maintain only one machine instead of two

Factory-arranged installation and start-up

- turn-key system installation with factory-trained installers
- full operational demonstration to end-user

Warranty

- 3 years parts and labor on all components

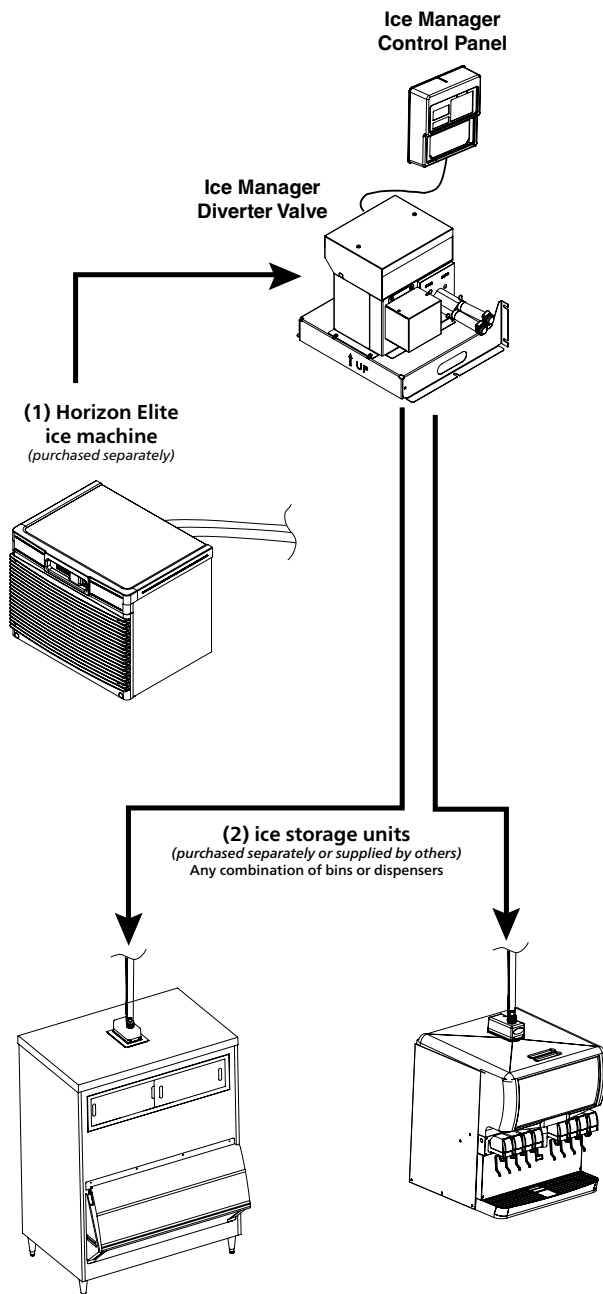

Configuring the Ice Manager diverter valve system

1. Evaluate site for location of equipment

Required clearances

- Refer to dispenser or bin specifications for required clearances
- Refer to dimensional drawings on page 4 for required clearances for the Ice Manager diverter valve system

Follett Horizon Elite ice machine

- 10' (3 m) distance from Horizon Elite ice machine to diverter valve
- Refer to specification sheet 1061, 1062, 1107, 1063, 1064, 1066 or 3311 for utility requirements and dimensions

Diverter valve

- 8' (2.4 m) maximum distance from diverter valve module to electric outlet
- 75' (22.9 m) maximum distance from diverter valve to receptacles
- Drain required, 15' (4.6 m) of 3/8" ID drain tube provided

Control panel

- 30' (9.2 m) maximum distance from control panel to diverter valve

2. Determine length of ice transport tube

Use the following guidelines to determine length of the ice transport tube run from the diverter valve to each receptacle.

- Ice transport tube can be ordered in lengths of 10' (3 m), 35' (10.7 m) or 80' (24.4 m). Include any bends and turns needed to connect components when calculating the length.
- Maximum vertical rise of ice transport tube – 10' (3 m)
- Horizontal run should be pitched so that melt water drains back to the ice machine. Ice transport tube run must have 1/4" per foot pitch.
- No dips or traps in the tube run

3. Placing an order

When submitting a purchase order, select one IMDV-2CM option from Section 1 and two transport tube lengths from Section 2.

Section 1: Select one of the following IMDV-2CM options (includes control panel, diverter valve and two sensor distribution units). See chart below for approved receptacles.

_____ For two bins or dispensers: item# 01547975

_____ For one Vision ice and beverage dispenser and one bin or dispenser or two Vision ice and beverage dispensers: item# 01562206

Note: For each new or existing Vision ice and beverage dispenser you must order integration kit, item# 00185165 for VU155 models or item# 00185173 for VU300 models.

Section 2: Select the ice transport tube length for each receptacle (two total):

_____ 10' (3 m) – Item# 01545755 _____ 35' (10.7 m) – Item# 01562214 _____ 80' (24.4 m) – Item# 01545789

Approved receptacles

| Bins | | | |
|--|----------------------------------|--------------------------------------|---------------------------------|
| New Follett ice storage bin or transport system. See form# 4025 for models. When ordering the bin, specify bin top to be cut for Ice Manager diverter valve system. If ice machine will be top mounted on bin, see mounting options on page 3. | | | |
| Existing Follett ice storage bin or transport system. Requires replacement top cut for Ice Manager diverter valve system. See form# 4025 for bin top item numbers. If ice machine will be top mounted on bin, see mounting options on page 3. | | | |
| Dispensers ¹ | | | |
| Coca-Cola Freestyle 9000 ² | Cornelius ED/DF250 Series | Lancer FS-16N/FS-22N/FS-30N/FS-44N | Servend FRP-250 |
| Coca-Cola Freestyle 7000 ^{2,3} | Cornelius ED/DF300 Series | Lancer Sensation 30"/44" | Servend MD150/MD175/MD200/MD250 |
| Coca-Cola Freestyle 9100 ^{2,4} | Cornelius IDC215 | Lancer Touchpoint | Servend MDH302/MDH402 |
| Cornelius ED/DF150 Series | Cornelius IDC255/Pro/Fast Gate | Lancer Bevariety | Servend SV175/SV200/SV250 |
| Cornelius ED/DF175 Series | Cornelius Flavor Fusion/Overload | Lancer Bold 30i | |
| Cornelius ED/DF200 Series | Lancer 4500-22N/4500-30N | Pepsi Spire 3.0/5.0/4.1 ⁵ | |
| ¹ Consult with dispenser provider to be sure the dispenser is ready to dispense nugget ice. | | | |
| ² Consult with Coca-Cola and Follett to qualify application prior to ordering. | | | |
| ³ Requires DVF30 top kit ordered separately from Follett and top adapter kit 46412 and ice kit 46430, which must be ordered from Coca-Cola. | | | |
| ⁴ Requires DVF26 top kit ordered separately from Follett. | | | |
| ⁵ Approved only for Pepsi Spire 3.0, 5.0 and 4.1 designed for top mount ice machines. Requires DVP24 top kit for 3.0 and DVP30 top kit for 5.0 and 4.1, ordered separately from Follett. For manual fill versions of Pepsi Spire 3.0, 5.0 and 4.1, contact factory. | | | |
| Vision Ice and Beverage Dispensers | | | |
| New Follett Vision VU155 or VU300 ice and beverage dispenser. See form# 4025 for models. Requires integration kit, item# 00185165 for VU155 models or item# 00185173 for VU300 models. | | | |
| Existing Follett Vision VU155 ice and beverage dispenser; serial# must be greater than B50001. Requires integration kit, item# 00185165. | | | |
| Existing Follett Vision VU300 ice and beverage dispenser; serial# must be greater than B50005. Requires integration kit, item# 00185173. | | | |

Ice machine selection and mounting options

3. Select Horizon Elite ice machine model

Refer to the model configuration table below to determine the Horizon Elite ice machine that will best suit your needs.

For additional information and specifications, refer to form# 1061, 1062, 1107, 1063, 1064, 1066 or 3311.

| Item number | Width in (cm) | Depth in (cm) | Height in (cm) | Production capacity lb (kg)* | | Condensing unit | Voltage |
|-------------|---------------|---------------|----------------|-------------------------------------|-------------------------------------|--|--------------|
| | | | | 90 F air 70 F water (32/21 C) | 70 F air 50 F water (21/10 C) | | |
| D710A | 22.70 (57.7) | 24.50 (62.2) | 21.25 (54.0) | 586 (266) | 759 (345) | air-cooled, self-contained condenser | 115/60/1 |
| C1010A | 29.15 (74.0) | 23.25 (59.1) | 22.50 (57.2) | 765 (347) | 1061 (482) | air-cooled, self-contained condenser | 208-230/60/1 |
| D1010R | 22.70 (57.7) | 22.50 (57.1) | 21.25 (53.9) | 758 (344) | 978 (444) | air-cooled, for connection to remote condenser (sold separately) | 115/60/1 |
| C1414A | 29.16 (74.0) | 25.13 (63.8) | 22.54 (57.2) | 1132 (514) | 1379 (626) | air-cooled, self-contained condenser | 208-230/60/1 |
| C1412W | 29.16 (74.0) | 24.51 (62.2) | 22.54 (57.2) | 1015 (461) | 1274 (578) | water-cooled, self-contained condenser | 208-230/60/1 |
| D1410R | 22.70 (57.7) | 24.50 (62.2) | 21.25 (53.9) | 1083 (492) | 1372 (623) | air-cooled, for connection to remote condenser (sold separately) | 115/60/1 |
| D1412R | 22.70 (57.7) | 24.50 (62.2) | 21.25 (53.9) | 1138 (614) | 1371 (622) | air-cooled, for connection to remote condenser (sold separately) | 115/60/1 |
| D1810R | 22.70 (57.7) | 23.70 (60.2) | 22.50 (57.2) | 1420 (645) | 1784 (810) | air-cooled, for connection to remote condenser (sold separately) | 115/60/1 |
| D2110R | 22.70 (57.7) | 23.70 (60.2) | 22.50 (57.2) | 1634 (741) | 2039 (925) | air-cooled, for connection to remote condenser (sold separately) | 115/60/1 |

* For water-cooled ice machines, standard conditions for capacity rating are 90 F condensing water temperature / 70 F potable water temperature or 70 F condensing water temperature / 50 F potable water temperature.

4. Choose Horizon Elite series ice machine mounting option

Mounting options:

| Wall Mount Bracket | Item number |
|---|-------------|
| 1010A, 1414A, 1412W | 01085455 |
| 710A, 1010R, 1410R, 1412R, 1810R, 2110R | 00997098 |
| Machine Stand | Item number |
| 1010A, 1414A, 1412W | 01085463 |
| 710A, 1010R, 1410R, 1412R, 1810R, 2110R | 00997080 |

Top Mount on Follett ice storage bin or transport system

Required clearances

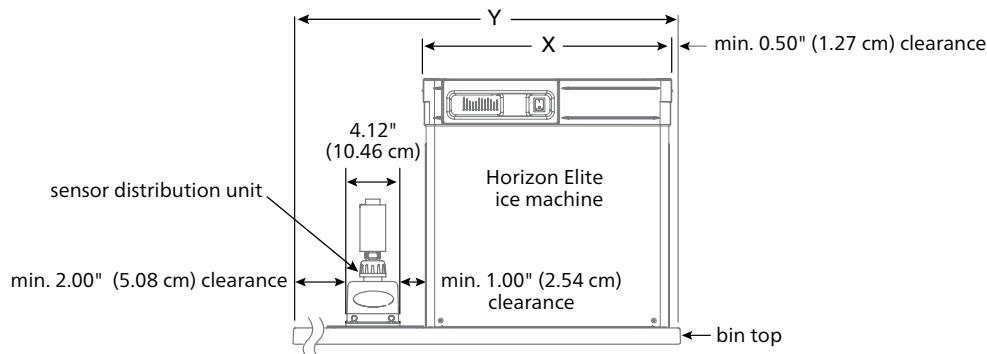

Note: For 30.00" (76.2 cm) Follett bin, sensor distribution unit may be placed behind ice machine.

New bin, see form# 4025 for models.

When ordering bin, specify bin top to be cut for Ice Manager diverter valve system and ice machine.

Existing bin, see form# 4025 for bin top listing.

Requires replacement top cut for Ice Manager diverter valve system and ice machine when ordering.

Other

Specify what the Horizon series ice machine will be mounted on.

Required clearances for Ice Manager diverter valve system

Diverter valve

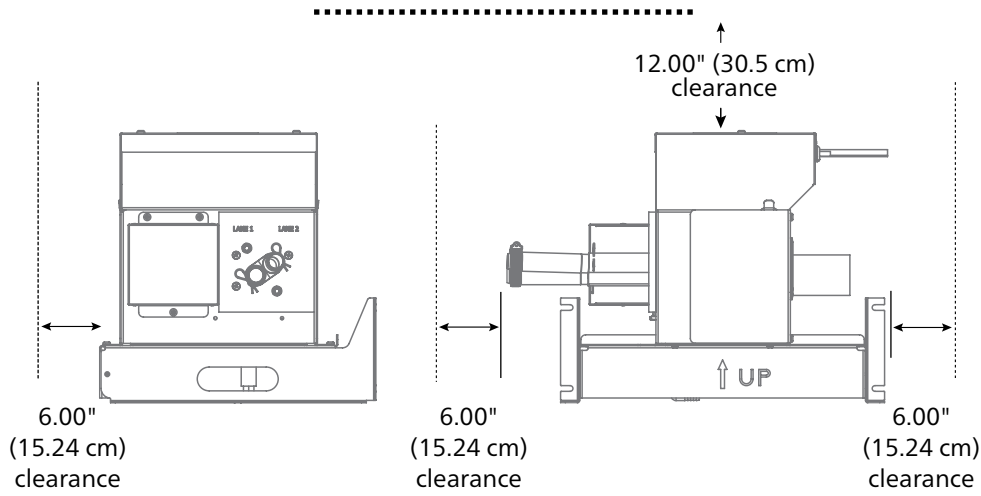

Sensor distribution unit

(bins and ice and beverage dispensers only)

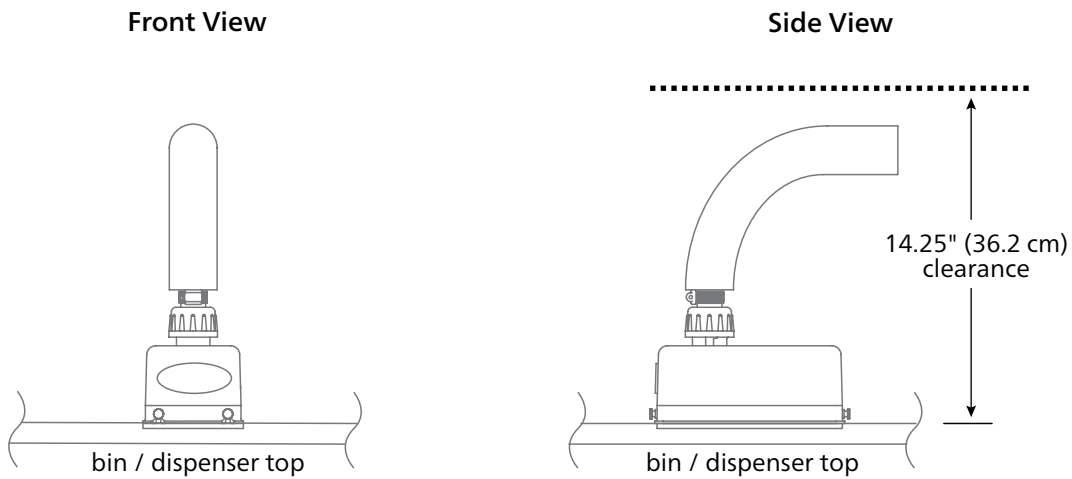

Insulated transport tube

(RIDE applications)

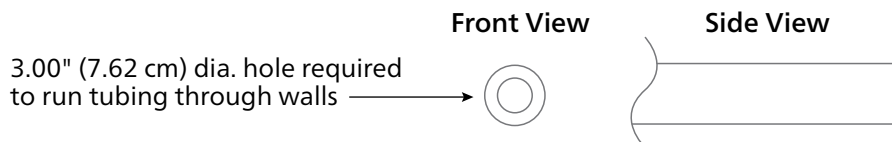

Specification

Ice type – Chewblet®

Control panel

| | |
|-----------------------------------|-------------------------------------|
| W1 Width of control panel | 12.00" (30.5 cm) |
| D1 Depth of control panel | 3.75" (9.52) |
| H1 Height of control panel | 12.50" (31.8 cm) |
| Connections | 30' (9.2 m) cable to diverter valve |

Diverter valve with mounting bracket

| | |
|------------------------------------|---|
| D2 Depth of diverter valve | 14.50" (36.8 cm) |
| W2 Overall width | 19.82" (50.3 cm) |
| W3 Width of bracket | 16.00" (40.6 cm) |
| H2 Height of diverter valve | 14.15" (35.9 cm) |
| Connections | 8' (2.4 m) cord and plug, 15' (5 m) drain tubing |
| Drain | 3/8" NPT barbed drain fitting |
| Electrical | 1.5 amps, 8' (2.4 m) cord, NEMA 5-15 plug |

Sensor distribution unit

| | |
|---|------------------|
| W4 Width of distribution sensor | 4.12" (10.46 cm) |
| D3 Depth of distribution sensor | 7.75" (19.68 cm) |
| H3 Height of distribution sensor | 3.50" (8.89 cm) |

General information

| | |
|--|--|
| Operating temperature | 40 - 120 F (4 - 49 C), relative humidity not to exceed 55% |
| Net weight of Ice Manager | 26 lb (12 kg) |
| Approximate ship weight of Ice Manager with ice transport tube | 142 lb (64 kg) |
| NOTE: For indoor use only | |

SHORT FORM SPECIFICATION:

Ice Manager diverter valve system automatically directs ice delivery to two separate bins or dispensers, utilizing sonic sensors to control the ice level. Ice machine to be Follett Horizon Elite model _____

IMDV-2CM:

____ Diverter valve, control panel and two sensor distribution units for bins or dispensers – item# 01547975

____ Diverter valve, control panel, one sensor for Vision ice and beverage dispenser and one sensor distribution unit for bin or dispenser or two Vision ice and beverage dispensers – item# 01562206

Ice transport tube length 1 _____

Ice transport tube length 2 _____

Dimensional drawing

Control panel

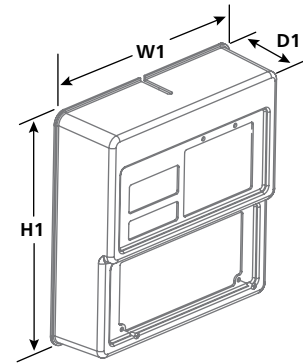

Diverter valve with mounting bracket

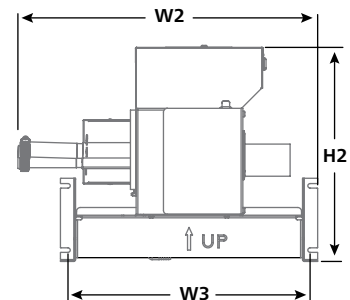
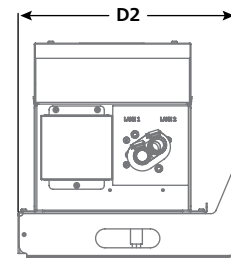

Sensor distribution unit

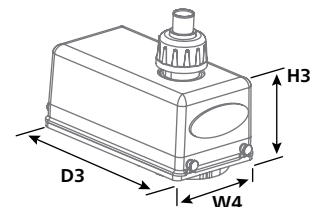

HORIZON ELITE, ICE MANAGER and VISION are trademarks of Follett Products, LLC. CHEWBLET and FOLLETT are registered trademarks of Follett Products, LLC, registered in the US. Follett reserves the right to change specifications at any time without obligation. Certifications may vary depending on country of origin.