

## Installation Instructions

### Description

Batteries operate the keypad lock during a loss of power.

### Installation

1. Provide power to the unit and turn the power switch to the **ON** position.
2. Open the door using the keypad lock and prop the door open so it doesn't close during the battery installation. Keypad instructions can be found in the Installation, Operation and Service manual on page 11.
3. Turn power switch to the **OFF** position or unplug the unit from the power supply.
4. Remove the four screws (**Fig. 1.1**) on the kick panel at the bottom of the unit.
5. Remove the kick panel and slide the panel to the right of the refrigerator.  
**Note:** Take care when removing, some wires are connected to the kick panel (**Fig. 1.2**).
6. Find the control module on the left-hand side of the unit, just to the left of the condenser.
7. Open the Velcro strap (**Fig. 1.3**) that holds the battery pack and the battery connector.
8. Connect the battery connector with the black and red wires to the top of the battery pack.
9. Place the battery pack back in place on the control module and tighten the Velcro strap around the battery pack.
10. Re-install the kick plate.
11. Close the door and check to make sure that the wire on the hinge side of the door is not kinked or pinched.
12. Test operation of the keypad lock while the power to the unit is **OFF** to confirm back-up battery connection.
13. Turn the power switch **ON** or plug the unit back into the power supply.

Fig. 1

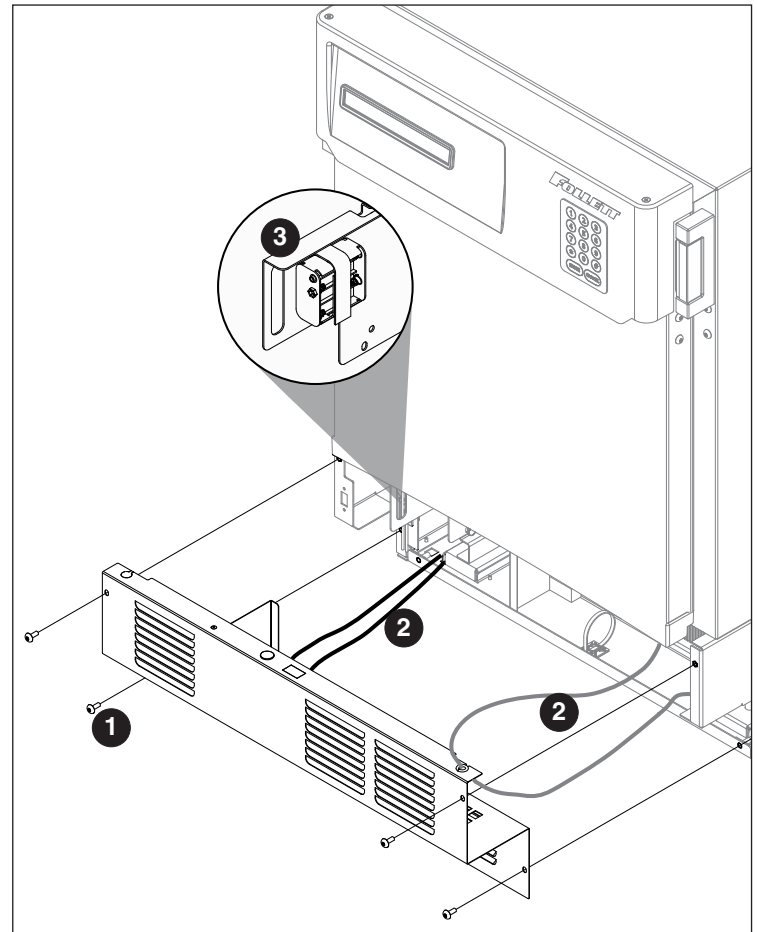

Follett is a registered trademark of Follett Corporation, registered in US.

---



801 Church Lane • Easton, PA 18040, USA  
Toll free (877) 612-5086 • +1 (610) 252-7301  
[www.follettice.com](http://www.follettice.com)

01065234R00  
© Follett Corporation 5/14