

## Installation Guide

Please visit <https://www.follettice.com/technicaldocuments>  
for the Operation and Service manual for your unit.

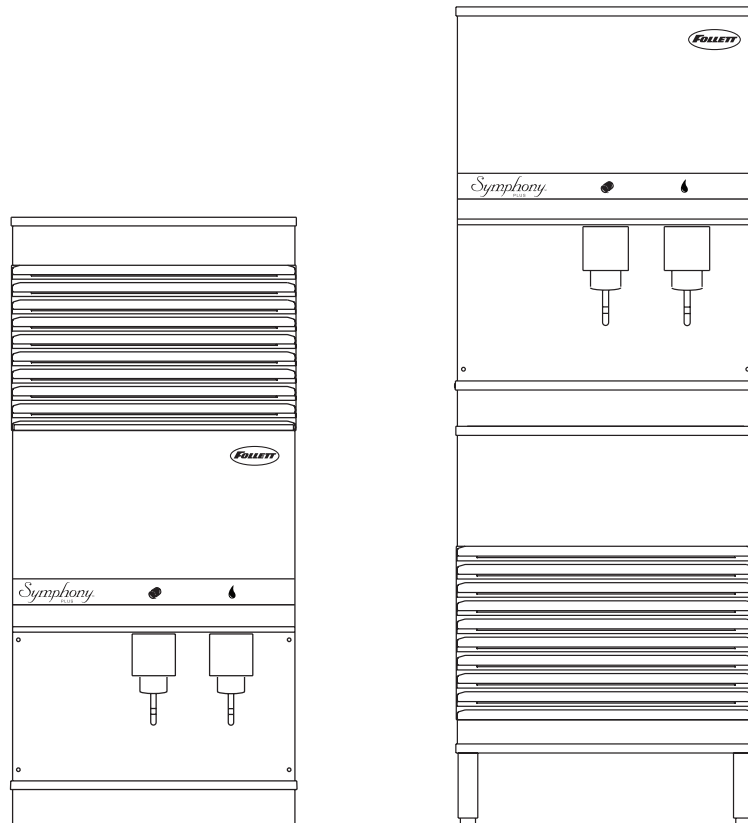

### Welcome to Follett

Follett equipment enjoys a well-deserved reputation for excellent performance, long-term reliability and outstanding after-the-sale support. To ensure that this equipment delivers that same degree of service, review this guide carefully before you begin your installation.

Should you have need technical help, please call our Technical Service group at (877) 612-5086 or (610) 252-7301.

Please have your model number, serial number and complete and detailed explanation of the problem when contacting Technical Service.

### Getting Started

After uncrating and removing all packing material. Inspect the equipment for concealed shipping damage. All freight is to be inspected upon delivery. If visible signs of damage exist, please refuse delivery or sign your delivery receipt "damaged." Follett Customer Service must be notified within 48 hours. Wherever possible, please include detailed photos of the damage with the original packaging so that we may start the freight claim process.



## CAUTION!

- Do not tilt unit further than 30° off vertical during uncrating or installation.
- Dispenser bin area contains mechanical, moving parts. Keep hands and arms clear of this area at all times. If access to this area is required, power to unit must be disconnected first.
- Follett recommends a Follett water filter system be installed in the ice machine inlet water line (standard capacity #00130229, high capacity #00978957, carbonless high capacity #01050442).
- Prior to operation clean the dispenser in accordance with instructions found in this manual.
- Ice is slippery. Be sure counters and floors around dispenser are clean, dry and free of ice.
- Do not block right side air intake or top air exhaust.

## Specifications

### Electrical

- Freestanding and countertop models (110FB425A/W, 110CT425A/W) require a dedicated circuit.

	Total system	Max. circuit
Basic electrical: 115 V/60 Hz/1 phase	11.0A	20A

- Dispensers and ice machines are supplied with 7-foot power cord with NEMA 5-15 hospital-grade plug. Connect to a dedicated 15A circuit.

Model	Electrical connection	Circuits required
110FB425A/W	cord & plug provided	115/60/1, 15A max. fuse size
110CT425A/W	cord & plug provided	115/60/1, 15A max. fuse size

### Ambient

Air temp*	100 F/38 C Max.	50 F/10 C Min. (Best performance below 80 F/27 C)
Water temp†	90 F/32 C Max.	45 F/7.2 C Min. (Best performance below 70 F/21 C)
Water pressure (psi/bar)	70/5 Max.	10/0.7 Min.

\* Ambient air temperature is measured at the air-cooled condenser coil inlet.

† Ambient water temperature is measured in the ice machine reservoir.

### Plumbing

	110CT with integral ice machine	110FB with ice machine in base
Dispenser drain	3/4" MPT	3/4" MPT
Ice machine drain	3/4" MPT	3/4" MPT
Dispenser water inlet	3/8" FPT	3/8" FPT
Ice machine water inlet	3/8" FPT	—
Cond. inlet – w/c only	3/8" FPT	3/8" FPT
Cond. drain – w/c only	3/8" FPT	3/8" FPT

**Note:** Water shut-off recommended within 10 ft (3 m) of dispenser. Drain to be hard-piped and insulated. Maintain at least 1/4" per foot (20 mm per 1 m) run of slope.

### Ventilation clearances

- 110CT425A/W:** 6" (15.2 cm) required at top.  
**Note:** 6" (15.2 cm) at each side advised for service.
- 110FB425A/W:** 4" (10.2 cm) required at rear.  
**Note:** 12" (30.5 cm) at top advised for service.

### Approximate shipping weight

- 290 lb (132 kg), base stand: 140 lb (64 kg)

## Installation

### Before you begin

- All dispensers must be installed level in both directions to ensure proper operation.
- All countertop dispensers provide the option of taking utilities out the bottom or back of the dispenser. See counter cut-out (**Fig. 2**) for bottom exiting utilities on units with and without drain pans. For installations where utilities will exit through back of dispenser, refer to back view drawings.

### Installing freestanding dispensers

1. Position dispenser in desired location and adjust legs to level in both directions.
2. Connect water supply to 3/8" FPT fitting on back of dispenser (**Fig. 1**).
3. Connect separate drain lines to 3/4" MPT dispenser drain fitting, and 3/4" MPT ice machine drain fitting on back of dispenser.
4. Run drain lines to wall or floor drain. If ice machine drain fitting is below an intended wall drain, a condensate pump must be used.
5. If ice machine is a water-cooled unit, connect water-cooled condenser supply line to 3/8" FPT condenser inlet fitting on back of dispenser.  
**Note: Do not run condenser supply water through ice machine water filter system.**
6. Connect condenser drain line to 3/8" FPT condenser outlet fitting on back of dispenser.  
**Important: Do not connect condenser drain line to any other drain lines.**
7. Plug dispenser into 15A rated NEMA 5-15 circuit.
8. Remove front cover of base section by removing two screws at bottom corners of cover. Allow cover to drop approximately 3/8" (5 mm) and pull forward.
9. Turn on water supply and check for leaks.

**Fig. 1 – Rear connections, freestanding models**

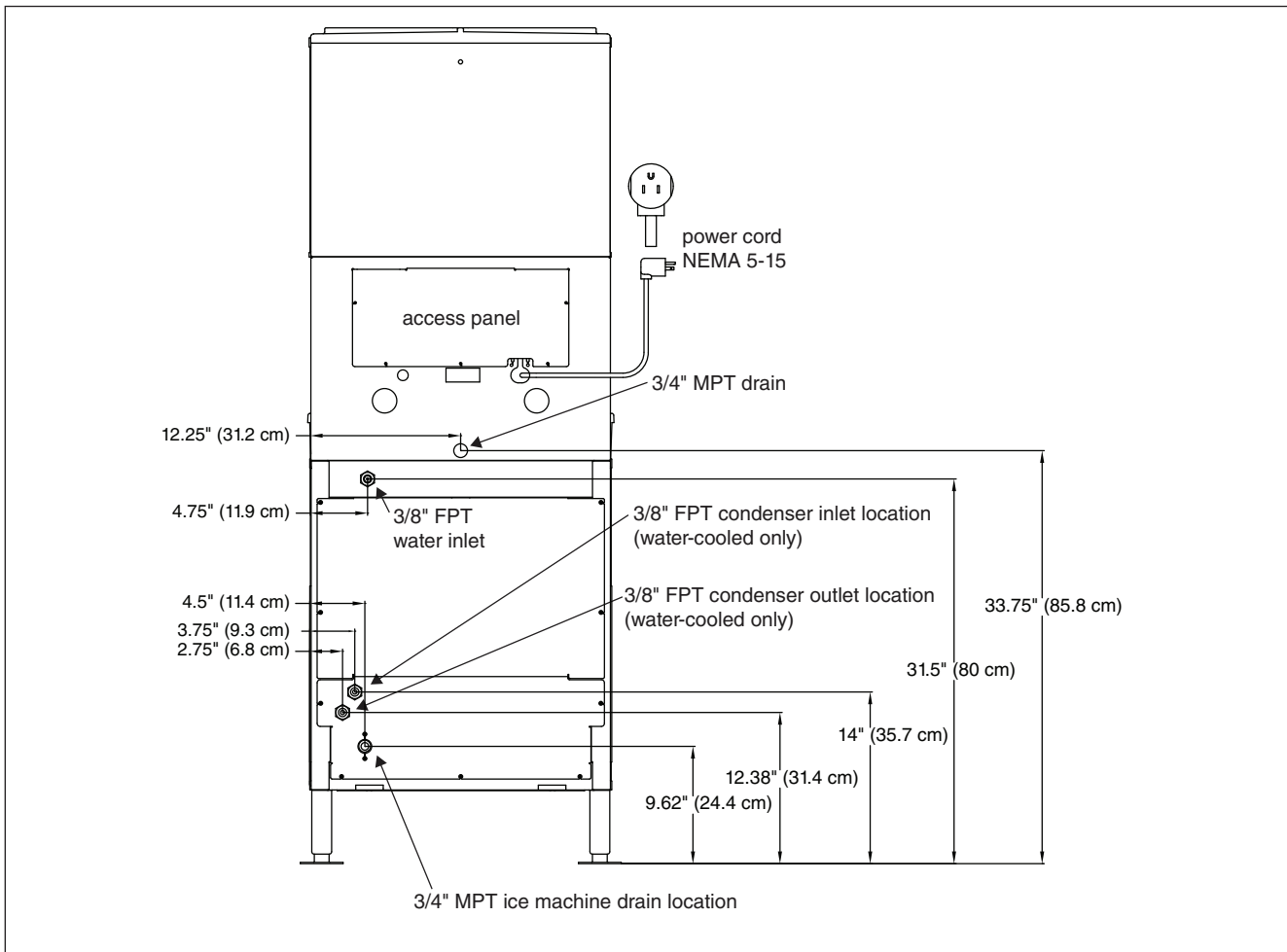

10. Remove top front cover by removing two screws at bottom corners of cover. Lift cover slightly and pull forward.
11. If dispenser is equipped with SensorSAFE remove protective plastic coating from dispense sensor labels.
12. Turn on dispenser power and bin signal rocker switches. Check dispenser and ice machine operation.
13. Clean ice machine according to instructions in the Cleaning section. Discard ice made during cleaning process.
14. Turn off ice machine bin signal switch.
15. Remove dispenser hopper lid; clean dispenser according to instructions.
16. Turn ice machine bin signal switch on and replace front covers, securing with screws.

## Installing countertop dispensers



### CAUTION!

Dispensers with top mount ice machines cannot be mounted on legs. They must be bolted to counter. Use gloves when lifting ice machine to protect hands from sheet metal edges.

1. Position dispenser in desired location, mark dispenser outline on counter and remove dispenser.
2. Regardless of whether utilities will exit through back or bottom of dispenser, drill four (4) 3/8" holes in counter to anchor dispenser to counter (**Fig. 2**).

**Note:** *Follett countertop dispensers can have any or all utilities run directly through counter or out rear of dispenser. For dispensers with any utilities exiting through counter, make counter cut-out (**Fig. 2**).*

### 3. For utilities exiting through bottom only:

- (a) Make cut out as shown (**Fig. 2**).
- (b) Move drain fitting from back of dispenser and mount where shown (**Fig. 3**).
- (c) Cut drain tube to length and attach to barbed connection.
- (d) Move inlet water fitting from back of dispenser and mount where shown (**Fig. 3**).
- (e) Cut water tubing to length and re-insert into water fitting.

**Note:** Utility connections can be accessed through front of dispenser by removing stainless steel splash panel, or by removing access panel (**Fig. 4**) on back of dispenser.

**Fig. 2**

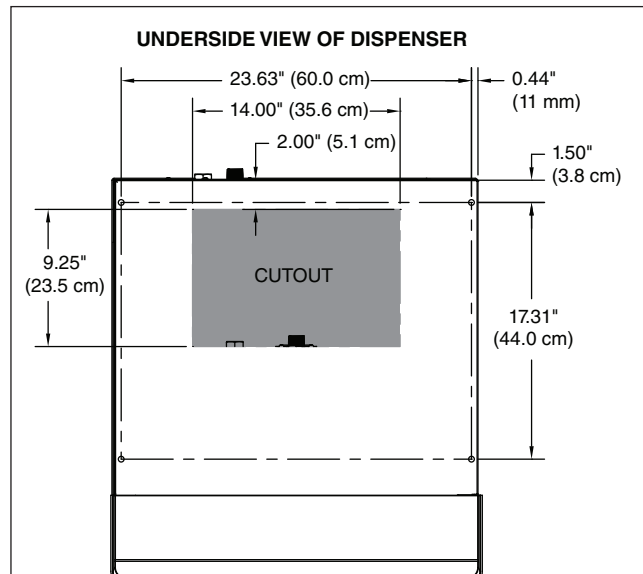

**Fig. 3 – Bottom exiting utilities (countertop units)**

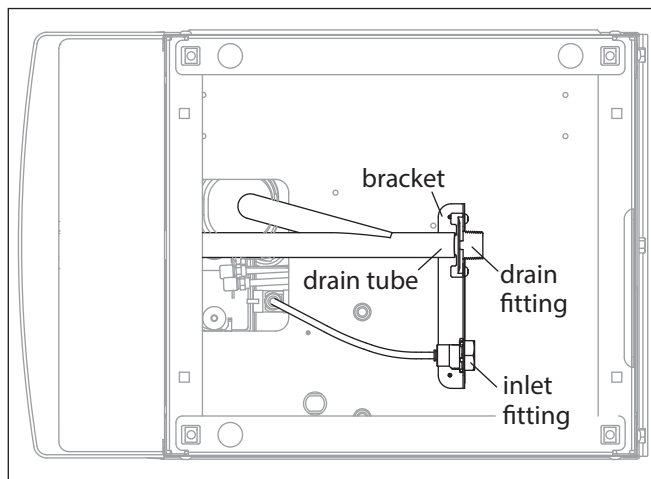

**Fig. 4 – Rear connections, countertop models**

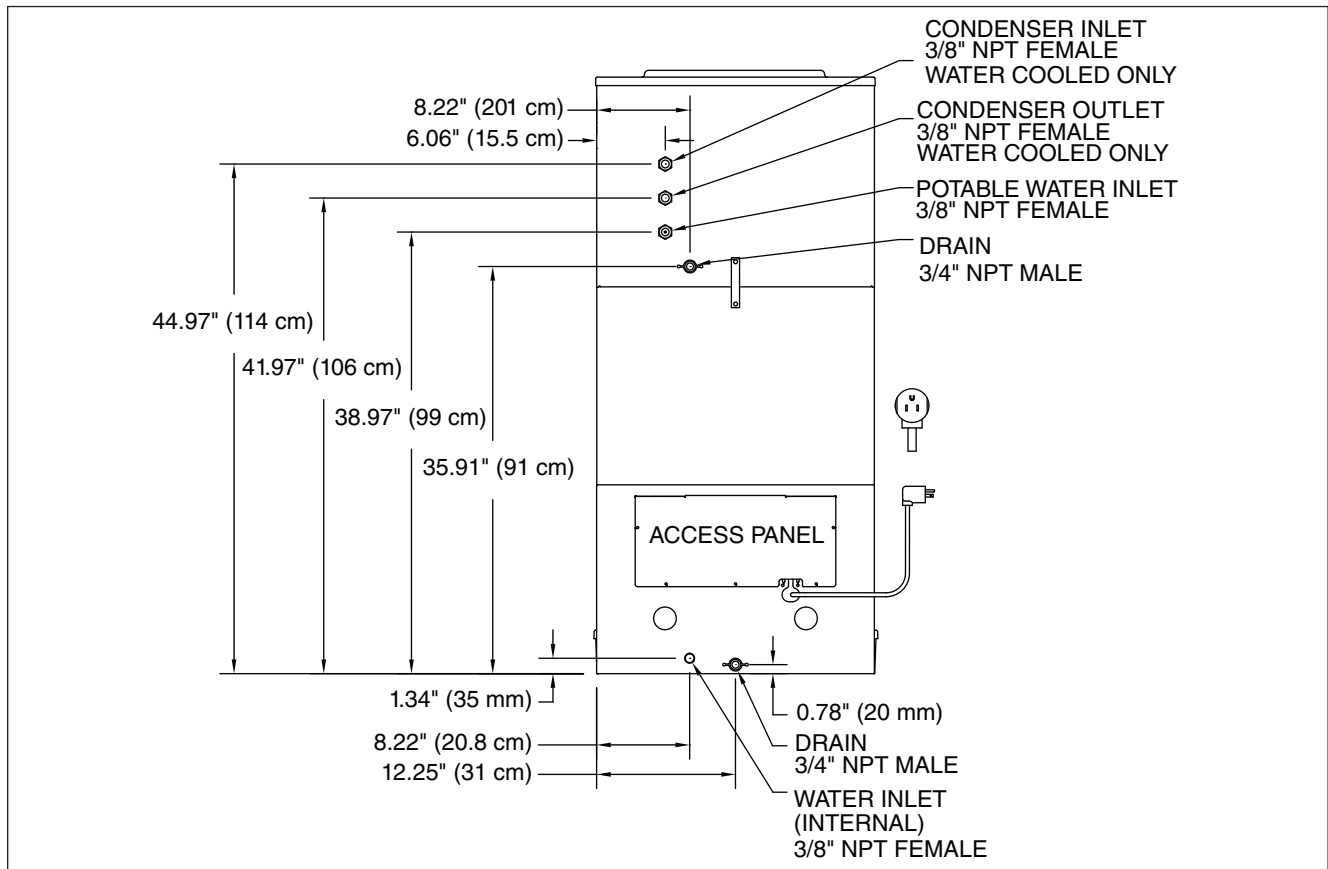

4. If power is to be supplied through counter cut-out, complete steps 6-9. If power is to be supplied through rear of dispenser, proceed to **step 10**.
5. Temporarily remove rear access panel (**Fig. 4**) from rear of dispenser.
6. Loosen junction box mounting screws. Lift junction box and power cord up until cord and mounting screws clear notches on rear panel of dispenser. Remove Phillips-head screws from right side of junction box.
7. Rotate junction box 90 degrees so that screw holes on right side of junction box align with holes on rear dispenser panel. Secure junction box to dispenser using Phillips-head screws.
8. Place power cord inside dispenser and replace access panel (**Fig. 4**) to rear of dispenser.  
**Note:** For dispensers to be installed with utilities connected through rear of dispenser, it may be easier to make preliminary connections before dispenser is set in place.
9. Apply a thick bead, approximately 1/4" (7 mm) diameter, of NSF listed silicone sealant (Dow-Corning® RTV-732 or equivalent) 1/4" (7 mm) inside marked outline of dispenser.
10. Carefully position dispenser on counter.
11. Remove four screws securing splash panel to front of dispenser and gently lay splash panel on counter. (Water line to solenoid valve can be disconnected from water inlet valve by pushing on ring at end of inlet fitting while pulling on tubing.)
12. Secure dispenser to counter with four 3/8" bolts (supplied by others).
13. Smooth excess sealant around outside of dispenser.

## Installing top mount ice machines

Models 110CT425A/W



Dispensers with top mount ice machines cannot be mounted on legs. They must be bolted to counter. Use gloves when lifting ice machine to protect hands from sheet metal edges.

1. Remove dispenser top front cover by removing two screws at bottom corners of cover, lifting cover slightly and pulling forward.
2. Remove ice machine compartment top and side panels.
3. Remove ice machine hold-down bracket from front of ice machine compartment.
4. Lift ice machine onto dispenser top and slide ice machine completely into position, compressor end first.
5. Reinstall hold-down bracket on front of ice machine with power cord and bin signal cords in notch. Do not cut or pinch cords.
6. Insert loose end of ice transport tube through bracket (on ice machine base) into hopper access hole. Tighten transport tube clamp screw to secure ice transport tube.
7. Connect plastic water supply line to water fill solenoid.

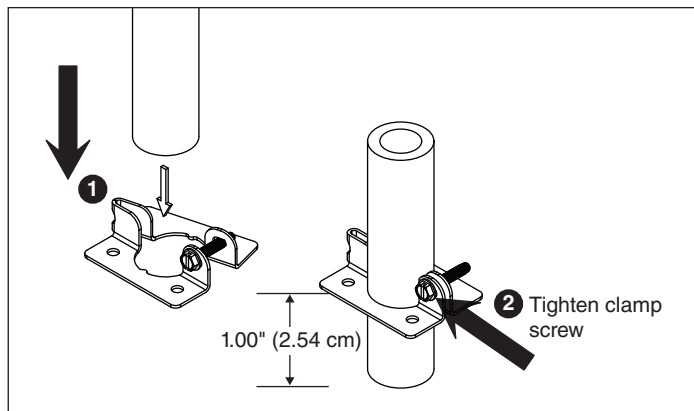



8. Connect molded drain tube to evaporator drain pan, purge solenoid and rear drain fitting.

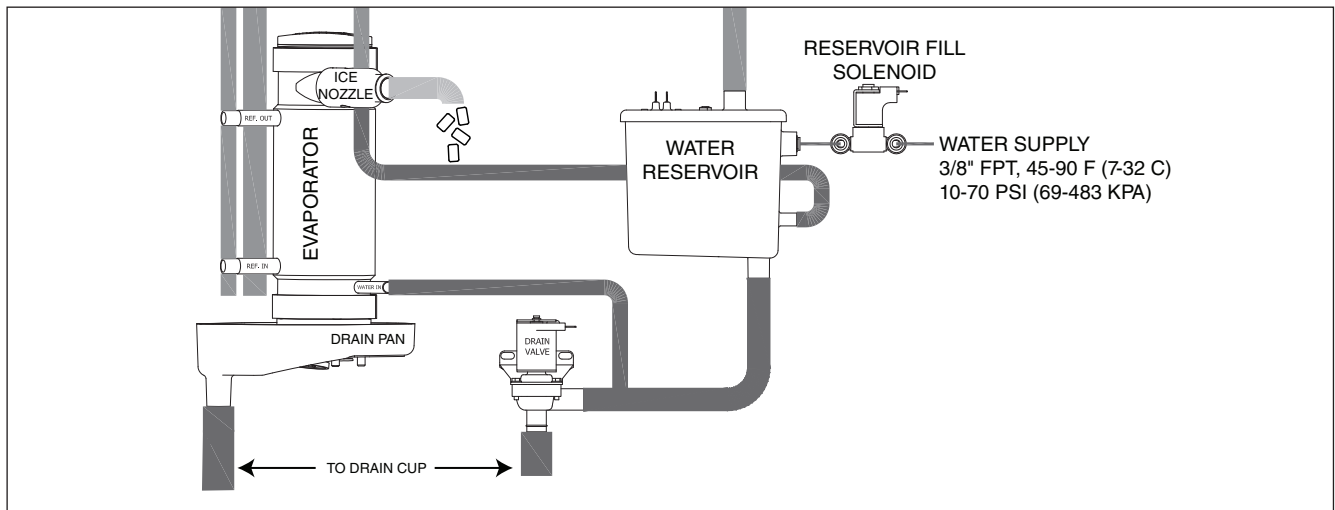

9. Connect dispenser bin signal cable to two-pin receptacle on the ice machine electrical box ① and connect the three-pin receptacle to the ice machine electrical box ②.

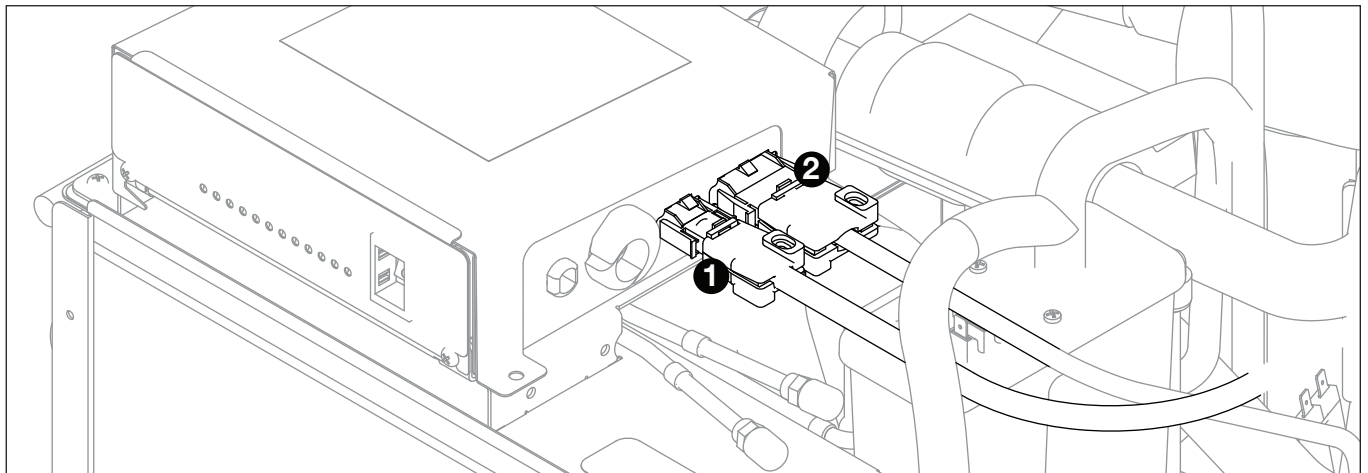

10. On dispensers equipped with water-cooled ice machines, connect condenser water supply and drain lines to condenser fittings on ice machine.
11. Turn on water supply and check for leaks.
12. Plug dispenser power cord into 15A rated NEMA 5-15 circuit.
13. If dispenser is equipped with SensorSAFE, remove protective plastic coating from dispense sensor labels.
14. Turn on power and bin signal rocker switches and test operation.
15. Clean ice machine following instructions in Cleaning section.
16. Remove dispenser hopper access lid and clean dispenser according to instructions.
17. Replace front cover and secure with screws. Installation is complete.

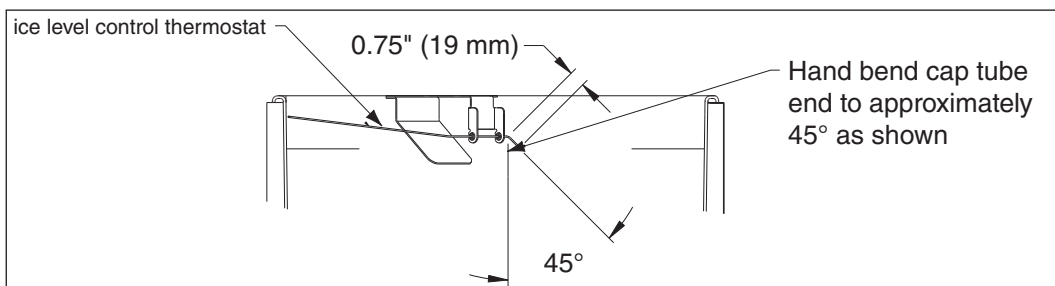

## Cleaning and sanitizing

Follett ice machines and dispensers, and their associated cleaning and sanitizing procedures, are designed for use with potable water sources. The presence, or suspected presence, of infectious agents may call for additional measures, including the replacement of components and more comprehensive disinfection measures. Follett recommends that these cleaning and sanitizing procedures be reviewed with the appropriate infectious agent subject matter experts to assure complete remediation.

Periodic cleaning of Follett's ice and water dispenser and ice machine system is required to ensure peak performance and delivery of clean, sanitary ice. The recommended cleaning procedures that follow should be performed at least as frequently as recommended and more often if environmental conditions dictate.

Follett recommends sanitizing the pressurized water lines prior to cleaning the ice machine/dispenser. Follett offers two kits: order P/N 01089572 when a Follett filter system with a pre-filter bowl is present, or P/N 01089580 when a Follett filter system is not present. Follow the instructions provided with the respective kits to sanitize the pressurized water lines immediately before cleaning the ice machine/dispenser.

Cleaning of the condenser can usually be performed by facility personnel. Cleaning of the ice machine system should be performed by your facility's trained maintenance staff or a Follett authorized service agent. Regardless of who performs the cleaning, it is the operator's responsibility to see that this cleaning is performed according to the schedule below. Service problems resulting from lack of preventive maintenance will not be covered under the Follett warranty.

### Recommended cleaning intervals\*

Symphony Plus	Frequency
Drain Line	weekly
Drain Pan/Drip Pan	weekly
Exterior, Water Station Tube	as needed
Condenser	monthly (air-cooled only)
Dispenser and Components	semi-annually
Ice Machine	semi-annually
Transport Tube	semi-annually
Ice Storage Area/Bin	semi-annually
Pressurized Water Sanitizing	semi-annually

\* Ice machine and dispenser must be cleaned prior to start-up.

### Weekly

#### CAUTION!

- Do not use solvents, abrasive cleaners, metal scrapers or sharp objects to clean any part of the dispenser.

#### Dispenser drain pan and drain line

- Pour 1 gal. (3.8 L) of hot tap water into drain pan to flush drains.

#### Splash panel front, SensorSAFE infrared dispensing

- Deactivate dispensing by pressing and releasing clean switch located on left side of unit under top front cover.
- Clean lens and splash panel front using a soft cloth and mild, non-abrasive, non-chlorine based cleaner.
- Reactivate dispensing by pressing and releasing clean switch again.

### Monthly

#### CAUTION!

- Do not use solvents, abrasive cleaners, metal scrapers or sharp objects to clean any part of the dispenser.

#### Condenser (air-cooled ice machine only)

- Use a vacuum cleaner or stiff brush to carefully clean condenser coils of lint and debris to ensure optimal performance.

## Semi-Annually (more often if conditions dictate)

- A cleaning procedure should always include both the ice machine and dispenser.
- Icemaking system can be cleaned in place.



### CAUTION!

- Wear rubber gloves and safety goggles (or face shield) when handling SafeCLEAN Plus™ and IMS-III solutions.
- Use only Follett approved cleaners.
- It is a violation of Federal law to use the Nu-Calgon® IMS-III solution in a manner inconsistent with its labeling.
- Do not use solvents, abrasive cleaners, metal scrapers or sharp objects to clean any part of the dispenser.

### Cleaning Tool Checklist

- (1 or 2) 1.5 gallon (or larger) plastic bucket
- (2) clean cloths
- Sanitary gloves
- Safety glasses
- (2) SaniSponge™ (P/N 00131524 - single sponge)
- SafeCLEAN Plus ice machine cleaner
- [OPTIONAL] Nu-Calgon IMS-III no-rinse sanitizer (P/N 00979674 – 16 fl oz. bottle)

**SafeCLEAN Plus Solution:** Follow the directions on the SafeCLEAN Plus packaging to mix 1 gal. (3.8 L) of Follett SafeCLEAN Plus solution. Use 100 F (38 C) water.

**[OPTIONAL] No-rinse Sanitizing Solution:** Follow the directions on the Nu-Calgon IMS-III packaging to mix 1 gal. (3.8 L) of IMS-III solution. Use 100 F (38 C) water.

## Ice Machine and Dispenser

### Cleaning Procedure

**Note:** Check drains and drain cup to ensure they are open and flowing freely.

1. If ice machine was running recently, ensure that the evaporator is completely free of ice before proceeding. If there is ice in the evaporator, complete steps 2-7 using only hot water to remove the ice, then begin Cleaning Procedure again.
2. Remove front cover and turn **OFF** bin signal switch.
3. Dispense all ice from storage hopper and discard.
4. Remove splash panel.
5. Press **CLEAN** switch. The **MAINTENANCE** light will turn on and the machine will drain. Wait for the **LOW WATER** light to turn on.
6. Remove lid from cleaning cup and fill (about 1 quart) until SafeCLEAN Plus solution completely fills the reservoir. Place lid back on cup. Save remainder of SafeCLEAN Plus solution.
7. **CLEANER FULL** light will turn on and machine will start cleaning cycle then rinse three times; this process takes approximately 15 minutes.
8. While ice machine is cleaning, clean dispenser as follows:
  - a. Turn **OFF** dispenser power.
  - b. Remove hopper lid.
  - c. Remove knurled nuts from front of storage hopper.
  - d. Remove stud assembly, baffle, wheel, and any remaining ice.
  - e. Remove dispense chutes from splash panel.
  - f. Submerge drain grille in SafeCLEAN Plus solution and allow to soak to remove any scale buildup.
  - g. Wipe inside of hopper lid, stud assembly, baffle, wheel, inside of storage area, dispense chutes, drain grille and drain pan with damp cloth wrung out in SafeCLEAN Plus solution. Thoroughly rinse all parts with damp cloth wrung out with clean water.

**Note:** To avoid possible damage to motor assembly, only use a damp cloth to clean storage hopper. Do not allow water to run through motor shaft hole in bottom of hopper.
9. When machine is finished cleaning, the **MAINTENANCE** light will turn off.

### Finish cleaning – SafeCLEAN Plus only

10. If the dispenser is not equipped with a Chilled Water Accessory, skip to **Step 11**.
  - a. Remove four screws securing splash panel.
  - b. Disconnect 3/4" (19 mm) drain line from bottom of chilled water canister.
  - c. Loosen (do not remove) screw securing front bracket of chilled water canister to bottom of dispenser hopper.
  - d. Rotate canister clockwise to release front bracket, then pull canister forward to disengage rear bracket.
  - e. Remove chilled water coil from canister and clean with cloth wrung out in SafeCLEAN Plus solution.
  - f. Wipe inside of chilled water canister with cloth wrung out in SafeCLEAN Plus solution.
  - g. Rinse all above items with damp cloth wrung out in clear water.
  - h. Reinstall chilled water coil into canister (rubber alignment grommet on coil tubing must be located outside chilled water canister to hold coil securely against canister wall).
  - i. Reinstall chilled water assembly on dispenser and tighten screw securing front bracket.
  - j. Reconnect 3/4" (19 mm) drain line to chilled water canister.
11. Reinstall dispense chutes, wheel, baffle, stud assembly and knurled nuts.
12. Remove top bearing insulation. Loosen Phillips-head screw on nozzle connected to evaporator. Remove nozzle from evaporator side only, leave other side of nozzle connected to transport tube.
13. Soak one SaniSponge in remaining SafeCLEAN Plus solution.
14. Insert the sponge soaked in cleaning solution into nozzle then insert a dry sponge into the nozzle.
15. Replace nozzle onto evaporator and tighten screw. Ensure drain is connected to reservoir and vent tubes are connected to evaporator drain pan. Replace top bearing insulation.
16. Turn **ON** bin signal switch. Wait for ice to push sponges through transport tube.
17. Collect sponges from ice storage bin.
18. Replace hopper lid, machine top, turn **ON** dispenser power and install front cover.
19. After 10 minutes, dispense all ice and discard.

### [OPTIONAL] Finish cleaning – No-rinse sanitizing with Nu-Calgon IMS-III

10. Press **CLEAN** switch. The **MAINTENANCE** light will turn on and the machine will drain. Wait for the **LOW WATER** light to turn on.
11. Remove lid from cleaning cup and fill (about 1 quart) until sanitizing solution completely fills the reservoir. Place lid back on cup. Save remainder of sanitizing solution.
12. **CLEANER FULL** light will turn on and machine will start sanitizing cycle then rinse three times; this process takes approximately 15 minutes.
13. While ice machine is sanitizing, clean dispenser as follows:
  - a. Wipe inside of hopper lid, stud assembly, baffle, wheel, inside of storage area, dispense chutes, drain grille and drain pan with damp cloth wrung out in sanitizing solution. Do not rinse off the sanitizing solution.  
**Note:** To avoid possible damage to motor assembly, only use a damp cloth to clean storage hopper. Do not allow water to run through motor shaft hole in bottom of hopper.
14. Reinstall dispense chutes, wheel, baffle, stud assembly and knurled nuts.
15. When machine is finished rinsing, the **MAINTENANCE** light will turn off.
16. If the dispenser is not equipped with a Chilled Water Accessory, skip to **Step 17**.
  - a. Remove four screws securing splash panel.
  - b. Disconnect 3/4" (19 mm) drain line from bottom of chilled water canister.
  - c. Loosen (do not remove) screw securing front bracket of chilled water canister to bottom of dispenser hopper.
  - d. Rotate canister clockwise to release front bracket, then pull canister forward to disengage rear bracket.
  - e. Remove chilled water coil from canister and clean with cloth wrung out in sanitizing solution.
  - f. Wipe inside of chilled water canister with cloth wrung out in sanitizing solution.
  - g. Do not rinse off the sanitizing solution.
  - h. Reinstall chilled water coil into canister (rubber alignment grommet on coil tubing must be located outside chilled water canister to hold coil securely against canister wall).
  - i. Reinstall chilled water assembly on dispenser and tighten screw securing front bracket.
  - j. Reconnect 3/4" (19 mm) drain line to chilled water canister.
17. Remove top bearing insulation. Loosen Phillips-head screw on nozzle connected to evaporator. Remove nozzle from evaporator side only, leave other side of nozzle connected to transport tube.
18. Soak one SaniSponge in remaining sanitizing solution. Insert the sponge soaked in sanitizing solution into nozzle then insert a dry sponge into the nozzle.
19. Replace nozzle onto evaporator and tighten screw. Ensure drain is connected to reservoir and vent tubes are connected to evaporator drain pan. Replace top bearing insulation.
20. Turn ON bin signal switch. Wait for ice to push sponges through transport tube.
21. Collect sponges from ice storage bin.
22. Replace hopper lid, machine top, and install front cover.
23. After 10 minutes, dispense all ice and discard.

### User Interface and Exterior Cabinet

- Clean stainless steel panels with stainless steel cleaner.

## Dispenser troubleshooting

### CAUTION!

- Disconnect power to unit before putting hands or arms in storage area or attempting any repair or service to equipment.

#### Before calling for service

1. Check that no ice is in the dispenser bin area.
2. Check that congealed ice is not causing a jam.
3. Check that all switches and circuit breakers are on.
4. Check that all drains are clear.

#### Lever model troubleshooting guide

Problem	Indicators	Corrective Action
Does not dispense ice.	<ol style="list-style-type: none"> <li>1. Power switch off or faulty.</li> <li>2. Faulty dispense switch.</li> <li>3. Wheel motor malfunction.</li> </ol>	<ol style="list-style-type: none"> <li>1. Check switch – turn on or replace if faulty.</li> <li>2. Replace switch.</li> <li>3. Check motor and capacitor and replace.</li> </ol>
Does not dispense water.	<ol style="list-style-type: none"> <li>1. Dispense switch contacts burned shut.</li> <li>2. Debris preventing valve from closing.</li> </ol>	<ol style="list-style-type: none"> <li>1. Replace water solenoid valve.</li> <li>2. Replace dispense switch.</li> <li>3. Check switch - turn on or replace if faulty.</li> </ol>
Water runs continuously.	<ol style="list-style-type: none"> <li>1. Faulty water solenoid valve.</li> <li>2. Faulty dispense switch.</li> <li>3. Power switch off or faulty.</li> </ol>	<ol style="list-style-type: none"> <li>1. Check switch and replace if faulty.</li> <li>2. Remove and clean valve.</li> </ol>
Dispense wheel rotates continuously.	Dispense switch contacts are burned out.	Replace dispense switch.
Ice machine runs continuously.	Faulty or incorrectly positioned bin stat.	Check for proper positioning. If stat does not open when ice is placed on capillary tube, replace stat.
Ice dispenses by itself.	<ol style="list-style-type: none"> <li>1. Baffle not adjusted properly.</li> <li>2. Faulty dispense switch.</li> </ol>	<ol style="list-style-type: none"> <li>1. See Adjustment Instructions in Operation and Service manual.</li> <li>2. Replace dispense switch.</li> </ol>
Not making ice.	<ol style="list-style-type: none"> <li>1. Dispenser is in sleep mode.</li> </ol>	<ol style="list-style-type: none"> <li>1. Verify sleep mode LED is illuminated on control board.</li> <li>2. Dispense ice for 5 seconds to reset.</li> </ol>

## SensorSAFE model troubleshooting guide

Problem	Action	SensorSAFE Board LED Status			Corrective Action
		PWR	CLN	ICE/WTR	
Does not dispense ice and/or water.	Check LEDs on the SensorSAFE control board.	OFF	OFF	OFF	Check circuit breakers and power switch. Restore power or replace defective switch.
		ON	ON	OFF	Press clean switch on lower left side of electrical enclosure to return board to normal operation.
	Place cup under drop zone (in front of lens).	ON	OFF	OFF	Troubleshoot appropriate lens/sensor and replace if required (see lens/sensor troubleshooting).
		ON	OFF	ON	Verify power on appropriate output terminal (WTR or WM) on control board and replace board if required. If board tests okay, troubleshoot appropriate dispenser component.
Dispenses ice and/or water continuously.	Check LEDs on control board.	ON	OFF	ON	Troubleshoot appropriate lens/sensor and replace if required (see lens/sensor troubleshooting).
		ON	OFF	OFF	If there is power on any output terminal (WTR or WM) on control board, replace board.

## Warranty Registration and Equipment Evaluation

Thank you for purchasing Follett® equipment. Our goal is to deliver high value products and services that earn your complete satisfaction by delivering high-value products and services backed by outstanding customer and technical support.

Please review the installation instructions thoroughly. It is important that the installation be performed to factory specifications so your equipment operates at its maximum efficiency.

Follett LLC will not be liable for any consequential damages, expenses, connecting or disconnecting charges, or any losses resulting from a defect of the machine. For full warranty details, visit our website [www.follettice.com/productwarranties](http://www.follettice.com/productwarranties).

Registering your equipments helps Follett track your equipment's service history should you need to contact us for technical support, and your feedback helps us improve our products and services. Please visit [www.follettice.com/support](http://www.follettice.com/support) to complete the Warranty Registration form.

Should you have any questions, please contact Follett's technical support group at (877) 612-5086 or (610) 252-7301 and we will be happy to assist you.

Calgon is a licensed trademark distributed by Nu-Calgon, in the United States.

Dow Corning is a registered trademark of Dow Corning Corporation in the United States and other countries.

SafeCLEAN, SaniSponge, SensorSAFE, and Symphony Plus are trademarks of Follett LLC.

Follett is a registered trademarks of Follett LLC, registered in US.



801 Church Lane • Easton, PA 18040, USA  
Toll free (877) 612-5086 • +1 (610) 252-7301  
[www.follettice.com](http://www.follettice.com)



01033729R05  
© Follett LLC 5/18