

Order parts online
www.follettice.com

Installation, Operation and Service Manual

Serial numbers below J62764

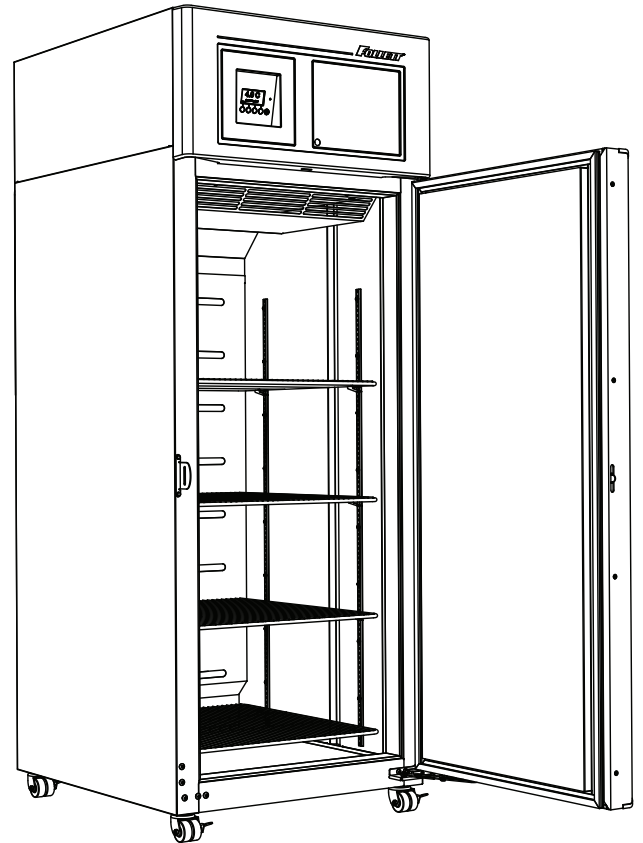
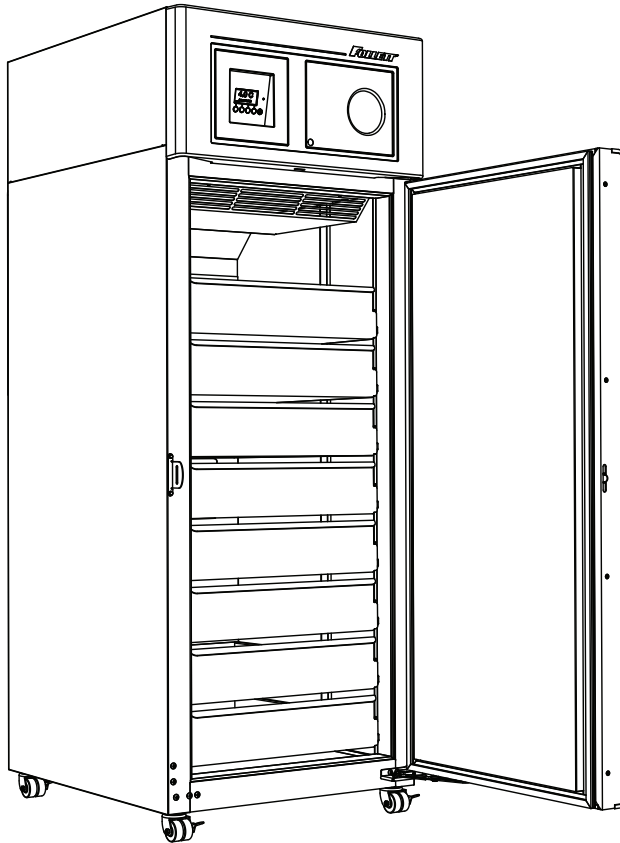

**Following installation, please forward this manual
to the appropriate operations person.**

Contents

Welcome to Follett	3	Cleaning	21
Before you begin	3	Interior cleaning	21
Specifications	3	Exterior cleaning	21
Ambients	4	Annual cleaning and inspection	22
Clearances	4	Service	23
Electrical specifications	4	Refrigeration system	23
Refrigeration specifications	4	Defrosting	23
Detail drawing	4	Controller operation	24
Installation	5	Temperature sensor readings	24
Adjust self-closing door	5	Fascia heater cycle	25
Install shelves (if equipped) and power up	5	Changing temperature set point	27
Fill product simulation bottle	6	Defrost Settings	28
Remote alarm connections (if desired)	7	Test defrost/manual defrost	30
Dry contacts	7	Compressor Data	35
RS-485 port	7	Troubleshooting	36
Third-party probe wire routing (if desired)	7	Before calling for service	36
Alarms	12	Appendix	37
Alarm muting	12	Control key functions	37
Alarm volume selection	13	Menu Navigation table	37
Alarm silence	13	Replacement parts	38
Password PIN security (default is 3843)	14	Unit cooler	38
To turn password on/off	14	Cabinet	40
To make a new password PIN	15	Facade	41
Min/max temperature logging	16	Door assembly	42
Probe calibration	16		
Method 1	16		
Method 2	18		
Chart recorder set up (if so equipped)	20		
Chart recorder calibration	20		
Changing the chart paper	20		
Replacing the pen	20		
Removing drawers	21		
Removing slides	21		

Welcome to Follett

Follett equipment enjoys a well-deserved reputation for excellent performance, long-term reliability and outstanding after-the-sale support. To ensure that this product delivers that same degree of service, we ask that you take a moment to review this manual before beginning the installation. Should you have any questions or require technical help at any point, please call our technical service group at (877) 612-5086 or +1 (610) 252-7301.

Before you begin

After uncrating and removing all packing material, inspect the equipment for concealed shipping damage. If damage is found, notify the shipper immediately and contact Follett Corporation so that we can help in the filing of a claim, if necessary.

Check your paperwork to determine which configuration you have. Follett configuration numbers are designed to provide information about the type of freezer you are receiving. Following is an explanation of the different item numbers.

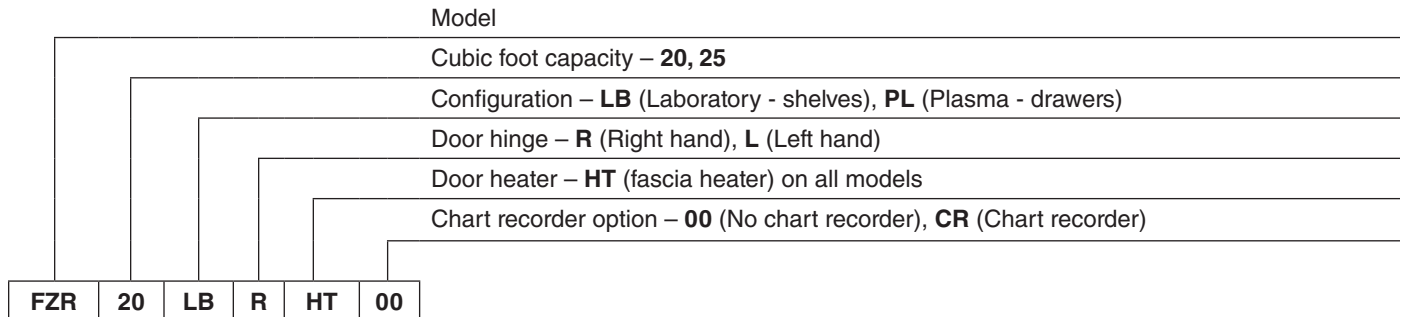

Specifications

	FZR20-LB	FZR25-LB	FZR20-PL	FZR25-PL
Capacity	19.7 cu ft (558 L)	24.6 cu ft (697 L)	19.7 cu ft (558 L)/352 plasma packs (300 ml)	24.6 cu ft (697 L)/472 plasma packs (300ml)
Storage system	(4) epoxy-coated shelves	(4) epoxy-coated shelves	(8) stainless steel drawers	(8) stainless steel drawers
Exterior width	29.75" (76cm)	29.75" (76cm)	29.75" (76cm)	29.75" (76cm)
Exterior depth	29" (74cm)	35" (89cm)	29" (74cm)	35" (89cm)
Exterior depth with handles	30.5" (78cm)	36.5" (93cm)	30.5" (78cm)	36.5" (93cm)
Exterior height with casters	79.5" (202cm)	79.5" (202cm)	79.5" (202cm)	79.5" (202cm)
Interior dimensions (W x D x H)	24" x 22.5" x 56" (61cm x 58cm x 143cm)	24" x 28.5" x 56" (61cm x 73cm x 143cm)	24" x 22.5" x 56" (61cm x 58cm x 143cm)	24" x 28.5" x 56" (61cm x 73cm x 143cm)
Crated weight	438 lb (199 kg)	467 lb (212 kg)	556 lb (252 kg)	613 lb (278 kg)
Max. heat rejection	2400 BTU/hr	2400 BTU/hr	2400 BTU/hr	2400 BTU/hr

Standard features – all models	
Door	Solid, insulated, stainless steel
Door handle	ADA-compliant, full length handle with integral lock
Interior/exterior material	Heavy-duty, corrosion resistant stainless steel
Casters	(4) dual-wheel swiveling casters with toe locks
Insulation	2.75" (7 cm) thick, CFC-free foam insulation throughout
Air circulation system	Ducted air through back plenum openings (16 - PL, 12 - LB) with front face return
Temperature probe	Stainless steel RTD (resistance temperature detectors). One at top on all models. One at bottom on PL models

Ambients

Intended for indoor use where ambient temperature does not exceed 86 F (30 C) and ambient relative humidity does not exceed 60% RH.

Clearances

To ensure proper ventilation of the refrigeration system, the following clearances are required:

- 16 inches (41cm) above the freezer
- 2 inches (5cm) behind freezer
- 9 inches (23cm) on the left side. If the ambient is <86 F (30 C), no side clearance is required.

Electrical specifications

- 120 V, 60 Hz, 1 phase
- Full load amps: 12FLA, 67 LRA compressor
- Minimum circuit ampacity: 25A with max 60 ft. (18.2 m) wire run between receptacle and breaker using minimum 12 AWG
- Minimum voltage at compressor terminals: 97 Vac when energized
- Maximum size of branch circuit overcurrent device: 20A dedicated circuit

Refrigeration specifications

Refrigerant R404a, 10.6 oz (300 g)

Detail drawing

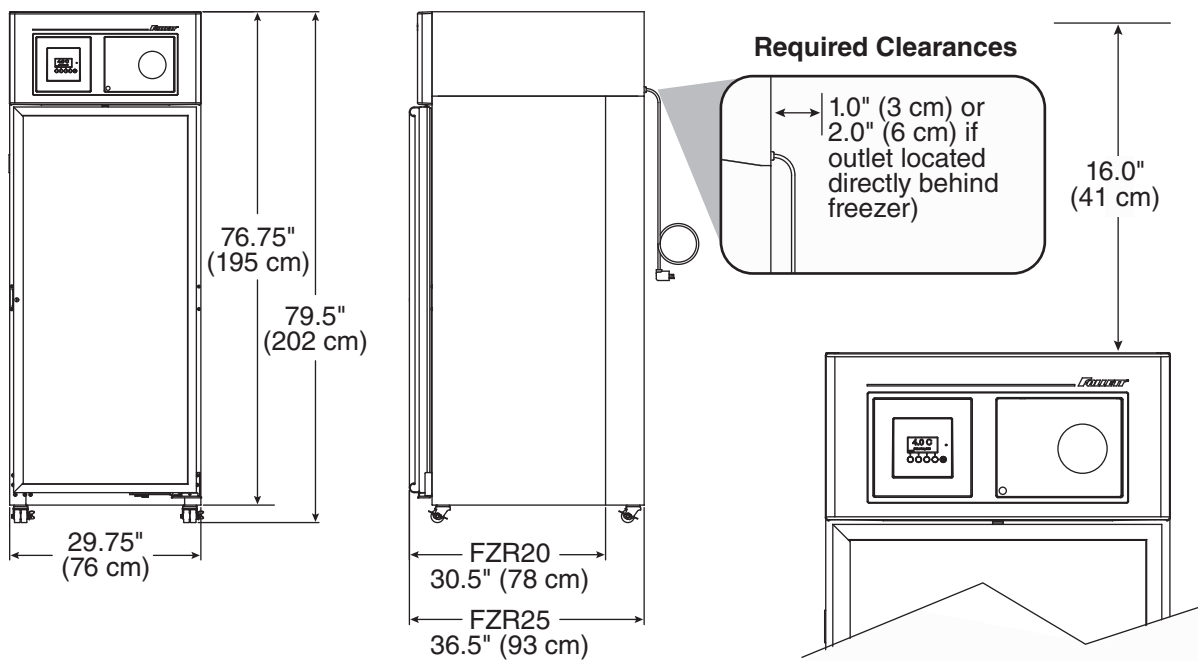

Installation

DANGER



- Do not tilt any unit further than 30° off vertical during uncrating or installation
- Refrigeration module area contains mechanical, moving parts. Keep hands and arms clear of this area at all times. If access to this area is required, power to unit must be disconnected first.

1. Remove key attached to lock catch and unlock door.
2. Remove casters from box packed inside freezer.
Note: California facilities requiring wall and floor anchors – refer to wall anchor kit instructions (#00938241) packed with seismic kit before proceeding with caster installation.
3. Unbolt freezer from pallet.
4. Rotate freezer on pallet to install casters (Fig. 1.1).
5. Install casters by hand one at a time using channel locks to tighten, until caster meets against the bottom of cabinet (Fig. 1.2).
6. Peel protective film from exterior walls of stainless cabinet.

Fig. 1

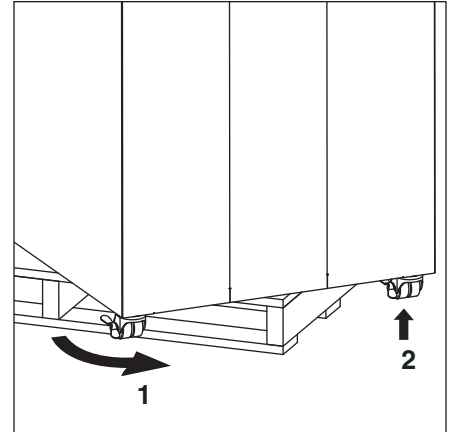

Adjust self-closing door

1. Roll freezer to desired location and lock as many casters as possible (Fig 2.1).
2. If the door appears to be sagging, remove the philips screw (Fig. 2.2) holding the Hold Open Bracket to the Hinge Bracket to gain access to the Sag Adjustment Screw (Fig. 2.3). Turn the Sag Adjustment Screw to align the door squarely with the freezer cabinet. When finished, reinstall the Hold Open Bracket.
3. Check door for closing tension and adjust if necessary. To check closing tension, open door 1" (25.4 mm) and turn screw (Fig. 2.4) counterclockwise until you achieve positive close. Then, turn another full turn counterclockwise to ensure door has sufficient closing tension.

Fig. 2

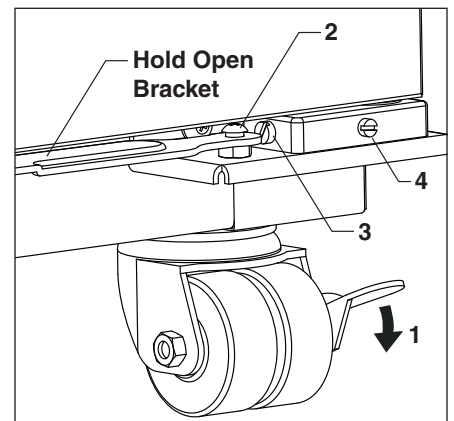

Install shelves (if equipped) and power up

1. If freezer is equipped with shelves, remove bag containing shelf supports and position them in desired locations on each pilaster and insert shelves (Fig. 3).
2. Plug freezer into a 120 V 60 Hz 20A dedicated outlet.

Fig. 3

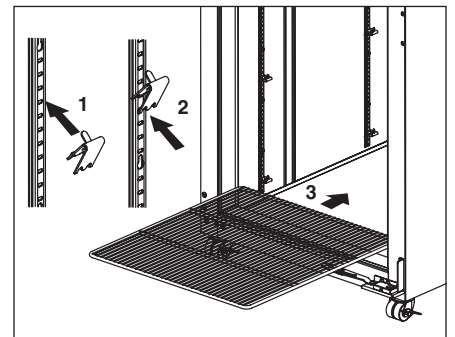

Fill product simulation bottle

1. Remove probe and cap from the top bottle and fill with solution used at your facility (e.g., 60% glycerine and 40% water) (Fig. 4). Replace cap and reinsert probe sensor.
2. If equipped with a bottom probe, perform same procedure for bottom bottle.

ATTENTION INSTALLER
It is imperative that the top probe bottle be filled with a solution that your facility uses to ensure proper operation of unit.

Fig. 4

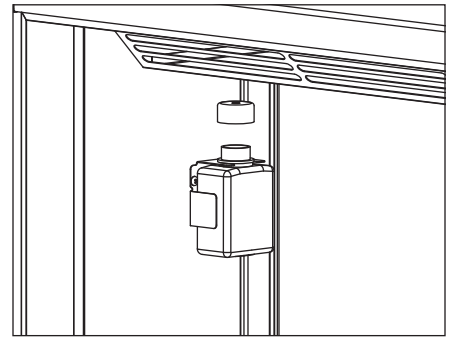
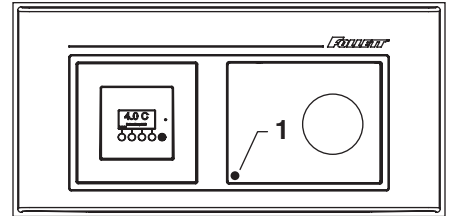
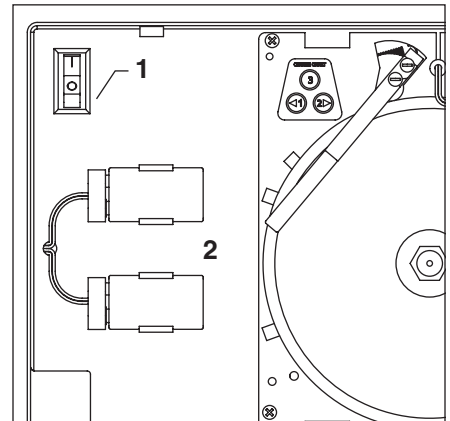

Fig. 5



3. Press lower left corner of front facade door to access power switch inside (Fig. 5.1).

Fig. 6



4. Press power switch to turn unit on (Fig. 6.1).
5. Install (2) 9 V back-up interface batteries (Fig. 6.2) and (1) 9 V chart recorder back-up battery (if equipped.)

Remote alarm connections (if desired)

Remote communication connections are located on back side of top facade (Fig. 7).

Dry contacts

- Connection to NO or NC contacts provides remote alarming capability
- No temperature data is communicated

RS-485 port

- Connection provides real-time data streaming
 - Temperature
 - Alarms
 - Refrigeration operation
- MODBUS protocol
- Uses 6 pin, 4 conductor RJ11 jack (not supplied)

Fig. 7

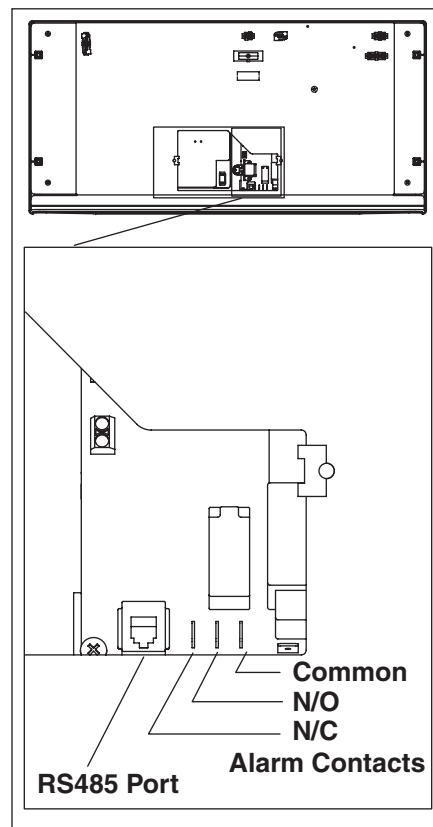

Third-party probe wire routing (if desired)

1. Use a drill or awl to prepare an opening to allow routing of the third-party probe into the cabinet at the location shown (Fig. 8).
2. Use permagum sealant to cover hole opening after probe is routed into cabinet.

Fig. 8 (top view)

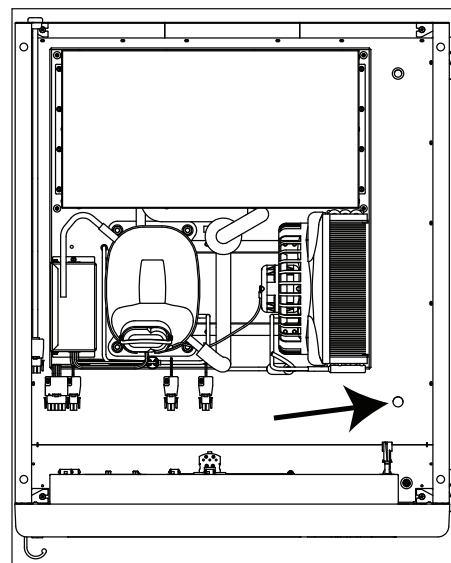

3. Remove front left and right return louver screws to uncover access port (Fig. 9).
4. Route probe wire down either side channel in cabinet.
5. Use permagum to seal around probe wire access hole.
6. Reinstall louver screws.

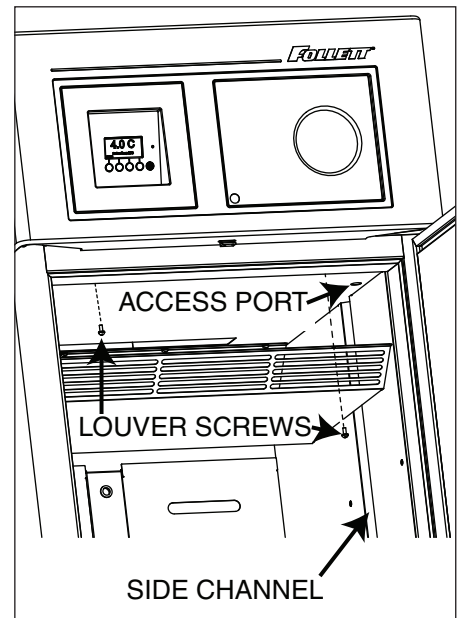

Fig. 9



Operation

Quick setup checklist

- Set time/date
- Change temperature display from factory default Celsius to Fahrenheit (if desired)
- Set high/low temperature alarms
- Select password access (if required)
- Set up chart recorder (if equipped)
- Verify solution is in bottle

 DANGER	
	<ul style="list-style-type: none"> • Do not extend all of the drawers when fully loaded to avoid the possibility of the freezer tipping forward • Refrigeration module area contains mechanical, moving parts. Keep hands and arms clear of this area at all times. If access to this area is required, power to unit must be disconnected first.

Set time & date

ATTENTION

- The time/date are not retained in the event of a power interruption or if the batteries are dead.
- Change batteries with the unit powered up. Change one battery at a time to retain time/date. Failure to follow this procedure will result in loss of time & date and will not provide accurate time and date stamping for high or low temperature alarms.

Set time and date for stamping of minimum and maximum temperatures.

1. Press **Menu** button (Fig. 10).

Fig. 10

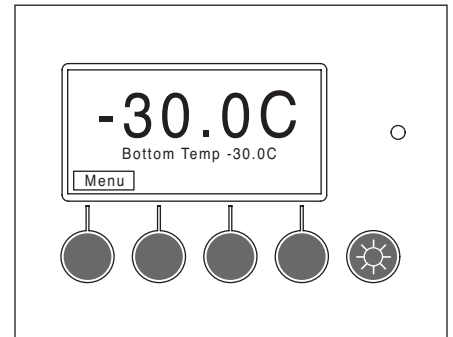

2. Use ▲/▼ to scroll and highlight **Set time/date** and press **Enter** to select (Fig. 11).

Fig. 11

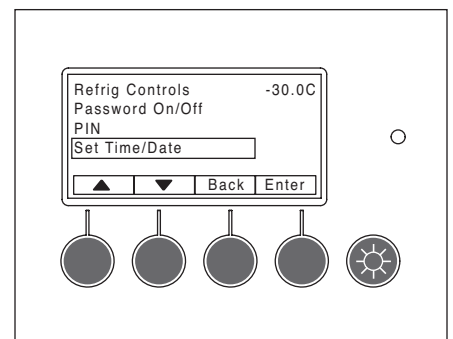

3. Adjust the year using ▲/▼ and press NEXT.
4. Adjust the month using ▲/▼ and press NEXT.
5. Adjust the day using ▲/▼ and press NEXT.
6. Adjust the hour using ▲/▼ and press NEXT. (24 HR Clock)
7. Adjust the minute using ▲/▼.
8. Press **Enter** to select values.
9. Press **Back** until the main temperature display screen is displayed.

Fig. 12

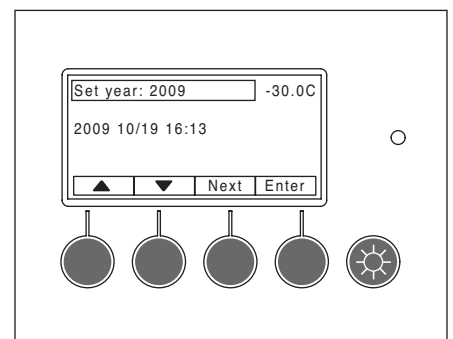

Change temperature display to show degrees Fahrenheit (if desired)

Follett has pre-set the temperature display to read in degrees Celsius. If degrees Fahrenheit display is preferred:

1. Press **Menu** button (Fig. 13).

2. Use ▲/▼ to scroll and highlight **Display Settings** and press **Enter** to select (Fig. 14).
3. Use ▲/▼ to scroll and highlight **Degrees F/C** and press **Enter** to select.
4. Use ▲/▼ to scroll and highlight **F** and press **Enter** to select.
5. Press **Back** button until the main temperature display screen is displayed. Temperature is displayed in degrees F.

High and low alarm setup

The high alarm is set to a default of 40 C (104 F) from the factory. This default setting is used so that the alarm will not sound while the unit is pulling down to temperature. The low alarm default setting is -40.0 C (-40.0 F).

After the unit has been installed and the system has stabilized (approximately 90 min.), the high and low alarm set points should be adjusted to desired settings.

1. Press **Menu** button (Fig. 15).

2. **Alarm Settings** will be highlighted. Press **Enter** to select (Fig. 16).

Fig. 13

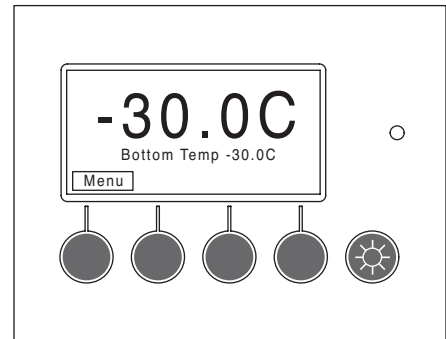

Fig. 14

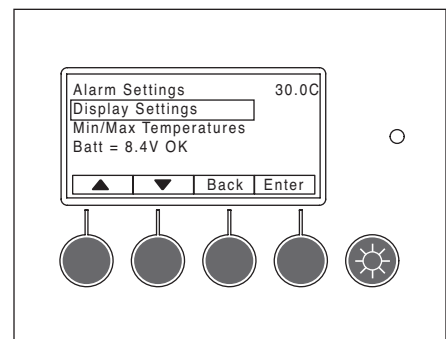

Fig. 15

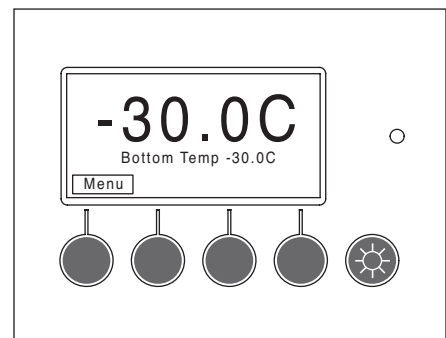
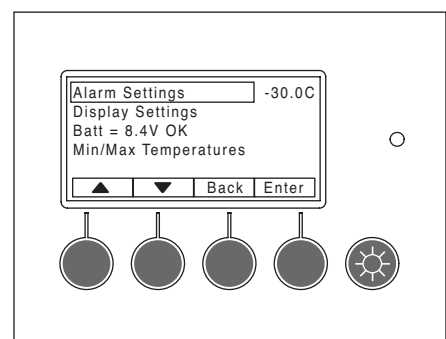
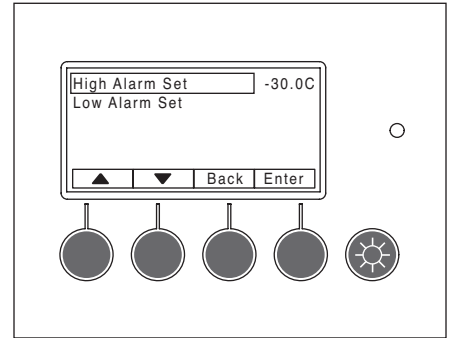

Fig. 16



- Use ▲/▼ to scroll and highlight **High Alarm Set** and press **Enter** to select (Fig. 17).

Fig. 17



- Use ▲/▼ to change set point and press Enter to accept (Fig. 18).

Fig. 18

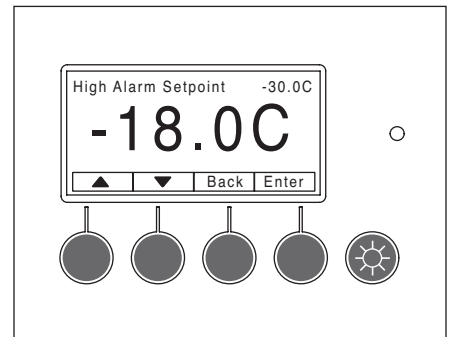

- Use ▲/▼ to scroll and highlight **Low Alarm Set** and press **Enter** to select (Fig. 19).

Fig. 19

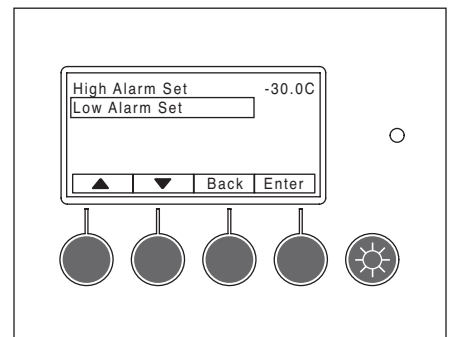

- Use ▲/▼ to change set point and press Enter to accept (Fig. 20).
- Press **Back** until the main temperature display screen is displayed.

Fig. 20

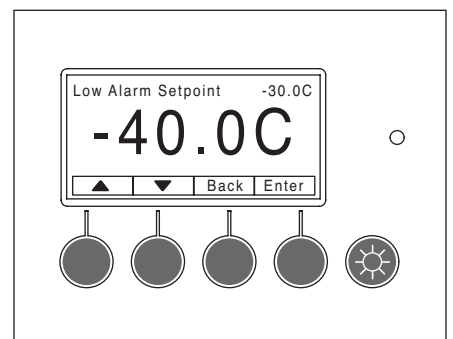

Alarms

The freezer has several alarms that will sound an audible and visual alarm. Alarm type is shown on the top line of the alarm display and multiple alarms will show progressively on the display. A red LED, to the right of the display, accompanies all alarms.

All active alarms are conveyed to remote alarm relays. Remote alarm relay provides a choice of either a normally closed (NC) or normally open (NO) contact. It is recommended for use at 24 V 1A (relay is rated for 250 V 10A).

Alarm displayed	Conditions
Temp Alarm	Only top product temperature probe activates this alarm. Bottom product temperature probe, if installed, is for display reference only.
Top Probe Error (RTD1)	Activates with loss of signal from top probe (open or short circuit).
Bottom Probe Error (RTD2)	Activates with loss of signal from bottom probe (open or short circuit).
Door Ajar Alarm	Activates with door open longer than 1 minute.
AC Power Alarm	Activates after 2 min delay with loss of AC power. Display backlight will turn off to conserve battery life, but pressing any button will brighten display for 30 seconds.
Low Battery Alarms	Display activates when (2) 9V controller back-up batteries decrease to 7.5 V (maximum 4 hr back-up time remaining.) This alarm will audibly chirp every 5 minutes. Chart recorder – LED flashes green. All batteries should be changed at same time. Replace batteries one at a time with AC power on to keep correct time/date.
Evap Probe Error (NTC1)	Activates with loss of signal from refrigeration control evaporator probe (open or short circuit). Freezer goes into a fixed on/off cycle until corrected. Default settings are 6 minutes compressor on time and 5 minutes compressor off time. Cycle on time and off time are adjustable in faulty probe cycle sub-menu of refrigeration controls menu.
Defr Probe Error (NTC2)	Activates with loss of signal from NTC2 defrost probe (open or short circuit).

Alarm muting

All audible alarms can be muted for up to 60 minutes in 5 minute increments by pressing the **MUTE** button. The desired mute period will display, and count down, in the window adjacent the MUTE label (Fig. 21).

Fig. 21

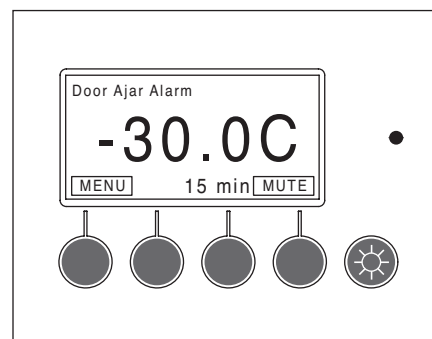

Alarm volume selection

Factory default setting is “high”. To change volume of the alarm:

1. Press **Menu** button (Fig. 22).

Fig. 22

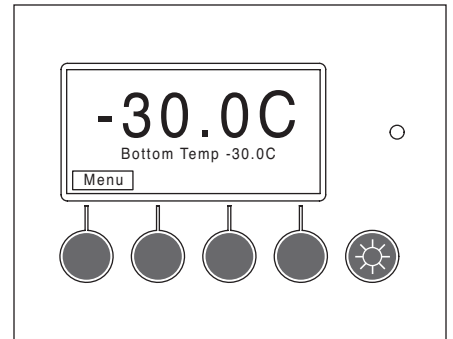

2. Use ▲/▼ to scroll and highlight **Set Alarm Volume** and press **Enter** to select (Fig. 23).

Fig. 23

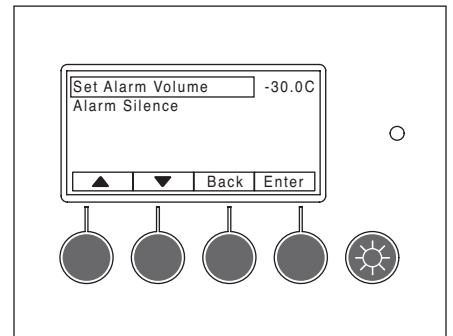

3. Use ▲/▼ to select the volume (high/medium/low) and press **Enter** to select (Fig. 24).
4. Press **Back** until the main temperature display screen is displayed.

Fig. 24

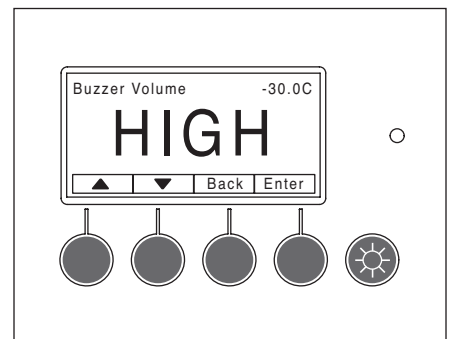

Alarm silence

Audible alarming can be turned off through the menu interface:

1. Press **Menu** button (Fig. 25).

Fig. 25

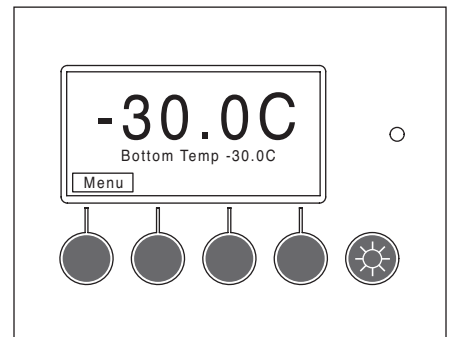

- Use ▲/▼ to scroll and highlight **Alarm Silence** and press **Enter** to select (Fig. 26).

Fig. 26

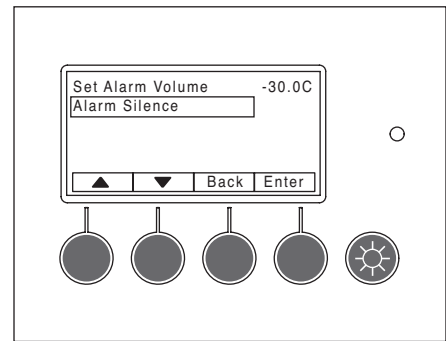

- Use ▲/▼ to select **ON** or **OFF** and press **Enter** to select (Fig. 27).
- Press **Back** until main temperature display screen is displayed.

Fig. 27

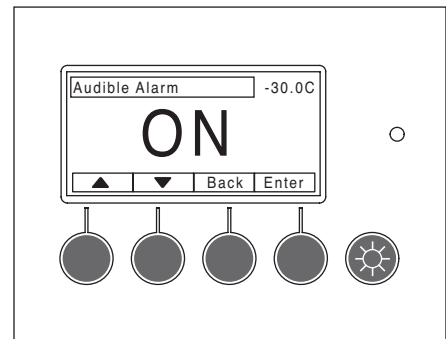

Fig. 28

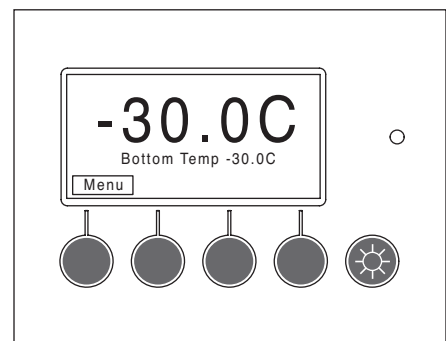
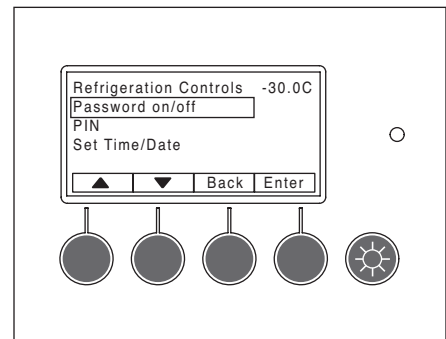

Fig. 29



Password PIN security (default is 3843)

If desired, access to the user selectable features and settings can be controlled by a password PIN. The freezer ships with the password option turned off. The default password PIN, if the password is turned on, is 3843. This password pin number will always work.

To turn password on/off

- Press **Menu** button (Fig. 28).
- Use ▲/▼ to scroll and highlight **Password on/off** option and press **Enter** to select (Fig. 29).

- Use ▲/▼ to choose **ON** or **OFF** and press **Enter** to select (Fig. 30).
- Press **Back** until the main temperature display screen is displayed.

Fig. 30

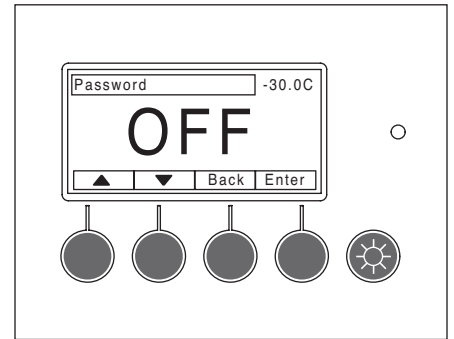
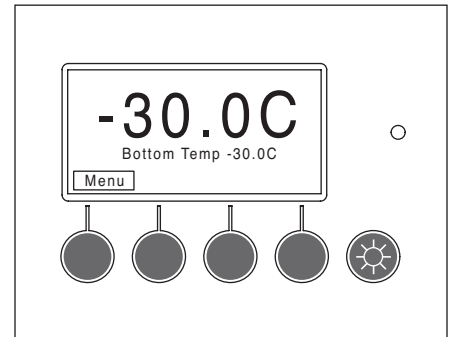

Fig. 31



To make a new password PIN

- Press **Menu** button (Fig. 31).

Fig. 32

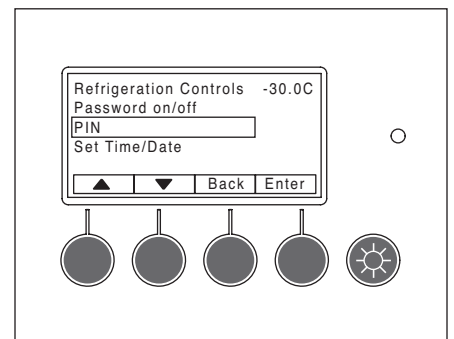

- Use ▲/▼ to scroll and highlight **PIN** and press **Enter** to select (Fig. 32).

Fig. 33

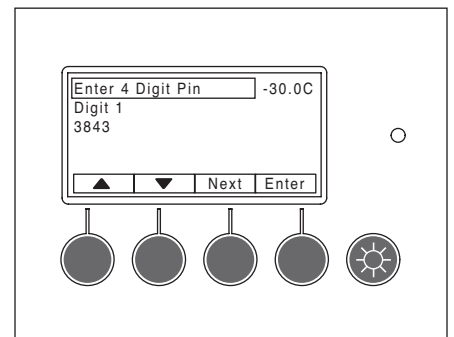

- Use ▲/▼ to select the first number of the 4 digit pin. Use the **Next** button to move to the next digit, adjust with ▲/▼ and repeat for the last 2 digits. Press **Enter** to select (Fig. 33).
- Press **Back** until the main temperature display screen is displayed.

Min/max temperature logging

The controller retains maximum and minimum temperatures since last reset and provides a date and time stamp of when they occurred.

1. Press **Menu** button (Fig. 34).

Fig. 34

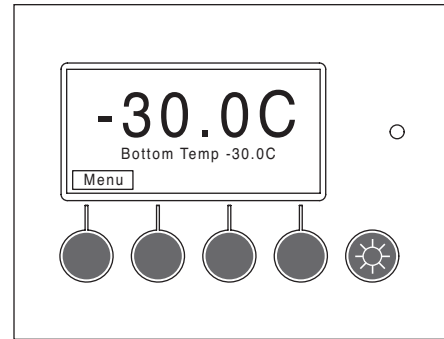

2. Use ▲/▼ to scroll and highlight **Min/Max Temperatures** and press **Enter** to select (Fig. 35).

Fig. 35

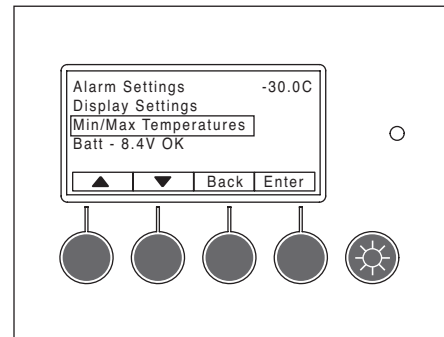

3. Use ▲/▼ to select the min or max logged temperature (Fig. 36). Press **Enter** to reset log.
4. Press **Back** until the main temperature display screen is displayed.

Fig. 36

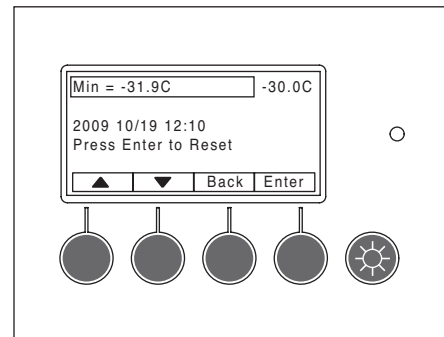

Probe calibration

Follett freezer probes are calibrated to a known standard prior to leaving the factory. Recalibration can be easily accomplished at any time, if desired:

Method 1

1. Using a separate temperature sensor and readout with an accuracy better than ± 0.3 C (0.5 F) at -30 C (-22 F) (a NIST traceable calibrated probe and readout is preferred), place probe in same solution as RTDI top product probe.
2. Close door.
3. Press Menu button (Fig. 37).

Fig. 37

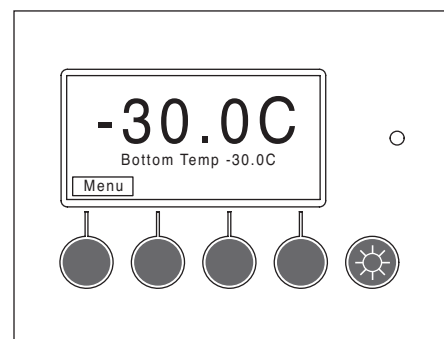

- Use ▲/▼ to scroll and highlight **Refrigeration Controls** (Fig. 38).

Fig. 38

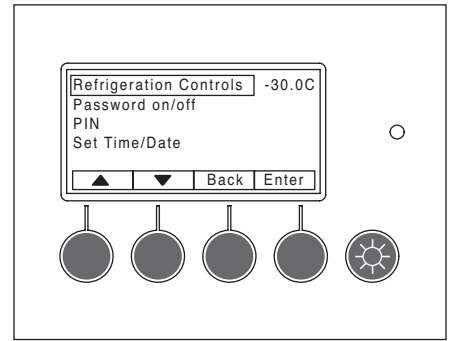

- Press and hold **Enter** and **Down (▼)** button for 3 seconds, until new submenu appears with **Calibration** highlighted (Fig. 39).
- Press the **Enter** button.

Fig. 39

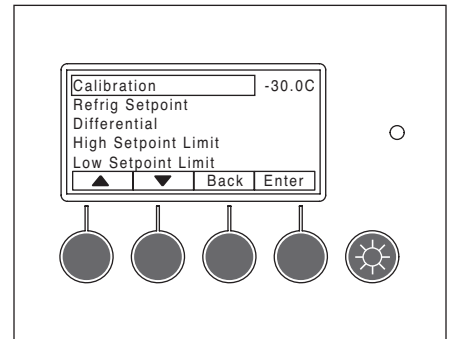

- With **Cal Top Probe** highlighted, press **Enter** to select (Fig. 40).

Fig. 40

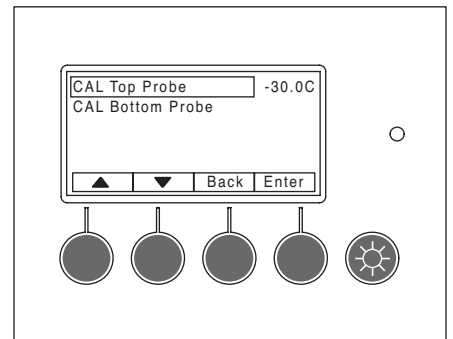

- After the separate temperature sensor and readout stabilizes, adjust the Cal temperature using ▲/▼ so that it matches the reading from the separate sensor and readout.
- Press **Enter** button calibrating the top probe to the separate temperature sensor and readout reading (Fig. 41). Repeat procedure if calibrating the bottom probe.
- Press **Back** until main temperature display screen is displayed.

Fig. 41

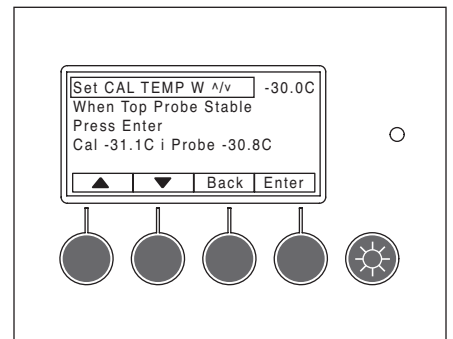

ATTENTION

- Bottom temperature probe is only standard on plasma models
- If unit has the chart recorder option, refer to “Chart recorder calibration” on page 20.

Method 2

1. Remove upper temperature probe from probe bottle and completely submerge into an ice bath.
Note: Ice bath should be densely compacted ice (flake, crushed, nugget, or cracked) and a little water.
2. Press **Menu** button (Fig. 42).

Fig. 42

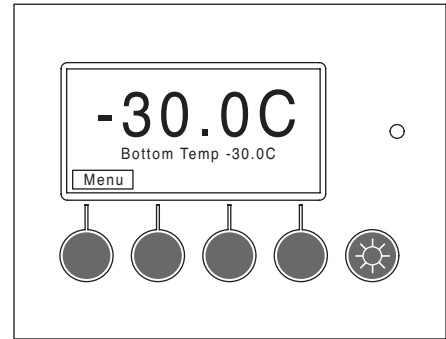

3. Use ▲/▼ to scroll and highlight **Refrigeration Controls**, press and hold **Enter** and ▼ together for 3 seconds (Fig. 43).

Fig. 43

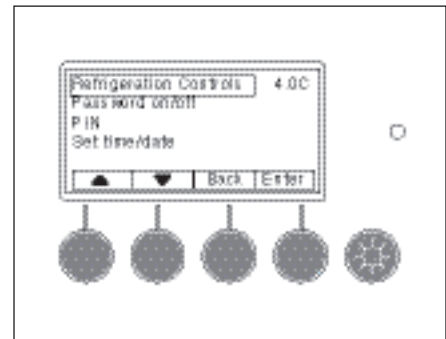

4. **Calibration** should be highlighted, press **Enter** to select (Fig. 44).

Fig. 44

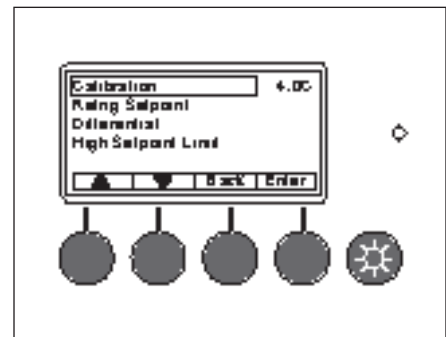

5. **Cal Top Probe** should be highlighted, press **Enter** to select (Fig. 45).

Fig. 45

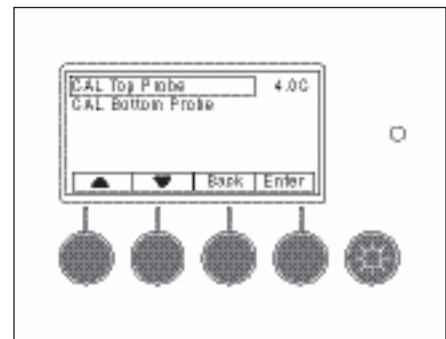

6. Use ▲/▼ to scroll and highlight **Refrigeration Controls** (Fig. 46).

Fig. 46

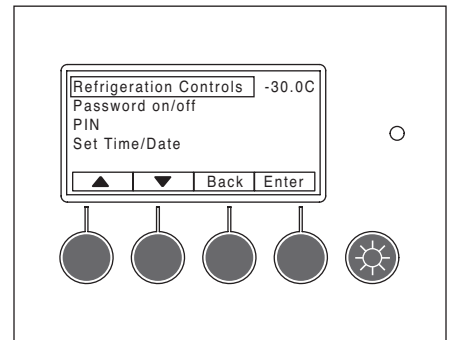

7. Press and hold **Enter** and **Down** (▼) button for 3 seconds, until new submenu appears with **Calibration** highlighted (Fig. 47).

8. Press the **Enter** button.

Fig. 47

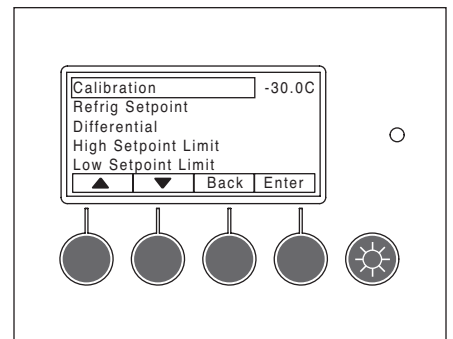

9. With **Cal Top Probe** highlighted, press **Enter** to select (Fig. 48).

Fig. 48

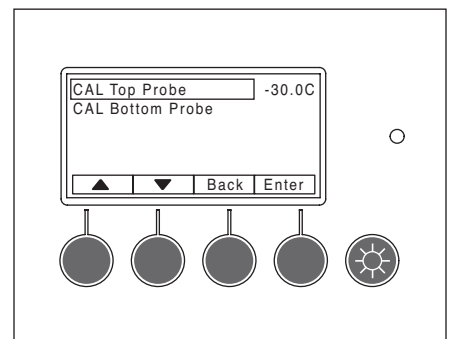

10. When probe temp stabilizes press **Enter** button calibrating it to 0.0 C (32 F) (Fig. 49). Wait one minute and press **Enter** button again to confirm calibration.

11. Remove probe from ice bath and return to solution-filled probe bottle.

12. Press **Back** until main temperature display screen is displayed.

13. Repeat steps for bottom probe, if equipped.

Fig. 49

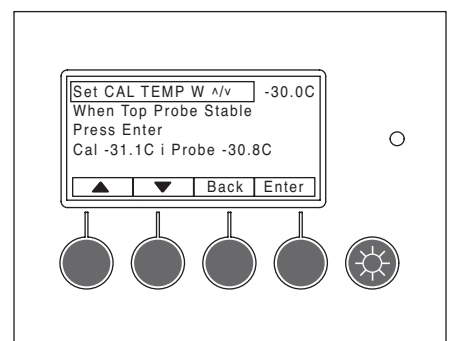

ATTENTION
<ul style="list-style-type: none"> • Bottom temperature probe is only standard on plasma models • If unit has the chart recorder option, refer to “Chart recorder calibration” on page 19.

Chart recorder set up (if so equipped)

The chart recorder is mounted in the front right of the facade behind the door (Fig. 42). A package of 50 charts that record in C is included with your freezer. If you have changed your display to show temperatures in F, you will need different charts. Please call Follett at (877) 612-5086 or +1 (610) 523-9361 to order part number 00980888.

The chart recorder is powered by the controller and has its own battery back up. An LED provides battery status info: Steady green = battery okay, Flashing green = low battery or no power to the controller.

Chart recorder calibration

If desired, calibration should be done at the same time as probe calibration (**page 17**) by pressing either the left or right arrow keys until it corresponds with the calibrated product display temperature.

1. Press **Left #1** or **Right #2** arrow button (Fig. 40) for 5 seconds until pen begins to move.
2. Continue to press **#1** or **#2** button to move pen to record same temperature as probe.

Changing the chart paper

1. Press and hold **#3** button until pen begins to move off chart.
2. Once the pen moves completely off chart, unscrew knob (counter-clockwise) at center of chart.
3. Remove old chart and place new chart in position so that correct time coincides with time line groove on recorder.
4. Reinstall knob.
5. Press and hold **#3** button for approximately (1) one second until pen begins to move back onto chart.
6. Make sure pen is marking paper. If not, carefully adjust arm so that pen makes contact with paper.

Replacing the pen

1. To replace pen, press and hold the **#3** button until pen starts to move off chart.
2. Once pen has moved completely off chart, carefully lift pen up and unsnap the “U” clip part to remove pen from metal pen arm.
3. Position new pen on metal pen arm and snap “U” clip underneath pen around arm to secure.
4. Press and hold **#3** button for approximately (1) second until pen begins to move back onto chart.
5. Make sure pen is marking. If not, carefully adjust arm so that pen makes contact with paper.

Fig. 50

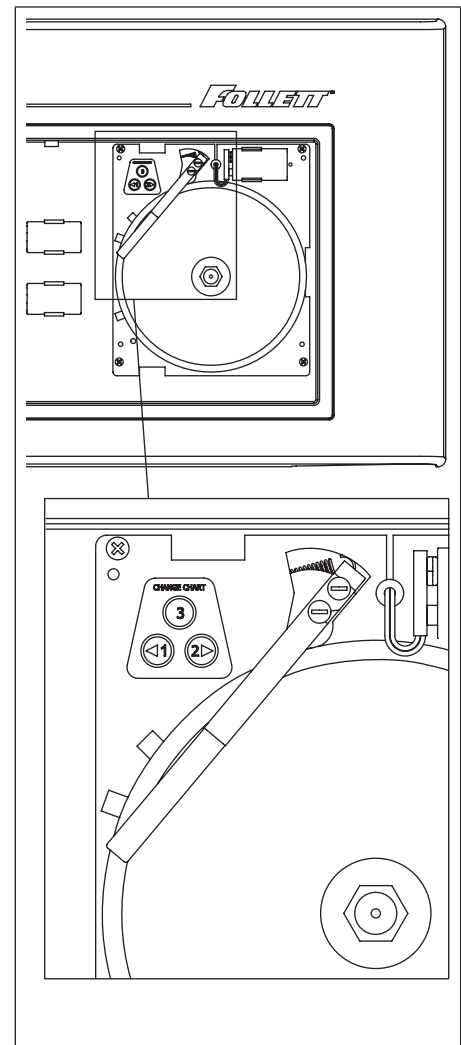

Removing drawers

1. Pull drawer forward to stop (Fig. 51.1).
2. Lift drawer front to free front rollers from slides (Fig. 51.2).
3. Still lifted, pull drawer forward to free back rollers from slides.

Removing slides

1. Push slides all the way back.
2. Swing bottom of slide away from freezer wall and lift slide off rollers.

Cleaning

Use non-chlorine-based cleaners. Cleaners containing chlorine can cause staining and pitting of the stainless steel.

Disconnect power to unit by turning the power switch off, located on the upper front facade panel, and removing the power cord from the receptacle.

Interior cleaning

Using a sponge or soft cloth, clean unit with a non-abrasive, non-chlorinated, all-purpose detergent. Note: The left and right air plenums should be removed to clean them, as well as behind them (Fig. 52, 53). In addition the shelves, drawers and slides should be cleaned as well. Allow unit to dry thoroughly prior to turning on.

Exterior cleaning

Wipe stainless steel exterior with a soft cloth in the direction of grain as needed. Stainless steel polish may be used to enhance the finish of the unit. The glass door and exterior parts may be cleaned with a soft cloth, window cleaner or other non-abrasive cleaner.

Fig. 51

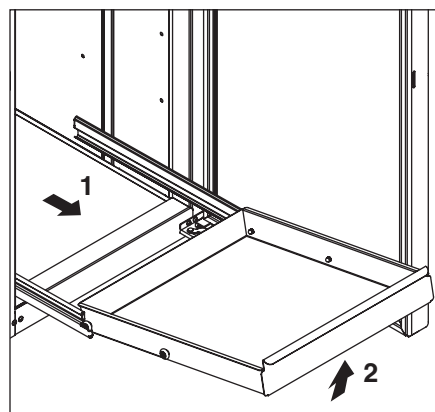

Fig. 52

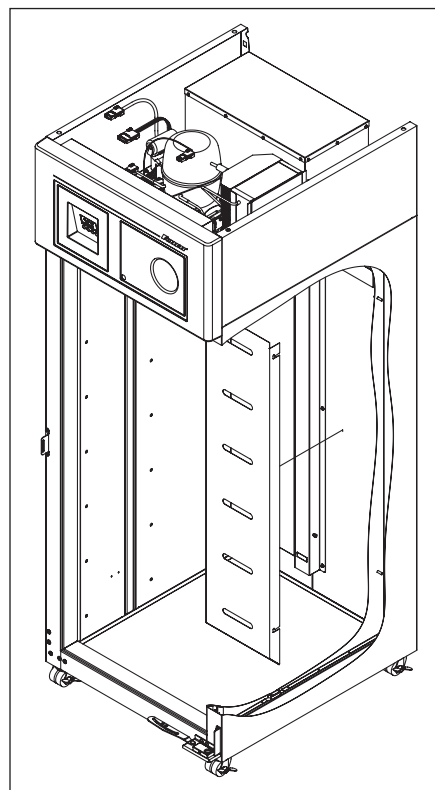
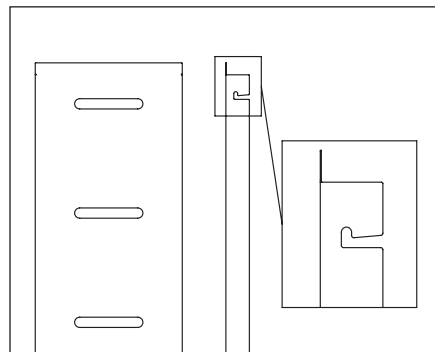

Fig. 53



Annual cleaning and inspection

Removal of dust and other particulates from air intake areas and the condenser is important for proper operation. Environments with large amounts of dust may require more frequent cleaning.

1. Disconnect power to unit by turning power switch off (located on upper front facade panel) and removing power cord from receptacle.
2. The condenser can be accessed from top for cleaning. The side panel in front of condenser may be completely removed for easier cleaning by disconnecting facade and removing upper side panel. See “Facade removal” on page 30 for facade removal instructions.
3. Inspect condensate pan for any debris or obstruction in condensate pan (Fig. 54.1).
4. Use a vacuum cleaner with brush attachment to clean condenser, compressor and related parts.
5. Use a flashlight to look in louvers on the top return air panel (Fig. 55.1).
6. If there is significant ice accumulation in the return, defrost completely.
7. Door maintenance: Place a dab of white lithium grease on top of hold open arm and keeper on lower hinge assembly of door (Fig. 56.1).

Fig. 54

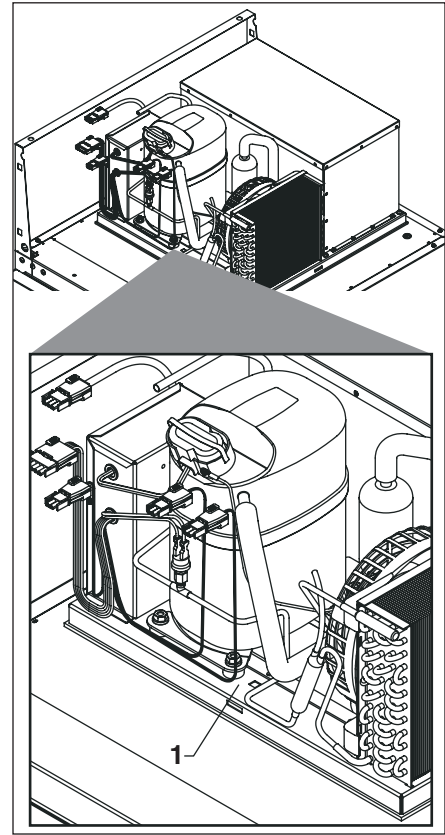

Fig. 55

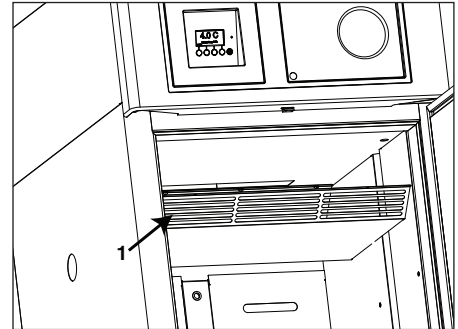
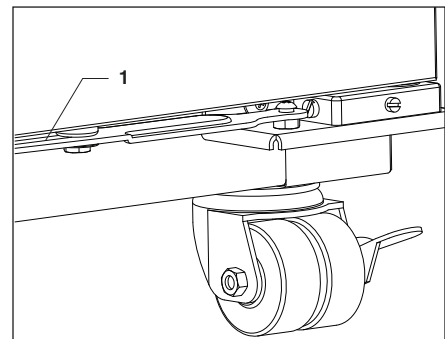

Fig. 56



Service

The temperature controller and evaporator probe (NTC1) indicate when the refrigeration system is required to turn on and off.

Plasma (PL) models are factory set with a -31.0 C (-23 F) set point. Lab (LB) models are factory set with a -24 C (-11.2 F) set point.

The refrigeration system removes heat from the cabinet interior and rejects it to the surrounding room air. When the evaporator probe temperature reaches -30.0 C (-22 F) on PL models, or -23 C (-9.4 F) on LB models, the controller turns the refrigeration system on. The normally open controller contacts close and energize the slave relay energizing the condenser fan motor and compressor. The compressor uses a potential relay and a starting capacitor and run capacitor to start the compressor motor.

When the evaporator probe temperature reaches -32.0 C (-25.6 F) on PL models or -25 C (-13 F) on LB models, the controller turns the refrigeration system off. The controller contacts reopen, which de-energizes the slave relay and de-energizes the condenser fan motor and the compressor. The evaporator fan motor runs continuously when the door is closed and the unit is not in defrost.

Refrigeration system

The FZR20/25 series refrigeration system is designed to give many years of trouble-free service. Except for routine cleaning of the air-cooled condenser and related parts, the refrigeration system requires no service or maintenance. The system uses a thermostatic expansion valve (TXV) metering device and is critically charged. Access fittings are not provided. Temporary piercing valves are required to work on the refrigeration system. Follett recommends that if hoses are ever connected to the refrigeration system for service, the refrigerant should be recovered, permanent access valves should be installed and the system evacuated, and recharged by weighing in the correct refrigerant charge (10.6 oz. (300g) R404a).

Note: Do not charge the system by pressures.

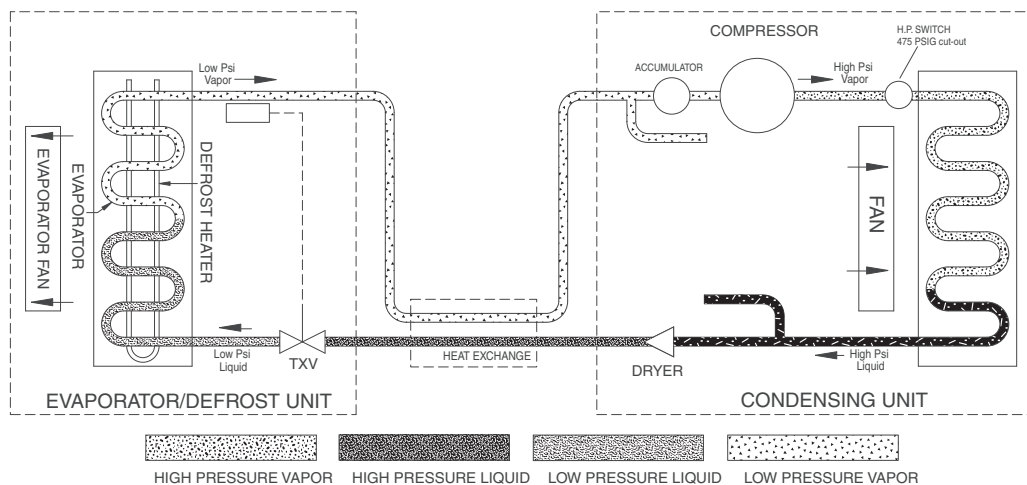

Defrosting

The FZR20/25 series upright freezers control frost accumulation on the evaporator through automatic timed defrost cycles. The evaporator defrosts automatically every 4 hours. The evaporator face mount heater, drain pan heater, and condensate drain line heater energize and any accumulated ice on the evaporator and evaporator drain pan melts and drains out the drain line to the condensate pan located under the compressor. Defrosting will display on the main screen above the product temperature button. Defrost terminates when either 30 minutes has elapsed or the evaporator temperature reading from the defrost probe (NTC2) reaches 5.0 C.

After defrost terminates, there is a 2 minute drip time delay to allow excess condensation to drip off the evaporator coil before the compressor and condenser fan motor cycle on. The evaporator fan motor is off during defrost and is delayed an additional 4 minutes for a total delay of 6 minutes after defrost terminates before cycling on. The heat from the compressor, condenser and hot gas discharge line along with the airflow from the condenser fan evaporates any condensate in the drain pan as well as providing preliminary cooling of the high pressure vapor prior to entering the condenser. As a safety feature, two temperature safety switches are mounted on the inside of the evaporator enclosure. One is mounted on the back of the evaporator and the other on the bottom of the evaporator drain pan. These switches automatically turn off either the evaporator defrost heater or evaporator drain pan heater if the temperature exceeds 27 C (80 F), regardless of controller operation.

Note: If defrost terminates on time, it will display “Defrost Timed Out” on the main menu screen. This may indicate that the evaporator has not completely defrosted.

Controller operation

ATTENTION
BEFORE MAKING ANY CHANGES TO FACTORY-DEFAULT REFRIGERATION SETTINGS, CONTACT FACTORY.

The controller displays product temperatures in degrees C or F (C is factory default) to 1 decimal point.

The controller is pre-programmed with a -31.0 C (-23.8 F) set point on PL models and a -24.0 C (-11.2 F) set point on LB models. This provides a compressor cut-in at -30.0 C (-22.2 F) on PL models and -23.0 C (-9.4 F) on LB models. The compressor will cut-out at -32 C (-25.6 F) on PL models and -25 C (-13 F) on LB models. This will correlate to a product temperature of approximately -30.0 C (-22.2 F) on PL models and -23.0 C (-9.4 F) on LB models.

All set points have a 1 C (1.8 F) differential.

Product temperature will be displayed on the digital temperature display and chart recorder (if equipped).

Temperature sensor readings

To view temp sensor probe readings:

1. Press **Menu** button (Fig. 57).

Fig. 57

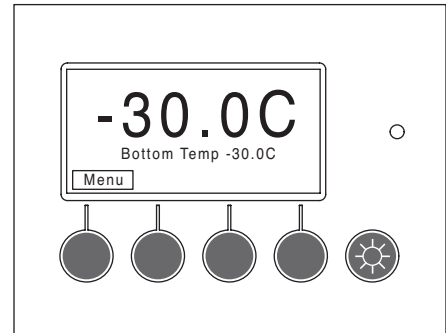

2. Use ▲/▼ to scroll and highlight **Refrigeration Controls** (Fig. 58).

Fig. 58

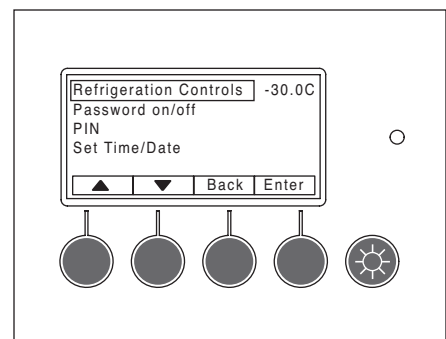

3. Press and hold **Enter** and ▼ together for 3 seconds (Fig. 59).

Fig. 59

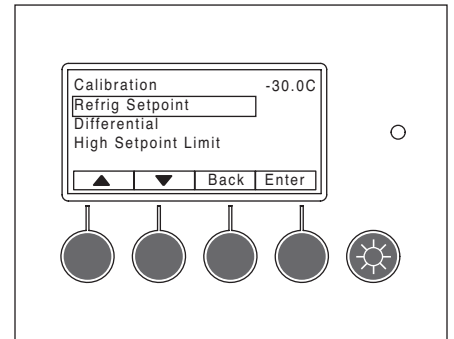

4. Use ▲/▼ to scroll and highlight **Temp sensors** and press **Enter** to select (Fig. 60).

Fig. 60

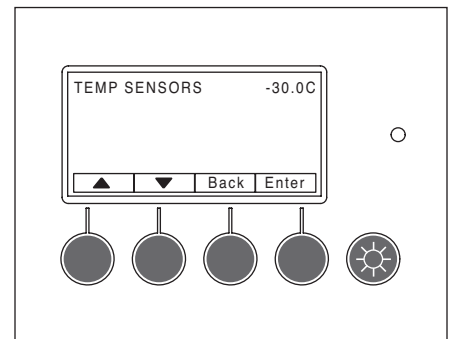

5. The following will be displayed (Fig. 61).
 - RTD1 = Top probe sensor reading from probe mounted in top bottle submerged in solution
 - RTD2 = Bottom probe sensor reading from probe mounted in bottom bottle submerged in solution (if equipped, otherwise displays default 25 C (77 F))
 - NTC1 = Evaporator probe
 - NTC2 = Defrost probe embedded in evaporator coil
6. Press **Back** until main temperature display screen is displayed.

Fig. 61

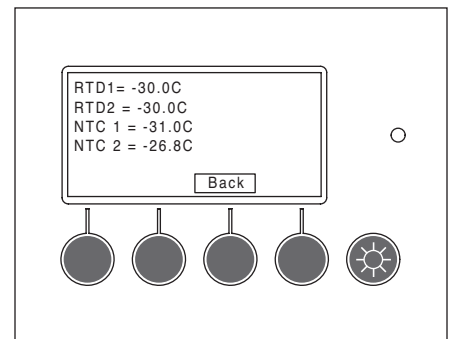

Fascia heater cycle

Factory default for the fascia heater cycle is set to 75%, based on a 20 minute cycle (e.g. 75% = 5 minutes off, 15 minutes on).

1. Press **Menu** button (Fig. 62).

Fig. 62

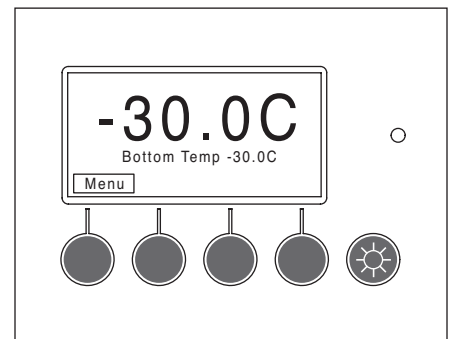

- Use ▲/▼ to scroll and highlight **Refrigeration Controls** (Fig. 63).

Fig. 63

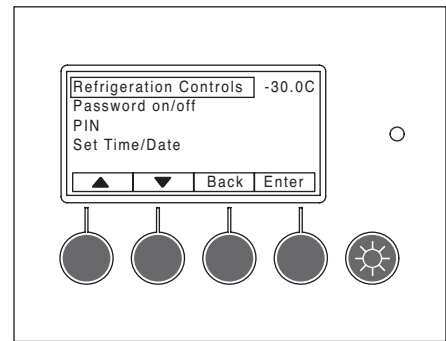

- Press and hold **Enter** and ▼ together for 3 seconds (Fig. 64).

Fig. 64

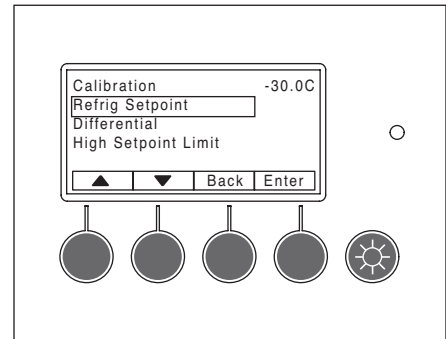

- Use ▲/▼ to scroll and highlight **Door Heater Cycle** and press **Enter** to select (Fig. 65).

Fig. 65

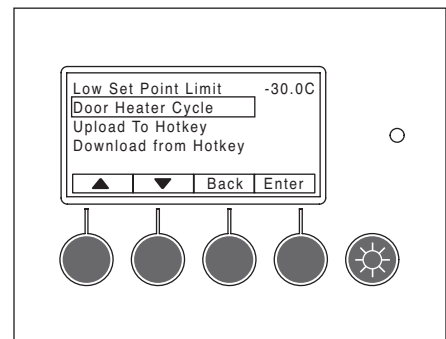

- Heater ON cycle is shown as a percentage of 20 minute cycle (Fig. 66).
- Use ▲/▼ to adjust heater ON cycle percentage and press **Enter** to select. Do not go lower than default setting of 75%.
- Press **Back** until the main temperature display screen is displayed.

Fig. 66

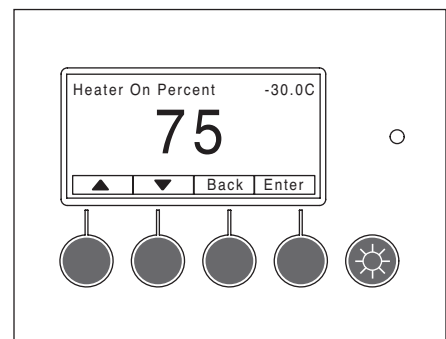

Changing temperature set point

ATTENTION
BEFORE MAKING ANY CHANGES TO FACTORY-DEFAULT REFRIGERATION SETTINGS, CONTACT FACTORY. FACTORY DEFAULT IS IN DEGREES C. IF USER HAS CHANGED DISPLAY TO SHOW TEMPERATURE IN DEGREES F, ALL OTHER TEMPERATURES WILL DISPLAY IN DEGREES F.

The temperature control system is preset by the factory to provide a product temperature of approximately -30.0 C (-22.0 F) on PL models and approximately -23.0 C (-9.4 F) on LB models. If desired, the evaporator set point temperature can be changed to achieve a different product temperature. The set point should be 1.0 C (1.8 F) degrees colder than the desired product temperature. For example, if you want the product temperature to be -28 C (-18.4 F), you would change the Control set point to -29 C (-20.2 F). The factory default setting for the differential 1.0 C (1.8 F) should not be changed.

Changing the temperature set point:

1. Press **Menu** button (Fig. 67).
2. Use ▲/▼ to scroll and highlight **Refrigeration Controls** (Fig. 68).
3. Press and hold **Enter** and then ▼ together for 3 seconds.
4. When the submenu displays, press ▼ to highlight **Refrig Setpoint**, press **Enter** to select (Fig. 69).
5. Use ▲/▼ to increase or decrease the set point and press **Enter** to select (Fig. 70).
6. Press **Back** until the main temperature display screen is displayed.

Fig. 67

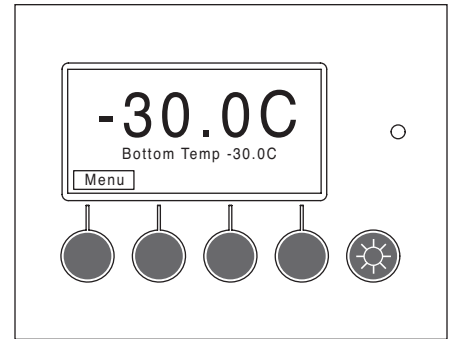

Fig. 68

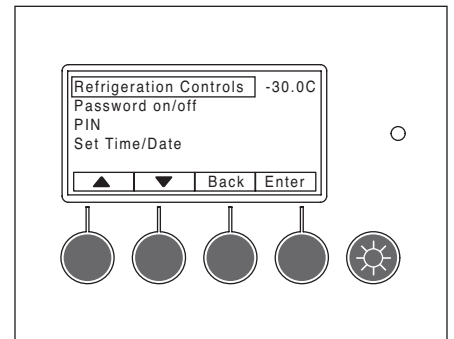

Fig. 69

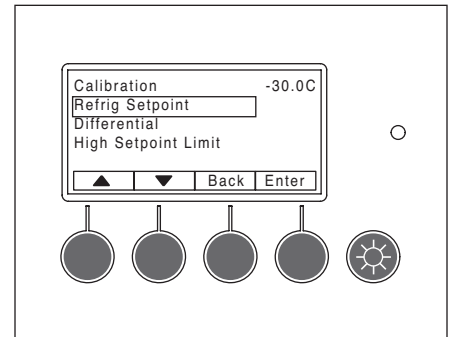
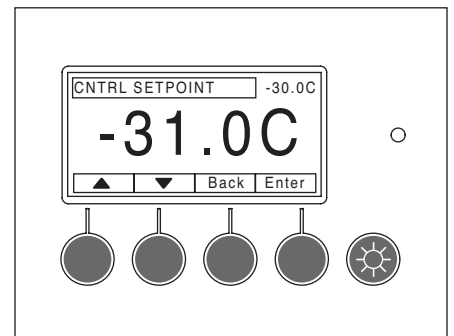

Fig. 70



Defrost Settings

1. Press Menu button.
2. Use ▲/▼ to scroll and highlight **Refrigeration Controls** (Fig. 71).

Fig. 71

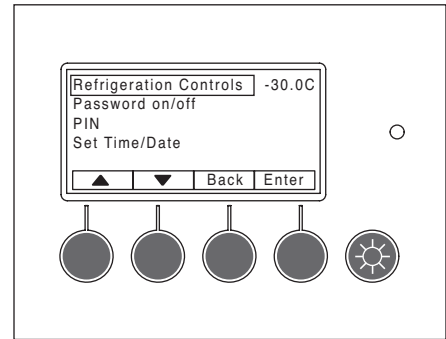

3. Press and hold **Enter** and **Down** (▼) button for 3 seconds, until new submenu appears with **Calibration** highlighted (Fig. 72).

Fig. 72

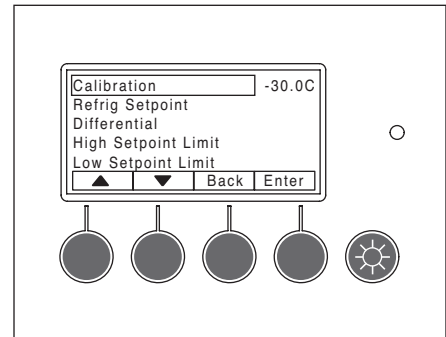

4. Use ▲/▼ to scroll and highlight **Defrost** (Fig. 73) and press **Enter** to select.

Fig. 73

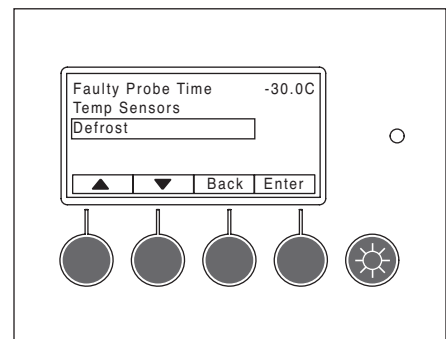

5. **Defrost Interval** will be highlighted (Fig. 74), press **Enter** to view. The defrost interval is factory-set to every 4 hours - *consult Technical Service prior to changing.*
6. Press **Back** to return to the **Defrost Interval** screen.

Fig. 74

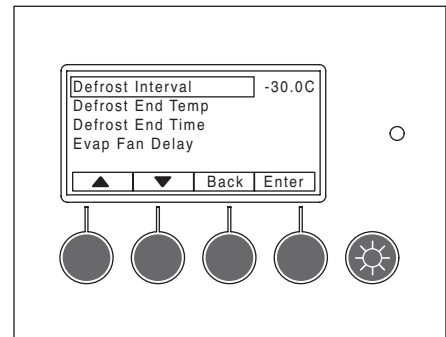

7. Use ▲/▼ to scroll and highlight **Defrost End Temp** (Fig. 75), press **Enter** to view.
The defrost will terminate at 5.0 C (41.0 F) evap temperature - *consult Technical Service prior to changing.*
8. Press **Back** to return to the **Defrost End Temp** screen.

Fig. 75

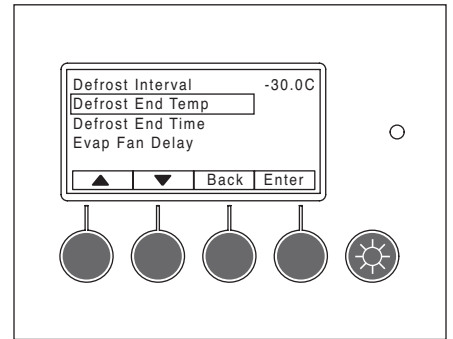

9. Use ▲/▼ to scroll and highlight **Defrost End Time** (Fig. 76), press **Enter** to view.
The defrost will terminate after 30 minutes if evap temperature does not reach termination temp of 5.0 C (41.0 F) - *consult Technical Service prior to changing.*
10. Press **Back** to return to the **Defrost End Time** screen.

Fig. 76

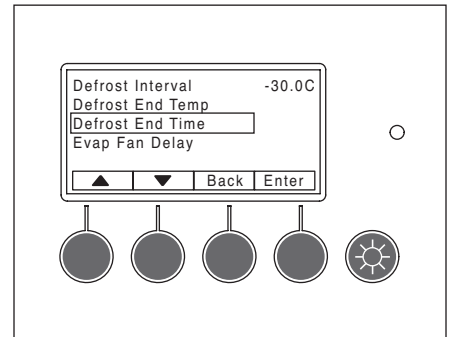

11. Use ▲/▼ to scroll and highlight **Evap Fan Delay** (Fig. 77), press **Enter** to view.
When defrost terminates on time (30 minutes) or temperature (5.0 C (41.0 F)), the evap fan is delayed for 6 minutes. This delay allows additional moisture to drip off the evap coil for 2 minutes (drip time delay) and refreezing of the coil for an additional 4 minutes before the evap fan restarts. This prevents warm air and moisture from blowing onto the cabinet after defrost. *Consult Technical Service prior to changing.*
12. Press **Back** to return to the **Evap Fan Delay** screen.

Fig. 77

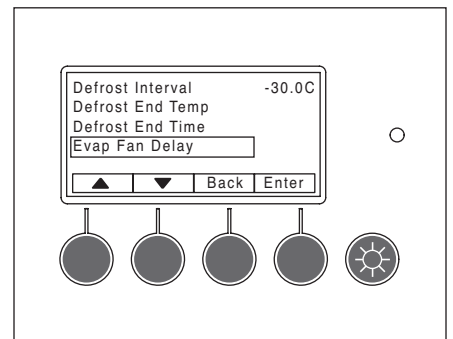

13. Use ▲/▼ to scroll and highlight **Drip Delay** (Fig. 78), press **Enter** to view.
There is a 2 minute drip time delay after defrost terminates to allow additional moisture to drain off the coil before the compressor and condenser fan cycle on. After an additional 4 minutes, for a total of 6 minutes, the evap fan restarts. This prevents warm air and moisture from blowing onto the cabinet after defrost. *Consult Technical Service prior to changing.*
14. Press **Back** to return to the **Drip Delay** screen.

Fig. 78

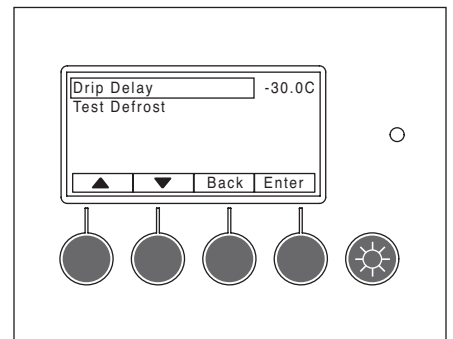

Test defrost/manual defrost

1. Complete steps 1-4 in the Defrost Setting section (page 26).
2. Use ▲/▼ to scroll and highlight **Test defrost** (Fig. 79).

To initiate a manual defrost, **press and hold Enter and Down (▼) button for 3 seconds**.

The manual defrost cycle will terminate in the same manner as an automatic defrost (i.e., on time or temperature).

3. Press **Back** until the main screen is displayed.

Fig. 79

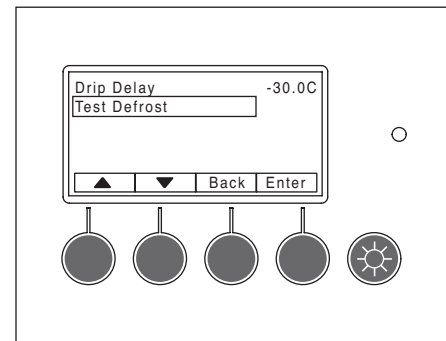

Fig. 80

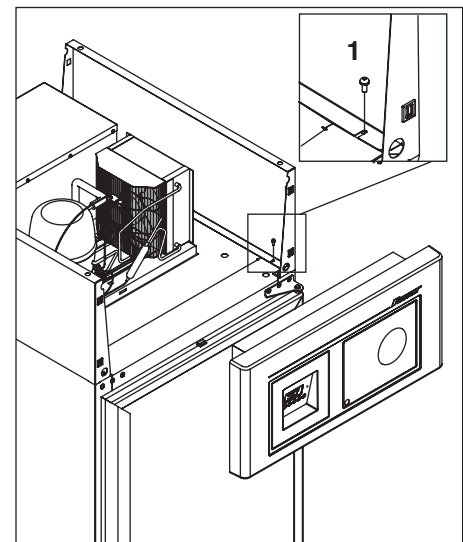
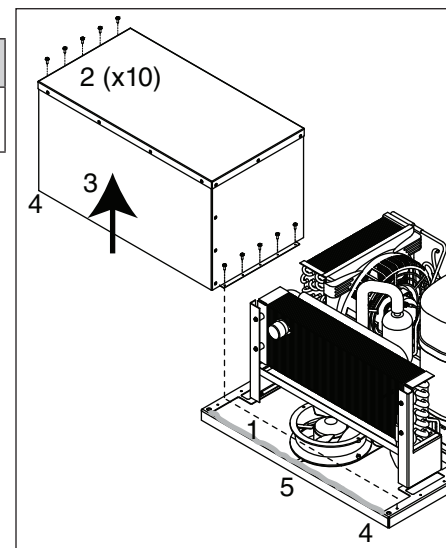

Fig. 81



Facade removal

The facade is removed by loosening the top left and right Phillips screws on the back of the facade to allow the securing clips to rotate away from the side panels. The facade can simply pull off of the front by pulling it out of the bayonet mounts that secure it to the upper left and right panels. If the facade will be completely removed, the electrical plugs should be disconnected. The ground wire should be removed from the top right grounding screw on the cabinet box, not from the facade (Fig. 80.1).

Evaporator cover removal and reinstallation



⚠ CAUTION

- To avoid equipment damage, do not remove evaporator cover until freezer temperature is >10 C (>50 F).

To avoid damaging the cover, you must allow sufficient time for the unit to defrost prior to removing the cover. You can put unit through a manual defrost to speed the process (see Test defrost/manual defrost section).

1. Cut silicon sealant on back of evaporator cover to allow removal (Fig. 81.1).
2. Using a 1/4" socket with an extension of at least 11", remove the 5 sheet metal screws on each side of the evaporator cover (Fig. 81.2).
3. Carefully pull permagum away from evaporator cover where refrigerant lines enter through cover.
4. Gently lift the cover straight up and off of the module and evaporator (Fig. 81.3).
5. Prior to reinstalling the evaporator cover, remove all of the old silicon sealant from the back of the evaporator cover and base (Fig. 81.4).
6. After installing evaporator cover and screws, apply a bead of silicon sealant to back seam of evaporator cover and base (Fig. 81.5).
7. Re-adhere permagum around utility penetration opening on evaporator cover.

Controller replacement

 CAUTION	
	<ul style="list-style-type: none">• Controller board is susceptible to electrostatic discharge. Extreme care should be exercised by using a grounding strap when handling and installing control board.

1. Turn off power to unit and unplug.
2. Remove facade and disconnect electrical plugs.
3. Remove screw securing ground screw to refrigerator cabinet (Fig. 82.1). Do not remove ground wire from facade.
4. Place facade face down on flat clean surface with bottom of facade facing you, and remove four screws attaching back panel to facade.
5. Lift and rotate back panel toward you.
6. Take precautions for proper grounding to reduce risk of electrostatic discharge (ESD) to the controller board.
7. Remove 5 screws securing board to facade (Fig. 82.2).
8. Reposition board away from mounting location and install new board.
9. Using wiring schematic (attached to inside of removed back panel) as a guide, remove wires one at a time from back of existing controller and connect to corresponding terminals on replacement controller.
10. If ribbon cable from the display is not connected, carefully connect to corresponding location on board (Fig. 82.3).
11. Make sure wiring is secured at same factory locations, so that cover will not pinch any wires when reinstalled.
12. Flip facade cover back into position on facade and reinstall 4 screws.
13. Place facade on top of refrigerator above compressor.
14. Reconnect electrical plugs and reinstall screw for grounding wire to grounding location on cabinet.
15. Remount facade to bayonet mounts.

Fig. 82

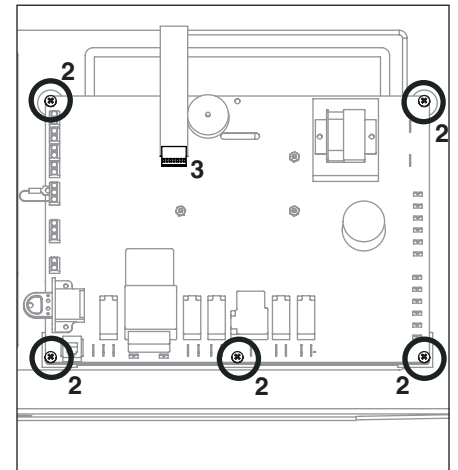

Reversing the door swing (requires a new door)

FZR20/25 units ship standard with a right hinged door. To change to a left hinged configuration requires a new door.

Door gasket replacement

1. Remove existing gasket from mounting track (Fig. 83).
2. Verify mounting track is free of any remaining gasket material.
3. Align new gasket with mounting track and press firmly in place.
4. Open and close door, checking for proper gasket seal without pinching against refrigerator.

Fig. 83

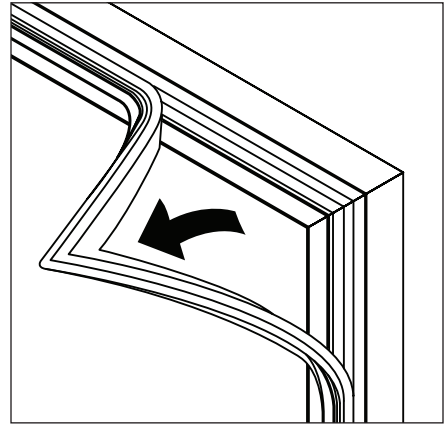

Slide-out unit cooler

Follett's slide-out refrigeration system allows technicians to remove the entire unit from the freezer top.

1. If necessary remove facade and upper side panels.
2. Remove four bolts securing unit cooler to refrigerator top (Fig. 84).
3. Gently lift off cooler.

Fig. 84

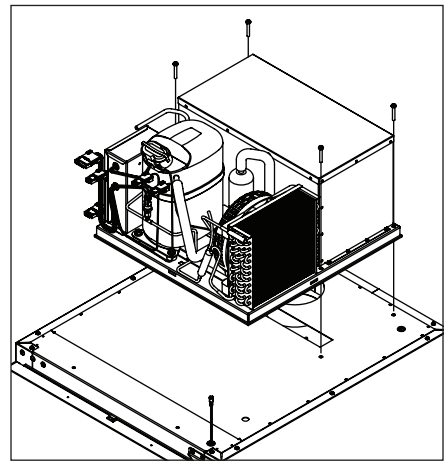

Wiring diagram

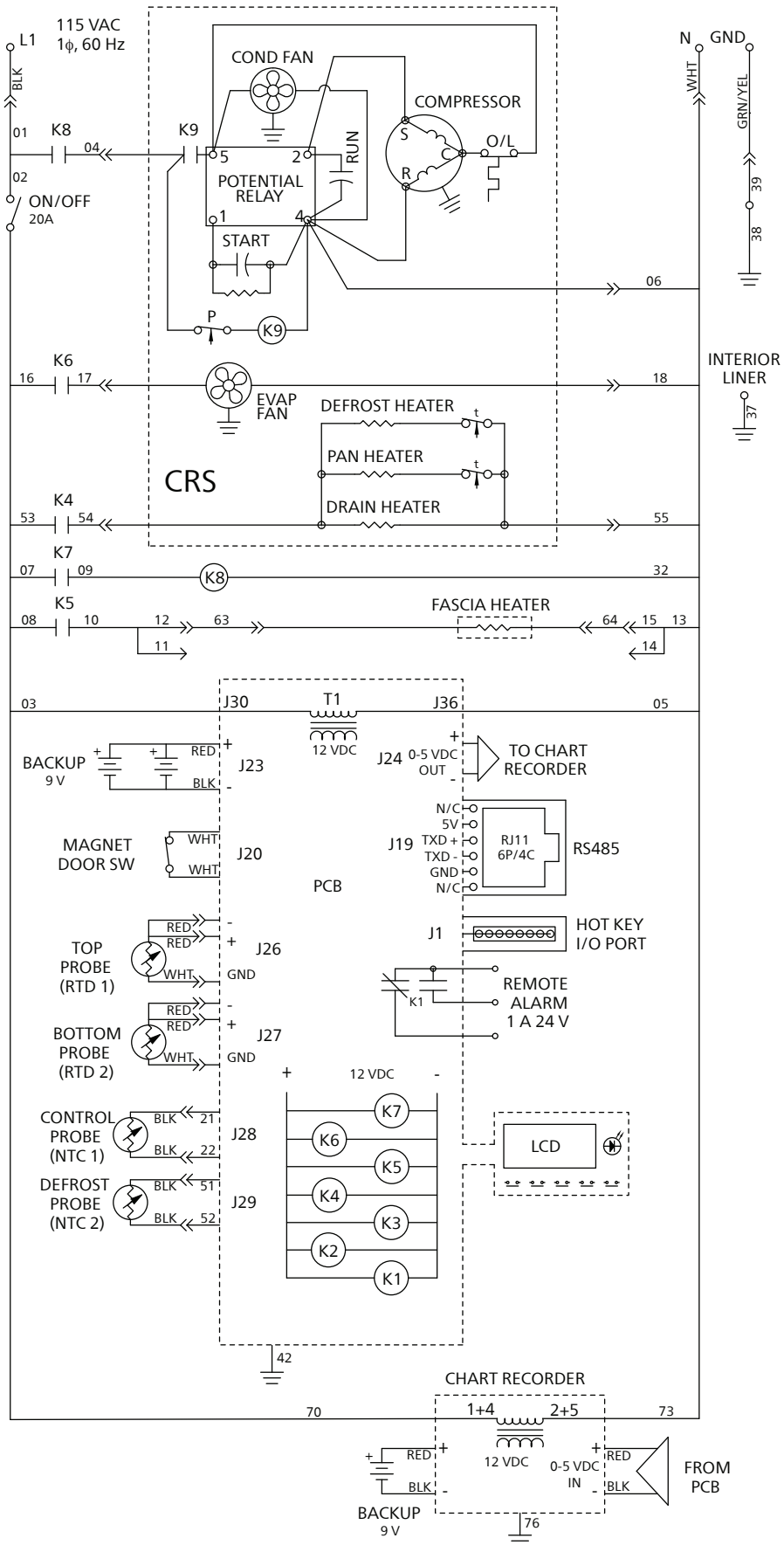

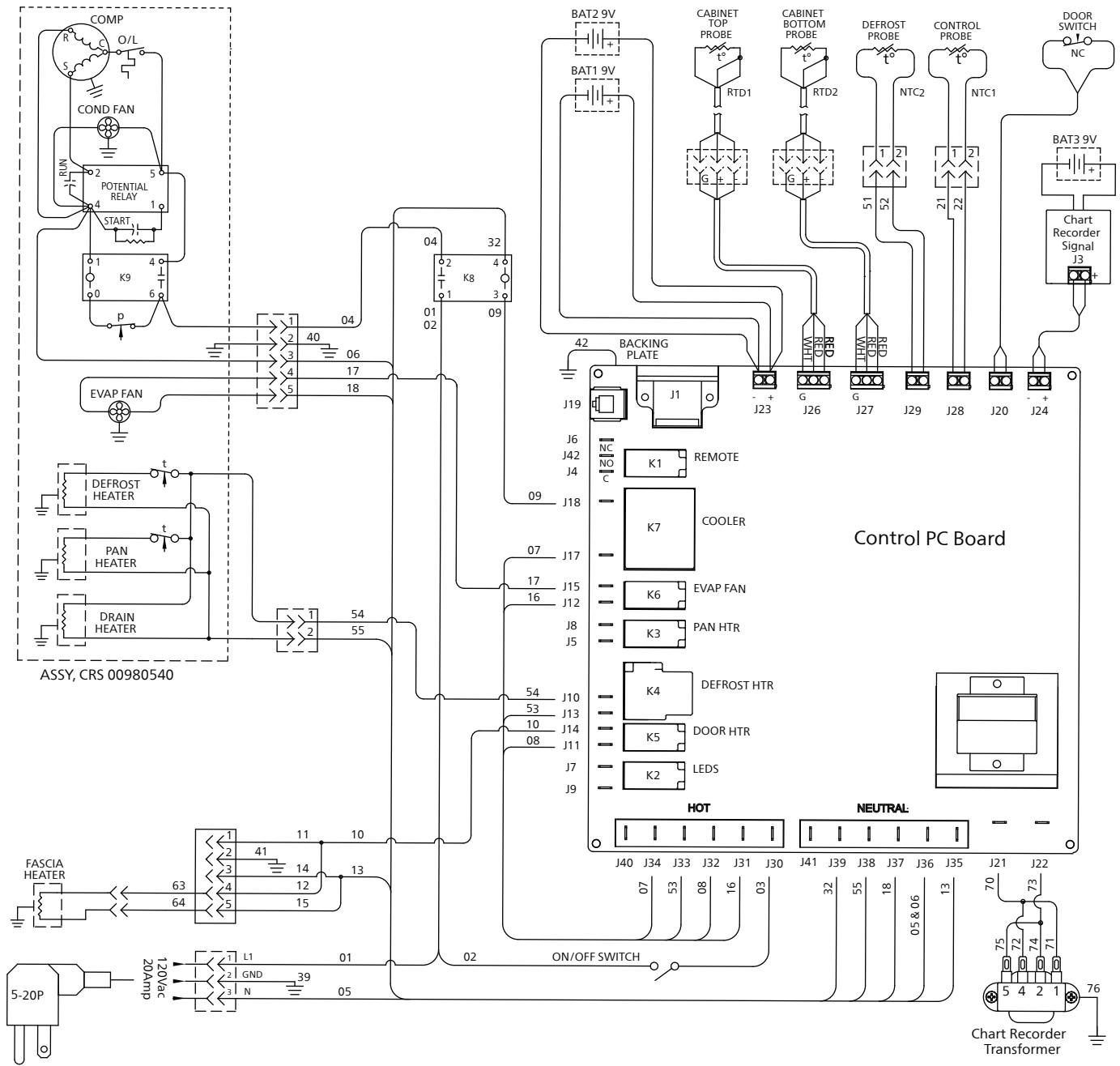

Compressor Data

Compressor	Current Draw
RLA max	9.8A
LRA	67A

Compressor Ohm Ratings

C-S	3.5Ω
C-R	0.7Ω
S-R	4.2Ω

Evaporator Fan Motor Data

RLA	0.28A
Ohm	38Ω or 95Ω

Condenser Fan Motor Data

RLA	0.58A
Ohm	35Ω

Defrost Heater Data

Evaporator Heater		
400 W	2.98A—4.0A	31Ω—35Ω
Drain Pan Heater		
85 W	0.63A—0.86A	148Ω—163Ω
Drain Tube Heater		
15 W	0.11A—0.15A	909Ω-1005Ω
Total in parallel	3.88A—5.24A	25Ω—28Ω

Fascia Heater Data

70 W	0.47A—0.65A	196Ω—216Ω
------	-------------	-----------

Troubleshooting

Before calling for service

1. Check that unit is plugged in.
2. Test outlet with another appliance to verify power.

Problem	Indicators	Corrective Action
Freezer does not operate (no components run).	1. Power switch faulty or in OFF position; loose connection.	1. Turn power switch to ON position; check switch and connections.
	2. Freezer not plugged in.	2. Connect plug.
	3. No power at outlet or low voltage.	3. Restore power or correct voltage.
	4. Temp controller not energizing components.	4. Check controller contact terminals for power. Replace controller if needed.
	5. Probe not sensing cut-in temperature.	5. Replace controller and/or probe.
Compressor does not run.	1. Thermal overload open or defective.	1. Allow to cool or replace.
	2. Capacitor and/or relay defective.	2. Replace as required.
	3. Compressor defective.	3. Replace compressor.
	4. HP switch open or faulty.	4. Allow to cool or replace HP switch.
Evaporator fan motor does not run.	1. Defective fan motor.	1. Replace fan motor
Freezer does not shutoff.	1. Controller not sensing cut out temperature.	1. Replace controller and/or probe.
	2. Controller keeping refrigeration system energized.	2. Replace controller.
Freezer does not maintain temperature (all components run).	1. Condenser coil needs cleaning.	1. Clean coil as needed.
	2. Door not closing.	2. Adjust door closure per page 5.
	3. Excessively high ambient.	3. Maximum recommended ambient is 86 F (30 F).
	4. Refrigerant leak.	4. Locate and repair leak.
	5. Incorrect refrigerant charge.	5. Recover, evacuate and weigh in correct charge.
	6. Restricted or faulty TXV..	6. Replace TXV.
	7. Inefficient compressor.	7. Consult technical service.
	8. Faulty door gasket.	8. Replace door gasket
	9. The top air return has ice accumulating in it.	9. Shine a flashlight into return at top. If ice is accumulating, defrost completely.

If problems persist after following this basic troubleshooting guide, call Follett's technical service group at (877) 612-5086 or +1 (610) 252-7301.

Appendix

Control key functions

 **MENU** Enter main menu

 **Back** Return to prior

 Buttons to select screen options

 **▲** Scroll up

 **ENTER** Select

 Cabinet light ON/OFF

 **▼** Scroll down

 **MUTE** Mutes alarm

 Alarm light

Menu Navigation table

Main Menu	Submenu	Default Setting	Range	Notes	
Alarm Settings	High Alarm Set	40 C	40 C to Lo Alarm	Default is set high to not alarm on initial cool down	
	Low Alarm Set	-40 C	-40 C to Hi Alarm		
Display Settings	Show Bottom Temp	No	Yes / No	—	
	Display Inverse	Yes	Yes / No	Yes = light lettering with dark background	
	Degrees F/C	C	F or C	Displays temperatures in F or C	
Min/Max Temp	Min	—	—	Records min/max temperature and time of top probe. Up/down arrow displays min/max. Enter to reset.	
Batt = _V OK	—	—	—	Shows status of (2) 9 V batteries	
Refrigeration Controls (ENTER + ▼ for 3 s)	Calibration	Cal Top Probe	—	—	Adjust with up/down arrow, press enter to set
		Cal Bottom Probe	—	—	Adjust with up/down arrow, press enter to set
	Refrigeration Setpoint:				—
		PL	-31 C	40 C to -40 C	
		LB	-24 C	40 C to -40 C	
	Differential		1 C	1 to 2 C	—
	Hi Setpoint Limit		-15 C	40 C to Lo Set Pt	—
	Lo Setpoint Limit		-32 C	-40 C to Hi Set Pt	—
	Door Heater Cycle		75%	0 to 100%	0 to 100% of 20 minute cycle
	Faulty Probe Cycle	On Time	6 min	2 to 14 min	Compressor On time
		Off Time	5 min	2 to 14 min	Compressor Off time
	Temp Sensors		—	—	RTD1, RTD2, NTC1 and NTC2 displayed
	Defrost	Defrost Interval	4 hrs	2 to 6 hrs	Time between defrosts.
Defrost End Temp		5 C	5 to 10 C	Temperature that terminates defrost	
Defrost End Time		30 min	10 to 60 min	Time that terminates defrost	
Evap Fan Delay		6 min	4 to 6 min	Fan start delay after defrost terminates	
Drip Delay		2 min	0 to 2 min	Delays compressor start after defrost terminates	
Test Defrost		—	—	Press ENTER + ▼ for 3 seconds to initiate	
Password On/Off	—	Off	On / Off	—	
PIN	—	3843	0000 to 9999	Any four digit PIN can be stored in addition to the permanent factory default. Adjust with up/down arrow, NEXT moves to next digit, press ENTER to set.	
Set Time / Date	YYYY MM DD HH:MM		00:00 to 24:00	Adjust with up/down arrow, NEXT moves to next digit, press ENTER to set.	
Set Alarm Volume	—	High	High/Med/Low	Buzzer Volume	
Alarm Silence	Audible alarm	On	On / Off	Audible alarm	

Replacement parts

Unit cooler

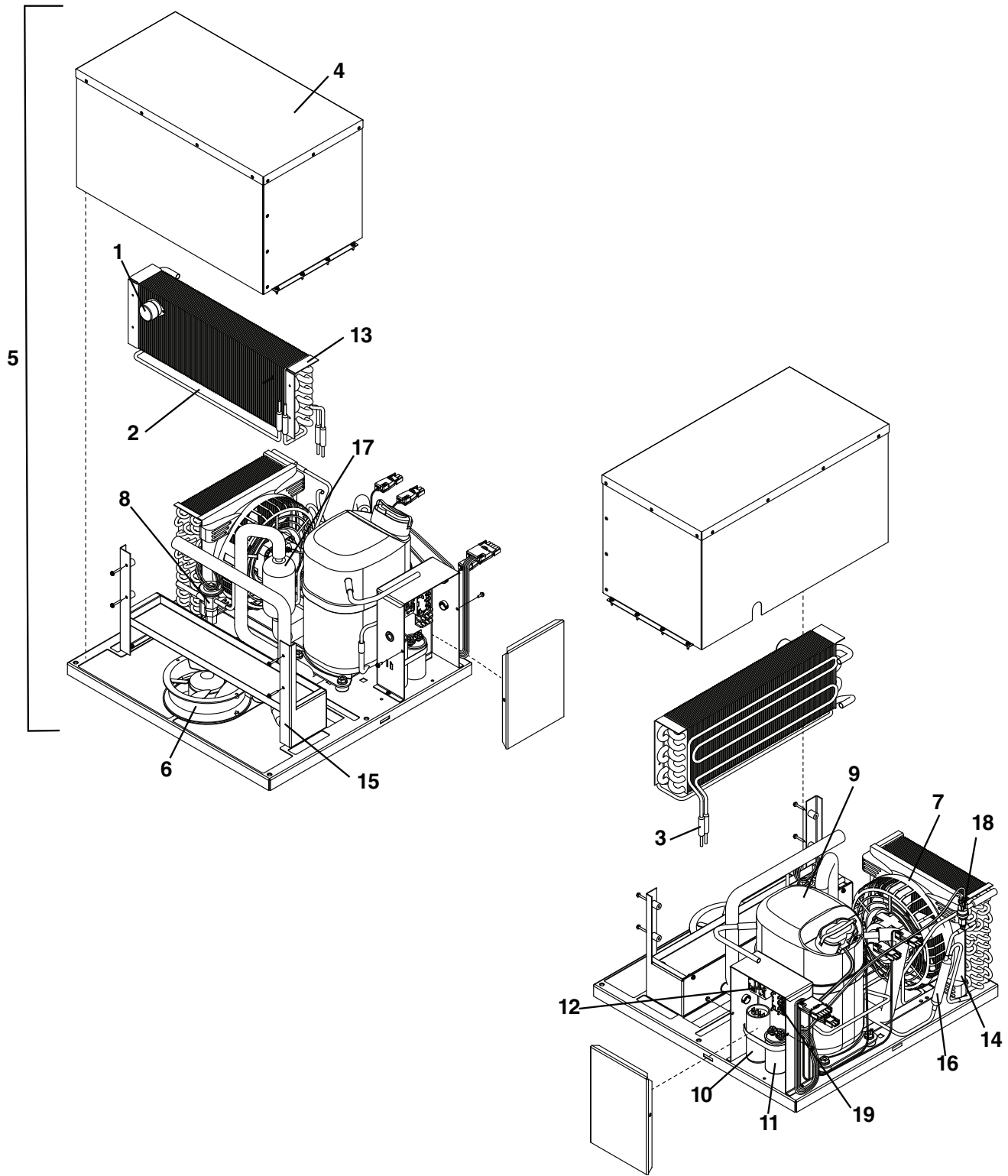

Reference	Description	Part #
1	Thermal overload, evaporator heater	01002294
Not shown	Thermal overload, drain pan heater	00996504
Not shown	Condensate drain tube with trap	00996512
Not shown	Heater, condensate drain tube	00996496
2	Defrost heater, drain pan	00996488
3	Defrost heater, evaporator (includes clips)	01002732
4	Evaporator cover (includes screws)	01002831
Not shown	Gasket, unit cooler	00912980
Not shown	Probe, evaporator, NTC (defrost probe also)	00940148
5	FZR cooling unit (includes gasket and mounting bolts)	01007004
6	Evaporator fan motor with blade	01025774
7	FZR condenser fan motor with blade	00996447
8	TXV FZR 20/25 (includes clamps and insulation)	00996462
9	Compressor (includes overload and mounting grommets)	00996371
10	Start capacitor	00996397
11	Run capacitor	00996405
12	Potential relay	01002724
Not shown	Compressor overload	00996389
13	Evaporator (includes associated refrigerant tubing and insulation)	01002385
14	Shroud, condenser fan motor	00996454
Not shown	Cord and plug kit, FZR	00996595
15	Mounting bracket, evaporator	01002401
16	Filter drier	00996546
17	Accumulator (includes insulation)	00996538
18	HP switch	00996421
19	Contactors	01003581

Cabinet

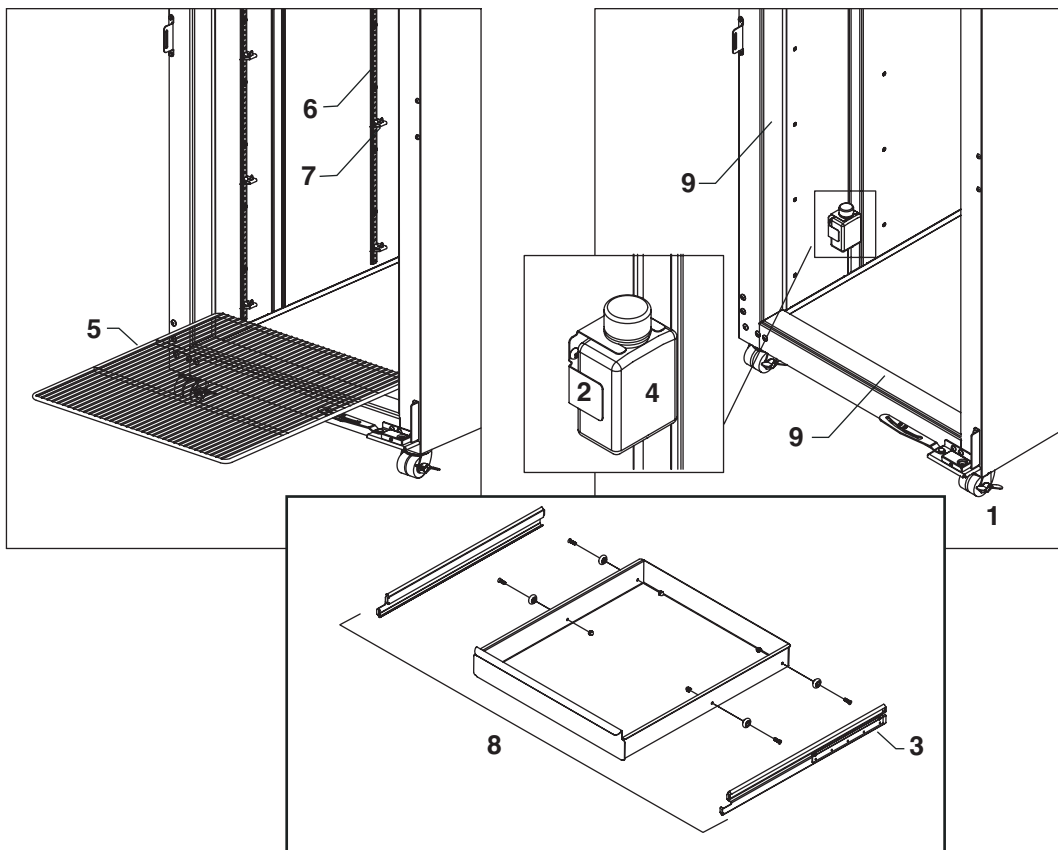

Reference	Description	Part #
1	Caster, swivel with brake	00187674
2	Bracket, bottle, 125ML	00171132
3	Slide, drawer, FZR25 (set of 2)	00193045
3	Slide, drawer, FZR20 (set of 2)	00188367
4	Bottle with gasket	01015817
5	Shelf, FZR25 (with supports)	01015841
5	Shelf, FZR20 (with supports)	01015858
6	Pilaster (with screws)	01015866
7	Shelf supports (qty. 1), 4 needed per shelf	00156240
8	Drawer assembly, FZR25	01015791
8	Drawer assembly, FZR20	01015809
9	Kit, fascia heater with thermal break covers	01015882
Not shown	Air panel, FZR20/25 PL	00978569
Not shown	Air panel, FZR20/25 LB	00901561
Not shown	Probe channel	01004159
Not shown	Probe, RTD, top	00918839
Not shown	Probe, RTD, NIST calibrated, top	01101096
Not shown	Probe, RTD, bottom, PL models only	00988055
Not shown	Probe, RTD, NIST calibrated, bottom, PL only	01101104

Facade

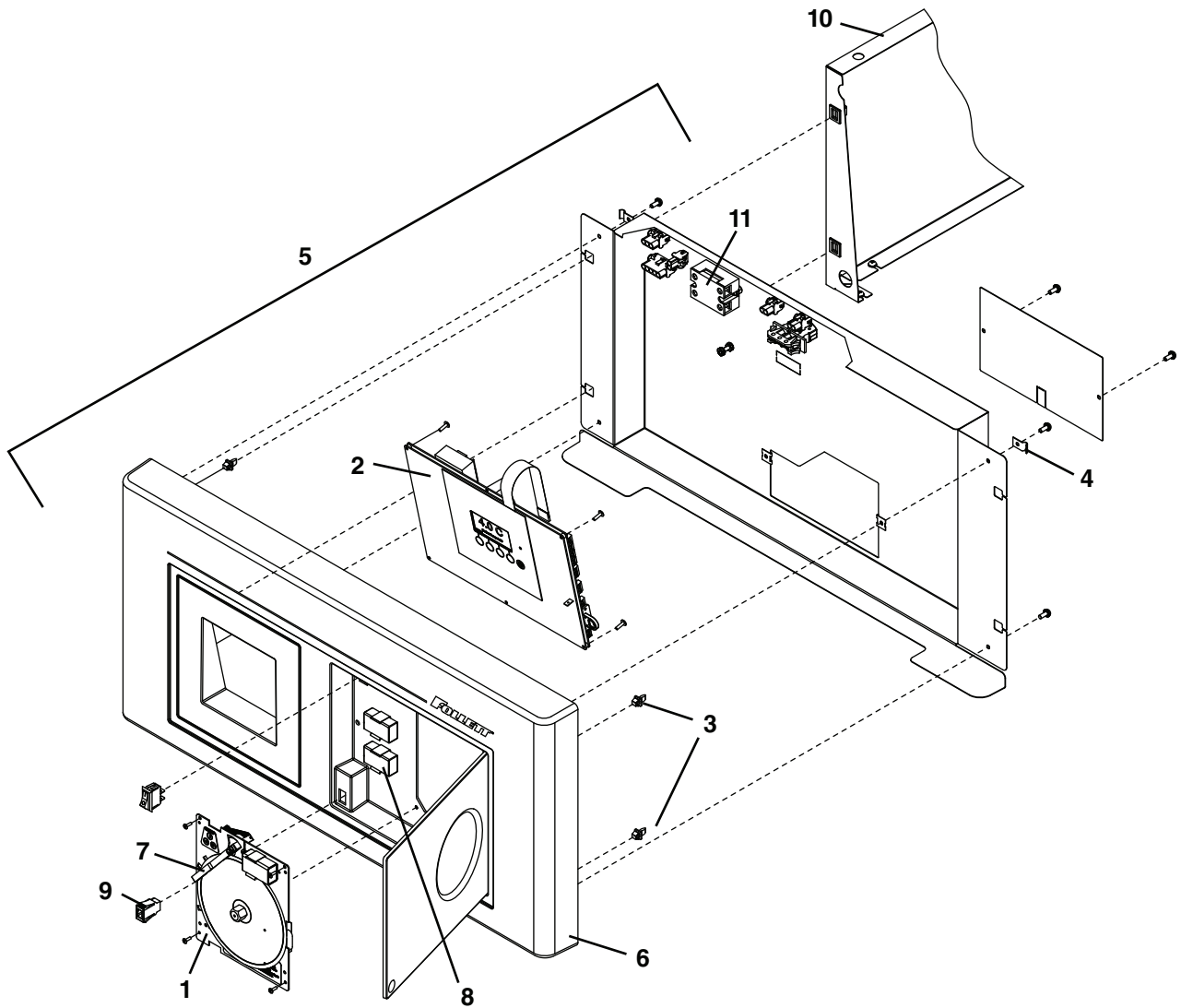

Reference	Description	Part #
1	Chart recorder	00980862
2	Controller	00918607
Not shown	Kit, door switch	00939959
3	Male, bayonet (strike, snap)	00179549
4	Facade, locking clip	00931501
5	Complete facade assembly with chart recorder	00996553
Not shown	Complete facade assembly without chart recorder	00996561
6	Facade, front cover only for units with charter recorder	00940130
Not shown	Facade, front cover only for units with charter recorder	00940155
7	Pens, chart recorder, red (box of 6)	00918813
Not shown	Charts FZR (box of 50) in degrees C	00980870
Not shown	Charts FZR (box of 50) in degrees F	00980888
8	Battery, 9V	00112177
9	Fastener, latch	00179556
10	Upper side panel FZR25	00940098
10	Upper side panel FZR20	00925933
Not shown	Top ventilated cover	00991760
Not shown	Control relay, compressor	00980482
Not shown	Back support	00991695

Door assembly

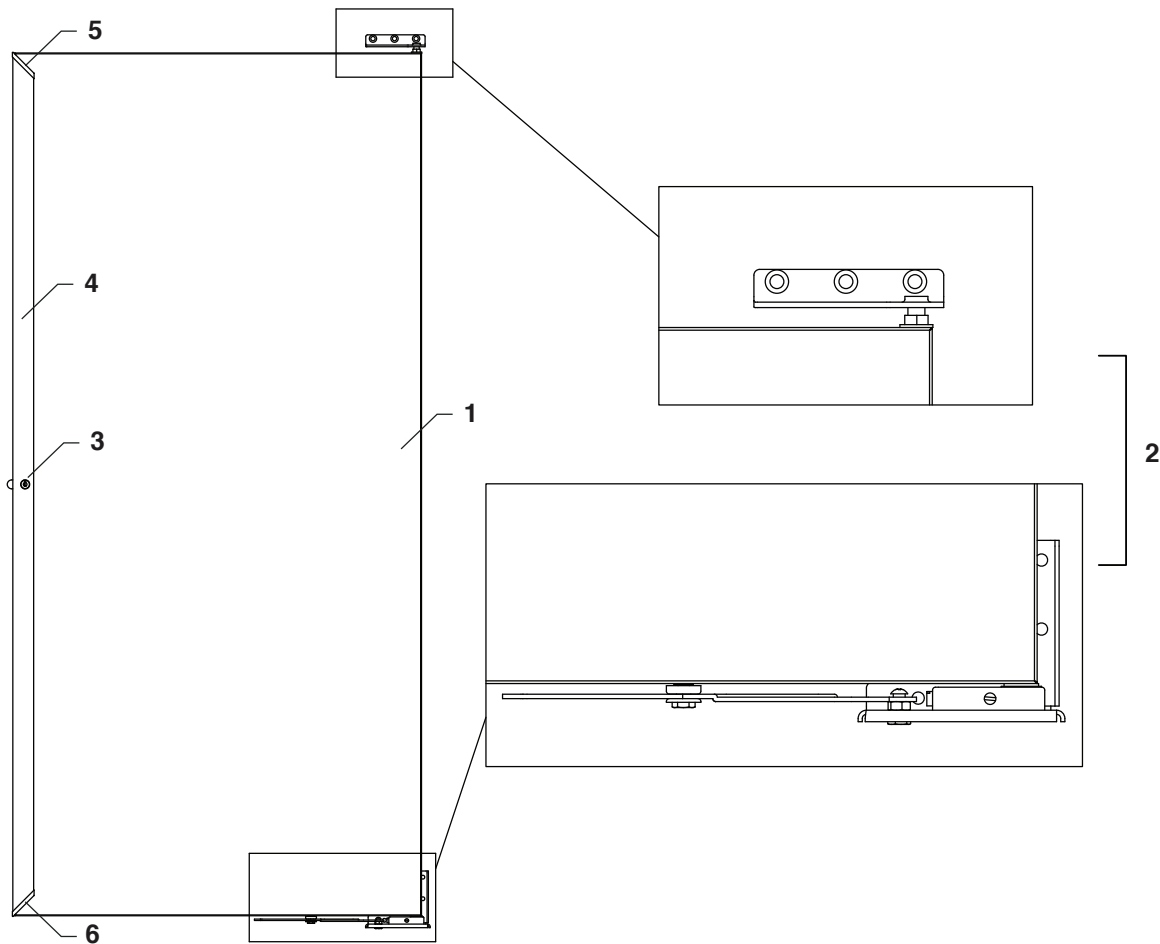

Reference	Description	Part #
Not shown	Door gasket	00960344
Not shown	Left-hand hinged door with hinges	00996611
1	Right-hand hinged door with hinges	00996603
Not shown	Left-hand hinges and hardware	00996587
2	Right-hand hinges and hardware	00996579
Not shown	Door magnet kit	00939967
Not shown	Bracket, door lock strike	00939983
Not shown	FZR door key	01035013
3	Lock, door	00996629
Not shown	Wall bracket kit, seismic anchoring	00927194
4	Door handle kit	00996637
5	Molded door handle cap, top	00989251
6	Molded door handle cap, bottom	00989244

Follett is a registered trademark of Follett Corporation, registered in the US.

Follett is a registered trademark of Follett Corporation, registered in US.



801 Church Lane • Easton, PA 18040, USA
Toll free (877) 612-5086 • +1 (610) 252-7301
www.follettice.com



00981795R03
© Follett Corporation 2/16