

# Water filter system

bacterial retentive



Filter system compatibility	Item number
Filter Assembly includes 0.2 µm double layer sterilizing-grade filter capsule, an 1 µm absolute rated pre-filter cartridge and a pressure regulator	01233659
Replacement filter kit includes 0.2 µm double layer sterilizing-grade filter capsule and an 1 µm absolute rated pre-filter cartridge	01244615

## Features

Kleenpak® 0.2 µm double layer sterilizing-grade disposable filter capsule with robust Supor® membranes and broad chemical compatibility<sup>1</sup>

Validated according to industry standard test methods with complete retention of the challenge organisms<sup>2</sup>

In-use evaluation performance supporting up to 6 months filter life

Profile II® 1 µm absolute rated pre-filter cartridge, with depth style polypropylene membrane for high performance particle removal

High efficiency pre-filtration ensuring removal of nutrient rich particulates

Barrier to protect the downstream sterilizing-grade filter capsule

Shurflo® pressure regulator controls water pressure to a maximum of 50 psi

Can be used in-line with scale inhibiting filtration systems

Non-carbon filtration, no use of glues or resins

NSF 42 listed system certified to reduce impurities

Supports ASHRAE 188 water management plans to provide barrier to waterborne bacteria from the incoming water

Retains microorganisms without volume restriction

### <sup>1</sup> Systemic Compatibility

Continuous chlorine dioxide disinfection (up to 1 ppm ClO<sub>2</sub>)

Chlorine shock treatment (up to 100 ppm free chlorine for up to 1 hour at ambient temperature)

Continuous free chlorine disinfection (up to 3 ppm at ambient temperature)

pH 12.8 (up to 1 hour at ambient temperature) ammonium chlorides, iodides and non-ionic surfactants)

Peracetic acid (up to 1000 ppm at 60 C for up to 2 hours)

### <sup>2</sup> F838-15a "American Standard Testing Methodology (ASTM) F838-15a determining bacterial infection of membrane filters utilized for liquid filtration, 2015"

Job

Item

## Specification

<b>W1</b> Width	10.5" (26.7 cm)
Depth	5.00" (12.7 cm)
<b>H1</b> Height	15.5" (39.4 cm)
Service clearance	2.50" (6.35 cm) at top and bottom for cartridge removal, 2.00" (5.08 cm) on each side
<b>C1</b> Water inlet	1/2" FNPT
<b>C2</b> Water outlet (to dispenser)	1/2" MNPT
<b>C3</b> Pre-filter	1 µm absolute rated pre-filter cartridge
<b>C4</b> Primary filter	0.2 µm sterilizing-grade disposable filter capsule
<b>C5</b> Pressure regulator	
Filter life	Validated for up to 6 months filter life
Water temperature	45 - 90 F (7 - 32 C)
Water pressure	30 - 70 psi (207 - 482 kpa)
Approximate ship weight	6 lb (2.7 kg)

NOTE: Follett bacterial-retentive water filter system includes Kleenpak 0.2 µm double layer sterilizing-grade disposable filter capsule, Profile II 1 µm absolute rated pre-filter cartridge and Shurflo pressure regulator. It has been validated as a complete assembly and operating outside those parameters voids the warranty.

## Dimensional drawing

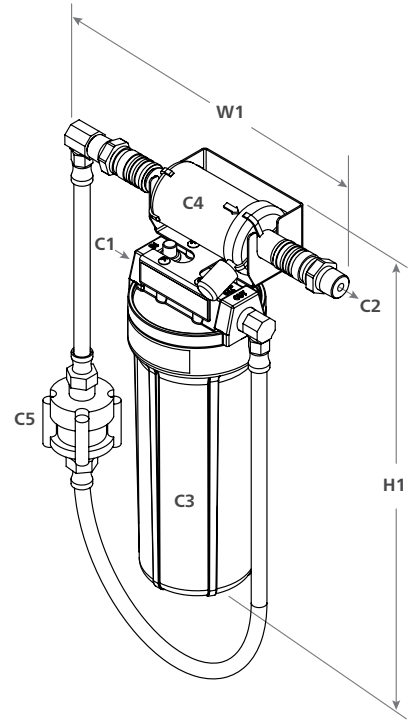

Kleenpak, Pall, Profile II and Supor are registered trademarks of Pall Corporation.

Shurflo is a registered trademark of Pentair.

Follett is a registered trademark of Follett LLC, registered in the US.

Follett reserves the right to change specifications at any time without obligation. Certifications may vary depending on country of origin.

Filters provided by

