

7 Series ice and water dispenser

Chewblet® ice machine



Shown with optional base stand

NOTE: For use in applications with greater than 5 mg/l but less than 400 mg/l total dissolved solids in water and less than 200 mg/l hardness (either naturally occurring or treated with reverse osmosis or other TDS reducing technology).

Not recommended for use with softened water.



Features

Compact size, only 17.62" (44.8 cm) tall to fit on counters under standard cabinets

7 lb (3.2 kg) ice storage capacity

Integral air-cooled ice machine with up to 125 lb (56.7 kg) daily production of popular Chewblet ice

- designed to serve up to 25 people (140 servings per 10 hr day¹)
- soft, chewable, compressed nugget ice is preferred over cubes²
- environmentally responsible R134a refrigerant with zero ozone depletion potential
- energy saving sleep mode
- quiet production without noisy harvest cycles
- meets the Consortium for Energy Efficiency (CEE) Tier 2 specifications for highly efficient ice machines
- ice-only models ENERGY STAR® certified³

Durable, attractive dispenser

- modern styling, stainless steel exterior with accent trim
- dispense-activated soft blue light illuminates point-of-use
- easy-to-clean, removable 20 oz (591 ml) drip tray

Designed with sanitation in mind

- Agion® silver-based antimicrobial product protection of key ice and water contact components⁴
- capacitive touch controls eliminate direct contact with ice

Installation

- comes fully assembled
- two easy connections – electric and water
- drainless design allows dispenser to be placed anywhere a water line can be run and eliminates the cost of a drain installation

Warranty

- 2 years parts and labor, 5 years compressor parts
- optional extended third year warranty (item# 00960732)

Accessories

- 4.00" (10.16 cm) leg kit for CI - countertop models (item# 00956300)
 - 6.00" (15.24 cm) leg kit for base stand (item# 00956318)
 - Drip tray drain kit for countertop models (includes 4.00" (10.16 cm) legs) (item# 00981977)
 - Drip tray drain kit without 4.00" (10.16 cm) legs (item# 00956375)
 - SafeCLEAN Plus™ ice machine cleaner
 - 1 x 8 oz (237 ml) bottle (item# 01147826)
 - 6 x 8 oz (237 ml) bottles (item# 01149954)
 - Carton of 24 x 8 oz (237 ml) bottles (item# 01149962)
 - Cartridge, replacement 5 micron particle/carbon (item# 00968107)
- For additional water treatment and other accessories refer to form# 4025

Model configurations			
Ice storage capacity	Configuration	Filter ¹	Item number
7 lb (3.2 kg)	countertop ice and water	no filter	7CI100A-IW-NF-ST-00
		internal	7CI100A-IW-CF-ST-00
	countertop ice-only	no filter	7CI100A-NW-NF-ST-00†
		internal	7CI100A-NW-CF-ST-00†
For freestanding models			
Optional base stand to convert countertop models to freestanding			00956292

† ENERGY STAR certified.

¹ Internal filter is a 5 micron particle and carbon filter.

Job

Item

801 Church Lane | Easton, PA 18040, USA
1.800.523.9361 | 1.610.252.7301 | follettice.com

FOLLETT®

Specification

Ice storage capacity	7 lb (3.2 kg)
W1 Width	14.62" (37.1 cm)
D1 Depth	22.12" (56.2 cm)
H1 Height, countertop models	17.62" (44.8 cm)
H2 Height, with optional base stand	42.00" (106.7 cm)
H3 Height, optional base stand	24.50" (62.2 cm)
H4 Dispense height clearance	8.50" (21.59 cm)
Ventilation clearance	3.00" (7.62 cm) on each side
Service clearance	3.00" (7.62 cm) behind and on each side
C1 115 V/60/1 electrical	5 amps, 0.26 kW Connect to dedicated 15 amp circuit, fuse or breaker. 8' (2.4 m) cord w/ NEMA 5-15 90° plug.
C2 Water inlet	1/4" MPT
Air temperature	50 - 100 F (10 - 38 C)
Water temperature	40 - 90 F (4 - 32 C)
Water pressure	10 - 70 psi (69 - 482 kpa)
Ice production at 70 F (21 C) air and 50 F (10 C) water	125 lb (56.7 kg)
Ice production at 90 F (32 C) air and 70 F (21 C) water	100 lb (45.4 kg)
Energy consumption 90 F (32 C) air and 70 F (21 C) water	6.9 kWh per 100 lb (45.4 kg) ice
Heat rejection	1700 BTU/hr
Water consumption	12 gal (45.4 L) of potable water per 100 lb (45.4 kg) of ice
Approximate net weight – countertop models	74 lb (34 kg)
Approximate shipping weight – countertop models	90 lb (41 kg)
Approximate net weight – optional base stand	24 lb (11 kg)
Approximate shipping weight – optional base stand	30 lb (14 kg)

NOTE: For indoor use only. Designed for commercial use. Follett® is not able to provide in-house services for residential installations.

SHORT FORM SPECIFICATION: (Choose one) ____ Ice and water or ____ ice-only dispenser to be Follett automatic load in countertop configuration, with 7 lb (3.2 kg) of storage. Environmentally responsible R134a ice machine to be air-cooled. Ice machine to produce approximately 125 lb (56.7 kg) of Chewblet compressed nugget ice at air temperature of 70 F (21 C) and water temperature of 50 F (10 C). Ice machine to be equipped with printed circuit board and diagnostics to allow simplified servicing and with capacitive touch user interface. Storage area to be insulated with non-CFC, high density foam-in-place polyurethane. 8' (2.4 m) cord and NEMA 5-15 90° plug provided 115 V/60/1. NSF and ETL listed. For use in applications with greater than 5 mg/l but less than 400 mg/l total dissolved solids in water and less than 200 mg/l hardness (either naturally occurring or treated with reverse osmosis or other TDS reducing technology).

Dimensional drawing

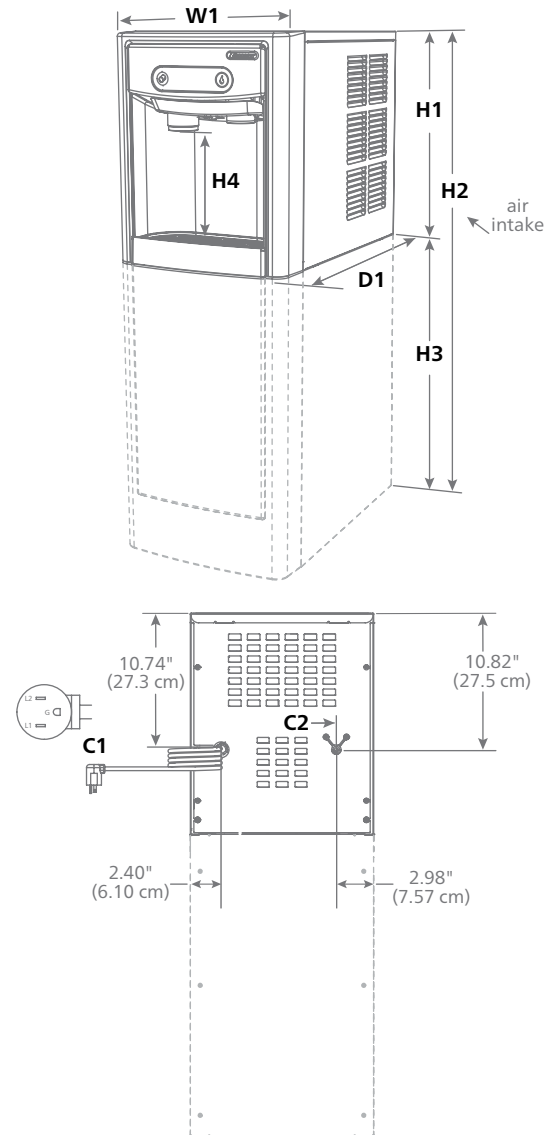

- 1 16 oz (473 ml) cups, 2/3 full of ice.
- 2 Independent third party studies. Contact Follett for details.
- 3 ENERGY STAR certification applies only to ice-only dispensers. While the 7 Series ice and water dispensers have the same efficient ice makers and refrigeration systems with the same ice machine electrical and water consumption as their complementary ice-only models, there is no ENERGY STAR category for ice and water dispensers at this time.
- 4 Disclaimer: Antimicrobial protection is limited to the treated components and does not treat water or ice.

Agion is a registered trademark of ScieSSent LLC.
ENERGY STAR and the ENERGY STAR mark are registered trademarks owned by the U.S. Environmental Protection Agency.
SafeCLEAN Plus is a trademark of Follett LLC.
Chewblet and Follett are registered trademarks of Follett LLC, registered in the US.
Follett reserves the right to change specifications at any time without obligation. Certifications may vary depending on country of origin.

7 Series ice and water dispenser