

# E7-RD Series ice and water dispenser with Chewblet® ice machine

rear draining countertop



Shown with optional base stand



## Features

Compact size, only 44.8 cm (17.62") tall to fit on counters under standard cabinets

3.2 kg (7 lb) ice storage capacity

Integral air-cooled ice machine with up to 54.4 kg (120 lb) daily production of popular Chewblet ice

- soft, chewable, compressed nugget ice is preferred over cubes<sup>1</sup>
- environmentally responsible R134a refrigerant with zero ozone depletion potential
- energy saving sleep mode
- quiet production without noisy harvest cycles

Durable, attractive dispenser

- modern styling, stainless steel exterior with accent trim
- dispense-activated soft blue light illuminates point-of-use
- easy-to-clean, removable 590 ml (20 oz) drip tray
- dispenser top can support 16 kg (35 lb)

Designed with sanitation in mind

- Agion® silver-based antimicrobial product protection of key ice and water contact components<sup>2</sup>
- sanitary ice dispense reduces chance of contamination

Installation

- comes fully assembled

Warranty

- 2 years parts and labor, 5 years compressor parts

Model configurations - 230 V 50 Hz		
Ice storage capacity	Configuration	Item number
<b>3.2 kg (7 lb)</b>	countertop ice and water	<b>E7CI100A-IW-NF-ST-RD</b>
	countertop ice-only	<b>E7CI100A-NW-NF-ST-RD</b>

## Accessories

- Base stand for converting countertop models (item# 00956292)
- 10.16 cm (4.00") leg kit for CI - countertop models (item# 00956300)
- 15.24 cm (6.00") leg kit for optional base stand (item# 00956318)
- Drip tray drain kit for countertop models (includes 10.16 cm (4.00") legs) (item# 00981977)
- Drip tray drain kit for models other than countertop (item# 00956375)
- Claris® hardness removal filtration system (item# 00986059)

Job

Item

Follett Europe Polska Sp. z o.o.  
 Mokry Dwór 26C 83-021 Wiślina, Poland  
 Phone: +48 (58) 785-6140 | Fax: +48 (58) 785-6159  
 folletteurope.com

801 Church Lane | Easton, PA 18040, USA  
 1.610.252.7301 | Fax: +1.610.250.0696 | follettice.com

**FOLLETT®**

## Specification

Ice storage capacity	3.2 kg (7 lb)
<b>W1</b> Width	37.1 cm (14.62")
<b>D1</b> Depth	56.2 cm (22.12")
<b>H1</b> Height – countertop models	44.8 cm (17.62")
<b>H2</b> Height with optional base stand	106.7 cm (42.00")
<b>H3</b> Height, optional base stand	62.0 cm (24.41")
<b>H4</b> Dispense height clearance	21.59 cm (8.50")
Ventilation clearance	7.62 cm (3.00") on each side
Service clearance	7.62 cm (3.00") behind and on each side of dispenser
<b>C1</b> 230 V/50/1 electrical	5 amps. Connect to dedicated 10 amp circuit, fuse or breaker. Dispenser has IEC 60320-C13 connector in rear of dispenser for use with appropriate modular cord.
<b>C2</b> Water inlet	1/4" MPT
<b>C3</b> Drain	1/2" ID
Air temperature	10 - 38 C (50 - 100 F)
Water temperature	4 - 32 C (40 - 90 F)
Water pressure	69 - 483 kpa (10 - 70 psi)
Ice production at 21 C (70 F) air and 10 C (50 F) water	54.4 kg (120 lb)
Ice production at 32 C (90 F) air and 21 C (70 F) water	40.8 kg (90 lb)
Energy consumption 32 C (90 F) air and 21 C (70 F) water	7.1 kWh per 45.4 kg (100 lb) ice
Heat rejection	498 W (1700 BTU/hr)
Water consumption	45.4 L (12 gal) of potable water per 45.4 kg (100 lb) of ice
Approximate net weight	34 kg (74 lb)
Approximate shipping weight	41 kg (90 lb)

NOTE: Intended for commercial use only. Follett can't guarantee freight carrier's ability to deliver to residential locations. Follett service providers may not be bonded to perform on-site warranty repairs in certain areas.

SHORT FORM SPECIFICATION: (Choose one) \_\_\_ Ice and water or \_\_\_ ice-only dispenser to be Follett® automatic load in countertop configuration, with 3.2 kg (7 lb) of storage. Environmentally responsible R134a ice machine to be air-cooled. Ice machine to produce approximately 54.4 kg (120 lb) of Chewblet compressed nugget ice at air temperature of 21 C (70 F) and water temperature of 10 C (50 F). Ice machine to be equipped with printed circuit board and diagnostics to allow simplified servicing and with capacitive touch user interface. Storage area to be insulated with non-CFC, high density foam-in-place polyurethane. 230 V/50/1. Dispenser has IEC 60320-C13 connector in rear of dispenser for use with appropriate modular cord. CE listed.

## Dimensional drawing

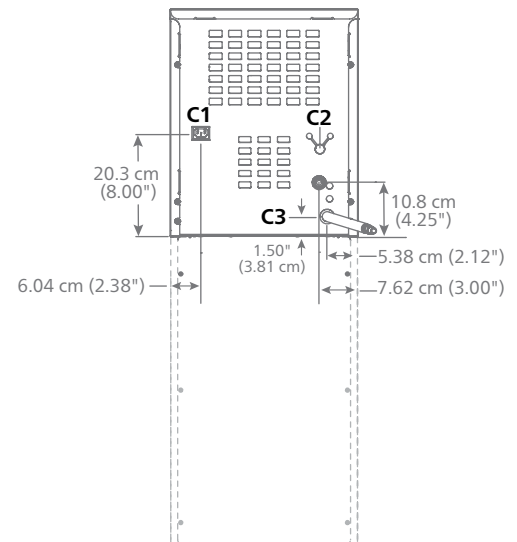
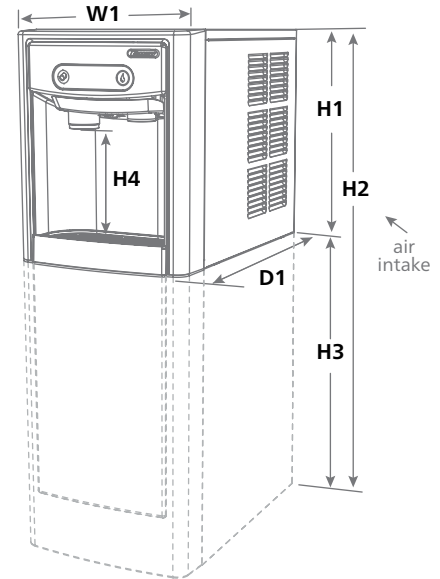

<sup>1</sup> Independent third party studies. Contact Follett for details.

<sup>2</sup> Disclaimer: Antimicrobial protection is limited to the treated components and does not treat water or ice.

Claris is a registered trademark of the Aquis GmbH in Switzerland.

Agion is a registered trademark of Sciessent LLC.

Chewblet and Follett are registered trademarks of Follett LLC, registered in the US.

Follett reserves the right to change specifications at any time without obligation. Certifications may vary depending on country of origin.