

# Maestro Plus™

ice machine for healthcare applications



Model MCD425ABT shown



## Features

Maestro Plus ice machine with up to 425 lb (193.0 kg) daily production of Chewblet® or flake ice.

### High performance Maestro Plus ice machines

- compact, reliable ice machine for top mount installation
- stainless steel evaporator, auger and top bearing
- oversized, heavy duty, tapered roller bearing ensures long low-maintenance life
- automatic self-flushing of ice machine removes impurities
- no noisy harvest cycles means quiet ice production

### Lower utility bills

- energy-efficient, no costly defrost cycles
- 25% less energy than comparable capacity cube machines
- 40% less water than comparable capacity cube machines

### Maintenance and service benefits

- cleaning and sanitizing of entire machine takes less than 1 hour
- LED control board provides at-a-glance machine status

### Flake ice (MFD models) for clinical labs, rehab and medical research

- high surface area of flake ice chills quickly, maintains samples at desired temperature
- holds test tubes and lab vials securely, even when ice is melting
- molds well in ice bag and rehab applications for best skin contact and swelling control

### Chewblet ice (MCD models)

- preferred over cubes by more than 2:1<sup>1</sup>
- easy to chew
- more reliable dispensing than nugget or pellet ice
- slow melting, maintains drink temperature and quality, comparable to cubes
- higher displacement than cube ice

### Installation flexibility

- Harmony™ kits allow ice machine to be top mounted on most ice and beverage dispensers
- Harmony kits install without any alteration to dispenser (kit includes stainless steel top)
- compatible with over 20 of Follett's ice storage bins

### Warranty

- 3 years parts and labor, 5 years compressor parts

<sup>1</sup> Consumer study conducted by independent agency Roper ASW.

Model configurations			
Ice type	For use with <sup>1</sup>	Condenser	Item number
Flake	ice storage bin	air	MFD425ABT†
		water	MFD425WBT
Chewblet	ice storage bin	air	MCD425ABT†
		water	MCD425WBT
	countertop ice and beverage dispenser (by others)	air	MCD425AHT†
		water	MCD425WHT

† ENERGY STAR® certified

<sup>1</sup> Ordered separately

Job \_\_\_\_\_  
 Item \_\_\_\_\_

## Specification for bin top mount ice machines

<b>W1</b> Width	22.70" (57.6 cm) fits on 22.00" wide dispensers or bins
<b>D1</b> Depth, ice machine	24.25" (61.6 cm)
<b>D2</b> Depth, bin	31.50" (80.0 cm)
<b>H1</b> Height	21.25" (54.0 cm)
Service clearanc	12.00" (30.5 cm) top - no front obstructions. 6.00" (15.24 cm) on exhaust side (left, right and rear).
<b>C1</b> Electrical	11 amps, 0.8 kW 115 V/60/1 15 amp circuit 7' (2 m) cord, NEMA 5-15 plug
<b>C2</b> Water inlet	3/8" FPT installation of an in line water filtration system is recommended
<b>C3</b> Drain <sup>1</sup>	3/4" MPT water-cooled models require separate condenser drains
Water-cooled ice machine connections	<b>C4</b> – 3/8" FPT condenser inlet <b>C5</b> – 3/8" FPT condenser drain
Air temperature	50 - 100 F (10 - 38 C)
Water temperature	45 - 90 F (7 - 32 C)
Potable water pressure	10 - 70 psi (69 - 483 kPa)
Condenser water pressure	10 - 125 psi (69 - 861 kPa)
Chewblet ice production at 70 F (21 C) air, 50 F (10 C) water	air-cooled models – 425 lb (193.0 kg) water-cooled models – 443 lb (201.1 kg)
Chewblet ice production at 90 F (32 C) air, 70 F (21 C) water	air-cooled models – 325 lb (147.6 kg) water-cooled models – 372 lb (169.0 kg)
Flake ice production at 90 F (32 C) air, 70 F (21 C) water	water-cooled models – 515 lb (234 kg)
Chewblet energy consumption 90 F (32 C) air, 70 F (21 C) water	air-cooled models – 5.4 kWh water-cooled models – 5.0 kWh per 100 lb (45 kg) ice
Flake energy consumption 90 F (32 C) air, 70 F (21 C) water	water-cooled models – 6.2 kWh per 100 lb (45 kg) ice
Heat rejection	air-cooled models – 5,000 BTU/hr water-cooled models – 1,400 BTU/hr to air, 3,600 BTU/hr to water
Water consumption	12.0 gal (45.4 L) of potable water per 100 lb (45.4 kg) of ice
Water flow requirement for water-cooled condensers	0.25 gpm at 50 F (10 C) 0.5 gpm at 70 F (21 C) 1.25 gpm at 90 F (32 C)
Approximate net weight	150 lb (68 kg)
Approximate ship weight	160 lb (73 kg)

NOTE: For indoor use only

SHORT FORM SPECIFICATION: Ice machine to be Follett model number \_\_\_\_\_. Ice machine to be \_\_\_\_\_air- or \_\_\_\_\_water-cooled. Ice machine production to be approximately 425 lb (193.0 kg) per day of \_\_\_\_\_ Chewblet ice or \_\_\_\_\_flake ice. Ice machine to use environmentally responsible R404a refrigerant. Ice machine to have stainless steel evaporator, auger and top bearings, heavy-duty tapered roller bearings, and low water safety circuit. NSF and ETL listed.

## Configure your ice machine with the following slope front bin models

Model <sup>1</sup>	Maximum bin capacity lb (kg)	Cubic volume cu ft (m)	Width - <b>W2</b> in (cm)	Depth - <b>D3</b> in (cm)	Height - <b>H2</b> in (cm)	Door sill height - <b>H3</b> in (cm)	Required door access in (cm)	Approx. ship weight lb (kg)
300-22 <sup>2</sup>	300 (136)	9.6 (0.27)	22.00 (55.9)	29.50 (74.9)	40.00 (101.6)	26.00 (66.0)	23.00 (58.4)	128 (58)
425-30	430 (195)	13.8 (0.39)	30.00 (76.2)	29.50 (74.9)	40.00 (101.6)	26.00 (66.0)	31.00 (78.7)	144 (65)
650-44	660 (299)	20.8 (0.59)	44.00 (111.8)	29.50 (74.9)	40.00 (101.6)	26.00 (66.0)	32.00 (81.3)	178 (81)
950-48	950 (431)	30.1 (0.85)	48.00 (121.9)	28.25 (71.8)	50.00 (127.0)	36.00 (91.4)	32.00 (81.3)	207 (94)
1025-52	1030 (468)	32.6 (0.92)	52.00 (132.1)	28.25 (71.8)	50.00 (127.0)	36.00 (91.4)	32.00 (81.3)	217 (98)

<sup>1</sup> Follett recommends installation of floor drain with grate with all ice storage bins.

<sup>2</sup> Model 300-22 only for use with Follett Maestro Plus 425, air-cooled, ice machines.

## Dimensional drawing

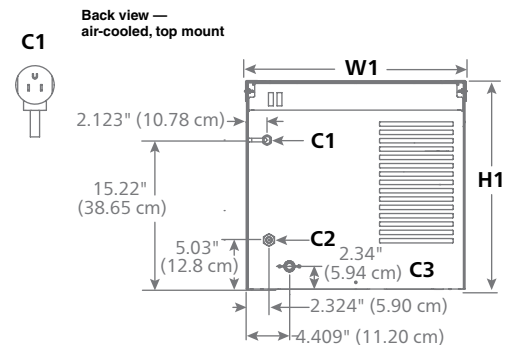
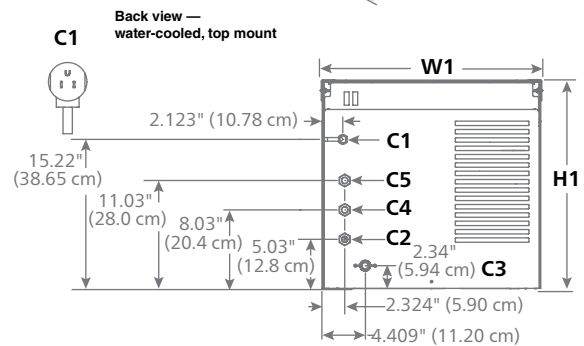
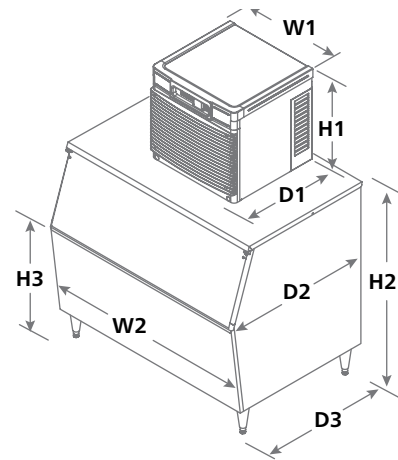

## Accessories

SafeCLEAN Plus™ ice machine cleaner

- 1 x 8 oz (237 ml) bottle (item# 01147826)
- 6 x 8 oz (237 ml) bottles (item# 01149954)
- Carton of 24 x 8 oz (237 ml) bottles (item# 01149962)

Nu-Calgon IMS-III sanitizer, 16 oz bottle (item# 00979674)

Water filters (refer to form# 9905 and 8320)

Additional Maestro Plus accessories (refer to price list)

## Specification for ice and beverage dispenser top mount ice machines

<b>W1</b> Width	22.70" (57.6 cm) fits on 22.00" wide dispensers
<b>D1</b> Depth	24.25" (61.6 cm)
<b>H1</b> Height	21.25" (54.0 cm)
Service clearance	12.00" (30.5 cm) top - no front obstructions. 6.00" (15.24 cm) on exhaust side (left, right and rear).
<b>C1</b> Electrical	11 amps, 0.8 kW 15 amp circuit 7' (2 m) cord, NEMA 5-15 plug
<b>C2</b> Water inlet	3/8" FPT, installation of an in line water filtration system is recommended
<b>C3</b> Drain	3/4" MPT water-cooled models require separate condenser drains
Water-cooled ice machine connections	<b>C4</b> – 3/8" FPT condenser inlet <b>C5</b> – 3/8" FPT condenser drain
Air temperature	50 -100 F (10 - 38 C)
Water temperature	45 - 90 F (7 - 32 C)
Potable water pressure	10 - 70 psi (69 - 483 kPa)
Condenser water pressure	10 - 125 psi (861 kPa)
Ice production at 70 F (21 C) air, 50 F (10 C) water	air-cooled models – 425 lb (193.0 kg) water-cooled models – 443 lb (201.1 kg)
Ice production at 90 F (32 C) air, 70 F (21 C) water	air-cooled models – 325 lb (147.6 kg) water-cooled models – 372 lb (169.0 kg)
Energy consumption 90 F (32 C) air; 70 F (21 C) water	air-cooled models – 5.4 kWh water-cooled models - 5.0 kWh per 100 lb (45.4 kg) ice
Heat rejection	air-cooled models – 5,000 BTU/hr water-cooled models – 1,400 BTU/hr to air, 3,600 BTU/hr to water
Water consumption	12.0 gal (45.4 L) of potable water per 100 lb (45.4 kg) of ice
Water flow requirement for water-cooled condensers	0.25 gpm at 50 F (10 C) 0.5 gpm at 70 F (21 C) 1.25 gpm at 90 F (32 C)
Approximate net weight	150 lb (68 kg)
Approximate ship weight	160 lb (73 kg)
NOTE: For indoor use only	

SHORT FORM SPECIFICATION: Ice machine to be Follett model number \_\_\_\_\_. Ice machine to be \_\_\_\_\_air- or \_\_\_\_\_water-cooled. Ice machine production to be approximately 425 lb (193.0 kg) per day of Chewblet ice at air temperature of 70 F (21 C), water temperature of 50 F (10 C). Ice machine to use environmentally responsible R404a refrigerant. Ice machine to have stainless steel evaporator, auger and top bearings, heavy-duty tapered roller bearing, and low-water safety circuit. NSF and ETL listed.

## Dimensional drawing

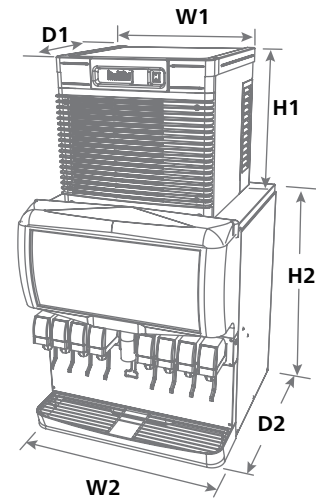

**C1** Back view — air-cooled, top mount

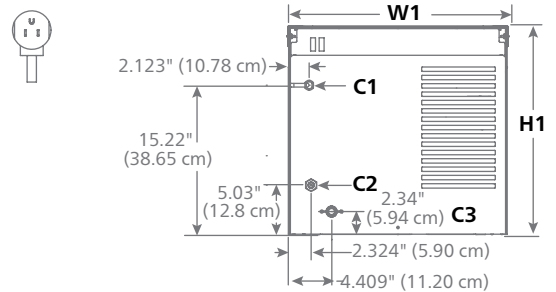

**C1** Back view — water-cooled, top mount

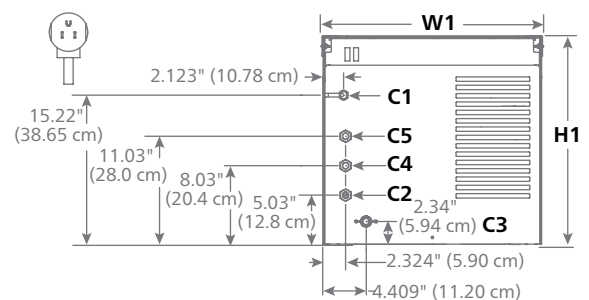

Manufacturer/ Model number	W2 = Width in (cm)	D2 = Depth in (cm)	H2 <sup>1</sup> = Height in (cm)	Harmony top kit
<b>Coca-Cola dispensers</b>				
Freestyle 7000 <sup>2,3</sup>	30.10 (76.5)	33.11 (84.1)	47.00 (119.4)	MTF30SCP
Freestyle 9000 <sup>2</sup>	25.50 (64.8)	35.50 (90.2)	73.75 (187.3)	MTF24SCP
<b>Cornelius dispensers</b>				
DB/DF/ED150 series	22.0 (55.9)	30.0 (76.2)	34.38 ( 87.3)	MTC22SCP
DB/DF/ED175 series	24.5 (62.2)	30.0 (76.2)	34.38 ( 87.4)	MTC24SCP
DB/DF/ED200 series	30.0 (76.2)	30.0 (76.2)	34.38 ( 87.4)	MTC30SCP
DB/DF/ED250 series	30.0 (76.2)	30.0 (76.2)	38.38 ( 97.5)	MTC30SCP
<b>Lancer dispensers</b>				
4500-22N, FS-22N	22.00 (55.9)	30.50 (77.5)	36.50 ( 92.7)	MTL22SCP
4500-30N	30.00 (76.2)	30.50 (77.5)	36.50 ( 92.7)	MTL30SCP
FS-30N	30.00 (76.2)	30.50 (77.5)	42.13 (107.0)	MTL30SCP
Lancer Sensation	30.00 (76.2)	31.00 (78.7)	38.25 ( 97.2)	MTL30SCP
Lancer Touchpoint	32.50 (82.6)	33.70 (85.6)	40.00 (101.6)	MTL30SCP
<b>Pepsi dispensers</b>				
Spire 3.0	27.00 (68.6)	35.00 (88.9)	38.12 ( 96.8)	MTP24SCP
Spire 5.0	30.50 (77.5)	36.00 (91.4)	42.75 (108.6)	MTP30SCP

<sup>1</sup> Net height after installation of top kit.

<sup>2</sup> Consult with Coca-Cola and Follett to qualify application prior to ordering.

<sup>3</sup> Top adapter 46412 and ice kit 46430 must also be ordered from Coca-Cola.

## Chewblet Ice production – air-cooled

Inlet water temperature F (C)	Ambient air temperature F (C)					lb/kg production in 24 hr
	60 (16)	70 (21)	80 (27)	90 (32)	100 (38)	
50 (10)	460 (208)	425 (193)	390 (177)	355 (161)	320 (145)	
60 (16)	438 (198)	405 (184)	373 (169)	340 (154)	308 (139)	
70 (21)	415 (188)	385 (190)	355 (173)	325 (147)	295 (134)	
80 (27)	405 (184)	375 (170)	345 (156)	315 (142)	285 (129)	
90 (32)	395 (179)	365 (166)	335 (152)	305 (138)	275 (125)	

## Chewblet Ice production – water-cooled

Inlet water temperature F (C)	50 (10)	Condenser water temperature F (C)					lb/kg production in 24 hr
		60 (16)	70 (21)	80 (27)	90 (32)	100 (38)	
50 (10)	486 (220)	465 (211)	443 (201)	422 (191)	400 (181)	389 (176)	
60 (16)	464 (210)	445 (202)	425 (193)	406 (184)	386 (175)	367 (166)	
70 (21)	443 (201)	425 (193)	408 (185)	390 (177)	372 (169)	358 (162)	
80 (27)	422 (191)	406 (184)	389 (176)	373 (169)	356 (161)	340 (154)	
90 (32)	400 (181)	385 (175)	371 (168)	356 (161)	341 (155)	326 (148)	

ENERGY STAR and the ENERGY STAR mark are registered trademarks owned by the U.S. Environmental Protection Agency.

FOLLETT HEALTHCARE, HARMONY, MAESTRO PLUS and SAFECLEAN PLUS are trademarks of Follett LLC.

CHEWBLET and FOLLETT are registered trademarks of Follett LLC, registered in the US.

Follett reserves the right to change specifications at any time without obligation. Certifications may vary depending on country of origin.

Maestro Plus top mount healthcare