

CVU155N Series – 220V 60Hz Ice and Water Dispensers

Order parts online
www.follettice.com

Installation, Operation and Service Manual

Service numbers above B50000

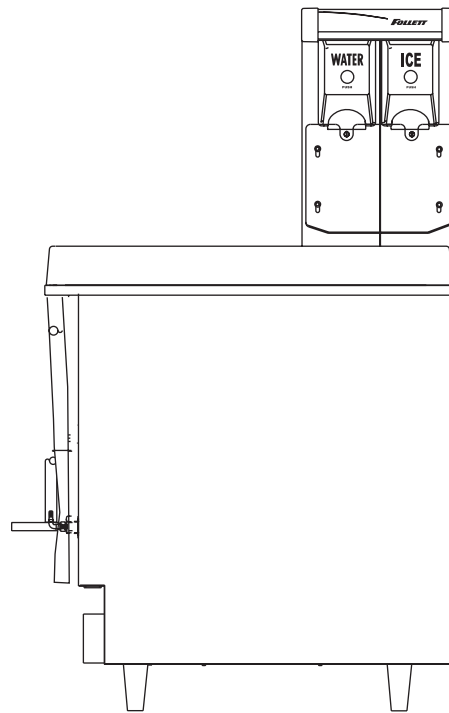

**Following installation, please forward this manual
to the appropriate operations person.**

Table of contents

Welcome to Follett Corporation	3
Important cautions	3
Specifications	4
Installation	6
Installing dispenser in counter	6
Field wiring diagrams	7
Installing optional ice machine	7
Operation	8
How the dispenser works	8
Cleaning	8
Service	10
Dispense chute cover removal	10
Auger motor assembly removal	10
Gate assembly removal	10
Auger and auger tube removal	10
Dispenser wheel removal	10
Wiring diagrams	12
Troubleshooting	13
Replacement parts	14

Welcome to Follett

Follett ice dispensers enjoy a well-deserved reputation for excellent performance, long-term reliability and outstanding after-the-sale support. To ensure that this dispenser delivers that same degree of service, we ask that you take a moment to review this manual before beginning the installation of the dispenser. Should you have any questions or require technical help at any point, please call our technical service group at (610) 252-7301.

Before you begin

After uncrating and removing all packing material, inspect the equipment for concealed shipping damage. If damage is found, notify the shipper immediately and contact Follett Corporation so that we can help in the filing of a claim, if necessary.

Check your paperwork to determine which model you have. Follett model numbers are designed to provide information about the type and capacity of Follett ice dispensing equipment. Following is an explanation of the different model numbers in the CVU155 series.

CVU155N0LP

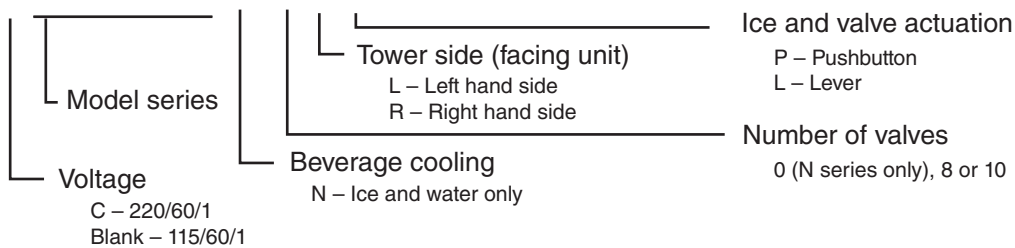

Important cautions

For indoor use only.

Storage area of dispenser contains mechanical, moving parts. Keep hands and arms clear of this area at all times. If access to this area is required, power to unit must be disconnected first.

Ice is slippery. Maintain counters and floors around dispenser in a clean and ice-free condition.

Ice is food. Follow recommended cleaning instructions to maintain cleanliness of delivered ice.

Always disconnect power before cleaning or servicing the dispenser.

Failure to remove all sanitizer may result in health hazard.

Follett manual load dispensers can accommodate most cube/cubelet ices up to 1" square, or Follett compressed nugget ice. Crushed, flake, bagged, nugget or congealed ice cannot be used. Use of these ices can jam dispenser and void warranty. Separate any "waffle-like" sections of cubes before adding to dispenser. For ice compatibility questions, please call Follett customer service at (610) 252-7301.

Specifications

Electrical

Each ice machine and dispenser require a separate circuit with electrical disconnect within 6 m (10 ft). Equipment ground required. Standard electrical – 220V, 60Hz, 1 phase.

Model number	Ice machine amperage	Dispenser amperage
CVU155N series	5.0 amps ea	2.0 amps

Plumbing

Dispenser 3/4" PVC pipe nipple for bin drain
 3/4" PVC pipe nipple for drain pan drain
 3/8" ID red line tubing for water in

Ice machine Refer to detailed specifications in ice machine installation manual packed with ice machine

Dimensions and clearances

Required clearances

- 1295 mm (51") minimum above counter for installation if dispenser will be dropped into counter
- 915 mm (36") minimum above counter for all units after installation for auger cleaning and servicing
- 305 mm (12") minimum on side opposite ice chute for service
- 305 mm (12") minimum on ice chute side if ice transport tube enters this side
- 305 mm (12") minimum between dispenser side(s) and optional ice machine(s)

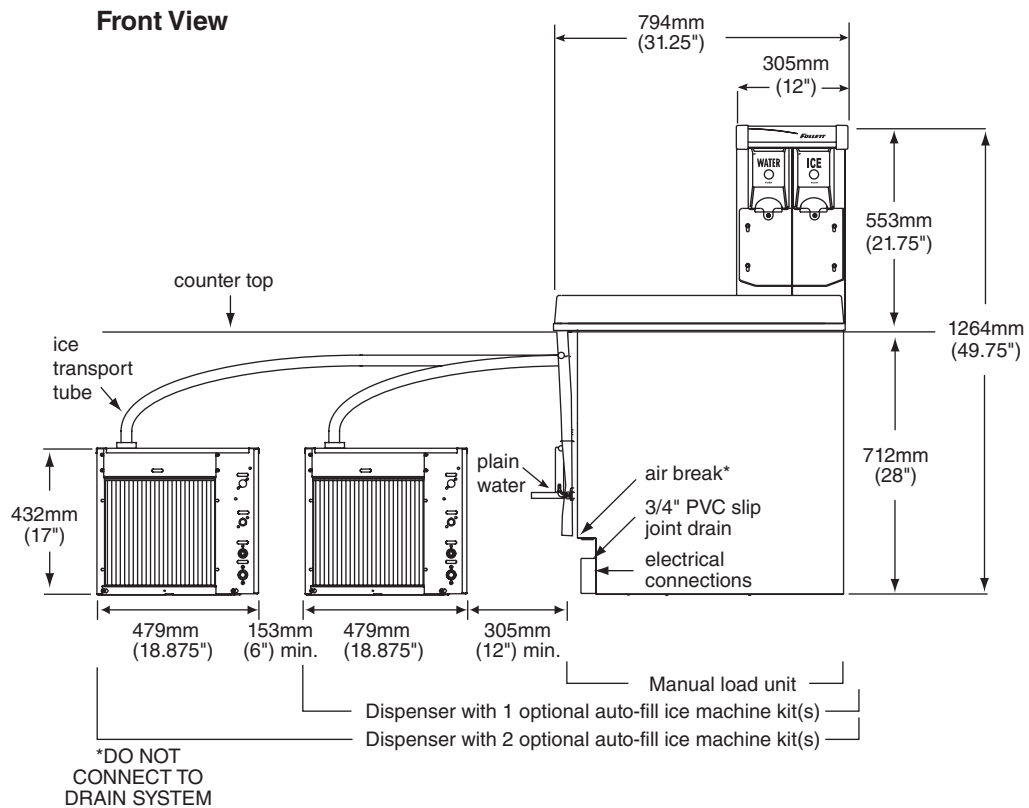
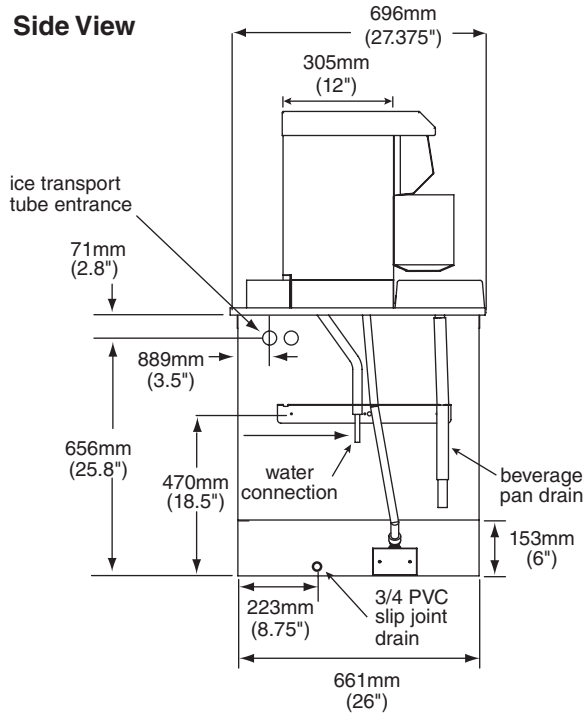

Installation

Installing dispenser in counter

Note: All dispensers must be supported from below with supplied 153 – 229 mm (6" – 9") adjustable leg accessory, or equivalent. Do not hang dispenser on flange.

All dispensers must be installed level in both directions to ensure proper operation.

1. Check that dispenser location meets all requirements in this manual and cut counter as shown.

**Plan View
counter cut-out**

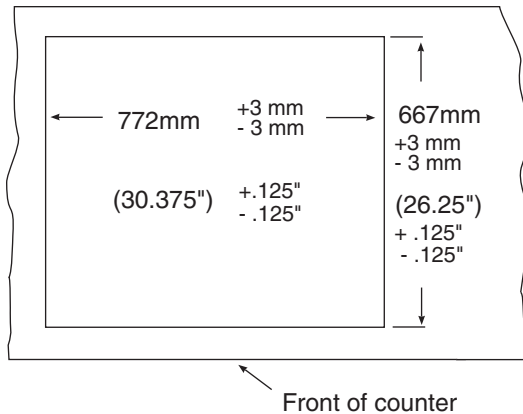

2. Place support blocks in cabinet to raise dispenser to a height of 305 mm (12").
 3. Place dispenser in counter onto support blocks.
 4. Attach adjustable legs to dispenser.
 5. Remove support blocks and lower dispenser feet to floor.
 6. Adjust legs for 4 mm (1/8") clearance between dispenser lip and countertop to verify there is no load on flange.
 7. Apply a bead approximately 6 mm (1/4") in diameter of NSF-listed silicone sealant (Dow Corning RTV-732 or equivalent) around perimeter of dispenser where it meets counter. Smooth sealant to a 4 mm (1/8") radius.
 8. Install a PVC drain line with at least a 20 mm per 1 m (1/4" per foot) slope. Insulate drain line to prevent condensation.
- Note:** Do not apply excessive heat if any sweating of fittings is necessary. Heat conduction through metal may melt threads in plastic drain.
Do not reduce drain line size or tie drains together.
9. Make electrical connections in accordance with applicable wiring diagrams provided. Provide disconnects within 3 m (10 ft) of dispenser and ice machine for servicing.

Field wiring diagrams

Note: Field wiring diagrams are intended to aid electricians or technicians in understanding how equipment works. All field wiring must be installed in accordance with all local and NEC codes.

If attaching optional Chewblet® MCC400AVS auto-fill ice machine kit(s)

IMPORTANT

Field wiring diagram is intended to aid electrician or technician in understanding how equipment works.

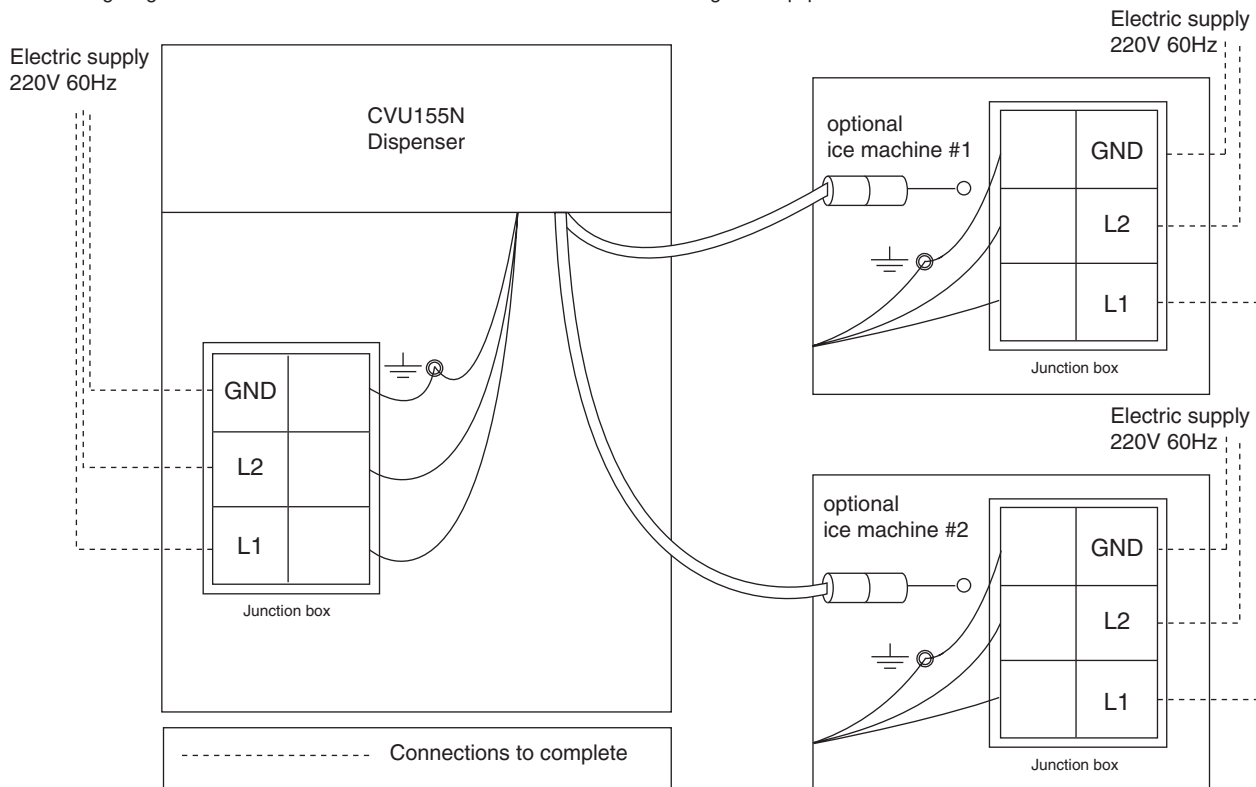

Installing optional auto-fill ice machine kit(s)

Correct installation of RIDE™ model ice machine(s) is critical to proper performance of ice machine. Refer to installation manual packed with ice machine for important details on ice transport tube run, ventilation requirements and other installation requirements. Failure to comply with instructions may void warranty.

To start and operate dispenser

1. Follow detailed cleaning instructions in service manual before operating dispenser.
2. For manual load units, remove front drain pan or rear lid and fill storage area with approved ice.

Note: Follett manual load dispensers can accommodate most cube/cubelet ices up to 1" square, or Follett compressed nugget ice. Crushed, flake, bagged, nugget or congealed ice cannot be used. Use of these ices can jam dispenser and void warranty. Separate any "waffle-like" sections of cubes before adding to dispenser. For ice compatibility questions, please call Follett customer service at (610) 252-7301.

3. Turn power switch located on dispenser control box to ON position.
4. For automatic fill units, follow detailed instructions in ice machine installation section of installation manual, then turn ice machine (bin signal) switch(es) located on dispenser control box to ON position and begin to make ice.
5. When dispenser has at least 153 mm (6") of ice in storage area, test operation.

Operation

How the dispenser works

Follett's dispensers are available in automatic load configurations, fed from one or two Follett RIDE model ice machines or manual load configurations (using ice from another source).

In all models, ice is stored below the counter in the dispenser storage area. When the dispense lever or button is pushed, the dispense motors are activated. This causes the wheel assembly in the storage area to turn, moving ice to the vertical auger assembly, which carries ice up to the dispense chute where it drops by gravity into the container.

In automatic load units, ice is manufactured in either one or two Follett RIDE model ice machines. These ice machines may be located up to 6 m (20 ft) away from the dispenser. Extruded ice is transported through a tube and pushed to the storage compartment of the dispenser. When the bin is filled, a bin thermostat shuts the ice machine off to avoid overfilling of the bin. The ice machine will restart after 20 minutes if the bin is calling for ice.

Ice movement

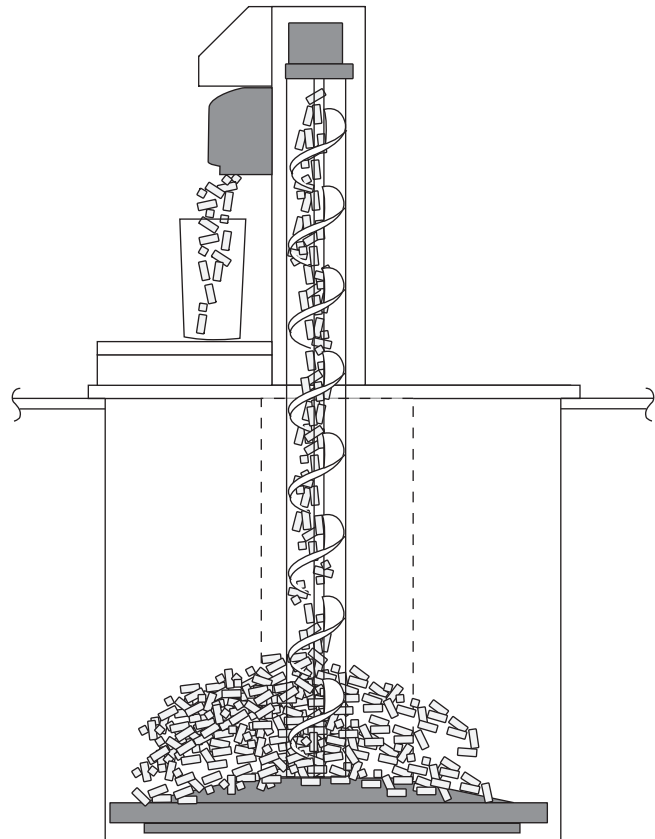

Cleaning

Using solutions below, clean and sanitize storage area and beverage lines before starting unit and on a routine basis as noted below.

Note: Always disconnect power before cleaning dispenser.

Do not run plastic parts through a dishwasher.

Solution A: Combine 30 ml (1 oz) bleach with 8 L (2 gal) hot water.

Solution B: Combine 7 ml (1/4 oz) bleach with 8 L (2 gal) hot water.

Note: Cleaning solutions temperature must be at 24 to 52 C (75 – 125 F)

Recommended cleaning prior to start up

Cleaning ice storage area before use

1. Refer to disassembly instructions (see Service section) and remove dispense wheel from ice storage area.
2. Remove auger, auger tube and dispense mechanism.
3. Wipe all components and ice storage area with cleaning Solution A.
4. Rinse all components and ice storage area thoroughly with clear, potable water.
5. Wipe all components and ice storage area with sanitizing Solution B.

Recommended daily dispenser cleaning

1. Remove all debris from drain pan.
2. Pour 4 L (1 gallon) hot water into drain pan to keep drain lines clear.

Recommended weekly dispenser cleaning

1. Remove drain pan and grille and wash with Solution A. Rinse thoroughly.
2. Pour a solution of 237 ml/8 oz (1 cup) household bleach mixed with 3.8 L (1 gallon) hot water into drain pan to help prevent algae growth in drain lines.

Recommended quarterly dispenser cleaning

1. Remove top from dispenser and turn power switch to OFF position.
2. Remove ice from storage area.
3. Remove dispense chute cover, chute, auger motor assembly, auger and auger tube (see Service section).
4. Remove drain pan, grille and dispense wheel (see Service section).
5. Clean all components and bin storage area with Solution A, rinse thoroughly with clear water and sanitize with Solution B.

Putting unit back in service after quarterly cleaning

1. Reassemble components.
2. For manual load units, fill unit with an approved ice (see important cautions on page 4).
3. For automatic load units with MCC400A/W (R404A refrigerant) ice machines, turn bin signal switch(es) and dispenser power switch to ON position and allow storage area to fill.
4. Dispense and discard all ice, verifying dispenser is functioning properly.

Recommended quarterly cleaning of optional ice machine.

Units equipped with optional ice machines require cleaning of ice machine system at least every six months, and more often if local water conditions dictate. Failure to clean ice machine system will result in decreased performance and potential damage to ice machine. Refer to Ice machine Installation, Operation and Service Manual.

Service

Dispense chute cover removal

1. Remove top cover.
2. Push chute cover up vertically to slip off holding tab.
3. After clearing tab, pull chute cover forward to remove.

Dispense mechanism assembly removal

1. Remove top cover.
2. Remove chute cover (see above).
3. Remove auger motor assembly (see above).
4. Remove quick release pins from the ice chutes and gates, then unplug wires from solenoids.
5. Lift dispense mechanism up and off auger tube.

Auger and auger tube removal (Fig. 3)

1. Remove auger motor and dispense mechanism assembly (see above).
2. Pull auger upward to clear auger tube.
3. Lift auger tube upward to clear dispenser top.
4. Slide tube and bearing plate through auger tube gasket.

Dispense wheel removal

1. Remove drain pan assembly and bin access cover.
2. Remove center thumbnut and threaded rod on dispense wheel assembly and lift wheel out front access opening.

Auger motor assembly removal

1. Remove top cover.
2. Remove one thumbnut on rear of motor bracket.
3. Lift motor bracket up and unplug electric quick disconnects.
4. Remove motor assembly.

Dispense wheel motor removal (Fig. 3)

1. Remove drain pan, bin access cover and dispense wheel.
2. Remove stainless steel baffle plate under dispense wheel.
3. Remove two screws holding wheel motor bracket on bin.
4. Lift plate and motor up.
5. Unplug electric quick disconnects from motor.
6. Lift motor and mounting plate out front access opening.

Fig. 1

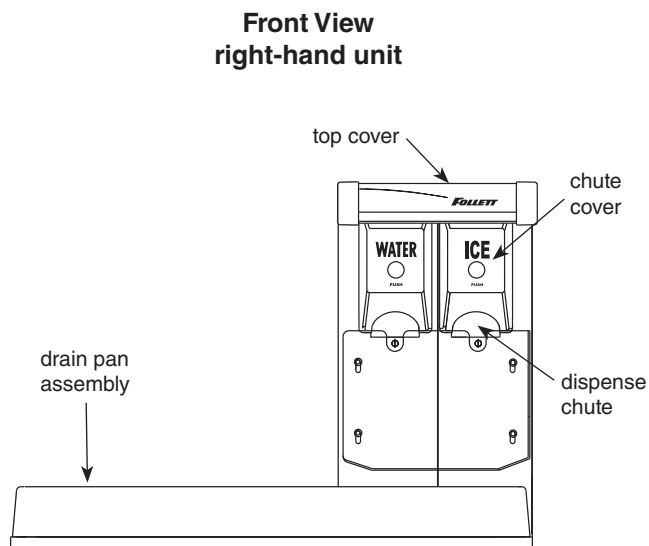

Fig. 2

**Dispense assembly, Top View
right-hand unit**

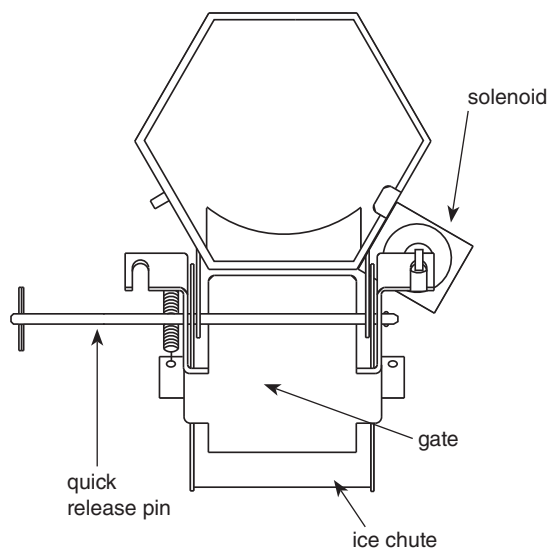
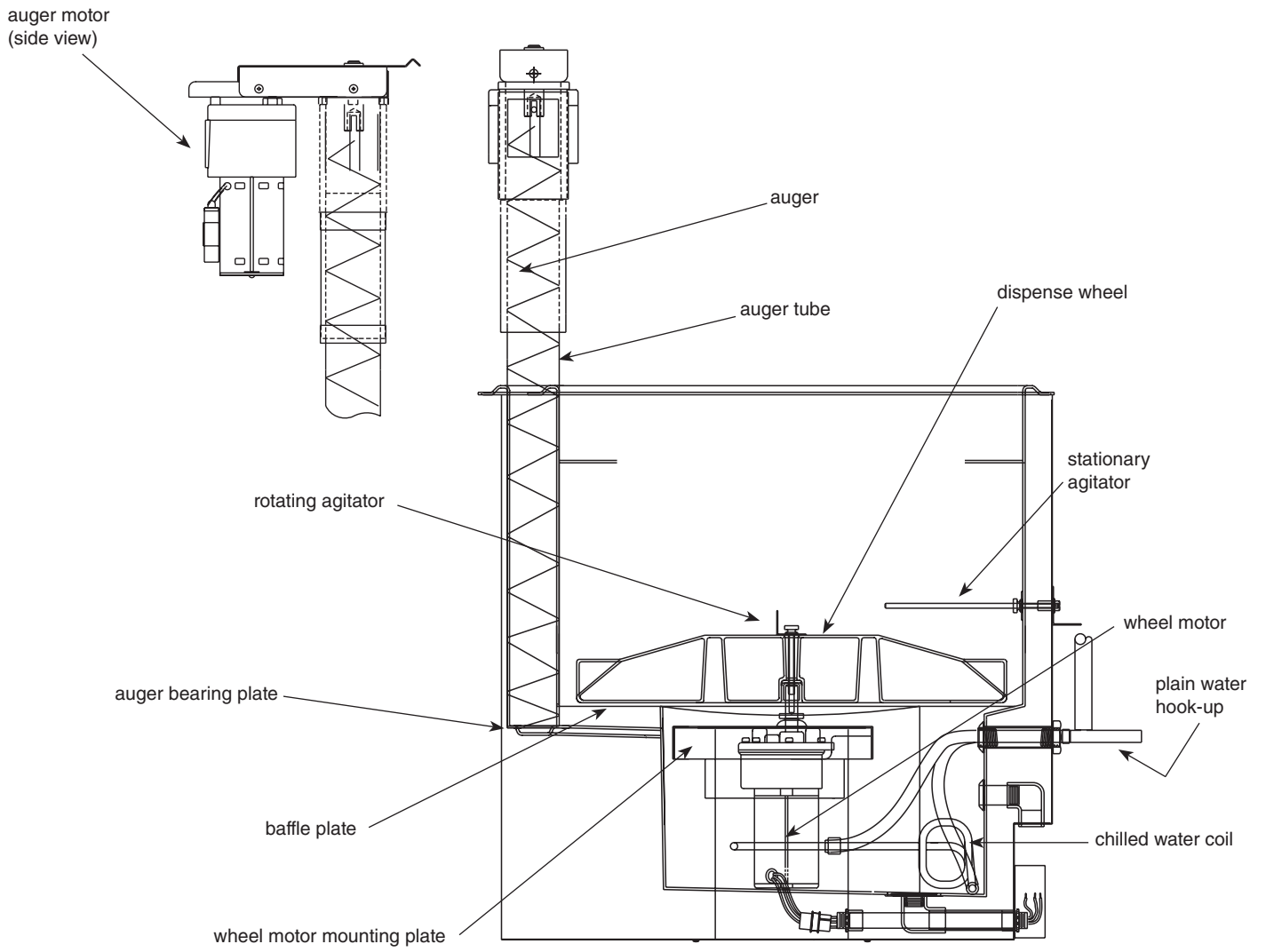
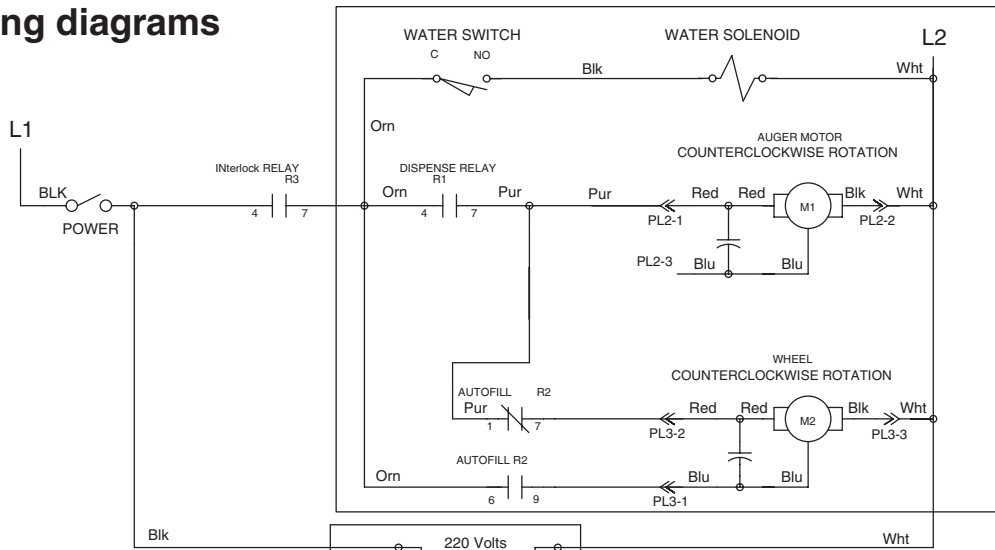

Fig. 3

Front View



Wiring diagrams



right-hand dispenser

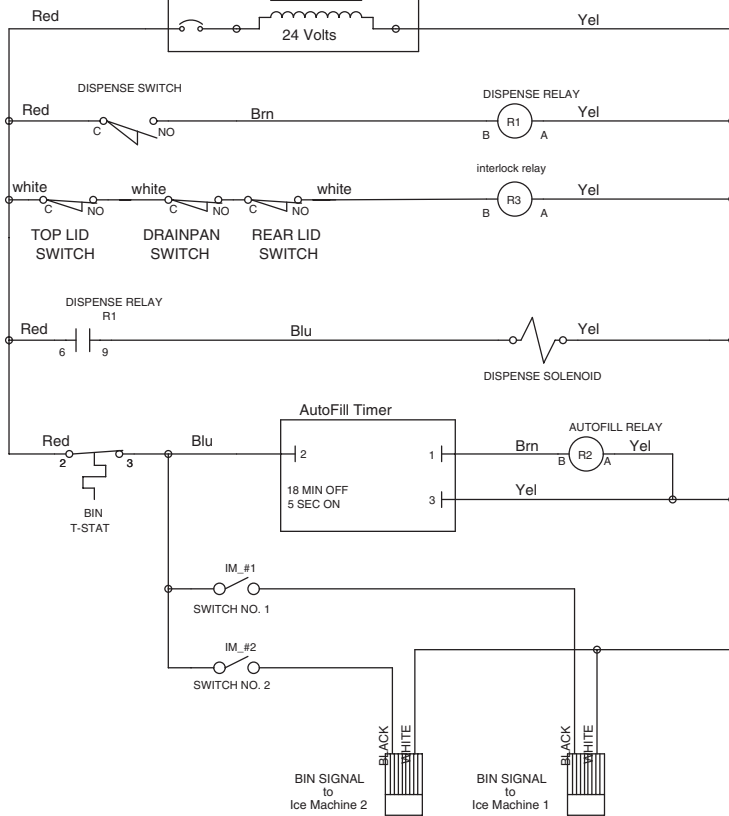

right or left-hand dispenser

left-hand dispenser

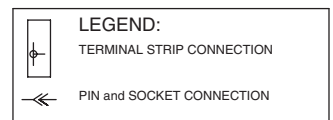
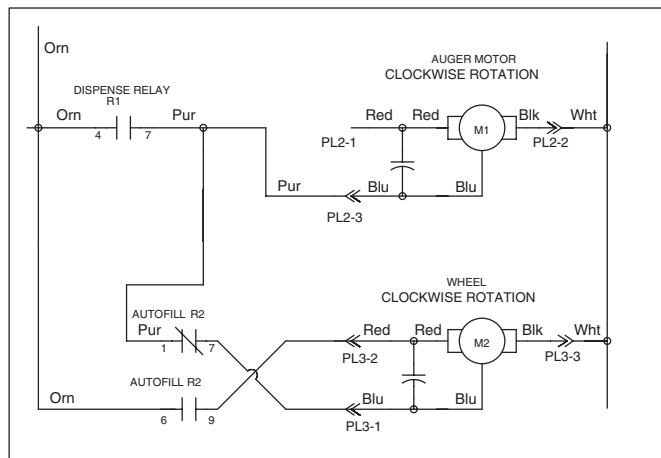

Dispenser troubleshooting guide

Before calling for service

1. Check that ice is in the dispenser and that congealed cubes are not causing a jam.
2. Check that circuit breaker and switches are in ON position.
3. Check that drain pan, rear lid and top are on securely. If ajar, dispenser will not operate. When the top is off, auger does not operate, even though the solenoids do.
4. Check that all drains are clear.

Note: For units equipped with Follett Chewblet ice machine, see Ice machine Operation and Service Manual for service and troubleshooting information.

Symptom	Possible cause	Solution
Ice does not dispense. • Auger motor does not run • Wheel motor does not run	1. Power switch faulty or in OFF position; loose connection. 2. Faulty dispense switch. 3. Faulty transformer. 4. Drain pan ajar. 5. Faulty drain pan safety switch.	1. Turn power switch to ON position; check connections. 2. Replace switch. 3. Replace transformer. 4. Check pan and reseal. 5. Replace switch.
Ice does not dispense. • Auger motor runs • Wheel motor runs • Gate does not open	1. Loose electrical connection. 2. Linkage problem between solenoid and gate. 3. Faulty solenoid.	1. Check connections. 2. Check linkage. 3. Replace solenoid.
Ice does not dispense. • Auger motor does not run • Wheel motor runs	1. Loose electrical connection. 2. Faulty auger motor. 3. Faulty run capacitor.	1. Check connections. 2. Check auger motor. 3. Check run capacitor.
Ice does not dispense. • Auger motor runs • Wheel motor does not run	1. Loose electrical connection. 2. Faulty wheel motor. 3. Faulty run capacitor.	1. Check connections. 2. Check wheel motor. 3. Check capacitor.
No ice in dispenser.	1. Power switch in OFF position or faulty. 2. Bin signal switches in OFF position or faulty. 3. Faulty bin thermostat. 4. Faulty transformer. 5. Ice machine related problem. 6. Faulty run capacitor.	1. Check switch and replace if necessary. 2. Check switch and replace if necessary. 3. Replace bin thermostat. 4. Replace transformer. 5. Refer to ice machine Operation and Service Manual for diagnosing. 6. Check for power and bin signal on ice machine PC board.

If problems persist after following this basic troubleshooting guide, call Follett's technical service department at (877) 612-5086 or +1 (610) 252-7301.

Replacement parts

Dispenser exterior

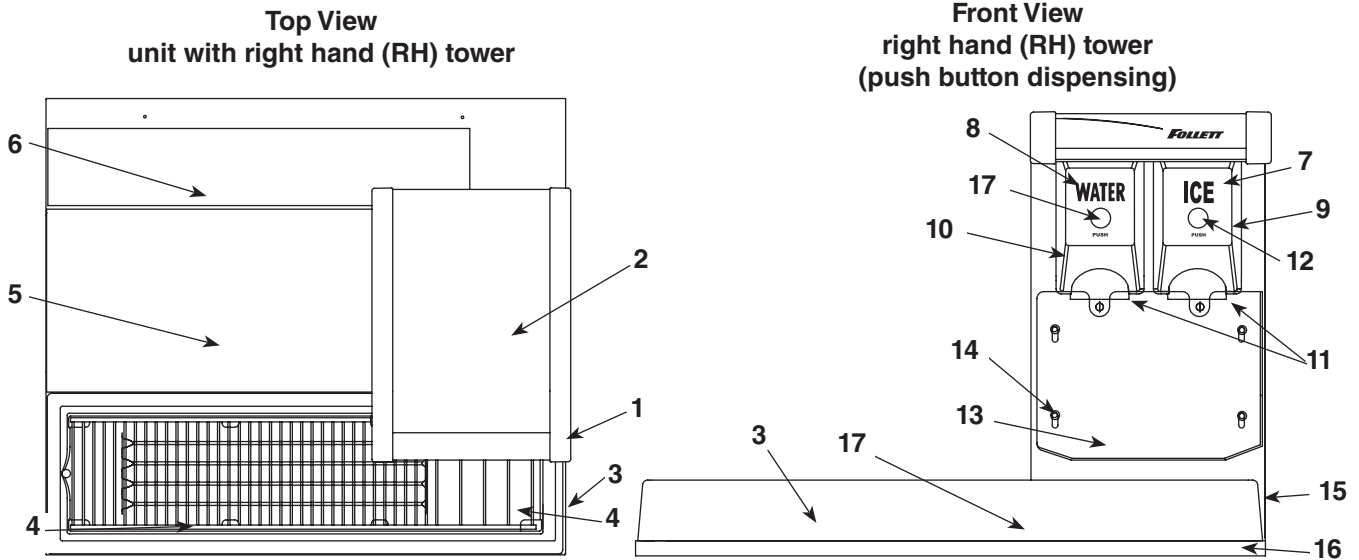

Reference # Part #	Description	
Label, "Follett"	502438	1
2	Top cover (includes label and magnet)	502905
3	Drain pan (includes magnet)	502903
4	Grille, drain pan	502450
5	Cover, electrical components	502902
6	Lid, rear access (includes magnet)	502904
Not shown	Cover, ice storage (under drain pan)	502453
7	Label, ice, dispense cover, push button	502623
8	Label, water, dispense cover, push button	502617
9	Cover, dispense chute, black push button (includes button and label), ice	502440
9	Cover, dispense chute, push button, ice (includes stainless steel switch and label)	01156470
10	Cover, dispense chute, black push button (includes button and label), water	502620
10	Cover, dispense chute, push button, water (includes stainless steel switch and label)	01145481
11	Chute, focus, clear plastic	502459
Not shown	Push pin, clear chute	502618
12	Switch, black push button, for ice (includes label)	502441
12	Switch, stainless steel push button, for ice (includes label)	01145507
13	Splash shield, right hand unit	502612
Not shown	Splash shield, left hand unit	502613
14	Thumbscrew, splash shield, 10-32 x 1/2"	501100
Not shown	Panel, access, right hand and left hand units	502907
16	Panel, wrap, right hand unit	502909
Not shown	Panel, wrap, left hand unit	502908
Not shown	Panel, rear, motor support, right hand unit	502586
Not shown	Panel, rear, motor support, left hand unit	502587
Not shown	Clip, Tinnerman, 10-32	502621
Not shown	Screw, 10-32 x 1/2"	502287
Not shown	Legs, 153 mm adjustable to 229 mm, set of 4	502454
17	Switch, water dispense, black push button (includes label)	502648
17	Switch, water dispense, stainless steel push button (includes label)	01145473
Not shown	Plug 2 lead, male	502333
Not shown	Plug 2 lead, female	502334

Dispense assembly

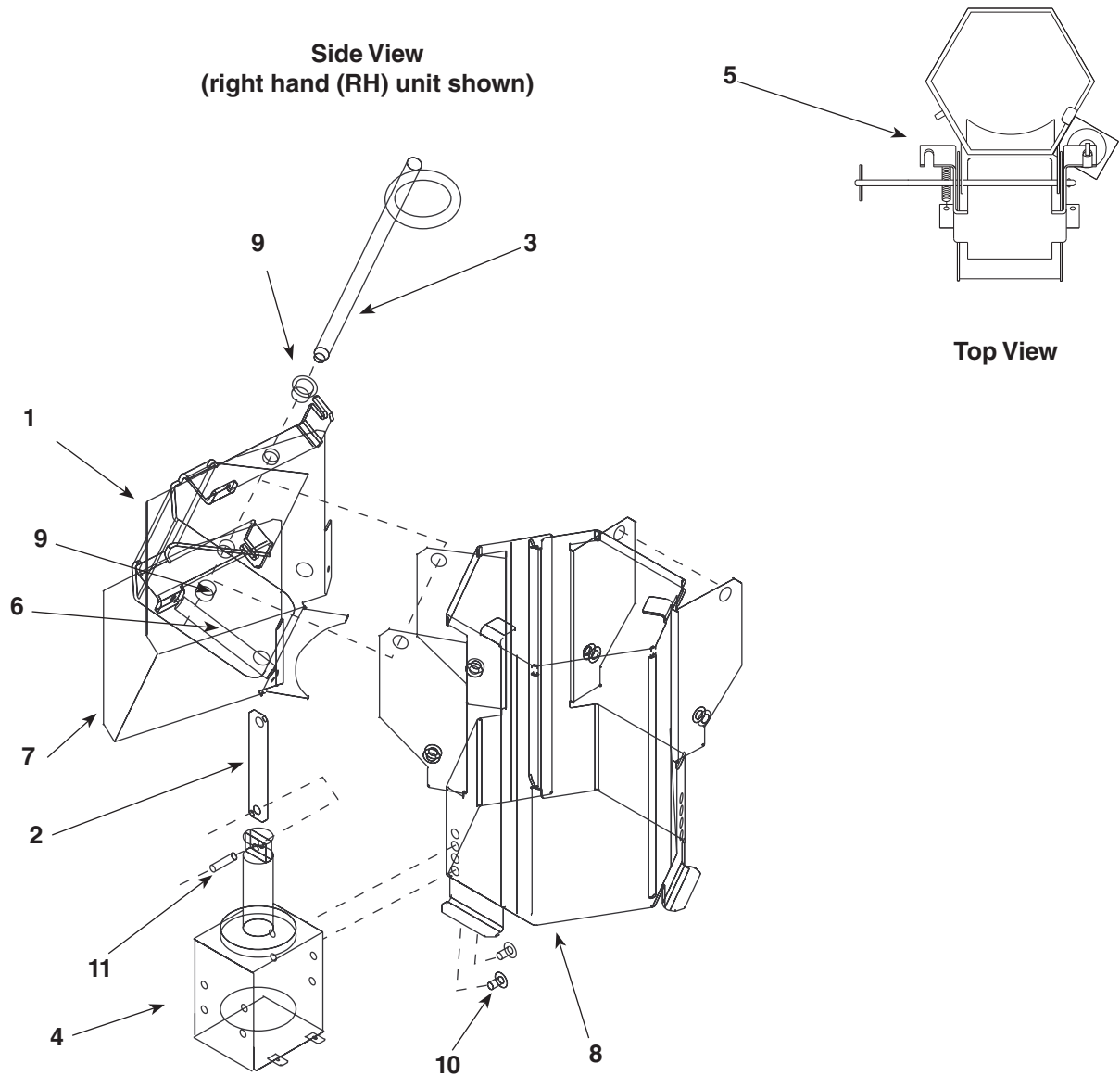

Reference #	Description	Part #
1	Gate, dispense	502455
2	Linkage pin, gate/solenoid	502456
3	Pin, quick release, 141 mm, dispense gate	502102
4	Solenoid (includes linkage pin)	00126607
5	Dispense mechanism assembly, right hand unit	502458
Not shown	Dispense mechanism assembly, left hand unit	502496
6	Spring, dispense mechanism (1 per side)	501950
7	Chute, ice	502457
8	Wrap, dispense mechanism	502607
9	Bushing, Ni liners	501249
10	Screw, 8-32 x 5/16"	502625
11	Pin, spring	502624

Hopper

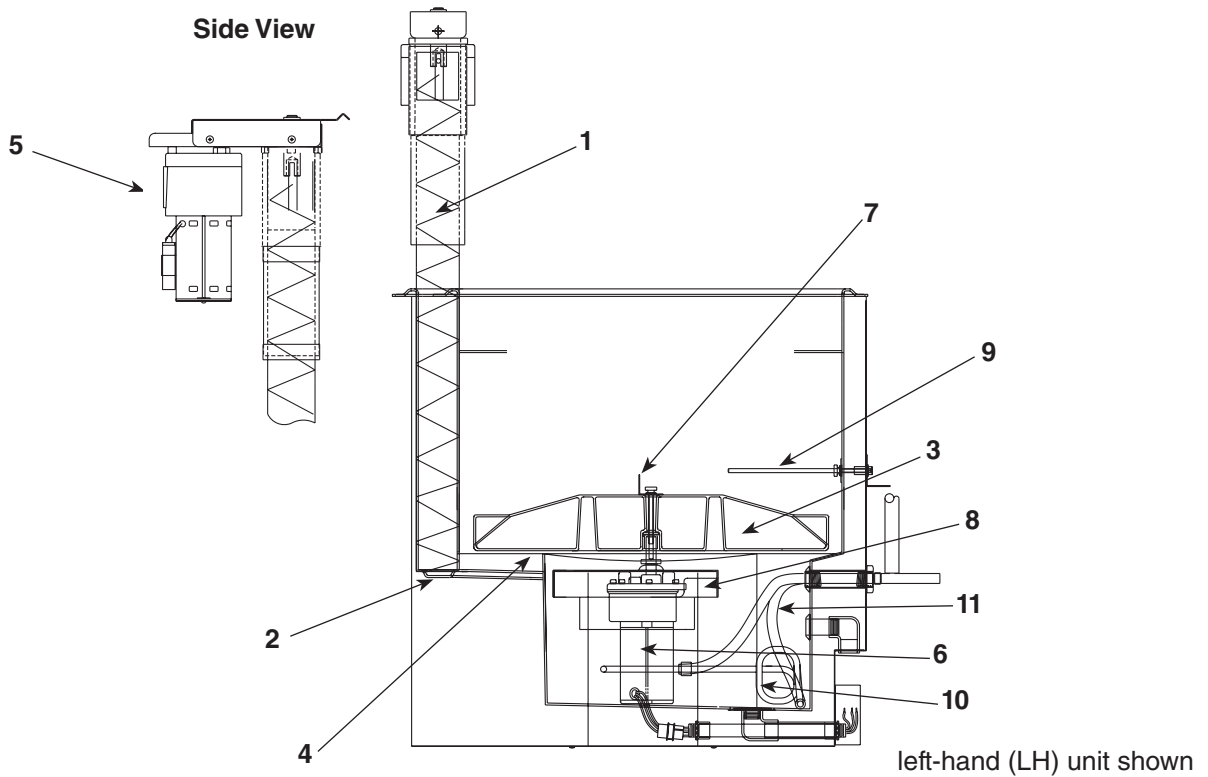

Reference #	Description	Part #
1	Auger, LH unit (black, stamped with "1")	502491
Not shown	Auger, RH unit (gray, stamped with "2")	502492
2	Plate, auger bearing	501696
Not shown	Tube, auger, right hand unit	502487
Not shown	Tube, auger, left hand unit	502488
3	Wheel, dispense (includes stud and rotating agitator)	501681
4	Baffle (under dispense wheel)	501684
Not shown	Drive bar (under dispense wheel)	501682
5	Motor, vertical auger	502889
6	Motor, wheel	502890
Not shown	Seal, wheel motor	501333
Not shown	Spacer, wheel motor	501768
Not shown	Capacitor, wheel motor	502891
7	Agitator, rotating, 534 mm long	502484
8	Plate, wheel motor mounting	502615
9	Agitator, stationery	502490
Not shown	Bracket, ice tube, double tube	502497
Not shown	Ice transport tube (sold by the foot)	500366
Not shown	Ice transport tube, 3 m (10 ft)	502522
Not shown	Ice transport tube, 6 m (20 ft)	502523
Not shown	Insulation, transport tube (sold by the foot)	501176
10	Coil, plain water	502461
11	Tubing, water (sold by the foot)	502356
Not shown	Cover, blank ice entry	502674
Not shown	Gasket, ice entry	502672
Not shown	Plate, ice entry, 2 holes	502673

Auger motor

Side View

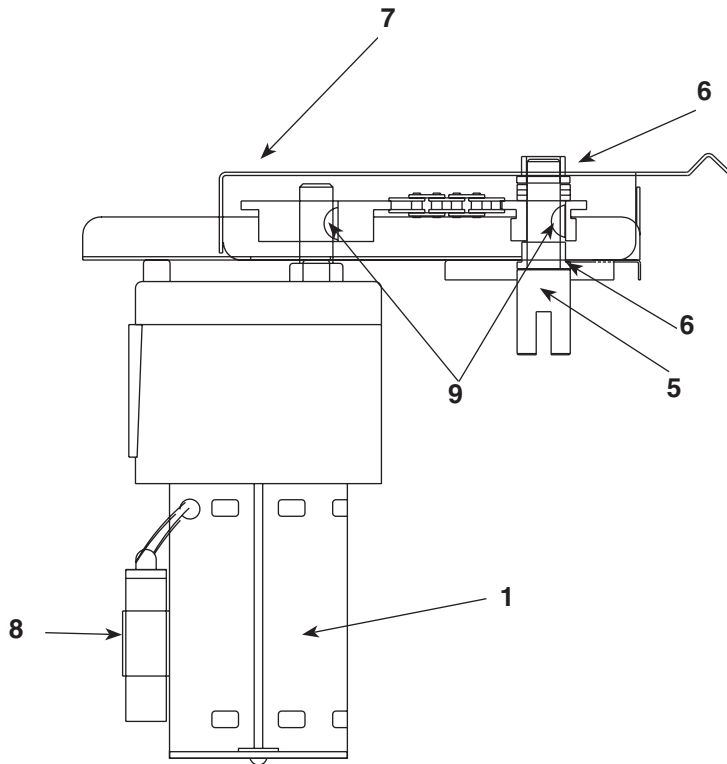

Top View

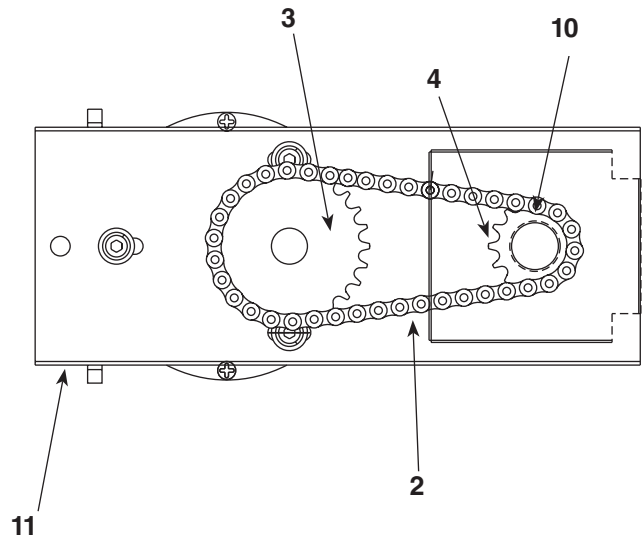

Reference #	Description	Part #
	Auger motor/drive assembly, vertical (includes all items below)	502893
1	Motor, vertical auger (includes gearbox and capacitor)	502889
2	Chain, auger drive #35, 40p	502477
3	Sprocket 35#, 22T 5/8 bore	502478
4	Sprocket 35#, 12T 5/8 bore	502479
5	Drive shaft	502480
6	Bearing, auger, upper and lower	501314
7	Cover and bearing, chain drive (includes 501314)	502912
8	Capacitor, 25 mf, 270 V	502892
9	Key, Woodruff	502482
10	Washers, thrust (4)	501765
11	Mounting plate, auger motor (includes 501314)	502913

Electrical components

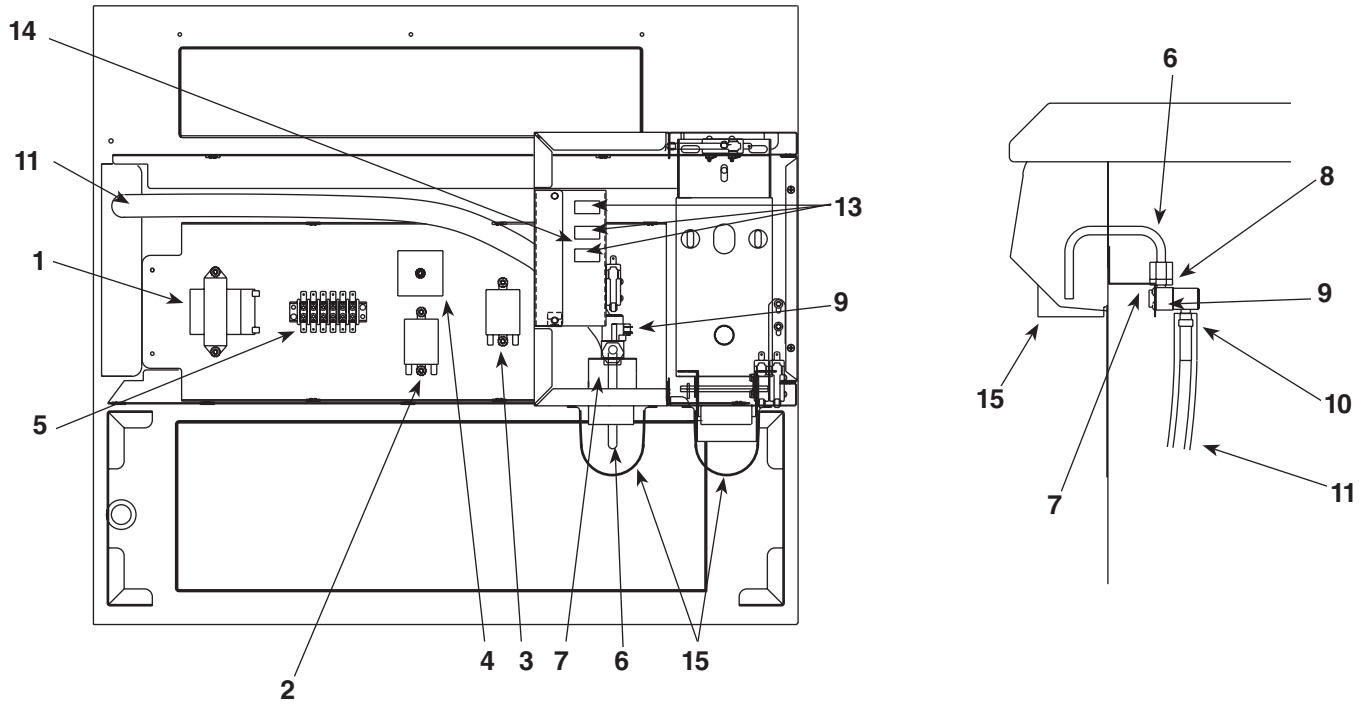

Reference #	Description	Part #
1	Transformer, 24V	502885
2	Relay, dispense	501826
3	Relay, auto fill	501826
4	Timer, auto fill (automatic fill units)	502471
5	Strip, terminal	502472
6	Tube, water dispense, stainless steel	502356
7	Bracket, water solenoid	01111228
8	Fitting, compression to NPT	01111434
	Valve, solenoid, water, complete assembly	01147610
9	Valve, solenoid, water	00116848
10	Fitting, 1/4" barbed, 1/4" push to connect	01111426
11	Tubing, water (sold by the foot)	502356
13	Switches (power and ice machine)	502209
14	Bracket, switch mounting, RH (power and ice machine)	502914
Not shown	Bracket, switch mounting, LH (power and ice machine)	502906
15	Chute, focus, clear plastic	502459
Not shown	Thermostat, bin level	500514
Not shown	Magnetic switch (1) one located under top cover (2) two located under electrical component cover	502887
Not shown	Magnets (2) two located on drain pan (1) one located on top cover (1) one located on rear cover	502888

Rejestracja gwarancji i ocena sprzętu

Dziękujemy za zakup urządzenia firmy Follett. Mamy nadzieję, że nasze urządzenia spełniają i przekraczają Państwa oczekiwania, gdyż naszym celem jest dostarczenie klientom wysoce wartościowych produktów i usług, zasługujących na ich pełne uznanie.

Prosimy zapoznać się z załączoną instrukcją instalacji i obsługi. Istotne jest przeprowadzenie instalacji zgodnie z wymogami producenta, co zapewni działanie urządzenia z maksymalną wydajnością.

Follett LLC nie będzie ponosić odpowiedzialności za szkody wtórne, wydatki, koszty podłączenia lub odłączenia lub jakiegokolwiek straty wynikające z wady urządzenia.

Aby uzyskać szczegółowe informacje na temat warunków gwarancji, prosimy odwiedzić naszą stronę internetową www.follettice.com/productwarranties.

Rejestracja gwarancji i ocena urządzenia to istotne czynności, ułatwiające nam utrzymanie aktualnych danych o miejscach instalacji naszych urządzeń i o ich działaniu. Prosimy o zarejestrowanie gwarancji na nabyte urządzenie firmy Follett na naszej witrynie www.follettice.com/support, gdzie należy wybrać Warranty Registration (Rejestracja gwarancji) i Equipment Evaluation (Ocena urządzenia). Jest to łatwe i nieskomplikowane, prosimy o znalezienie na to paru minut jeszcze dzisiaj. Na formularzu jest również miejsce na przekazanie nam komentarzy i informacji zwrotnych. Proszę podzielić się z nami swoimi wrażeniami, abyśmy mogli wykorzystać je w naszych ciągłych dążeniach do usprawnień.

Jesteśmy dumni z naszych znakomitych urządzeń i staramy się usilnie wspierać je znakomitą obsługą klienta i wsparciem technicznym. Chcielibyśmy wiedzieć, w jaki jeszcze sposób moglibyśmy Państwu pomóc. Z przyjemnością odpowiemy na Państwa pytania.

Registro de Garantía y Evaluación del Equipo

Gracias por haber elegido este producto Follett®. Esperamos que nuestro equipo cumpla o supere sus expectativas porque es nuestro objetivo ofrecer productos y servicios de gran valor que se ganen su plena confianza.

Le rogamos consulte el manual de instalación y de instrucciones adjunto, ya que es muy importante que la instalación se realice según las especificaciones de fábrica para que el equipo funcione a su máxima eficiencia.

Follett LLC no se hace responsable de los daños indirectos, costos, gastos por conexión y desconexión o pérdidas por causa de defecto de la máquina.

Si desea una información más completa sobre la garantía, visite nuestro sitio web www.follettice.com/productwarranties.

Las operaciones de registro de la garantía y evaluación del equipo son importantes para que podamos realizar un seguimiento de nuestro equipo y registrar el rendimiento de la maquinaria. Por favor, registre las garantías del equipo Follett en nuestro sitio web www.follettice.com/support y seleccione Registro de la Garantía y Evaluación del Equipo. Es muy sencillo, solo le llevará un momento realizar hoy mismo el registro. En el formulario incluimos un espacio en blanco para sus comentarios y opiniones. Infórmenos sobre su experiencia para que podamos incorporarla a nuestros continuos esfuerzos de mejora.

Nos enorgullecemos de producir un equipo excepcional y trabajamos duro para respaldarlo con un soporte técnico y un servicio de atención al cliente de primera. Le rogamos nos indique qué más podemos hacer para ayudarlo. Estaremos encantados de responder a sus dudas.

Enregistrement de la garantie et évaluation de l'équipement

Merci d'avoir acheté un équipement Follett®. Notre objectif étant d'offrir des produits et des services de grande valeur vous satisfaisant pleinement, nous espérons que celui-ci satisfera, voire dépassera, vos attentes !

Veuillez consulter le manuel d'installation et d'exploitation. Il est important que l'installation soit réalisée conformément aux spécifications de l'usine, de sorte que votre équipement fonctionne à son rendement maximum.

Follett LLC n'est pas responsable de tout dommage consécutif, de toute dépense, de tout frais de raccordement ou de déconnexion, ni de toute perte liée à un défaut de la machine.

Pour lire la garantie dans son ensemble, visitez notre site Internet www.follettice.com/productwarranties.

L'enregistrement de la garantie et l'évaluation de l'équipement sont importants pour nous aider à suivre notre équipement et pour enregistrer les performances de la machine. Nous vous demandons donc d'enregistrer la garantie de votre équipement Follett sur notre site Internet, www.follettice.com/support, dans la section Warranty Registration and Equipment Evaluation. Cette opération est simple ; veuillez prendre un moment pour la réaliser aujourd'hui.

Le formulaire contient également un espace pour nous faire parvenir vos commentaires et un retour d'informations. Veuillez nous faire part de votre expérience pour que nous puissions prendre appui dessus pour poursuivre nos efforts constants d'amélioration.

Nous sommes fiers de produire des équipements exceptionnels et nous travaillons avec acharnement pour y associer une assistance à la clientèle et technique exceptionnelle. N'hésitez pas à nous indiquer dans quelle mesure nous pouvons vous aider. Nous serions ravis de répondre à vos questions.

Garantieregistrierung und Produktbeurteilung

Vielen Dank, dass Sie sich für ein Follett®-Produkt entschieden haben. Wir hoffen, dass unser Produkt Ihre Erwartungen erfüllen oder sogar übertreffen wird, weil wir uns zum Ziel gesetzt haben, hochwertige Produkte und Leistungen anzubieten, die Ihre uneingeschränkte Anerkennung verdienen werden!

Lesen Sie sich bitte die beiliegende Installations- und Betriebsanleitung durch. Es ist wichtig, dass die Installation entsprechend den Werksangaben erfolgt, damit Ihr Produkt mit maximalem Wirkungsgrad arbeiten kann.

Follett LLC ist nicht für Folgeschäden, Ausgaben, Gebühren für Anschluss oder Abschaltung oder Verluste aufgrund eines Defekts der Maschine haftbar.

Vollständige Garantieinformationen finden Sie auf unserer Website unter www.follettice.com/productwarranties.

Garantieregistrierung und Produktbeurteilung sind wichtig, damit wir einen Überblick über unsere Produkte behalten und ihre Effizienz bewerten können. Wir möchten Sie bitten, Garantien für Follett-Produkte auf unserer Website www.follettice.com/support zu registrieren und den Punkt „Garantieregistrierung und Produktbeurteilung“ zu wählen. Es ist ganz einfach. Nehmen Sie sich bitte einen Moment Zeit, um die Registrierung heute vorzunehmen. Auf dem Formular ist auch Platz für Kommentare und Feedback vorhanden. Teilen Sie uns bitte Ihre Erfahrungen mit unseren Produkten mit, damit wir sie für unsere fortlaufenden Produktverbesserungen verwenden können.

Wir sind stolz darauf, dass wir besondere Produkte herstellen, und wir bemühen uns, unsere Produkte mit besonderem Kundendienst zu unterstützen. Lassen Sie uns bitte wissen, was wir noch für Sie tun können. Wir werden Ihre Fragen gerne beantworten.

Registrazione della garanzia e valutazione dell'attrezzatura

Grazie per aver acquistato un dispositivo Follett®. Ci auguriamo che il nostro prodotto soddisfi o superi le Sue aspettative, in quanto il nostro obiettivo è quello di offrire prodotti e servizi di alta qualità che soddisfino pienamente le vostre esigenze!

La preghiamo di leggere attentamente il manuale per l'installazione e per l'uso allegato. È infatti importante che l'installazione sia effettuata secondo le specifiche di fabbrica in modo tale che il dispositivo operi con la massima efficienza.

La Follett LLC non si assume alcuna responsabilità per danni conseguenti, spese, costi di collegamento o scollegamento o eventuali perdite dovute ad un difetto della macchina.

Per visualizzare i dettagli completi relativi alla garanzia, recarsi alla pagina www.follettice.com/productwarranties.

La registrazione della garanzia e la valutazione dell'attrezzatura sono importanti per aiutarci a tenere traccia dei nostri dispositivi e a registrare le prestazioni della macchina. Le chiediamo dunque di registrare le garanzie relative al dispositivo Follett sul nostro sito Web alla pagina www.follettice.com/support scegliendo Registrazione della garanzia e Valutazione dell'attrezzatura. Farlo è semplice; dedichi pochi minuti a registrare il prodotto oggi stesso. Sul modulo è inoltre previsto uno spazio in cui potrà fornirci i Suoi commenti e il Suo riscontro. Ci faccia sapere della Sua esperienza in modo che possiamo farne tesoro per il nostro continuo miglioramento.

Siamo orgogliosi di produrre macchinari di ottima qualità e lavoriamo sodo per offrire un servizio di assistenza clienti e tecnico di qualità altrettanto elevata. Ci faccia sapere come possiamo esserle di aiuto. Saremo lieti di rispondere a tutte le Sue domande.

Registo da garantia e avaliação do equipamento

Obrigado por ter adquirido equipamento Follett®. Fazemos votos de que o nosso equipamento cumpra ou exceda as suas expectativas, dado que temos por objetivo fornecer produtos e serviços de elevado valor que mereçam a sua total satisfação!

Pedimos-lhe que leia o manual de instalação e operações em anexo. É importante que a instalação seja levada a cabo de acordo com as especificações da fábrica, para que o seu equipamento funcione com a eficiência máxima.

A Follett LLC não assume a responsabilidade por quaisquer prejuízos indiretos, despesas, custos de ligação ou desligação ou quaisquer outras perdas decorrentes de um defeito na máquina.

Para consultar os dados da garantia, visite o nosso website www.follettice.com/productwarranties.

O registo da garantia e a avaliação do equipamento são importantes para nos ajudar a estar a par do nosso equipamento e registar o desempenho da máquina. Pedimos-lhe que registe as garantias de equipamento Follett no nosso website www.follettice.com/support, em “Warranty Registration and Equipment Evaluation”. É muito simples; tire uns minutos para fazer o registo hoje mesmo. O formulário inclui também espaço para os seus comentários e feedback. Conte-nos a sua experiência para que possamos usá-la nos nossos esforços contínuos de melhoria.

Temos muito orgulho em produzir equipamento excepcional e empenhamo-nos em proporcionar um apoio técnico e um apoio ao cliente igualmente excecionais. Diga-nos o que mais podemos fazer para o ajudar. Teremos todo o prazer em responder às suas perguntas.

Registrering af garanti og evaluering af udstyr

Tak for dit køb af Follett®-udstyr. Forhåbentlig synes du, at vores udstyr lever op til eller overstiger dine forventninger, for vores målsætning er at levere produkter og serviceydelser af høj kvalitet, som du er fuldstændig tilfreds med!

Gennemlæs venligst den vedlagte installations- og driftsmanual. Det er vigtigt at installationen udføres i henhold til fabrikkens specifikationer, så dit udstyr kan fungere med maksimal effektivitet.

Follett LLC hæfter ikke for følgeskader, udgifter, tilslutnings- eller frakoblingsomkostninger eller nogen form for tab, der skyldes en maskindefekt.

Du kan læse de fulde oplysninger om garantien på vores website www.follettice.com/productwarranties.

Registrering af garantien og evaluering af udstyret er vigtigt for at hjælpe os med at følge op på vores udstyr og registrere maskinens ydelse. Vi beder dig registrere garantier på Follett-udstyr på vores website www.follettice.com/support og vælge Warranty Registration and Equipment Evaluation (Registrering af garanti og evaluering af udstyr). Det er nemt at gøre, så vi beder dig bruge et øjeblik på at registrere dig i dag. Formularen har også plads til, at du kan give os kommentarer og feedback. Fortæl os om dine erfaringer, så vi kan bruge dem i vores fortsatte bestræbelser på at forbedre os.

Vi sætter en ære i at fremstille udstyr i særklasse og arbejder hårdt på at kunne bakke udstyret op med fremragende kundeservice og teknisk support. Fortæl os, hvad vi ellers kan gøre for at hjælpe dig. Vi svarer gerne på dine spørgsmål.

Registratie van garanties en beoordeling van apparatuur

Gefeliciteerd met uw aankoop van Follett®-apparatuur. We hopen dat onze apparatuur uw verwachtingen invult of zelfs overstijgt, omdat we ernaar streven om hoogwaardige producten en diensten te leveren die u uitermate tevreden stellen!

Lees de bijgevoegde installatie- en bedieningshandleiding zorgvuldig door. Het is belangrijk dat de installatie uitgevoerd wordt volgens de fabrieksspecificaties, zodat uw apparatuur zo efficiënt mogelijk werkt.

Follett LLC is niet aansprakelijk voor enige gevolgschade, uitgaven, montage- of demontagekosten of enige door een defect van de machine geleden verliezen.

Bezoek onze website www.follettice.com/productwarranties voor alle garantiegegevens.

De registratie van garanties en de beoordeling van apparatuur is belangrijk voor ons om onze apparatuur te helpen traceren en de prestaties van de machine te registreren. We verzoeken u dan ook om garanties van Follett-uitrusting te registreren op onze website www.follettice.com/support en om "Warranty Registration" (Registratie van garanties) en "Equipment Evaluation" (Beoordeling van apparatuur) te kiezen. Gelieve hier even tijd voor vrij te maken. Het is namelijk zeer eenvoudig. Er is op het formulier ook plaats om opmerkingen en feedback te geven. Breng ons gerust op de hoogte over uw ervaring met onze apparatuur, zodat we ons kunnen blijven verbeteren.

We zijn trots op onze productie van uitstekende apparatuur en werken hard om dit bij te staan door een voortreffelijke klantendienst en technische ondersteuning. Aarzel echter niet om enige andere bijstand te vragen. We zullen uw vragen met plezier beantwoorden.

Garantiregistrering och utvärdering av utrustning

Tack för att du köpt utrustning från Follett®. Vi hoppas att du ska tycka att den uppfyller eller överträffar dina förväntningar, då vårt mål är att leverera produkter och tjänster av högt värde som gör dig helt nöjd!

Studera medföljande installations- och bruksanvisning. Det är viktigt att installationen genomförs enligt fabriken's anvisningar så att din utrustning arbetar med högsta effektivitet.

Follett LLC ansvarar inte för följdskador, kostnader, avgifter eller förluster som orsakats av fel på maskinen.

Fullständiga garantivillkor finns på vår hemsida www.follettice.com/productwarranties.

Garantiregistrering och utvärdering av utrustning är viktig för oss så att vi kan följa upp vår utrustning och dess funktion. Vi vill att du registrerar Folletts utrustningsgaranti på vår hemsida www.follettice.com/support, där du väljer Garantiregistrering och produktutvärdering. Det är enkelt att göra, så ta dig tid en minut och registrera dig idag. Det finns också utrymme på blanketten för kommentarer och synpunkter. Berätta för oss vad du tycker så att vi kan använda det i våra ansträngningar att alltid bli bättre.

Vi är stolta över att producera överlägsen utrustning och vi arbetar hårt med att stötta den med överlägset kundansvar och tekniskt stöd. Tala om för oss vad vi kan göra mer för att hjälpa dig. Vi svarar gärna på dina frågor.

Warranty Registration and Equipment Evaluation

Thank you for purchasing Follett® equipment. We hope you find that our equipment meets or exceeds your expectations, as our goal is to deliver high value products and services that earn your complete satisfaction!

Please review the enclosed installation and operations manual. It is important that the installation be performed to factory specifications, so your equipment operates to its maximum efficiency.

Follett LLC will not be liable for any consequential damages, expenses, connecting or disconnecting charges or any losses resulting from a defect of the machine.

For full warranty details, visit our website www.follettice.com/productwarranties.

Warranty registration and equipment evaluation is important to help us keep track of our equipment and to record the machine's performance. We request that you register Follett equipment warranties on our website www.follettice.com/support and choose Warranty Registration and Equipment Evaluation. It's simple to do; please take a moment to register today. There is also space on the form to provide us with comments and feedback. Please let us know about your experience so we can capture it for our continuous improvement efforts.

We pride ourselves on producing outstanding equipment and we work hard to back it up with outstanding customer and technical support. Please let us know what else we can do to assist you. We would be happy to answer your questions.

RIDE is a trademark of Follett LLC.
Chewblet is a registered trademark of Follett LLC, registered in the US.



801 Church Lane • Easton, PA 18040, USA
Toll free (877) 612-5086 • +1 (610) 252-7301
www.follettice.com



00120527R04
© Follett LLC 5/17