

VU300K Series Integral Cold Carbonation Ice and Beverage Dispensers

Order parts online
www.follettice.com

Installation, Operation and Service Manual

Service numbers above 50000

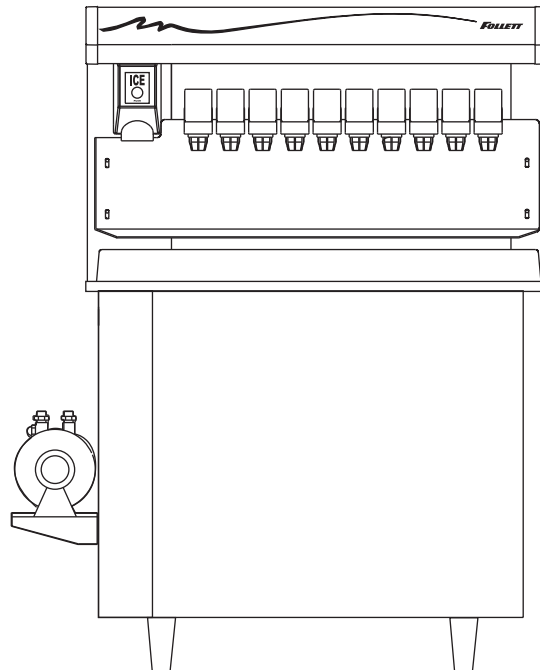

**Following installation, please forward this manual
to the appropriate operations person.**

This page intentionally left blank.

Table of contents

Welcome to Follett Corporation	4
Important cautions	4
Specifications	5
Installation	8
Installing dispenser in counter	8
Field wiring diagrams	9
Connecting beverage lines	9
Installing optional ice machine	10
Operation	11
How the dispenser works	11
Cleaning	12
Service	14
Dispense chute cover removal	14
Auger motor assembly removal	14
Gate assembly removal	14
Auger and auger tube removal	14
Dispenser wheel removal	14
Wiring diagrams	15
Troubleshooting	17
Replacement parts	19

Welcome to Follett

Follett equipment enjoys a well-deserved reputation for excellent performance, long-term reliability and outstanding after-the-sale support. To ensure that this dispenser delivers that same degree of service, we ask that you take a moment to review this manual before beginning the installation of the dispenser. Should you have any questions or require technical help at any point, please call our technical service group, (877) 612-5806 or +1 (610) 252-7301.

Before you begin

After uncrating and removing all packing material, inspect the equipment for concealed shipping damage. If damage is found, notify the shipper immediately and contact Follett Corporation so that we can help in the filing of a claim, if necessary.

Check your paperwork to determine which model you have. Follett model numbers are designed to provide information about the type and capacity of Follett ice dispensing equipment. Following is an explanation of the different model numbers in the VU300 series.

VU300K8LP

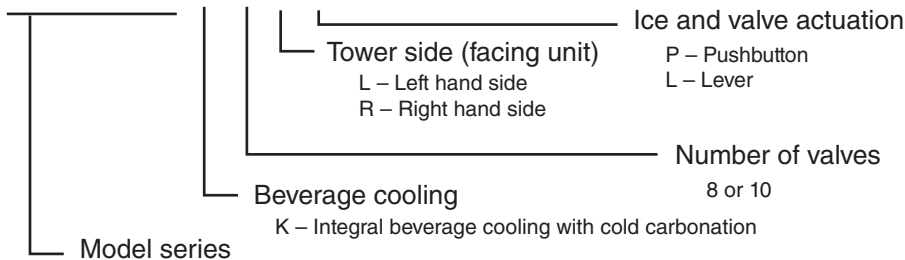

Important cautions

Storage area of dispenser contains mechanical, moving parts. Keep hands and arms clear of this area at all times. If access to this area is required, power to unit must be disconnected first.

Ice is slippery. Maintain counters and floors around dispenser in a clean and ice-free condition.

Ice is food. Follow recommended cleaning instructions to maintain cleanliness of delivered ice.

Always disconnect power before cleaning or servicing the dispenser.

Failure to remove all sanitizer may result in health hazard.

Follett manual load dispensers can accommodate most cube/cubelet ices up to 1" square, or Follett compressed nugget ice. Crushed, flake, bagged, nugget or congealed ice cannot be used. Use of these ices can jam dispenser and void warranty. Separate any "waffle-like" sections of cubes before adding to dispenser. For ice compatibility questions, please call Follett customer service at (877) 612-5806 or +1 (610) 252-7301.

Specifications

Electrical

Each dispenser requires a separate circuit with electrical disconnect within 10 ft (6m). Equipment ground required. Standard electrical – 115V, 60Hz, 1 phase. Maximum dispenser fuse – 20 amps; maximum ice machine fuse – 20 amps each. Cord and plug provided with each dispenser.

	Ice machine amperage	Dispenser amperage
VU300K series	11.0 amps ea (2)	11.5 amps

Plumbing

Dispenser 3/4" PVC pipe nipple for bin drain
 3/4" PVC pipe nipple for drain pan drain
 1" ID hose for beverage bath drain

Beverage connections

1/4" ID syrup beverage hose
3/8" 45° flair fitting for carbonated water inlet
1/4" ID CO₂
3/8" ID plain water inlet

Note: Set CO₂ pressure to 75 psi and syrup pressure to 60 psi.

Drains should be hard piped and insulated. Maintain at least 1/4" per foot (6mm per 304mm run) slope on drain line run.

Water disconnect within 10 feet (3m) of dispenser is suggested for automatic load units.

Follett recommends use of a Follett water filter system (part# 00130229) on ice machines connected to automatic fill dispensers.

Ice machine Refer to detailed specifications in ice machine installation manual packed with ice machine

Dimensions and clearances

VU300 series

Required clearances

60" (1524mm) minimum above counter for installation if dispenser will be dropped into counter

49" (1245mm) minimum above counter for auger removal

12" (305mm) minimum on ice chute side for service

12" (305mm) minimum on side opposite ice chute if ice transport tube enters this side

12" (305mm) minimum between dispenser side(s) and optional ice machine(s)

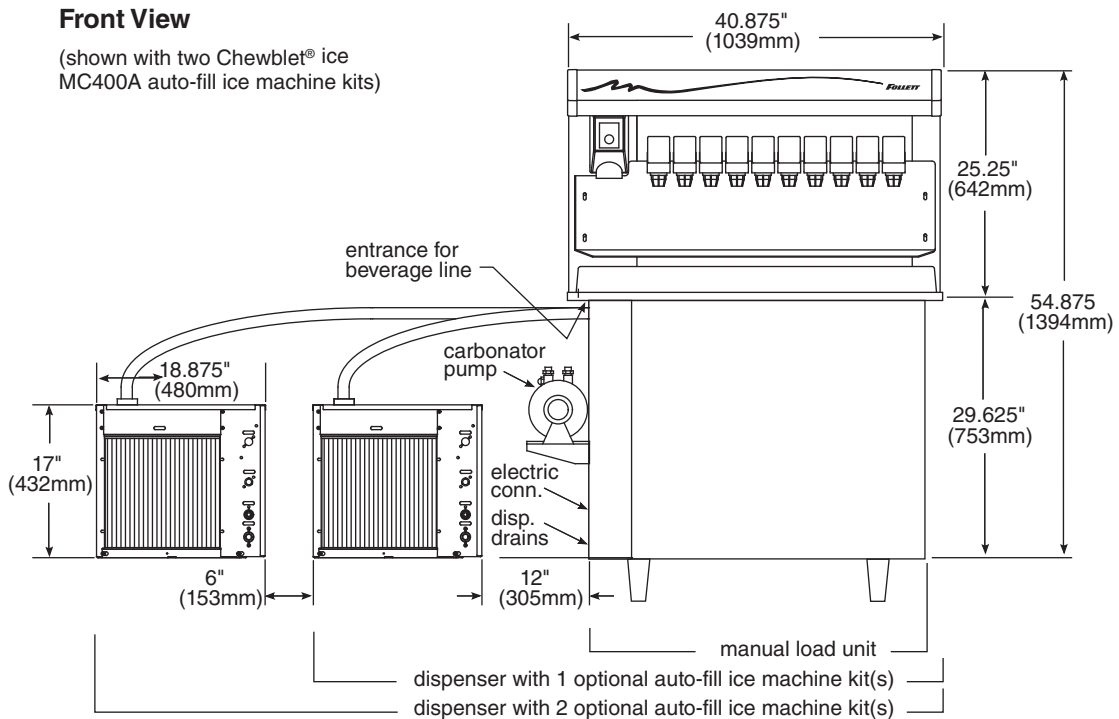

Side View

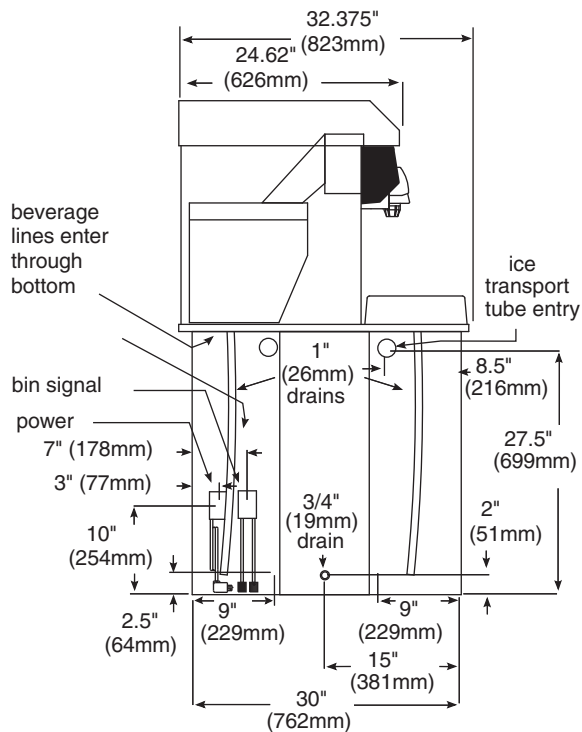

Installation

Installing dispenser in counter

Note: All dispensers must be supported from below with supplied 4" – 6" (102 – 153mm) adjustable leg accessory, or equivalent. Do not hang dispenser on flange.

All dispensers must be installed level in both directions to ensure proper operation.

1. Check that dispenser location meets all requirements in this manual and cut counter as shown.

Plan View Single-sided dispensers counter cutout

Shaded area is additional cut-out required for slide-in installations only

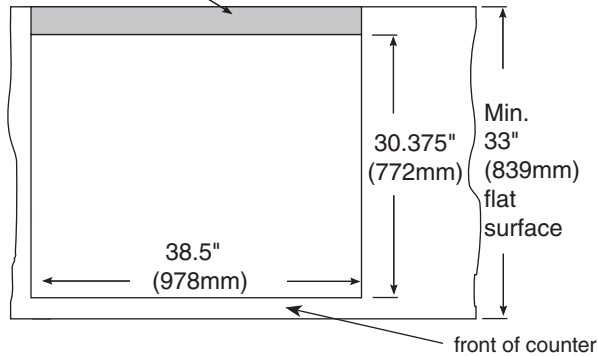

2. Place support blocks in cabinet to raise dispenser to a height of 12" (305mm).
3. Place dispenser in counter onto support blocks.
4. Attach adjustable legs to dispenser.
5. Remove support blocks and lower dispenser feet to floor.
6. Adjust legs for 1/8" (4mm) clearance between dispenser lip and countertop to verify there is no load on flange.
7. Apply a bead approximately 1/4" (6mm) in diameter of NSF-listed silicone sealant (Dow Corning RTV-732 or equivalent) around perimeter of dispenser where it meets counter. Smooth sealant to a 1/8" (4mm) radius.
8. Install a PVC drain line with at least a 1/4" per foot (20mm per 1m) slope. Insulate drain line to prevent condensation.

Note: Do not apply excessive heat if any sweating of fittings is necessary. Heat conduction through metal may melt threads in plastic drain.

Do not reduce drain line size or tie drains together.

9. Install carbonator pump. See instruction enclosed with pump for detailed installation instructions.
10. Make electrical connections in accordance with applicable wiring diagrams provided. Provide disconnects within 10 ft (3m) of dispenser and ice machine for servicing.

Field wiring diagrams

Note: Field wiring diagrams are intended to aid electricians or technicians in understanding how equipment works. All field wiring must be installed in accordance with all local and NEC codes.

If attaching optional ice machine accessory

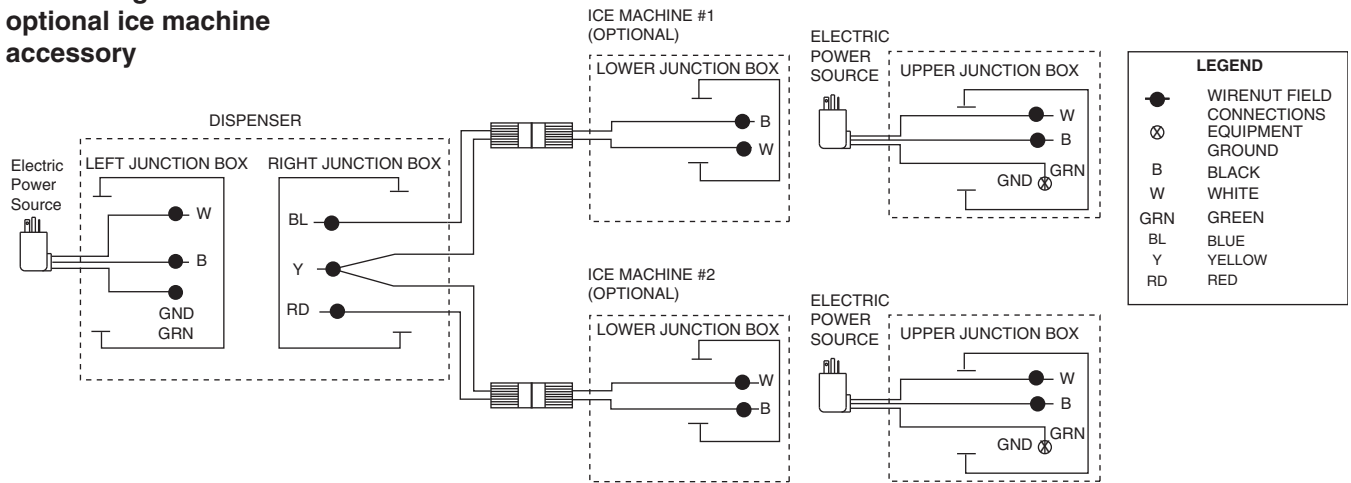

Connecting beverage lines

1. Connect syrup and water lines. Non-carbonated water line will be labeled “water.” Syrup lines are numbered and correspond to the valves as shown in drawing(s) below. Valve one is always next to ice tower.
2. The center 4 valves are pre-plumbed to both carbonated and non-carbonated water lines with the QuickCARB™ beverage manifold. Valves can be individually changed from carbonated to non-carbonated flavor with the flip of a lever (see below).
3. Clean and sanitize beverage lines in accordance with cleaning instructions.

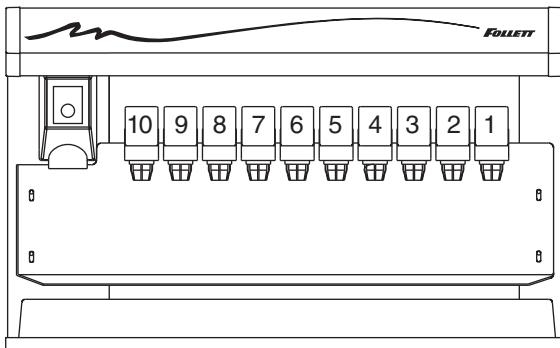

Valve position #1 is always next to ice tower. Left hand unit shown.

VU300B QuickCARB manifold (see dispenser for model specific QuickCARB configuration)

Rear View

carbonated

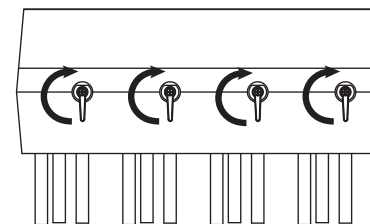

non-carbonated

Installing optional auto-fill ice machine kit(s)

Correct installation of RIDE™ model ice machine(s) is critical to proper performance of ice machine. Refer to installation manual packed with ice machine for important details on ice transport tube run, ventilation requirements and other installation requirements. Failure to comply with instructions may void warranty.

To start and operate dispenser

1. Follow detailed cleaning instructions in service manual before operating dispenser.
2. Slowly pour water into ice water bath area to fill empty bath and submerge coils. Coils are submerged when water starts to flow out overflow drain. **DO NOT SPLASH WATER ON ELECTRICAL BOX.** Once filled with water, add ice to bath until ice covers top of waterbath.
3. For manual load units, remove front drain pan or rear lid and fill storage area with approved ice.

Note: Follett manual load dispensers can accommodate most cube/cubelet ices up to 1" square, or Follett compressed nugget ice. Crushed, flake, bagged, nugget or congealed ice cannot be used. Use of these ices can jam dispenser and void warranty. Separate any "waffle-like" sections of cubes before adding to dispenser. For ice compatibility questions, please call Follett customer service at (877) 612-5806 or +1 (610) 252-7301.

4. Turn power switch located on dispenser control box to ON position.
5. For automatic fill units, follow detailed instructions in ice machine installation section of installation manual, then turn ice machine (bin signal) switch(es) located on dispenser control box to ON position and begin to make ice.
6. When dispenser has at least 6" (153mm) of ice in storage area, test operation.

Operation

How the dispenser works

Follett's dispensers may be fed by Follett RIDE model ice machines or manually loaded (using ice from another source).

In all models, ice is stored below the counter in the dispenser storage area. When the dispense lever or button is pushed, the dispense motors are activated. This causes the wheel assembly in the storage area to turn, moving ice to the vertical auger assembly, which carries ice up to the dispense chute where it drops by gravity into the container.

In units used with an optional ice machine accessory, ice is manufactured remotely and may be located up to 20 ft (6m) away from the dispenser. Extruded ice is transported through a tube and pushed to the storage compartment of the dispenser. When the bin is filled, a bin thermostat shuts the ice machine off to avoid overfilling the bin. The ice machine will restart after 20 minutes if the bin is calling for ice.

Units with integral ice water bath beverage cooling are equipped with a waterbath timer circuit that activates the water bath pump for 35 minutes when ice lever or button is activated, or when the ice water bath warms up and calls for more ice.

Ice movement

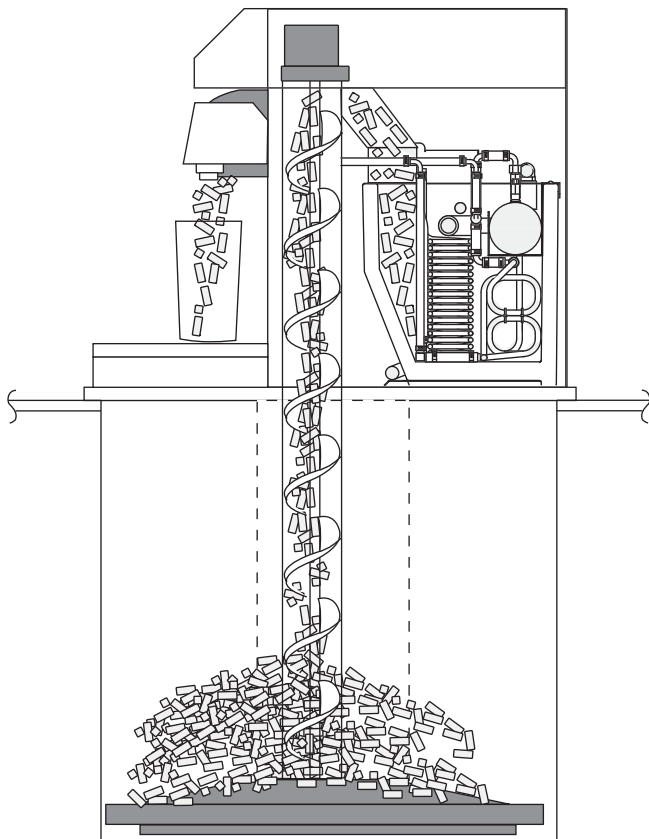

Cleaning

Using solutions below, clean and sanitize storage area and beverage lines before starting unit and on a routine basis as noted below.

Note: Always disconnect power before cleaning dispenser.

Do not run plastic parts through a dishwasher.

Solution A: Combine 1 oz (30ml) bleach with 2 gal (8L) hot water.

Solution B: Combine 1/4 oz (7ml) bleach with 2 gal (8L) hot water.

Note: Cleaning solutions temperature must be at 75 F – 125 F (24 C to 52 C)

Recommended cleaning prior to start up

Cleaning ice storage area before use

1. Refer to disassembly instructions (see Service section) and remove dispense wheel from ice storage area.
2. Remove auger, auger tube and dispense mechanism.
3. Wipe all components and ice storage area with cleaning Solution A.
4. Rinse all components and ice storage area thoroughly with clear, potable water.
5. Wipe all components and ice storage area with sanitizing Solution B.

Cleaning beverage lines

Prepare 6 gallons (23L) of cleaning Solution A. Fill a clean product tank with cleaning solution. Fill a second clean product tank with potable rinse water.

1. Disconnect all syrup lines from product containers.
2. Connect syrup line #1 to cleaning solution tank, pressurize tank to 20-50 psi, and dispense 1/2 gallon (2L) of solution into a suitable container from valve #1.
3. Connect syrup line #1 to rinse tank, pressurize tank to 20-50 psi, and dispense 3 gallons (11L) into a suitable container from valve #1.
4. Repeat this cleaning and rinsing for all syrup lines.
5. Remove diffusers and nozzles from valves, soak in cleaning solution, rinse well and reinstall.

Sanitizing beverage lines

Prepare 6 gallons (23L) of sanitizing Solution B. Fill a clean product tank with this solution.

1. Connect one tank to syrup line #1. Dispense 1/2 gallon (2L) from valve #1.
2. Repeat for all remaining syrup lines, allowing sanitizing solution to remain in all circuit lines for 15 minutes.
3. Connect a clean, empty tank (pressurized to 50 psi) to each syrup line and blow out sanitizer by operating each valve.
4. Remove diffusers and nozzles from valves, soak in sanitizing solution for 15 minutes, rinse well and reinstall.
5. Reconnect all lines and dispense product through valves to purge any remaining sanitizer.

Recommended daily dispenser cleaning

1. Remove all debris from drain pan.
2. Pour 1 gallon (4L) hot water into drain pan to keep drain lines clear.

Recommended weekly dispenser cleaning

1. Remove drain pan and grille and wash with Solution A. Rinse thoroughly.
2. Remove nozzles and diffusers from valves, soak for at least 10 minutes in cleaning Solution A, rinse, sanitize with Solution B and reinstall.
3. Pour a solution of one cup (8oz/237ml) household bleach mixed with one gallon (3.8L) hot water into drain pan to help prevent algae growth in drain lines.

Recommended quarterly dispenser cleaning

1. Remove top from dispenser and turn power switch to OFF position.
2. Remove ice from storage area.
3. Remove dispense chute cover, chute, auger motor assembly, auger and auger tube (see Service section).
4. Remove drain pan, grille, dispense wheel, agitator rods, and drive shaft (see Service section).
5. Clean all components and bin storage area with Solution A, rinse thoroughly with clear water and sanitize with Solution B.
6. Remove nozzles and diffusers from valves, soak for at least 10 minutes in cleaning Solution A, rinse, sanitize with Solution B and reinstall.
7. Remove side access panel next to ice tower with two upper screws and lift out.
8. Disengage service drain tube (on utility connection side of dispenser) from mounting bracket and drain ice water bath.
9. Use a bottle brush to clean coils with Solution A, rinse and sanitize with Solution B.
10. Reposition ice water bath drain line in up position so water does not drain out.
11. Pour Solution A into ice water bath until it flows out overflow drain.
12. Turn power ON to unit and dispense a small cup of ice to activate pump.
13. Allow pump to run for two minutes to clean pump and pump lines.
14. Turn power OFF.
15. Drain bath and replace drain tube in mounting bracket in up position to avoid siphoning water bath water.

Putting unit back in service after quarterly cleaning

1. Fill ice water bath with water until water spills out of bath overflow drain.
2. Reassemble components.
3. For manual load units, fill unit with an approved ice (see important cautions on page 4).
4. For automatic load units with R400A/W (R404A refrigerant) ice machines, turn bin signal switch(es) and dispenser power switch to ON position and allow storage area to fill.
5. Push dispense button or lever to test that dispenser is functioning properly.

Recommended quarterly cleaning of optional auto-fill ice machine kit(s).

Units equipped with optional ice machines require cleaning of ice machine system at least every six months, and more often if local water conditions dictate. Failure to clean ice machine system will result in decreased performance and potential damage to ice machine. Refer to Ice machine Installation, Operation and Service Manual.

Service

Dispense chute cover removal

1. Remove top cover.
2. Remove two screws from top cover and pull cover forward and down to remove.
3. On push button units, disconnect plug on harness.

Auger motor assembly removal

1. Remove drain pan.
2. Remove thumbscrews from splash guard and remove.
3. Remove thumbscrews from splash panel; lift and pull forward at base of panel and remove.
4. Unplug auger motor at connector.
5. Remove two 1/4-20 bolts holding auger motor to hold-down bracket.
6. Remove two thumbscrews from auger motor stabilizer bracket and set aside.
7. Lift auger motor off.

Gate assembly removal

1. Remove dispense chute cover and auger motor assembly.
2. Remove thumbscrews on each side of clear focus chute and remove.
3. Remove quick release pin holding dispense gate assembly and chute.
4. Lift gate up and over hinge tabs, then carefully pull and tilt to unhook from solenoid link.
5. Pull ice chute toward you to unclip from dimples on chute mounting bracket.
6. Pull ice chute and gate toward you and out through panel opening.
7. Lift dispenser mechanism assembly off auger and auger tube.

Auger and auger tube removal

1. Remove dispense chute cover and auger-motor assembly.
2. Remove side panel of tower.
3. Remove screw holding top auger tube ring to lower ring.
4. Lift auger out of auger tube.
5. Lift out auger tube, turning as needed to clear rivnuts on side auger motor mounting bracket.

Dispenser wheel removal

1. Remove dispenser top and turn power switch OFF.
2. Remove all ice from bin.
3. Remove drain pan and ice bin access cover below it.
4. Remove splash guard and wheel motor access cover.
5. Unplug wheel motor at connector and remove ground wire.
5. Remove wheel motor by pulling out two quick release pins.
6. Lift drive shaft up through hole in countertop.
7. Lift dispense wheel out through drain pan opening.

Dispense chute assembly

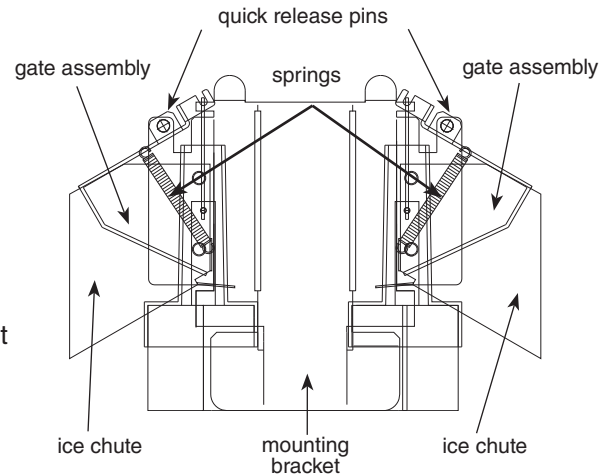

Dispenser cutaway – Front View

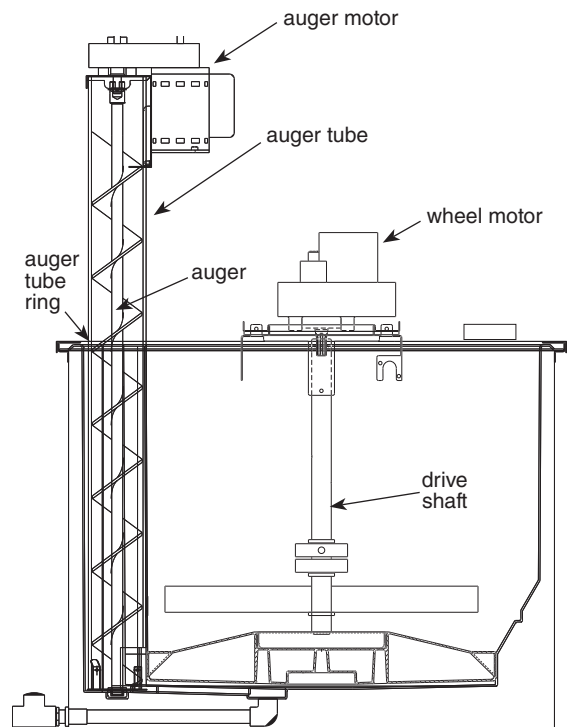

Front View

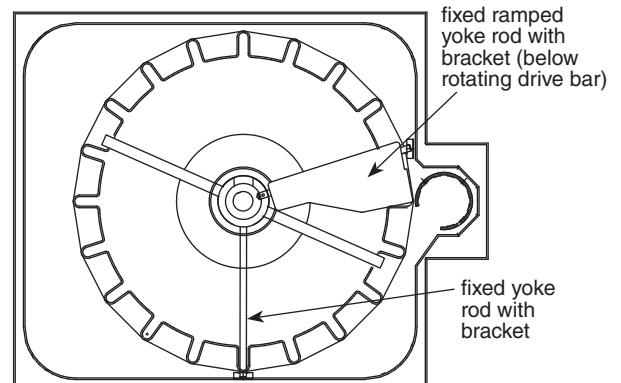

Wiring diagram

VU300K series

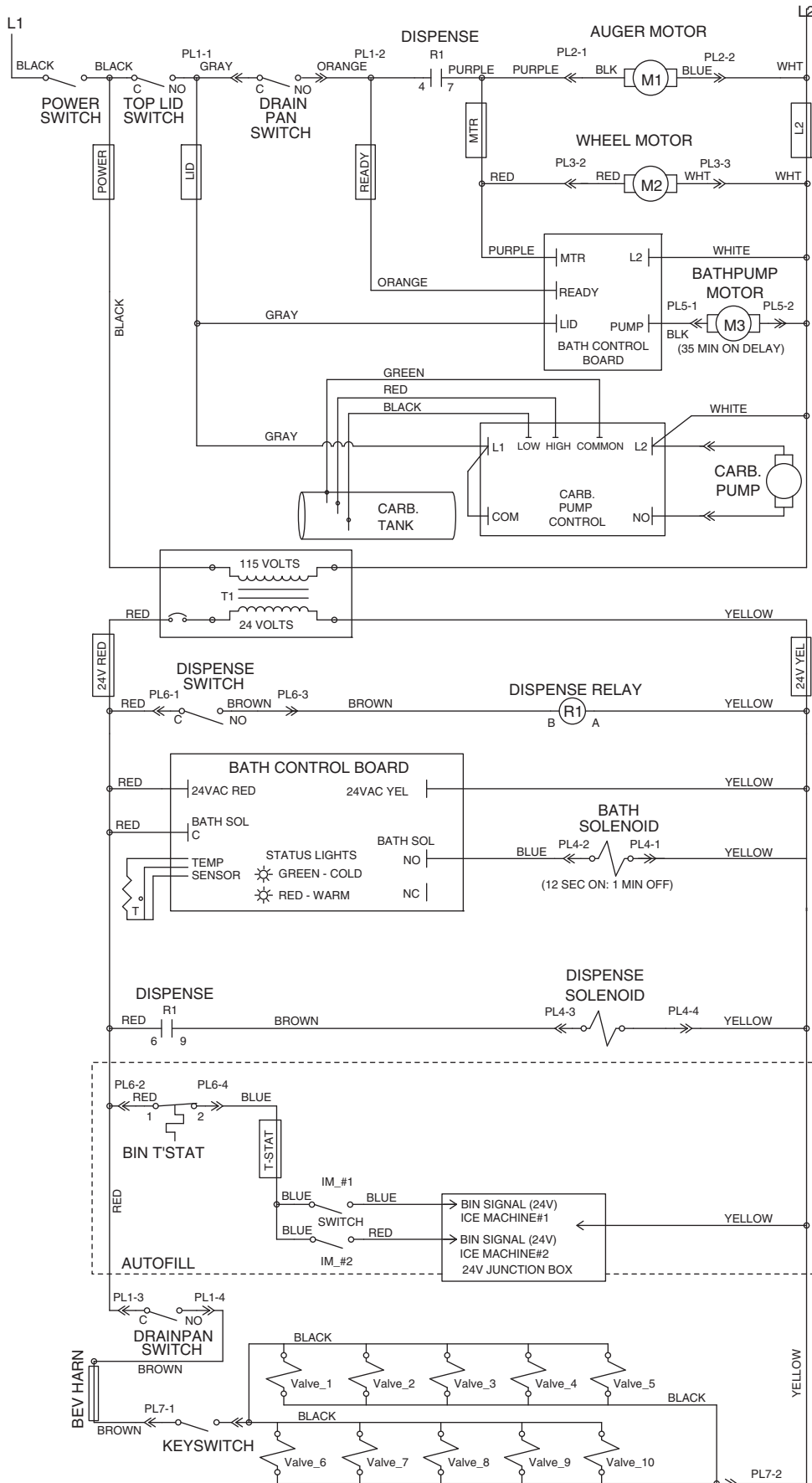

LEGEND:

- TERMINAL STRIP CONNECTION
- PIN and SOCKET CONNECTION

Dispenser troubleshooting guide

Before calling for service

1. Check that ice is in the dispenser and that congealed cubes are not causing a jam.
2. Check that circuit breaker and switches are in ON position.
3. Check that drain pan and top are on securely. If ajar, dispenser will not operate. When the top is off, auger does not operate, even though the solenoids do (page 18).
4. Check that all drains are clear.

Note: For units equipped with Follett Chewblet auto-fill ice machine kit(s), see Ice Machine Operation and Service Manual for service and troubleshooting information.

Symptom	Possible cause	Solution
Ice does not dispense. <ul style="list-style-type: none"> • Auger motor does not run • Wheel motor does not run 	<ol style="list-style-type: none"> 1. Power switch faulty or in OFF position; loose connection. 2. Faulty dispense switch. 3. Faulty transformer. 4. Drain pan ajar. 5. Faulty drain pan safety switch. 	<ol style="list-style-type: none"> 1. Turn power switch to ON position; check connections. 2. Replace switch. 3. Replace transformer. 4. Check pan and reset. 5. Replace switch.
Ice does not dispense. <ul style="list-style-type: none"> • Auger motor runs • Wheel motor runs • Gate does not open 	<ol style="list-style-type: none"> 1. Loose electrical connection. 2. Linkage problem between solenoid and gate. 3. Faulty solenoid. 	<ol style="list-style-type: none"> 1. Check connections. 2. Check linkage. 3. Replace solenoid.
Ice does not dispense. <ul style="list-style-type: none"> • Auger motor does not run • Wheel motor runs 	<ol style="list-style-type: none"> 1. Loose electrical connection. 2. Faulty auger motor. 3. Faulty run capacitor. 	<ol style="list-style-type: none"> 1. Check connections. 2. Check auger motor. 3. Check run capacitor.
Ice does not dispense. <ul style="list-style-type: none"> • Auger motor runs • Wheel motor does not run 	<ol style="list-style-type: none"> 1. Loose electrical connection. 2. Faulty wheel motor. 3. Faulty run capacitor. 	<ol style="list-style-type: none"> 1. Check connections. 2. Check wheel motor. 3. Check capacitor.
Warm drinks or soda foaming.	<ol style="list-style-type: none"> 1. No ice in storage bin. 2. Water drained out of ice water bath. 3. Circulating pump not running. 4. Board off on fill error. 5. CO₂ pressure is set too high. 	<ol style="list-style-type: none"> 1. Fill storage area with ice or check ice machine operation. 2. Check that ice water bath drain tube is in fixed upright position. 3. Check pump and PC board for output. 4. Cycle power on/off to reset board. 5. Set CO₂ pressure to 75 psi.
No ice in dispenser.	<ol style="list-style-type: none"> 1. Power switch in OFF position or faulty. 2. Bin signal switches in OFF position or faulty. 3. Faulty bin thermostat. 4. Faulty transformer. 5. Ice machine related problem. 6. Faulty or disconnected wiring. 	<ol style="list-style-type: none"> 1. Check switch and replace if necessary. 2. Check switch and replace if necessary. 3. Replace bin thermostat. 4. Replace transformer. 5. Refer to Ice machine Operation and Service Manual for diagnosing. 6. Check for power and bin signal on ice machine PC board.

Symptom	Possible cause	Solution
Carbonator pump not turning on.	<ol style="list-style-type: none"> 1. Loose connection. 2. Electrode connections on carbonator tank are satisfied. 3. Carbonator pump or level control board is defective. 	<ol style="list-style-type: none"> 1. Check carbonator pump power at plug and at level control board. 2a. Check connection between low level electrode and level control board. 2b. Check ground wire on carbonator tank. 3. Replace pump/control board.
Carbonator pump is not turning off.	<ol style="list-style-type: none"> 1. Loose connection. 	<ol style="list-style-type: none"> 1a. Check connection between high level electrode and level control board. 1b. Replace electrodes/control board.
Carbonation system is not carbonating.	<ol style="list-style-type: none"> 1. Loose connection. 2. CO₂ pressure. 3. Water pressure is too high. 4. Carbonator pump is defective. 	<ol style="list-style-type: none"> 1. Check all CO₂ and water connections. 2. Set CO₂ pressure to 75 psi. 3. Lower water pressure to approximately 50 psi. 4. Replace pump.
Carbonation system is producing excessively carbonated beverages.	<ol style="list-style-type: none"> 1. CO₂ pressure is set too high. 2. Drinks may be warm. 	<ol style="list-style-type: none"> 1. Set CO₂ pressure to 75 psi. 2. See “warm drinks” symptom.

If problems persist after following this basic troubleshooting guide, call Follett’s technical service department at (877) 612-5806 or +1 (610) 252-7301.

Operational Status

The chart below shows the operational status of various parts when certain switches are turned off or accessories are removed.

Condition	Pump	Solenoids	Auger	Wheel	Beverage valves
Top lid off	OFF	ON	OFF	OFF	ON
Drain pan off	ON	ON	OFF	OFF	OFF
On/off switch in OFF position	OFF	OFF	OFF	OFF	OFF
Beverage switch in OFF position	ON	ON	ON	ON	OFF

Waterbath circuit board operation

The temperature sensor is hard wired directly to the circuit board. The waterbath circuit board operates on 24 volts AC. The bath pump will run for 35 minutes whenever ice is dispensed or the bath calls for ice.

Optimal beverage temperature is controlled by the circuit board located in the electrical box. The board monitors the waterbath temperature and holds it to a factory setting. When the Red LED is ON, the bath solenoid, auger motor, wheel motor and bath pump are energized. Ice will be dispensed into the waterbath for 12 seconds, then stop for 60 seconds. The pump will stay energized, and the circuit board will then monitor the water temperature. If it is below the set point, the Green LED will come on, the Red LED light will go off, and ice will not dispense into the waterbath. If the temperature of the bath is determined to be above the set point, the Red LED will remain on. The circuit board has a delay of 60 seconds before more ice is dispensed into the waterbath.

LED indicators:

Green – the waterbath is at the set temperature.

Red – the bath temperature is above the set temperature and the bath is calling for ice.

Flashing LED indicators:

Flashing Red and Green – the circuit board has gone into an **error mode**:

Alternate flashing – circuit board has power and is waiting for hopper cover and dispenser top to be replaced.

Simultaneous flashing – the waterbath did not reach set temperature in 40 minutes. Reset this error mode by turning power off, removing top lid, drain pan or rear lid.

Electrical box – Front View

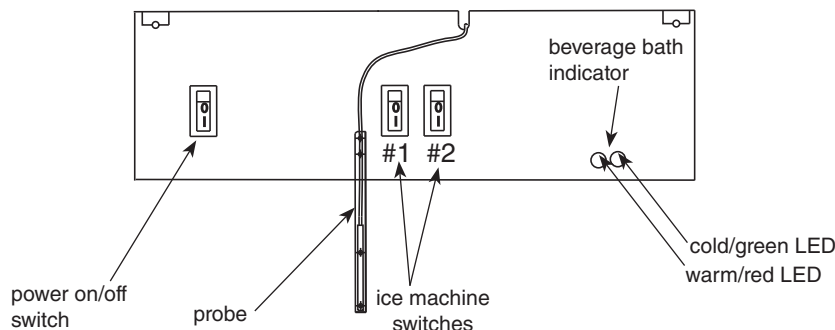

Replacement parts

Order parts online
www.follettice.com

Dispenser exterior (single-sided dispenser)

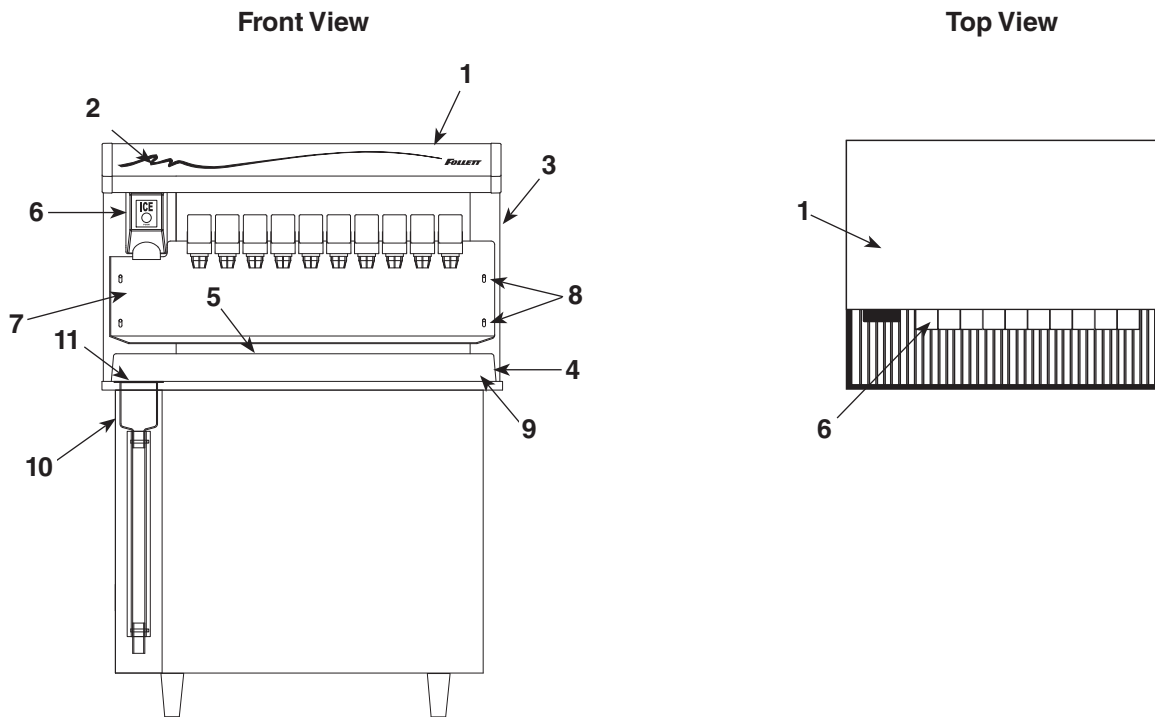

Reference #	Description	Part #
1	Lid, with graphics, single-sided	00126805
2	Graphics, "Follett"	00116780
3	Access panel, tower, single-sided	00108407
Not shown	Cover, ice opening (below drain pan)	00143685
Not shown	Drain pan assembly and grille	00126862
4	Drain pan, plastic	00108829
Not shown	Switch, drain pan safety	502475
5	Grille, drain pan	00108845
6	Chute cover, dispense, push-button with switch	502440
Not shown	Chute cover, dispense, lever	502439
7	Splash guard	00121517
8	Thumbscrew, 10/32-1/2, splash guard	501100
9	Bracket, drain pan locator	00143693
10	Drain box	00155218
11	Bracket, drain box and pan locator	00155200
Not shown	Switch, dispense, push-button	502441
Not shown	Switch, dispense lever (includes boot and spacer)	501714
Not shown	Boot, dispense switch button, lever	501841
Not shown	Access cover, wheel motor (behind splash guard)	00114546
Not shown	Fitting, drain, drain pan, brass	00143677
Not shown	Lip kit (plastic strip bordering ice bin opening and adhesive)	502285
Not shown	Insulation, transport tube (sold by the foot)	501176
Not shown	Tube, ice transport, 10 ft	502522
Not shown	Tube, ice transport, 20 ft	502523
Not shown	Plug 2 lead, male	502333
Not shown	Plug 2 lead, female	502334

Hopper

Order parts online
www.follettice.com

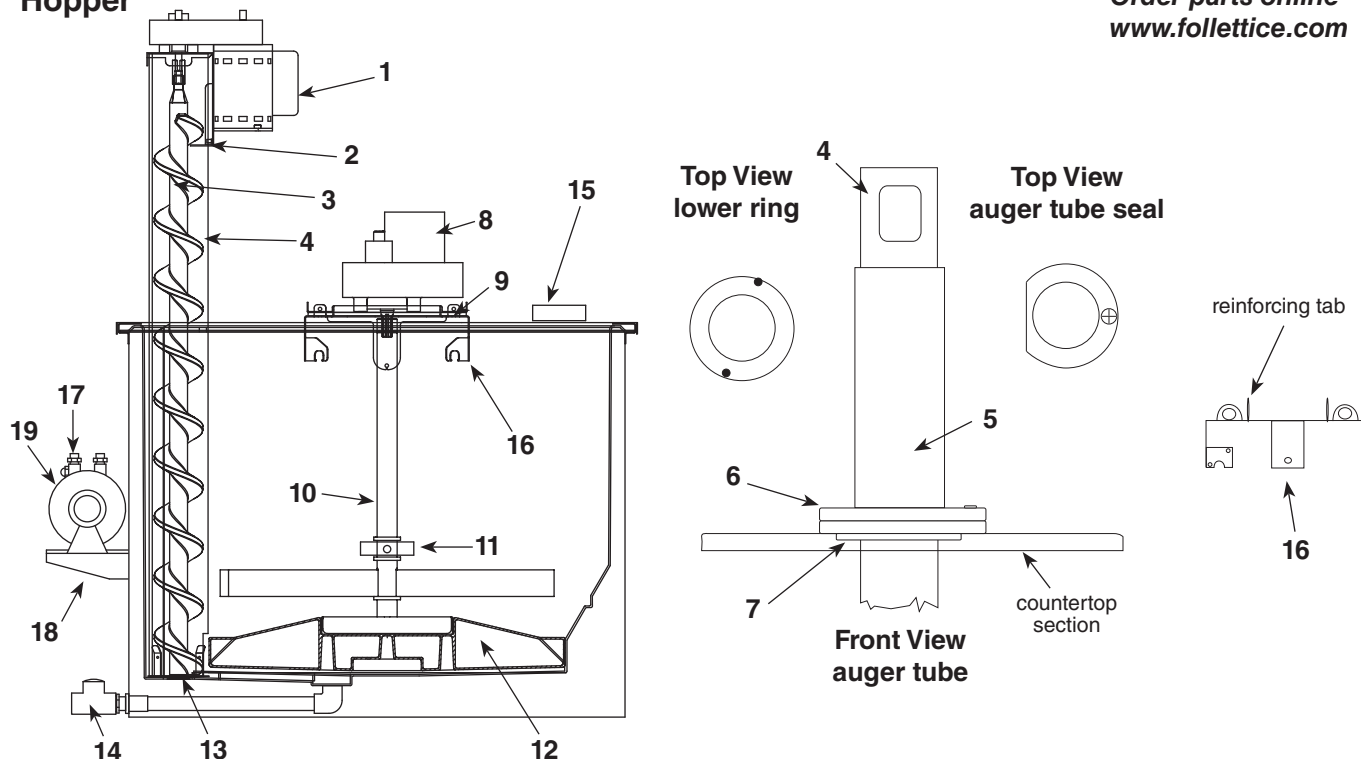

Reference #	Description	Part #
1	Motor, auger (includes capacitor), 100 RPM*	00918904
	*Note: If your machine serial number precedes C69443, then you need to order motor and bracket kit, part# 00923029.	
2	Bracket, auger motor hold-down	502047
Not shown	Bracket, auger motor stabilizer	00108498
Not shown	Seal, shaft, auger motor	501977
3	Auger	501980
4	Auger tube (includes insulation)	00126870
5	Insulation, auger tube	502099
6	Ring, auger tube, upper	501939
7	Ring, auger tube, lower	502155
8	Motor, wheel, Brother (includes capacitor)	502657
9	Bracket, wheel motor	501981
Not shown	Capacitor, wheel motor, Brother	502658
Not shown	Gasket, wheel motor bracket	501982
Not shown	Pin, quick release, wheel motor (2 required)	206283
10	Drive shaft assembly, for Brother motor	00126888
11	Agitator rods, fixed, front and back	502629
12	Wheel, dispense	501978
13	Bearing plate, bottom auger	501971
Not shown	Bearing, bottom, auger	501972
Not shown	Agitator rod, ramped	502628
Not shown	Bracket, fixed agitator (3 used per unit)	501974
Not shown	Thumbscrew, 10/32 x 3/4, fixed agitator bracket (2 required)	501259
14	Tee, drain	502059
15	Thermostat	500514
16	Bracket, ice hose and wheel motor	502050
17	Union, 3/8" (includes 00107433)	00107516
18	Shelf, carbonator pump	00106658
19	Pump, carbonator (includes 00106658, 00109355)	00107524
Not shown	Mounting screws & fittings, carbonator pump	00109355
Not shown	Leg	00137257

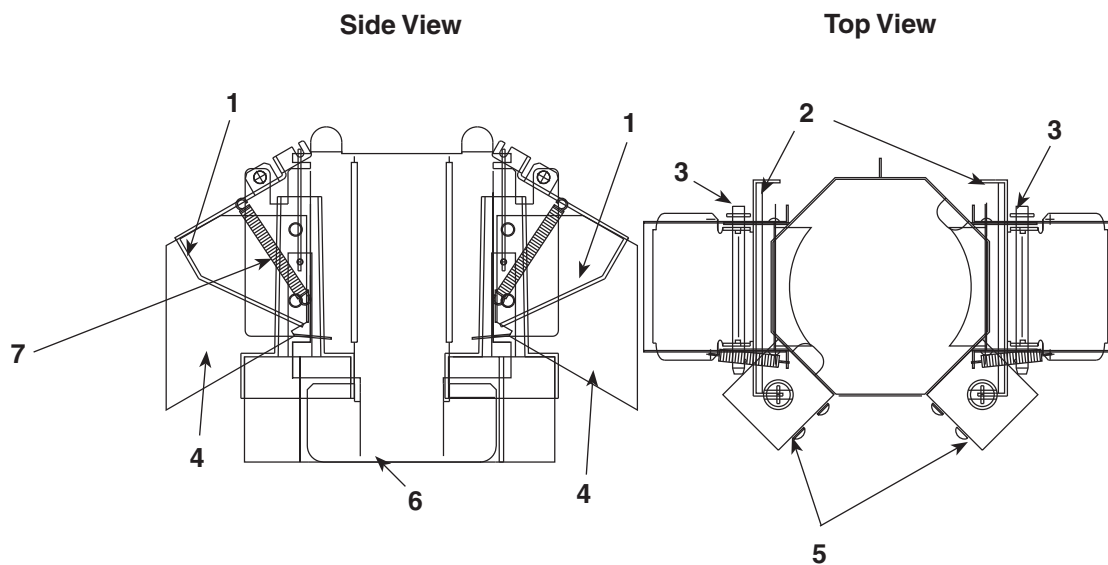

Reference #	Description	Part #
1	Gate, dispense	501955
2	Linkage pin, gate/solenoid	502096
3	Pin, quick release, 3" (77mm), gate and lever	501949
4	Chute, ice	501952
5	Solenoid	501961
Not shown	Boot, solenoid	502098
6	Dispense mechanism assembly	501948
7	Spring, dispense mechanism (1 per side)	501950
Not shown	Chute, focus	502459
Not shown	Lever, dispense	501953

Water bath

Order parts online
www.follettice.com

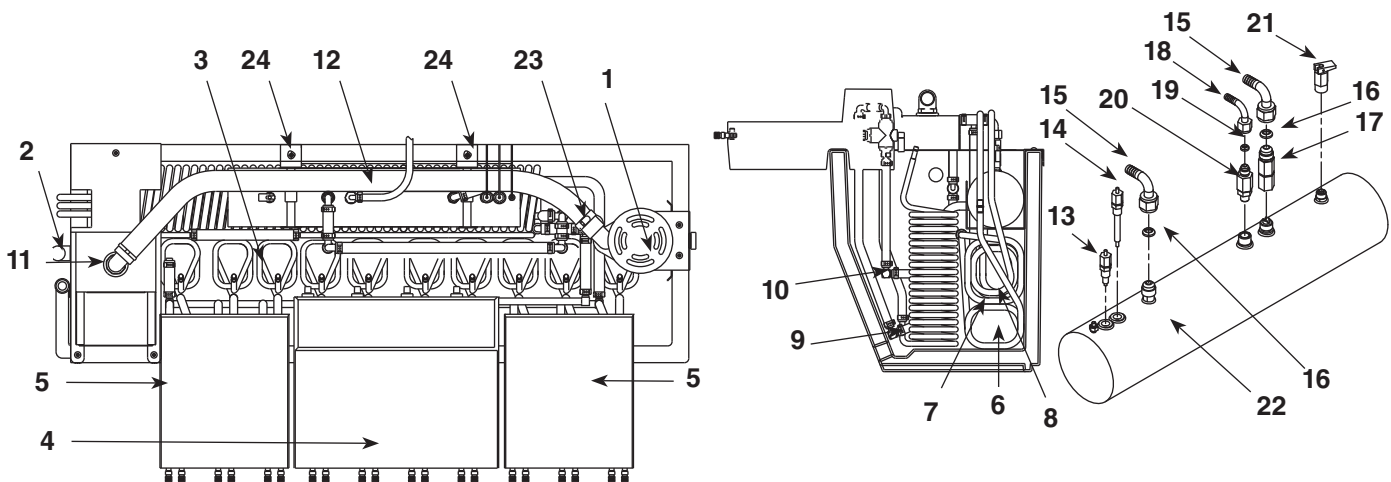

Reference #	Description	Part #
1	Pump, waterbath (includes mounting plate and elbow)	00111476
2	Elbow, overflow 1" (26mm) x 3/4 MPT	502465
Not shown	Elbow, clean out, drain, 3/8" (10mm) x 3/8 MPT	502466
3	Syrup coil	00125864
4	QuickCARB foam pack assembly	00127043
5	Foam pack assembly, 10 valve	00127068
Not shown	Foam pack assembly, 8 valve	00127076
6	Coil, carbonated water, 8 valve and 10 valve	00119560
7	Coil, carbonated, outer	00119578
8	Coil, non barb, inner	00119552
9	Manifold, carbonated water, 8 valve and 10 valve	00207540
10	Manifold, water 8 valve and 10 valve	00123141
11	Guide, ice bath, LH	00127084
Not shown	Guide, ice bath, RH	00127092
12	Tubing, vinyl, pump (order by foot, 3ft minimum)	501966
13	Water probe, high level (red)	00107409
14	Water probe, low level (black)	00107417
15	Elbow, 3/8" swivel (includes 00107433, 0107490)	00107425
16	Washer, seal, 3/8" (black)	00107433
17	Check valve, 3/8" (includes 00107433)	00107532
18	Elbow, 1/4" swivel (includes 00107466, 00106914)	00107458
19	Washer, seal, 1/4" (white)	00107466
20	Check valve, 1/4" (includes 00107466)	00107540
21	Pressure relief valve	00107482
22	Carbonator tank	00107508
23	Clamp, pump hose	500378
24	Bracket, carbonation tank	00106625

Electrical components

Order parts online
www.follettice.com

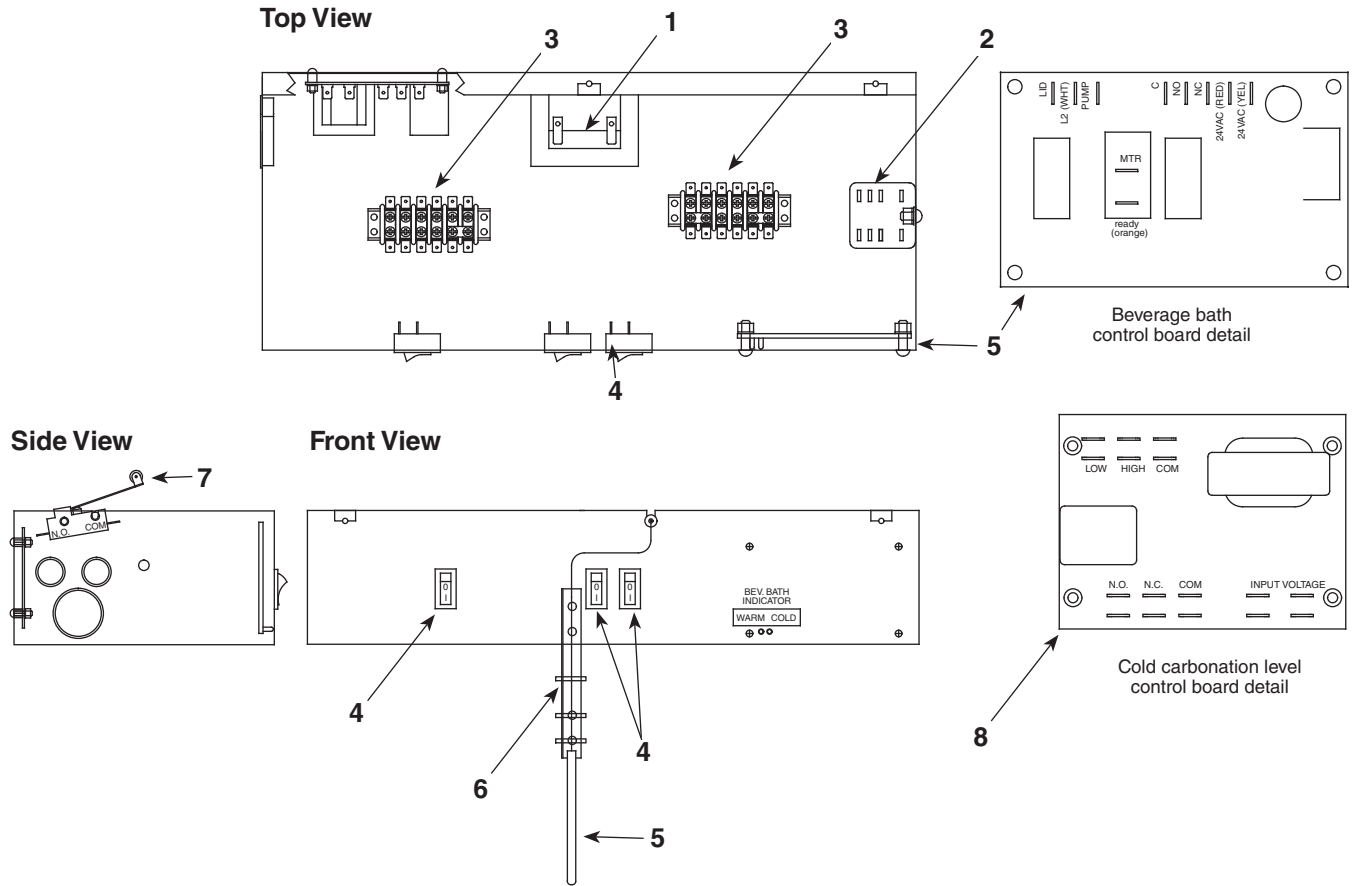

Reference #	Description	Part #
1	Transformer, 24V	502058
2	Relay, dispense	501826
3	Strips, terminal	502472
4	Switches (power and ice machine)	502209
5	Board, circuit and probe (one unit)	502473
6	Bracket, probe	00111484
7	Switch, safety	502511
Not shown	Switch, safety, drain pan assembly, LH unit	502500
Not shown	Switch, safety, drain pan assembly, RH unit	502501
Not shown	Switch, dispense, lever	502505
Not shown	Bracket, safety switch, drain pan, RH	502609
Not shown	Bracket, safety switch, drain pan, LH	502610
Not shown	Thermostat, bin level	500514
8	Control board, cold carbonation	00106708

This page intentionally left blank.

QuickCARB and RIDE are trademarks of Follett Corporation.
Chewblet is a registered trademark of Follett Corporation, registered in the US.



801 Church Lane • Easton, PA 18040, USA
Toll free (877) 612-5086 • +1 (610) 252-7301
www.follettice.com



00119628R04
3/12