

### Installation Guide

Please visit <https://www.follettice.com/technicaldocuments> for the Operation and Service manual for your unit

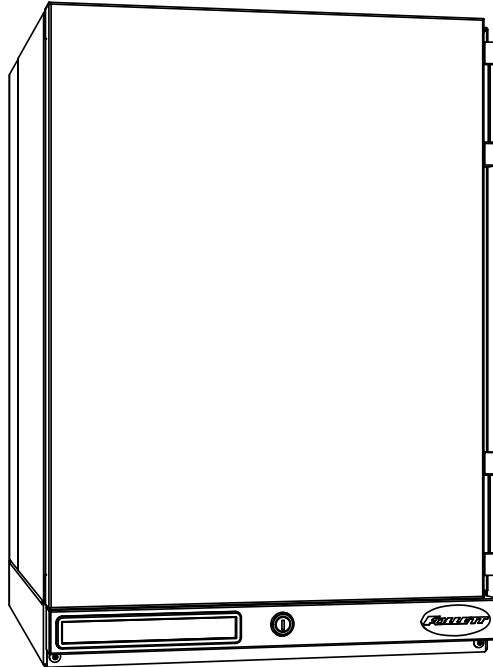

REFVAC2

## Welcome to Follett Products LLC

Follett Products equipment enjoys a well-deserved reputation for excellent performance, long-term reliability and outstanding after-the-sale support. To ensure that this equipment delivers that same degree of service, review this guide carefully before you begin your installation.

Should you need technical help, please call our Technical Service group at (877) 612-5086 or (610) 252-7301.

Please have your model number, serial number and complete and detailed explanation of the problem when contacting Technical Service.

## Getting Started

After uncrating and removing all packing material, inspect the equipment for concealed shipping damage. All freight is to be inspected upon delivery. If visible signs of damage exist, please refuse delivery or sign your delivery receipt "damaged." Follett Customer Service must be notified within 48 hours. Wherever possible, please include detailed photos of the damage with the original packaging so that we may start the freight claim process.

# Specifications

## Dimensions

REFVAC2	
Dimensions (external)	18.6" W x 24" D x 27.93" H (47 cm x 61 cm x 71 cm)
Dimensions (internal)	14.5" W x 10" D x 21.25" H (37 cm x 26 cm x 54 cm)
Shelf Size	13.75 W x 9 D (35 cm x 23 cm)
Capacity	1.8 cu ft (51 L)
Usable Space	1.21 cu ft (0.3 m <sup>3</sup> )
Weight (uncrated)*	87 lbs (39 kg)

\* Add 22 lbs/10 kg for packaging.

## Electrical Specifications

- 115 V, 60 Hz, 1 phase
- Full load: 1.8A
- Minimum circuit ampacity: 15A
- Connect to dedicated circuit, fuse or breaker
- Maximum size of branch circuit overcurrent device: 15A
- Follett recommends circuit be protected by GFCI.

## Refrigeration Specifications

Refrigerant	Charge Size (oz)	Maximum Design Pressures (psi)	
		High Side	Low Side
R134A	3.4	240	88

## Heat Rejection

- 190 BTU/hr (56 W) maximum

## Ambient Information



### CAUTION!

*The REFVAC2 are for indoor use only.*

	Optimum	Maximum
Air Temperature	≤80 F (27 C)	100 F (38 C)
Relative Humidity	60% max	

## Installation

### Locating the Refrigerator

Performance of REFVAC2 is affected by ambient temperature and location. To ensure proper performance, please refer to the following drawings and confirm that the clearance requirements are met. There is no clearance requirement for the back of the refrigerator so it can be placed against the wall.

**80 F (27 C) and 60% RH – located under overhanging cabinet or shelf with zero top clearance**

Requires 6" (15.3 cm) clearance on either right or left side

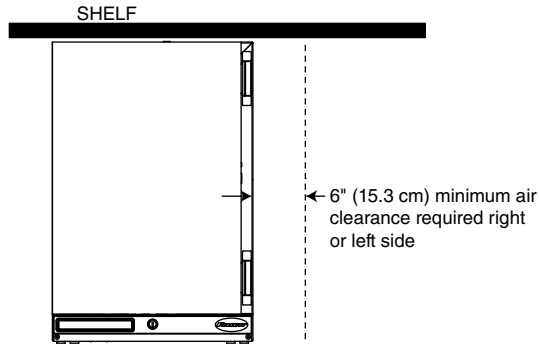

**80 F (27 C) and 60% RH – unrestricted top clearance location**

Requires 2" (5.1 cm) clearance on both sides and unrestricted top clearance (12" (30.5 cm) min above unit)

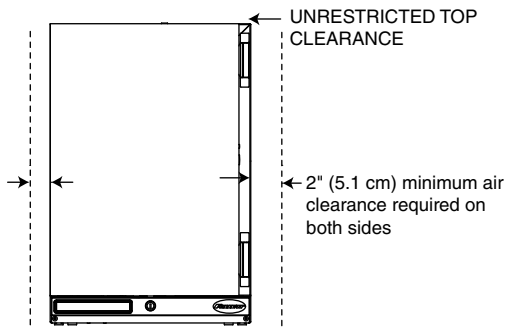

**100 F (38 C) – maximum temperature location with zero top clearance**

Requires 6" (15.3 cm) clearance on both sides

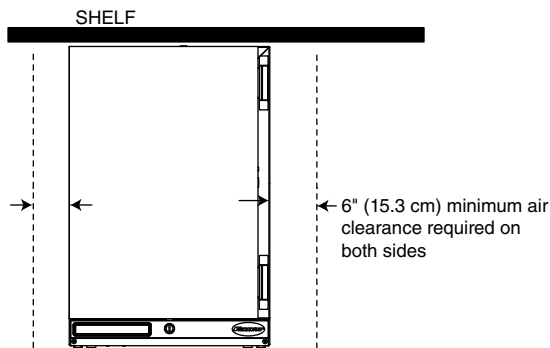

## Installing Shelves

1. Remove shelves and shelf brackets packed inside refrigerator. (If ordered, find additional shelf accessory in separate box.)
2. Install shelf brackets in pilasters (insert top tab, squeeze and push in lower tab) (**Fig. 1**).

Fig. 1

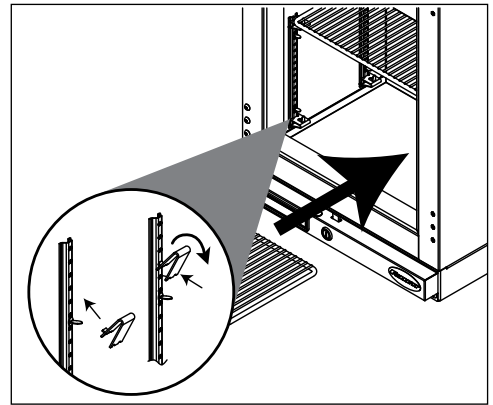

## Installing Glycerine Solution in Product Simulation Bottle

(glycerine not included - P/N00959296)

### **ATTENTION INSTALLER**

- It is imperative that the top/bottom probe bottle be filled with a solution that your facility uses to ensure proper operation of unit.
- Units are equipped with a third-party monitor installation port. Customers are required to refer to CDC Vaccine and Handling Toolkit ([cdc.gov](http://cdc.gov)) for proper placement of the probe within the cabinet to ensure proper performance.
- NSF 456 requires the temperature display probe (P4-RTD1 in REF12, REF20/25, FZR20/25, and REF45 models) to be replaced or recalibrated. Follett recommends replacement/recalibration 12 months from the original date of calibration on the Certificate of Traceability supplied with your equipment at the time of purchase. Recalibration or purchasing a new calibrated probe is not covered by the original equipment warranty. To purchase a new Probe with Certificate of Traceability, please contact our Parts Department @ 1-877-612-5086 or [partsales@follettice.com](mailto:partsales@follettice.com)

1. Remove the bottle from the bracket located in the upper left side of the refrigerator (**Fig. 2**).
2. Remove the top and fill the bottle with a 50/50 solution of glycerine and water.
3. Replace the top (and probe).
4. Reinsert bottle into the bracket.
5. Plug in the refrigerator and return the power switch to ON (**Fig. 3**).

Fig. 2



Fig. 3

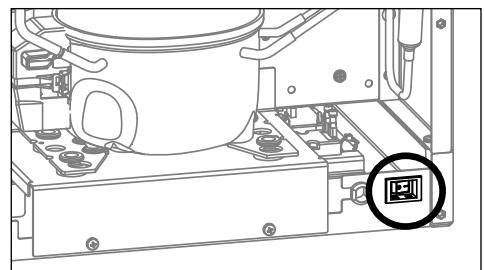

## Battery Backup (KP models only)

1. Provide power to the unit and turn the power switch to the **ON** position.
2. Open the door using the keypad lock and prop the door open so it doesn't close during the battery installation.
3. Turn power switch to the **OFF** position or unplug the unit from the power supply.
4. Remove the two screws (**Fig. 4.1**) on the front panel at the bottom of the unit.
5. Remove the front panel.

**Note: Take care when removing, some wires are connected to the front panel (Fig. 4.2).**

6. Find the battery pack on the right-hand side of the front panel.
7. Pull the battery pack and the battery connector away from the hook and loop patch on the front panel (**Fig. 4.3**).
8. Connect the battery connector with the black and red wires to the top of the battery pack.
9. Place the battery pack back in place firmly on the hook and loop patch.
10. Re-install the front panel.
11. Close the door.
12. Test operation of the keypad lock while the power to the unit is **OFF** to confirm back-up battery connection.
13. Turn the power switch **ON** or plug the unit back into the power supply.

Fig. 4

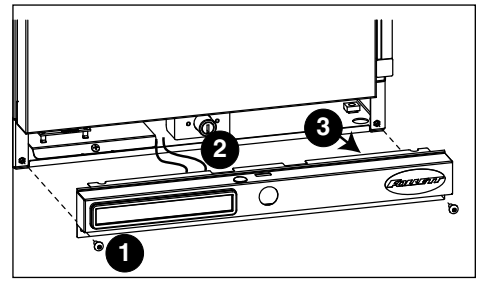

## Reversing the Door Swing – Optional



### **WARNING!**

*For protection, safety goggles (and/or face shield) should be worn when removing and/or installing the hinge spring.*

1. Use flat screwdriver to carefully remove hinge covers (**Fig. 5**).

Fig. 5

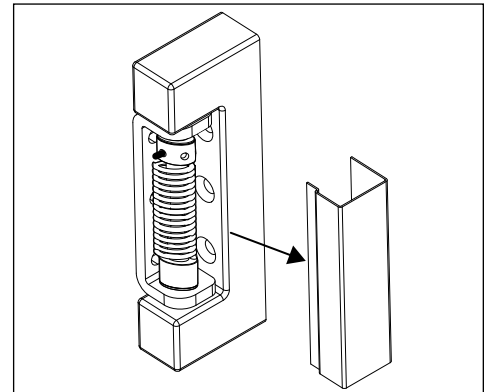

2. Using a small Phillips screwdriver, allen key or drift pin, rotate top of spring assembly (counter-clockwise for right-hand hinged doors) **(Fig. 6.1)** to remove the pin **(Fig. 6.2)**.
3. Relieve torque on the spring.

**Fig. 6**

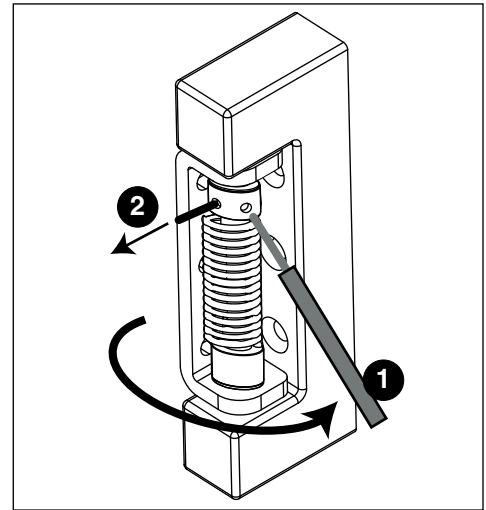

4. With a flat-head screwdriver, simultaneously push down and pry the top of the spring from out of the top of the hinge **(Fig. 7)**.

**Fig. 7**

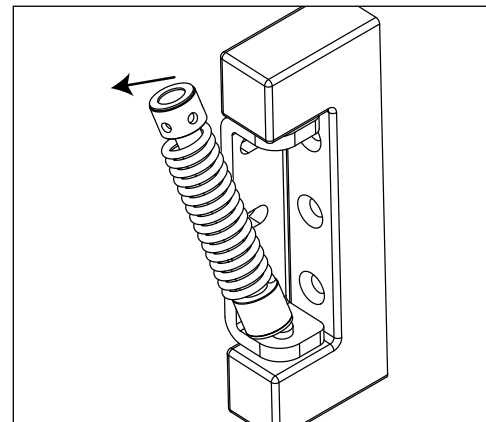

5. Support door and remove screws attaching hinge to refrigerator cabinet and remove the door **(Fig. 8)**.
6. Cover hinge screw holes with screws removed from opposite side of door and door frame.

**Fig. 8**

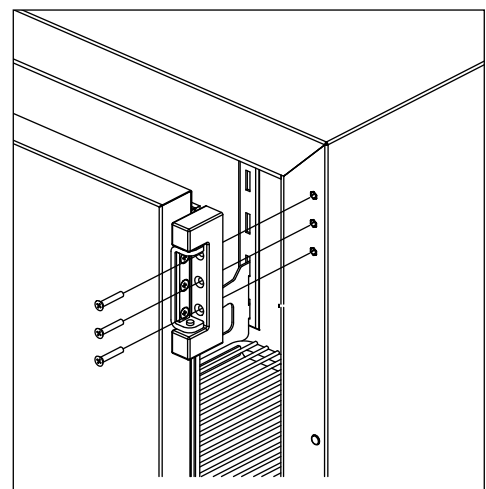

7. Remove screws holding lock strike-bracket at "bottom" inside of door (**Fig. 9.1**).
8. Remove screws from inside of door "top" and install bracket.
9. Plug "bottom" holes with retained screws and install lock strike-bracket to "top" inside of door (**Fig. 9.2**).
10. Reverse door 180° so that lock strike-bracket is on the bottom inside of door (**Fig. 9.3**).

**Fig. 9**

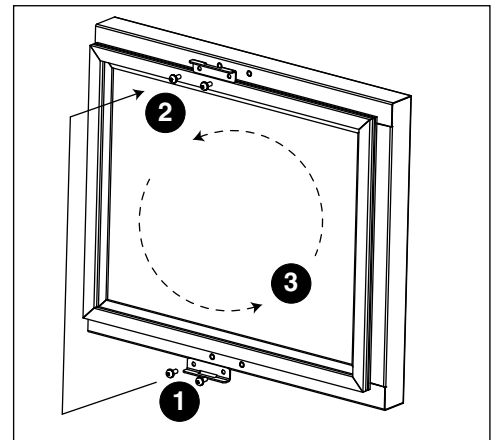

11. Reinstall the door on the opposite side of the doorframe. Adjust if needed.
12. Reinstall screws (torqued to 25 in-lbs) (**Fig. 10**).

**Fig. 10**

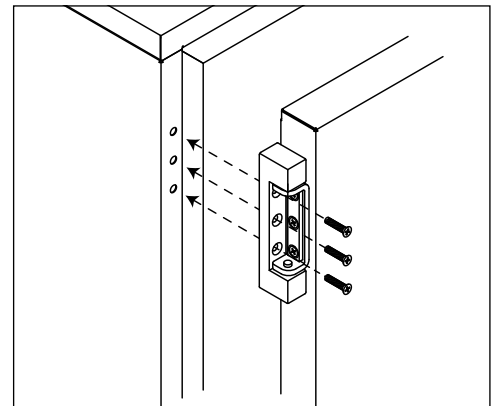

13. Insert bottom of spring kit onto bottom hinge pin (**Fig. 11**).

**Fig. 11**

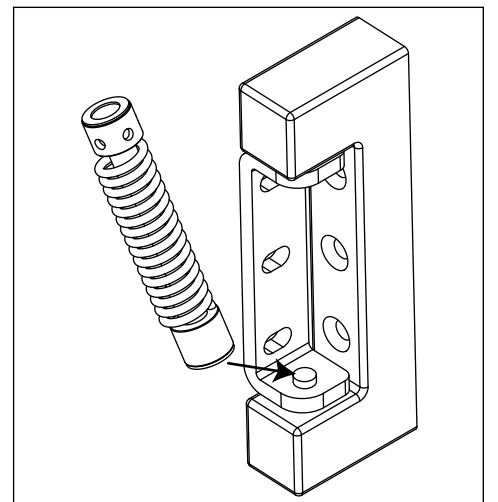

14. Insert tool as shown and press down on both sides of tool (Fig. 12.1) to compress spring kit, then insert top of spring kit onto top hinge pin (Fig. 12.2).

Fig. 12

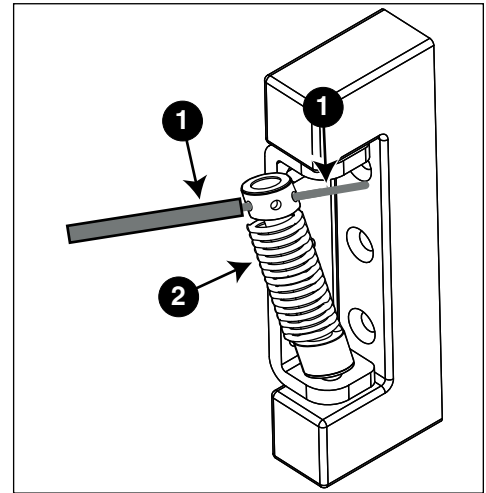

Fig. 13

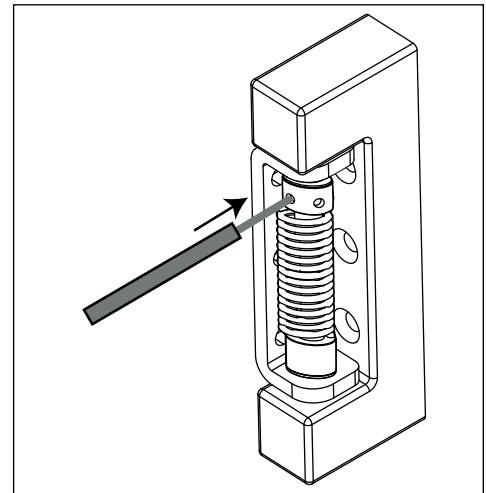
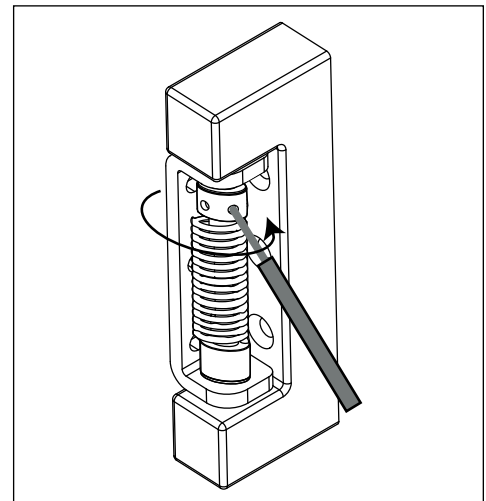

Fig. 14



### Adjusting Hinge Closure Force

1. Remove the tool and insert it (Phillips screwdriver, Allen key, drift pin) into hole nearest the hinge bracket (Fig. 13).
2. Rotate top of spring counter-clockwise to increase the spring torque (Fig. 14).



3. Insert pin into an open hole nearest the hinge bracket (**Fig. 15.1**), and remove the tool used to torque the spring (**Fig. 15.2**).
4. Repeat Steps 2 and 3 until desired closure force is achieved.



**CAUTION!**

*Do not overtorque the spring unnecessarily. Minimum closure force should close door when door is opened 1" (2.5 cm).*

5. Reinstall hinge cover (**Fig. 16**).

**Fig. 15**

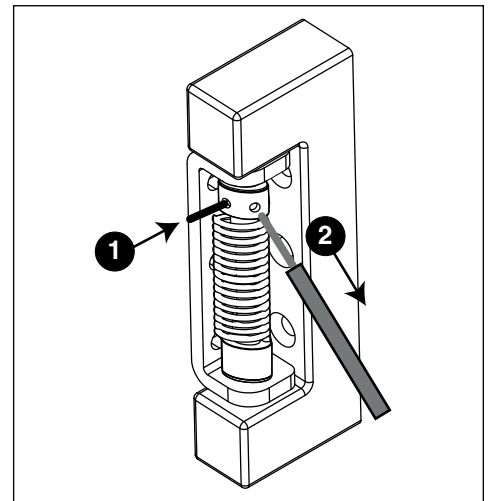

**Fig. 16**

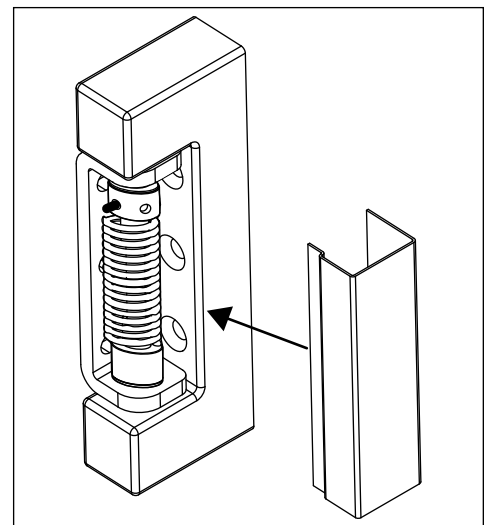

**Fig. 17**

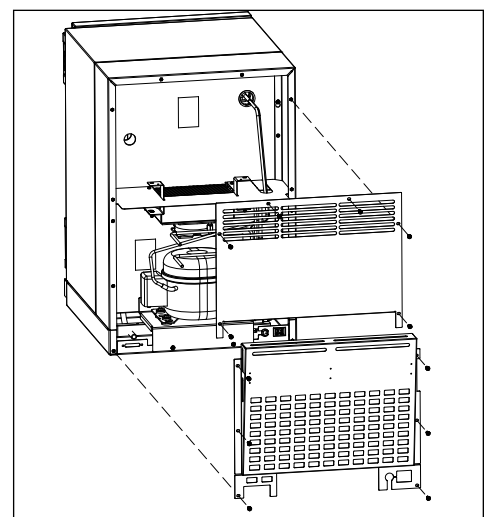

### Installing Third-party Temperature Probe

Facilities using a third-party alarming and/or temperature monitoring system need to install the third-party probe in the refrigerator. Follett recommends removing any stored product before performing this procedure.

1. Move the power switch on lower rear panel to OFF and unplug the refrigerator.
2. Remove the rear panel of the refrigerator (**Fig. 17**).
3. Open front door of refrigerator and remove shelf/shelves, if installed, for better access.

4. From inside the refrigerator, push and fold the perforated cut out located on the inside, upper-right hand corner (**Fig. 18**).
5. Use a long screwdriver or drill to create a hole (up to 1" (25.4 mm) diameter) through the exposed foam insulation.
6. From inside the refrigerator, feed non-probe end of wire through opening (**Fig. 19**).
7. Secure probe to interior cabinet wall to avoid product interference.
8. Gently pull on non-probe end of wire to remove slack from inside of refrigerator.
9. Use Permagem\* or equivalent sealant to replace foam insulation (removed in Step 5) to ensure proper performance of refrigerator.
10. Remove any debris that may have fallen into the drain pan or condensor area.
11. Route non-probe end of wire through appropriate ventilation hole in refrigerator rear panel.
12. Reinstall the rear panel.
13. Connect non-probe end of wiring to monitoring device.
14. Plug in the refrigerator and return the power switch to ON.

**Fig. 18**

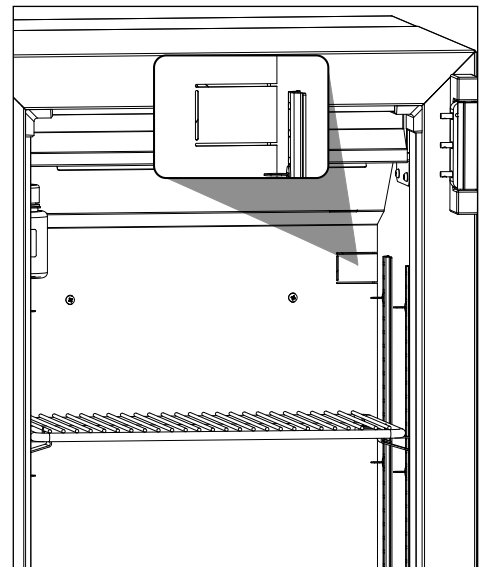

**Fig. 19**

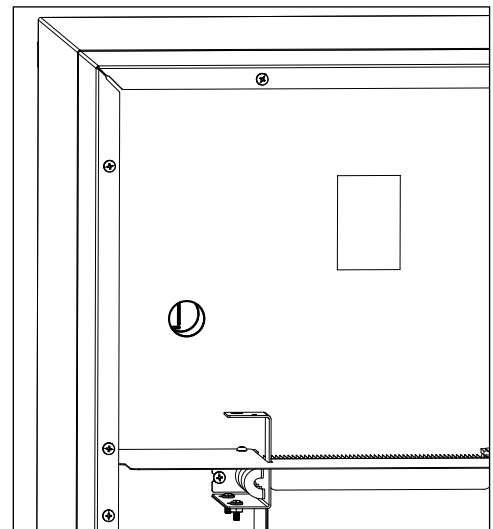

\* Permagem is a registered trademark of the Presstite Engineering Company.

## Cleaning

### **CAUTION!**

Use only non-chlorine-based cleaners. Use of cleaners containing chlorine can cause staining and pitting of the stainless steel

#### Interior

Using a sponge or soft cloth, clean unit with a non-abrasive, non-chlorinated, all-purpose detergent.

#### Exterior

Wipe exterior with a soft cloth in the direction of grain as needed. Stainless steel polish may be used to enhance the finish of the unit.

## Annual Cleaning

Removal of dust and other particulates from air intake areas and the condenser is important for proper operation. Under certain conditions, some environments with large amounts of dust may require more frequent cleaning.

1. Move the power switch on lower rear panel to OFF and unplug the refrigerator.
2. Remove rear panel (**Fig. 20.1**).
3. Clean drain pan (**Fig. 20.2**) with a non-abrasive, non-chlorinated all-purpose detergent.
4. Use a vacuum cleaner with brush attachment to clean condenser, compressor motor, and related parts.
5. Reinstall rear panel.

**Fig. 20**

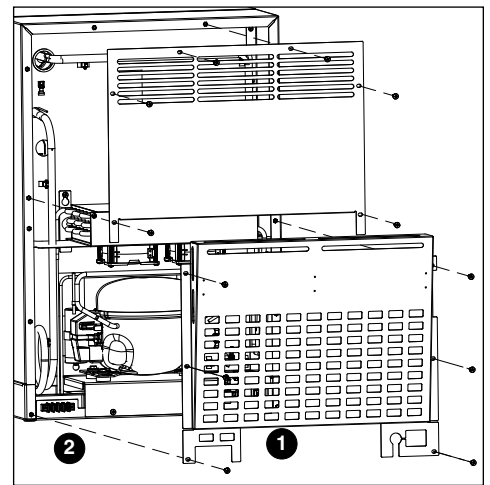

## Operation

The temperature control board and probe indicate when the refrigeration system is required to turn on and off.

The refrigeration system removes heat from the cabinet interior and rejects it to the surrounding room air. When the cabinet interior temperature rises above the controller cut-in temperature, the controller turns the refrigeration system on. The controller energizes the evaporator fan and solid-state control relay which energizes the condensing unit. The compressor uses a current-style starting relay and a starting capacitor to start the compressor motor.

When the cabinet interior temperature falls below the controller cut-out temperature, the controller turns the refrigeration system off. The controller contacts reopen, which de-energizes the evaporator fan motor and solid-state control relay which de-energizes the condensing unit (compressor and condenser fan motor).

Any accumulated frost on the evaporator coils melts during the off cycle. The condensate drains out of the unit to the condensate tray to the left of the condensing unit. The heat from the condensing unit evaporates any condensate in the drain pan.

## Temperature Control

The temperature control system is preset by the factory to maintain a cabinet temperature of 3.5 to 6.5 C (38.3 to 43.7 F). If desired, the set-point temperature can be raised as high as 10 C (50 F) by following the instructions in *Controller Operation* for changing the temperature set point. The 2.2 C differential will be maintained regardless of the controller set point.

## Automatic Defrost

REFVAC Series refrigerators do not require manual defrosting. The unit defrosts automatically when the condensing unit is in the OFF cycle.

Any accumulated frost on the evaporator coil melts during the OFF cycle. The condensate drains to a plastic drain pan mounted below the condensing unit. The heat from the condensing unit evaporates any condensate in the drain pan.

## Controller Operation

In normal operation, the controller displays product temperature in degrees C (default) or user-selected degrees F.

The controller is pre-programmed with a 5.4 C (41.7 F) set point. **COMP** displays when the compressor is running. If this set point does not meet your specific application needs, instructions for changing the set point are found below.

**Note:** Follett presets its refrigeration system to hold product temperature at approximately 5.4 C (41.7 F). If you are using this in a food service application, and installing in accordance with NSF, you must set the control set-point to 3.3 C (38 F). This will deliver a product temperature below the 4.4 C (40 F) NSF requirement.

## Controller Display

The controller display will show the product/bottle temperature in degrees C or degrees F as selected by the user except when the unit is in an alarm.

The controller has system indicators above the temperature display to let you know when: the compressor is energized (**COMP**), the evaporator fan is energized (**FAN**) or the unit is in defrost (**DEF**).



To display temperature Set-point		
Step	Input	Display
1	Press and release <b>SET</b>	Current set-point temperature will display for approximately 5 seconds. Display will return to current product temperature.

To change temperature Set-point		
Step	Input	Display
1	Press and hold <b>SET</b> for 3 seconds	Set-point will flash.
2	Press <b>UP</b> or <b>DOWN</b> arrows to desired set-point	New temperature set-point will flash on the display.
3	Press and release <b>SET</b> to accept	Product temperature will display.

## Controller Security

The controller can be locked so that the set-points in the controller cannot be changed.

1. To lock, press **UP** and **DOWN** arrows simultaneously until **LOC** appears (approximately 5 s).
2. To unlock the controller, press up and down arrows simultaneously until **UNL** appears. Changes are only accepted when the controller is unlocked.

## Changing Temperature Display from C to F

1. Press **SET** and **UP** arrow simultaneously until **L1** is displayed.
2. Press the **UP** arrow until **UNT** is displayed. Press **SET** then use the **UP** and **DOWN** arrows to change the temperature display from C to F. Press **SET** to accept. The display will return to the temperature in approximately 10 s.

## Changing Temperature Display from Decimal to Integer

1. Press **SET** and **UP** arrow simultaneously until **L1** (first level menu) is displayed. Release.
1. Press **SET** and **UP** arrow simultaneously until **L2** (second level menu) is displayed.
2. Press the **UP** arrow until **rES** is displayed. Press **SET** then use the **UP** and **DOWN** arrows to select **Int** (integer) instead of **Dec** (decimal). Press **SET** to accept.

## Sleep Function

Press the **SLEEP** button to blank the display, or press any button to wake the display. If the unit goes into an alarm, the display will wake to display the alarm.

## Minimum and Maximum Temperature Function

Records the highest and lowest temperatures logged by the probe selected to be displayed. Default display probe is P3 (product simulation bottle probe).

### High and low log display

1. Press the **UP** arrow to display the highest temperature recorded since last reset or power cycle.
2. Press the **DOWN** arrow to display the lowest temperature recorded since last reset or power cycle.

### Reset high and low log

1. Press **UP** or **DOWN** arrow until recorded temperature is displayed.
2. Press and hold **SET** until **RST** is displayed.

## Alarming Functions

### Set high and low alarms

1. Press and hold **SET** and **UP** arrows simultaneously until **L1** is displayed. Use the **UP** and **DOWN** arrows to navigate parameters.
2. The **low** temperature alarm parameter is **AIL**. Once the parameter is displayed, press **SET** to display the low alarm temperature. The alarm temperature will flash on the display. Use the **UP** and **DOWN** arrows to set the alarm temperature. Press **SET** to accept.
3. The **high** temperature alarm parameter is **AIH**. Once the parameter is displayed, press **SET** to display the high alarm temperature. The alarm temperature will flash on the display. Use the **UP** and **DOWN** arrows to set the alarm temperature. Press **SET** to accept.

**Note: VAC models have the alarms factory preset to 2 C (35.6 F) and 8 C (46.4 F).**

### Start-up alarm delay

The refrigerator unit has a 120 minute time delay between when the unit is energized to when the temperature alarms become active. This delay can be change in parameters in the controller under **Alarm Startup Delay (ASd)**.

### Mute the Alarms

The mute button is used to temporarily mute the audible alarm for 10 minutes. If the alarm condition of the unit has not changed in 10 minutes, then the alarm will sound again.

### Alarm acknowledgement and alarm Reset

The alarm will need to be acknowledged after the alarm condition has been resolved, before the alarm will reset. To acknowledge the alarm press and hold set until the RST is displayed.

### Probe calibration

- NSF 456 requires the temperature display probe (P4-RTD1 in REF12, REF20/25, FZR20/25, and REF45 models) to be replaced or recalibrated. Follett recommends replacement/recalibration 12 months from the original date of calibration on the Certificate of Traceability supplied with your equipment at the time of purchase. Recalibration or purchasing a new calibrated probe is not covered by the original equipment warranty. To purchase a new Probe with Certificate of Traceability, please contact our Parts Department @ 1-877-612-5086 or partsales@follettice.com

The temperature probes can be calibrated from **-9.9 to +9.9**. The calibration is in the second level menu under **P1C** (control probe) **P3C** (Alarm).

### Alarm Codes

When the unit senses an alarm, the display will flash the following codes.

Value	Description
HA1	Temperature is above the High Alarm #1 set point.
LA1	Temperature is below the low Alarm #1 set point.
HA2	Temperature is above the High Alarm #2 set point.
LA2	Temperature is below the Low Alarm #2 set point.
Lob	Low battery alarm.

### Error Codes

Value	Description
P1-P8	Controller is not sensing the probe.
F9	Error saving new parameter values to permanent storage.
F10	Incomplete model configuration.
F11	Number/membrane is sticking.
F21	Key shorted on user interface.
F22	Communication error with user interface.
F23	Communication error with Machine Control.

### Alarming Contacts – *Optional Accessory*

This unit can be equipped with dry contacts that may be connected to a 3rd party monitoring system. The dry contacts would have a Common, a Normally Open and a Normally Closed connection point. By default, Alarm Relay 1 is set to activate with any of the following alarms: Alarm 1 High temp, Alarm 1 Low temp, Door Open Alarm, and Power Loss Alarm.

**Fig. 21 - Rear Panel Connections (when installed)**

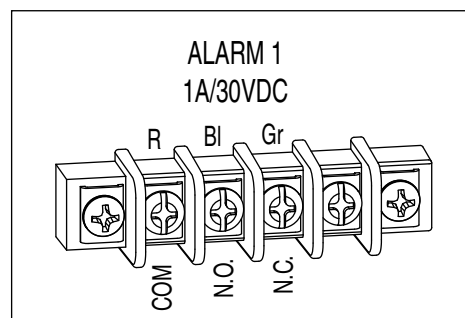

### Advanced Settings

The refrigerator can be further customized through the first level (L1) and second level parameters (L2) in the chart below.

1. Press and hold **SET** and **UP** arrows simultaneously until **L1** is displayed.
2. Use the **UP** and **DOWN** arrows to navigate the parameters. When the desired parameter is displayed, press **SET**.
3. Use the **UP** and **DOWN** arrows to navigate the sub menu of the parameter. Press **SET** to accept and the display will return to the parameter list (after 30 seconds the display will return to the temperature display).

Parameter	Display	Description
Beeper Function	bPr	Controls the audible beeper function on the controller. <b>Off, All, door, Alarm, Error.</b>
Beeper Volume	bPu	Sets the volume of the beeper: <b>0</b> (minimum) to <b>10</b> (maximum).
Button Clicks	btc	Sets if a beep should sound each time a button is pressed. <b>Yes</b> or <b>No</b> .
Sleep Function	SLP	Determines if sleep function activated from the panel. <b>Yes</b> or <b>No</b> .
Sleep Timer	SLt	Amount of time before the screen blanks automatically. <b>0 s</b> to <b>600 s</b> .
Alarm1 High Temp	A1H	High temperature to activate alarm1. User set point to 121 C (250 F).
Alarm1 Low Temp	A1L	Low temperature to activate alarm1. User set point to -46 C (-50 F).
Alarm1 Probe	A1P	Probe for Alarm. <b>P1</b> (cabinet air), <b>P3</b> (simulation bottle).
Units	unt	Display temperatures in degrees C or F. <b>F</b> or <b>C</b> .

1. Press and hold **SET** and **UP** arrows simultaneously until **L1** is displayed.
2. Press and hold **SET** and **UP** arrows simultaneously again until **L2** is displayed.
3. Use the **UP** and **DOWN** arrows to navigate the parameters. When the desired parameter is displayed, press **SET**.
4. Use the **UP** and **DOWN** arrows to navigate the sub menu of the parameter. Press **SET** to accept and the display will return to the parameter list (after 30 seconds the display will return to the temperature display).

Parameter	Display	Description
Alarm1 Delay	A1d	Alarm1 delay before sounding. <b>0</b> to <b>60</b> minutes
Alarm1 Function	A1F	Defines the action taken when Alarm2 is activated. <b>NO</b> (normally open), <b>NC</b> (normally closed), <b>R1</b> (activate relay), <b>R2</b> (not used), <b>DIS</b> (disable).
Alarm1 Reset	A2r	Temperature difference to reset alarm1. <b>0</b> to <b>10</b> degrees.
Alarm2 Delay	A2d	Alarm1 delay before sounding. <b>0</b> to <b>60</b> minutes.
Alarm2 Function	A2F	Defines the action taken when Alarm2 is activated. <b>NO</b> (normally open), <b>NC</b> (normally closed), <b>R1</b> (activate relay), <b>R2</b> (not used), <b>DIS</b> (disable).
Alarm2 Reset	A2r	Temperature difference to reset alarm1. <b>0</b> to <b>10</b> degrees.
Alarm Ring back	Arb	Defines the time delay until the alarm will resound. <b>0</b> to <b>120</b> minutes
Alarm Startup Delay	ASd	Defines the alarm delay during startup. <b>0</b> to <b>180</b> minutes.
Alarm Silencing	ASL	Determines if the alarms can be silenced or not. <b>Yes, No.</b>
Maintain Alarm	nAL	Determines if the alarm (1-3) should be maintained if the temperatures fall back into range. <b>Yes, No.</b>
Probe 1 Calibration	P1C	Offset value for probe 1 calibration. <b>-9.9</b> to <b>9.9</b> .
Probe 3 Calibration	P3C	Offset value for probe 3 calibration. <b>-9.9</b> to <b>9.9</b> .
Controller Parameter Reset	rSt	Reset to restore factory parameters.

## Follett Keypad Lock

### Default user passcode for first-time users

User Code 01 is factory set by default to **1 2 3 4 5 6**.

**Note: In order to continue using 1 2 3 4 5 6 as a default, user-selectable programming codes must be stored in slots 02 to 40.**

User Codes 02 to 40 do not have any codes set up and are available for user-programming.

Each time a button is pressed, a chirp will be heard.

### To Change the Master Code

The master code is needed to add or change the individual user codes. By default, the master code is set to **1 2 3 4 5 6**.

The master code is stored in User ID # 99.

1. Press **3 6 5**, the **\***, followed by the current Master Code, followed by **ENTER** (5 chirps will be heard).
2. Press **9 9**, followed by **ENTER**. (3 chirps will be heard).
3. Enter the new master code, followed by **ENTER** (3 chirps will be heard).
4. Re-enter the new master code, followed by **ENTER**. (5 chirps will be heard).
  - Pressing [**CANCEL**] at any point will cancel the routine.

### To Enter or Change a User Code

1. Press **3 6 5**, the **\***, followed by the Master Code, followed by **ENTER**. 5 chirps will be heard.
2. Enter the user ID (a two digit code from 00 to 40), followed by **ENTER**. 3 chirps will be heard.
3. Enter the new user code (4 to 6 numbers), followed by **ENTER**. 3 chirps will be heard.
4. Re-Enter the new User Code, Followed by **ENTER**. 5 chirps will be heard to acknowledge that a new code was entered.

Example: To enter a new user code of 4 4 3 3 5 5 for ID # 15

1. Press **3 6 5 \* 1 2 3 4 5 6 [ENTER]** (5 chirps will be heard).
2. Press **1 5 [ENTER]** (3 chirps will be heard).
3. Press **4 4 3 3 5 5 [ENTER]** (3 chirps will be heard).
4. Press **4 4 3 3 5 5 [ENTER]** (5 chirps will be heard).

The new code has been entered for the ID.



## To Delete a User Code

1. Press **3 6 5**, the **\***, followed by the Master Code, followed by **ENTER**. 5 chirps will be heard.
2. Enter the user ID to clear, followed by **ENTER** (3 chirps will be heard).
3. Press **3 3 5**, # (3 chirps are heard) (335 = DEL).
4. Enter the user ID to clear, followed by **ENTER** (2 chirps will be heard).
5. Press **3 3 5**, # (5 chirps are heard).

The code assigned to that user ID has been deleted. If an error is encountered, the control will beep continuously for 3 seconds. The Master Code stored in user ID 99 cannot be deleted.

Example: To delete the user code in ID 15:

1. Press **3 6 5 # 1 2 3 4 5 6** [**ENTER**] (5 chirps will be heard).
2. Press **1 5** [**ENTER**] (3 chirps will be heard).
3. Press **3 3 5**, # (3 chirps will be heard) (335 = DEL).
4. Press **1 5** [**ENTER**] (2 chirps will be heard).
5. Press **3 3 5**, # (5 chirps will be heard).

# Wiring Diagram

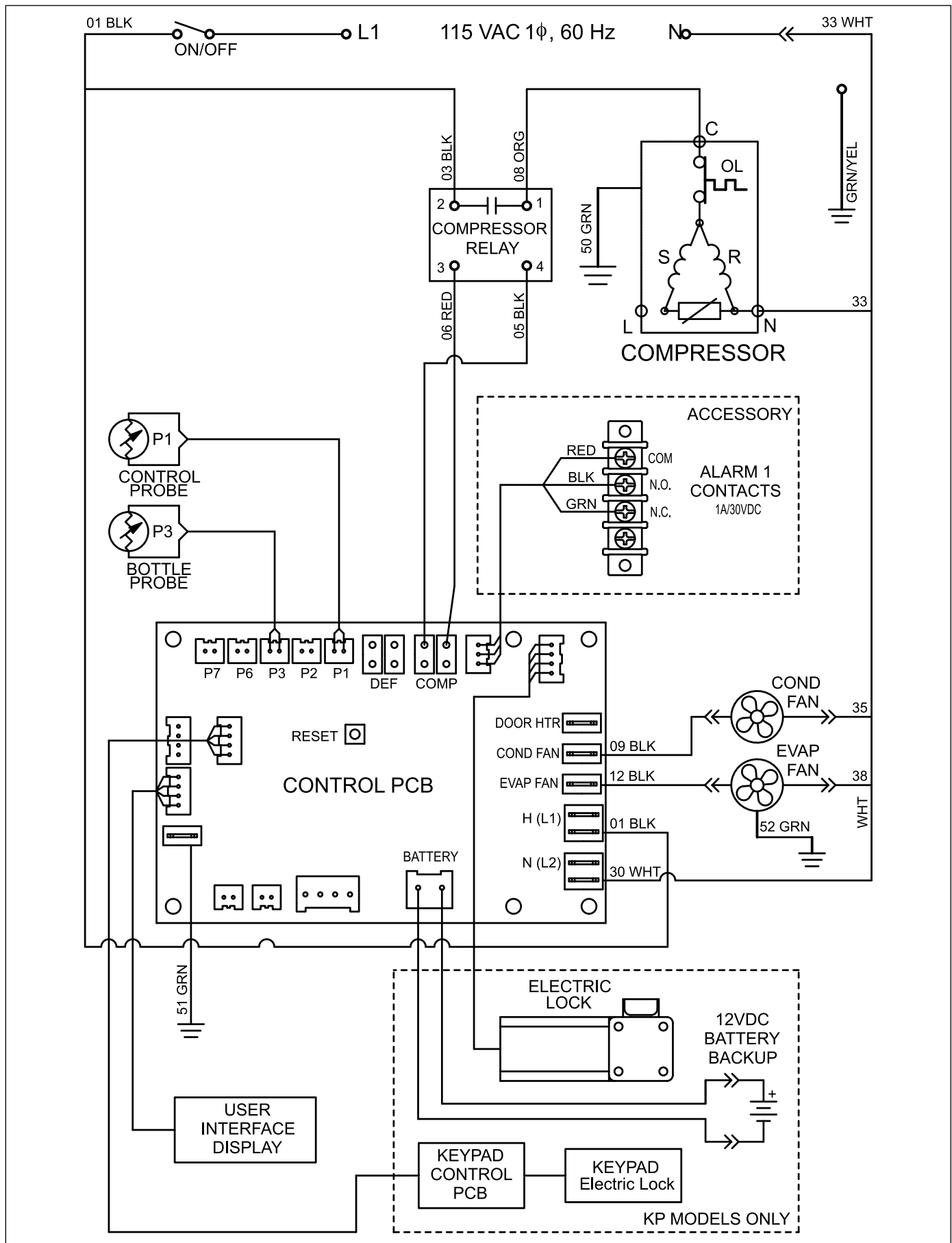

## Refrigeration System Diagram

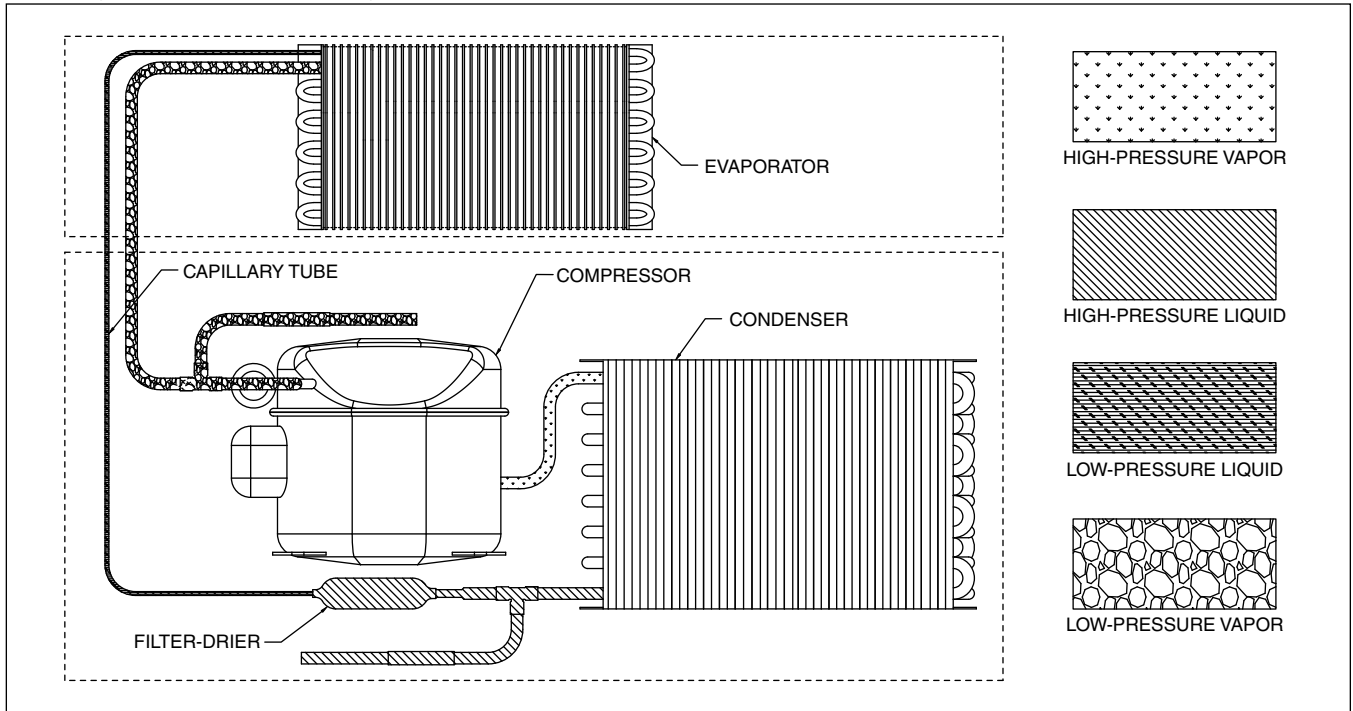

## Compressor Information

Danfoss model	TL2.5
Run load amps (RLA)	2
Lock rotor amps (LRA)	16
Ohms start winding to common	4.9
Ohms run winding to common	5.3
Ohms start winding to run winding	10.2

# Refrigerator Troubleshooting

## Before calling for service

1. Check that unit is plugged in.
2. Test outlet with another appliance to verify power.

## Troubleshooting Matrix

Sympton	Possible Cause	Solution
Refrigerator does not operate (no components run).	Power switch faulty or in OFF position; loose connection.	Turn power switch to ON; check switch and connections.
	Refrigerator not plugged in.	Connect plug.
	No power to cord.	Restore power.
	Temp controller not energizing components.	Check controller contact terminals for power. Replace controller if needed.
	Probe not sensing set point temperature.	Replace controller and/or probe.
Compressor does not run.	Thermal overload open or defective.	Allow to cool or replace.
	Capacitor and/or relay defective.	Replace as required.
	Compressor defective.	Replace compressor.
Evaporator fan motor does not run.	Defective fan motor.	Replace fan motor.
Refrigerator does not shut off.	Controller not sensing cut-off temperature.	Replace controller and/or probe.
	Controller keeping refrigeration system energized.	Replace controller.
Refrigerator does not maintain temperature (all components run).	Condensor or evaporator coil needs cleaning.	Clean coils.
	Faulty door gasket.	Replace door gasket.
	Excessively high ambient or indadequate air clearance.	Maximum recommended ambient is 100 F (38 F).
	Refrigerant leak.	Locate and repair leak.
	Incorrect refrigerant charge.	Recover, evaluate and weigh in correct charge.
	Plugged capillary tube.	Replace capillary tube and filter drier.
	Inefficient compressor.	Consult technical services.

**If problems persist after following this basic troubleshooting guide, call Follett technical service group at (877) 612-5086 or +1 (610) 252-7301.**

## Warranty Registration and Equipment Evaluation

Thank you for purchasing Follett® equipment. We hope you find that our equipment meets or exceeds your expectations, as our goal is to deliver high value products and services that earn your complete satisfaction!

Please review the enclosed installation and operations manual. It is important that the installation be performed to factory specifications, so your equipment operates to its maximum efficiency.

Follett LLC will not be liable for any consequential damages, expenses, connecting or disconnecting charges or any losses resulting from a defect of the machine.

For full warranty details, visit our website [www.follettice.com/productwarranties](http://www.follettice.com/productwarranties).

Warranty registration and equipment evaluation is important to help us keep track of our equipment and to record the machine's performance. We request that you register Follett equipment warranties on our website [www.follettice.com/support](http://www.follettice.com/support) and choose Warranty Registration and Equipment Evaluation. It's simple to do; please take a moment to register today. There is also space on the form to provide us with comments and feedback. Please let us know about your experience so we can capture it for our continuous improvement efforts.

We pride ourselves on producing outstanding equipment and we work hard to back it up with outstanding customer and technical support. Please let us know what else we can do to assist you. We would be happy to answer your questions.

FOLLETT and FOLLETT HEALTHCARE are registered trademarks of Follett Products, LLC, registered in the US.



801 Church Lane • Easton, PA 18040, USA  
 Toll free (877) 612-5086 • +1 (610) 252-7301  
[www.follettice.com/healthcare](http://www.follettice.com/healthcare)

01441468R00  
 © Follett Products, LLC 6/22