

Maestro Plus™

E 414 series ice machine for healthcare applications

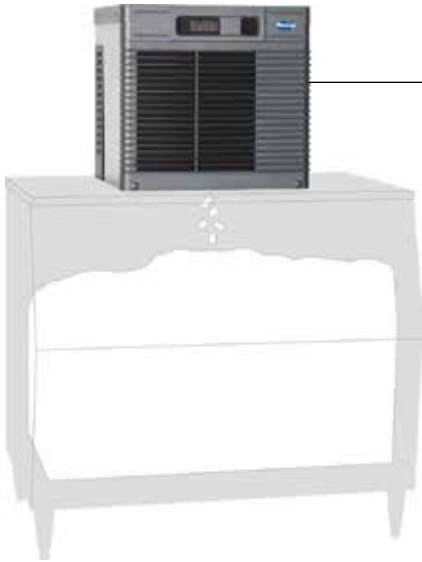

Model MCE414ABT shown



Features

Maestro Plus ice machine with up to 193 kg (425 lb) daily production of consumer-preferred Chewblet® or flake ice.

High performance Maestro Plus ice machines

- compact, reliable ice machine for top mount installation
- stainless steel evaporator, auger and top bearing
- oversized, heavy duty, tapered roller bearing ensures long low-maintenance life
- automatic self-flushing of ice machine for superior scale control
- no noisy harvest cycles means quiet ice production

Lower utility bills

- energy-efficient, no costly defrost cycles
- meets 2018 Department of Energy regulations
- 40% less water than comparable capacity cube machines

Maintenance and service benefits

- cleaning and sanitizing of entire machine takes less than 1 hour
- LED control board provides at-a-glance machine status

Flake ice (MFE models) is the required ice for clinical labs, rehab and medical research

- high surface area of flake ice chills quickly, maintains samples at desired temperature
- holds test tubes and lab vials securely, even when ice is melting
- molds well in ice bag and rehab applications for best skin contact and swelling control

Consumer-preferred Chewblet ice (MCE models)

- chewable, compressed nugget ice is preferred over cubes¹
- available with approximately 1.00" (2.54 cm) long standard Chewblet ice or optional 3/8" (0.95 cm) long Micro Chewblet™ ice
- more reliable dispensing than nugget or pellet ice
- slow melting, maintains drink temperature and quality, comparable to cubes
- higher displacement than cube ice

Installation flexibility

- Top kits allow ice machine to be top mounted on most ice and beverage dispensers
- Top kits install without any alteration to dispenser (kit includes stainless steel top)
- compatible with over 20 of Follett's ice storage bins

Warranty

- 3 years parts and labor, 5 years compressor parts²

¹ Consumer study conducted by independent agency Roper ASW.

² Refer to price list for additional warranty information.

Model configurations				
Ice type	For use with ¹	Condenser	V/Hz ²	Item number
Flake	ice storage bin	air	230/50	MFE414ABT
Chewblet®	ice storage bin	air	230/50	MCE414ABT
	ice and beverage dispenser (by others)	air	230/50	MCE414AHT
Micro Chewblet	ice storage bin	air	230/50	MME414ABT

¹ Ordered separately.

² Alternate voltage not for use in the United States.

Accessories

Water filters (refer to form# 9905)

Additional Maestro Plus accessories (refer to price list)

Specification for bin top mount ice machines

W1 Width	57.6 cm (22.70") fits on 22.00" wide dispensers or bins
D1 Depth, ice machine	61.6 cm (24.25")
D2 Depth, bin door	80.0 cm (31.50")
H1 Height	54.0 cm (21.25")
Service clearance	30.5 cm (12.00") top - no front obstructions 15.24 cm (6.00") on exhaust side (left, right and rear)
C1 230 V/50/1 electrical	5.5 amps, 0.8 kW 2.4 m (8') cord only
C2 Water inlet	3/8" FPT installation of an in line water filtration system is recommended
C3 Drain ¹	3/4" MPT
Refrigerant	R290
Air temperature	10 - 38 C (50 - 100 F)
Water temperature	7 - 32 C (45 - 90 F)
Potable water pressure	69 - 483 kPa (10 - 70 psi)
Chewblet ice production at 21 C (70 F) air, 10 C (50 F) water	193 kg (425 lb)
Chewblet ice production at 32 C (90 F) air, 21 C (70 F) water	148 kg (325 lb)
Flake ice production at 32 C (90 F) air, 21 C (70 F) water	193 kg (425 lb)
Energy consumption 32 C (90 F) air, 21 C (70 F) water	5.4 kWh per 45.4 kg (100 lb) ice
Heat rejection	5,000 BTU/hr
Water consumption	45.4 L (12.0 gal) of potable water per 45.4 kg (100 lb) of ice (per AHRI test standards). 47.3 L (12.5 gal) at standard flush setting.
Approximate ship weight	77 kg (170 lb)

NOTES:

For indoor use only.

Configure with a Follett bin. Refer to slope front spec sheet, form# 9135.

SHORT FORM SPECIFICATION: Ice machine to be Follett model number _____.

Ice machine to produce _____ Chewblet,

_____ Micro Chewblet or _____ flake ice. Ice machine to have stainless steel evaporator, auger and top bearings, heavy-duty tapered roller bearings, and low water safety circuit. NSF and CE listed. EU food contact compliant.

Dimensional drawing

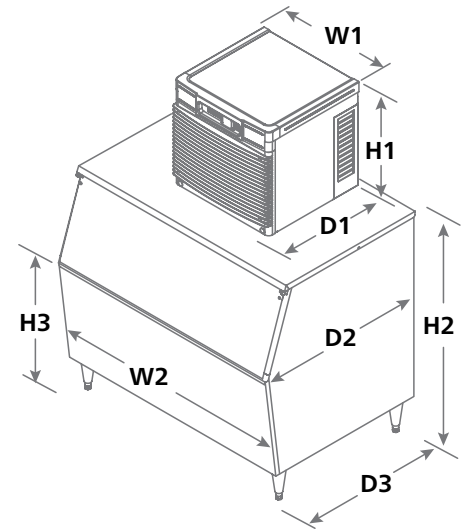

Back view

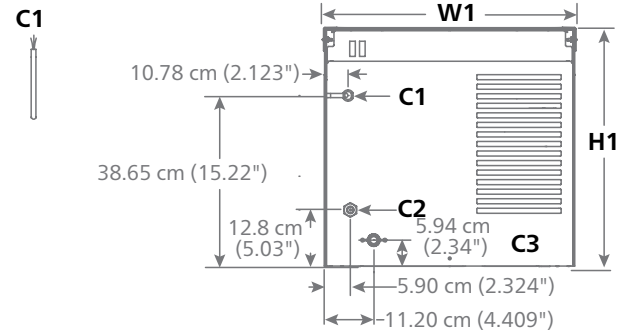

Specification for ice and beverage dispenser top mount ice machines

W1 Width	57.6 cm (22.70") fits on 22.00" wide dispensers
D1 Depth	61.6 cm (24.25")
H1 Height	54.0 cm (21.25")
Service clearance	30.5 cm (12.00") top - no front obstructions 15.24 cm (6.00") on exhaust side (left, right and rear)
C1 230 V/50/1 electrical	5.5 amps, 0.8 kW 2.4 m (8') cord only
C2 Water inlet	3/8" FPT, installation of an in line water filtration system is recommended
C3 Drain	3/4" MPT
Refrigerant	R290
Air temperature	10 - 38 C (50 - 100 F)
Water temperature	7 - 32 C (45 - 90 F)
Potable water pressure	69 - 483 kPa (10 - 70 psi)
Ice production at 21 C (70 F) air, 10 C (50 F) water	193 kg (425 lb)
Ice production at 32 C (90 F) air, 21 C (70 F) water	148 kg (325 lb)
Energy consumption 32 C (90 F) air, 21 C (70 F) water	5.4 kWh per 45.4 kg (100 lb) ice
Heat rejection	5,000 BTU/hr
Water consumption	45.4 L (12.0 gal) of potable water per 45.4 kg (100 lb) of ice (per AHRI test standards). 47.3 L (12.5 gal) at standard flush setting.
Approximate ship weight	77 kg (170 lb)

NOTE: For indoor use only

SHORT FORM SPECIFICATION: Ice machine to be Follett model number _____. Ice machine to produce Chewblet ice. Ice machine to have stainless steel evaporator, auger and top bearings, heavy-duty tapered roller bearing, and low-water safety circuit. NSF and CE listed. EU food contact compliant.

Dimensional drawing

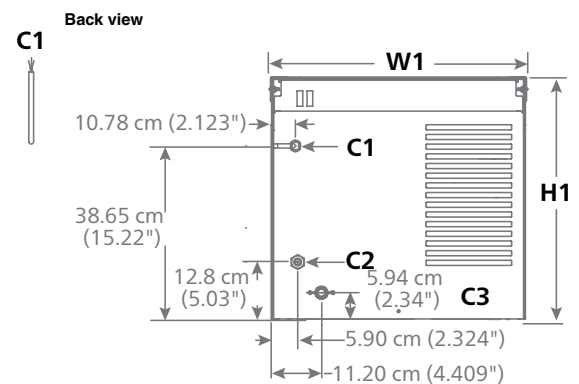
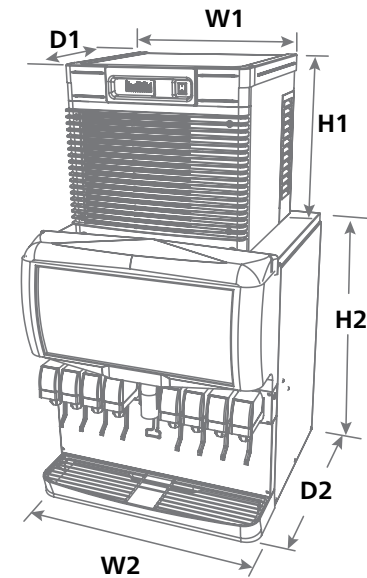

Manufacturer/ Model number	W2 = Width cm (in)	D2 = Depth cm (in)	H2 ¹ = Height cm (in)	Top kit
Coca-Cola dispensers				
Freestyle 7000 ^{2,3}	76.5 (30.10)	84.1 (33.11)	119.4 (47.00)	MTF30SCP
Freestyle 7100 ^{2,4}	76.2 (30.00)	88.8 (33.80)	119.4 (47.00)	MTF30SCP
Freestyle 9000 ²	64.8 (25.50)	90.2 (35.50)	187.3 (73.75)	MTF24SCP
Freestyle 9100 ²	64.8 (25.50)	99.7 (39.25)	196.2 (77.25)	MTF26SCP
Cornelius dispensers				
DB/DF/ED150 series	55.9 (22.00)	76.2 (30.0)	87.3 (34.38)	MTC22SCP
DB/DF/ED175 series	62.2 (24.50)	76.2 (30.0)	87.3 (34.38)	MTC24SCP
DB/DF/ED200 series	76.2 (30.00)	76.2 (30.0)	87.3 (34.38)	MTC30SCP
DB/DF/ED250 series	76.2 (30.00)	76.2 (30.0)	97.5 (38.38)	MTC30SCP
Lancer dispensers				
4500-22N, FS-22N	55.9 (22.00)	77.5 (30.50)	92.7 (36.50)	MTL22SCP
4500-30N	76.2 (30.00)	77.5 (30.50)	92.7 (36.50)	MTL30SCP
FS-30N	76.2 (30.00)	77.5 (30.50)	107.0 (42.13)	MTL30SCP
Lancer Sensation	76.2 (30.00)	78.7 (31.00)	97.2 (38.25)	MTL30SCP
Lancer Touchpoint	82.6 (32.50)	85.6 (33.70)	101.6 (40.00)	MTL30SCP
Pepsi dispensers				
Spire 3.0	68.6 (27.00)	88.9 (35.00)	96.8 (38.12)	MTP24SCP
Spire 5.0 / 4.1	77.5 (30.50)	91.4 (36.00)	108.6 (42.75)	MTP30SCP

¹ Net height after installation of top kit.

² Consult with Coca-Cola and Follett to qualify application prior to ordering.

³ Top adapter IC Code 46412 and ice kit IC Code 46430 must also be ordered from Coca-Cola.

⁴ Top adapter IC Code 46753 and ice kit IC Code 46430 must also be ordered from Coca-Cola.

Chewblet ice production – air-cooled models

Inlet water temperature C (F)	Ambient air temperature C (F)					kg (lb) production in 24 hr
	16 (60)	21 (70)	27 (80)	32 (90)	38 (100)	
10 (50)	208 (460)	193 (425)	177 (390)	161 (355)	145 (320)	
16 (60)	198 (437.5)	184 (405)	169 (372.5)	154 (340)	139 (307.5)	
21 (70)	188 (415)	175 (385)	161 (355)	147 (325)	134 (295)	
27 (80)	184 (405)	170 (375)	156 (345)	142 (315)	129 (285)	
32 (90)	179 (395)	166 (365)	152 (335)	138 (305)	125 (275)	

MAESTRO PLUS and MICRO CHEWBLET are trademarks of Follett Products, LLC.
 CHEWBLET and FOLLETT are registered trademarks of Follett Products, LLC, registered in the US.
 Follett reserves the right to change specifications at any time without obligation. Certifications may vary depending on country of origin.

Maestro Plus E 414 top mount healthcare

