

Symphony Plus™ ice and water dispenser

25 and 50 HI series wall mount with Chewblet® ice machine



SensorSAFE not recommended for use with clear containers or for applications in direct sunlight

Model configurations			
Ice storage capacity	Dispense	Ice machine cooling	Item number
25 lb (11.4 kg)	SensorSAFE	air	25HI425A-S0-00
			25HI425A-S0-DP¹
50 lb (22.7 kg)	SensorSAFE	air	50HI425A-S0-00
			50HI425A-S0-DP¹

¹ Units configured with drain pan.

Ice-only available, replace -S0 with -SI
Example: 25HI425A-SI-00

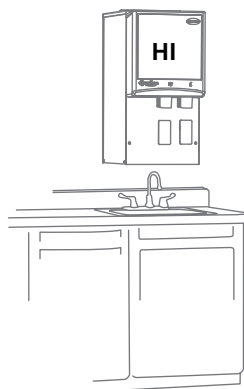

Shown without drain pan

Ice production		
Temperatures air/water	70/50 F (21/10 C)	90/70 F (32/21 C)
Air-cooled	425 lb (193.0 kg)	325 lb (147.6 kg)
Energy consumption per 100 lb (45.4 kg) ice	N/A	6.0 kWh air-cooled
Water consumption	12.0 gal (45.4 L) of potable water per 100 lb (45.4 kg) of ice	

Features

25 or 50 lb (11.4 or 22.7 kg) ice storage capacity

Removable air-cooled ice machine with up to 425 lb (193.0 kg) daily production of Chewblet ice

- soft, chewable, compressed nugget ice is preferred over cubes¹
- Quiet Night™ sleep mode turns off ice machine when idle

Designed with sanitation in mind

- automatic self-flushing of ice machine removes impurities
- drain cup provides internal air gap for added protection of food zone components from drain line contaminants
- Agion® silver-based antimicrobial provides protection of key ice and water contact components²
- SensorSAFE™ infrared ice dispense

Dependable design, easy to service and clean

- cleaning and sanitizing of entire machine takes only 1 hour
- LED control board provides at-a-glance machine status
- panels are easily removed for accessibility to all components
- ice machine parts are common across all Symphony Plus dispensers
- stainless steel evaporator and auger deliver long life

Environmentally responsible

- meets Consortium for Energy Efficiency Tier 2 specifications
- R404a refrigerant has zero ozone depletion potential
- continuous ice making process uses less electricity and water

Durable, attractive dispenser

- stainless steel cabinet with accent trim
- poly drain pan, grille and dispenser lid are corrosion-resistant
- secured top lid

Easy installation

- comes fully assembled and installs with three easy connections – electric, water and drain

Warranty

- 3 years parts and labor, 5 years compressor parts

Accessories

Pressurized water sanitizing kits (refer to form# 1068)

SafeCLEAN Plus™ ice machine cleaner

1 x 8 oz (237 ml) bottle (item# 01147826)

6 x 8 oz (237 ml) bottles (item# 01149954)

Carton of 24 x 8 oz (237 ml) bottles (item# 01149962)

Nu-Calgon® IMS-III sanitizer, 16 oz (0.5 L) bottle (item# 00979674)

Water filters (refer to form# 1058 and 8320)

Additional Symphony Plus accessories (refer to price list)

Specification

Ice storage capacity	25 Series – 25 lb (11.4 kg) 50 Series – 50 lb (22.7 kg)
W1 Width	21.50" (54.6 cm)
D1 Depth, upper cover	24.50" (62.2 cm)
D2 Depth, bottom	17.00" (43.2 cm)
H1 Height	25 Series – 36.50" (92.7 cm) 50 Series – 40.50" (102.9 cm)
Ventilation clearance	3.00" (7.62 cm) all sides
Service clearance	12.00" (30.5 cm) top, 6.00" (15.24 cm) left side
C1 115 V/60/1 electrical	11 amps, 0.8 kW 7' (2.1 m) cord, NEMA 5-15 90° hospital-grade plug
C2 Potable water inlet	3/8" FPT
C3 Drain	3/4" MPT
Utility connection location	through back
K1 Minimum span – wall bracing required in most applications	16.00" (40.6 cm) on center NOTE: Wall mount bracket standard
K2 Maximum height from sink	18.00" (45.7 cm)
K3 Minimum distance from wall to front of sink	30.00" (76.2 cm)
K4 Minimum sink width	21.00" (53.3 cm) centered on dispenser, 14.50" (36.8 cm) centered on chutes
K5 Minimum sink depth	16.00" (40.6 cm)
Air temperature	50 -100 F (10 - 38 C) indoor use only
Water temperature	45 - 90 F (7 - 32 C)
Water pressure	10 - 70 psi (69 - 483 kpa)
Heat rejection	5000 BTU/hr
Water consumption	12.0 gal (45.4 L) of potable water per 100 lb (45.4 kg) of ice
Approximate net weight	199 lb (90 kg)
Approximate ship weight	239 lb (108 kg)

NOTE: For indoor use only

SHORT FORM SPECIFICATION: (Choose one) ___ Ice and water or ___ ice-only dispenser to be Follett® automatic load in wall mount configuration, with ___ 25 lb (11.4 kg) or ___ 50 lb (22.7 kg) of storage. Environmentally responsible R404a ice machine to be air-cooled and to be removable for cleaning and maintenance. Ice machine to produce approximately 425 lb (193.0 kg) of Chewblet compressed nugget ice at air temp. of 70 F (21 C), water temp. of 50 F (10 C). Ice machine equipped with automatic self-flushing and Quiet Night sleep mode. Dispenser to have automatic bin level control to start and stop ice machine and lightweight plastic top that allows full access to the ice storage area for easy cleaning and manual loading of back-up ice. Storage area to be insulated with CARB compliant non-HFC foam. 7' (2.1 m) cord and NEMA 5-15 90° hospital-grade plug provided. NSF and ETL listed.

Dimensional drawing

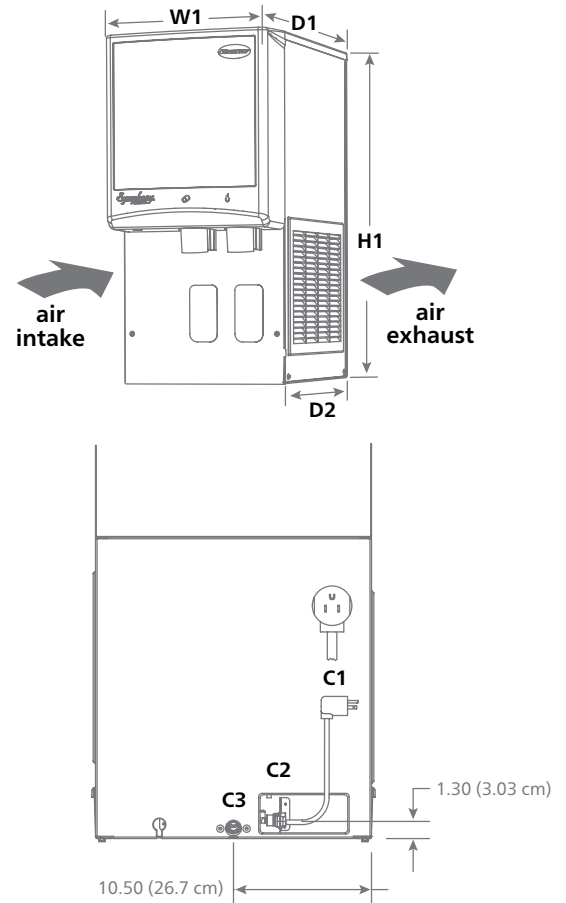

Wall mount detail

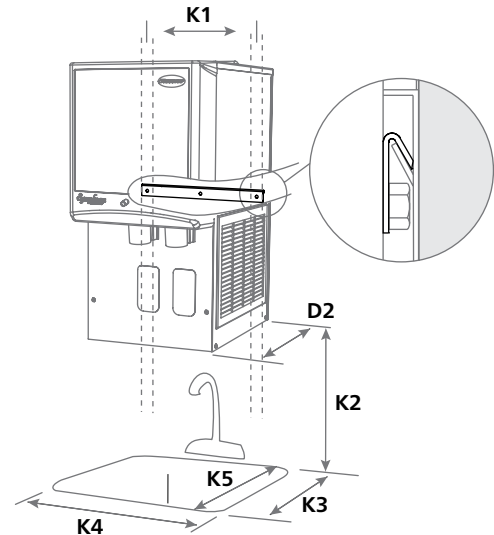

¹ Independent third party studies. Contact Follett for details.

²Disclaimer: Antimicrobial protection is limited to the treated components and does not treat water or ice.

Agion is a registered trademark of Sciesent LLC.

Calgon is a licensed tradename distributed by Nu-Calgon, in the United States.

SYMPHONY PLUS, SENSORSAFE, SAFECLEAN PLUS and QUIET NIGHT are trademarks of Follett Products, LLC.

CHEWBLET and FOLLETT are registered trademarks of Follett Products, LLC, registered in the US.

Follett reserves the right to change specifications at any time without obligation. Certifications may vary depending on country of origin.

25/50 HI series wall mount