

Marine CVU155 and 300 series ice and water dispenser



CVU155N0LP

CVU155N series – 150 lb (68 kg) ice storage		
Ice tower location	Valve type	Item number
left	push-button	CVU155N0LP
right	push-button	CVU155N0RP
CVU300N series – 300 lb (136 kg) ice storage		
Ice tower location	Valve type	Item number
left	push-button	CVU300N0LP
right	push-button	CVU300N0RP

Features

Up to 150 or 300 lb (68 or 136 kg) undercounter ice storage

Upscale drink station

- designed for marine applications to address United States Public Health Service (USPHS) principles
- low profile with ice storage under the counter
- autofill with an ice machine out of view using RIDE® remote ice delivery equipment
- ideal for island configurations
- fits into ADA compliant 34.00" (86.3 cm) counters

Left or right side ice dispense chute

Durable, full stainless exterior

Pre-configured for Follett® RIDE model Chewblet® ice machines

- connect up to two Follett ice machines
- consumer-preferred, chewable compressed nugget ice
- slow melting, maintains drink temperature

Faster, safer manual loading of ice at waist height

- safe, easy waist-height loading front or rear
- eliminates overhead lifting of buckets or loading from ladders
- allows quick reloading during serving period with minimal disruption
- may be manually loaded with cube ice up to 1.00" (2.54 cm) square or Chewblet ice

Certifications (applied to all products unless otherwise noted)



Options and accessories¹

4.00" (10.16 cm) stainless steel leg (individual) adjustable to 6.75" (17.15 cm) for VU300 series only (item# 00137257)

¹ Certifications do not apply to options and accessories.

CVU155N Specification

Ice storage capacity	150 lb (68 kg)
W1 Width	31.25" (79.4 cm)
W2 Width, tower	12.00" (30.5 cm)
D1 Depth	27.38" (69.6 cm)
D2 Depth, tower	12.00" (30.5 cm)
D3 Depth, drain pan interior	7.25" (18.42 cm)
H1 Height, upper section	22.00" (55.9 cm)
H2 Height, lower section	27.88" (70.8 cm)
H3 Height, leg	adjustable 6.00" - 9.00" (15.24 - 22.86 cm)
H4 Ice dispense height clearance	10.00" (25.4 cm)
K1 Ice dispense chute	utility connections are on opposite side of ice dispense chute
Installation clearance	51.00" (129.5 cm) above counter for drop-in installation, 1.25" (3.18 cm) maximum counter thickness
Service clearance	12.00" (30.5 cm) minimum on ice transport tube entry side for connections, 36.00" (91.4 cm) minimum above counter for auger removal
C1 Electrical	2.0 amps. Waterproof junction box. Separate circuits and disconnects required for each dispenser.
220 V/60/1	
C2 Drain - ice storage	3/4" PVC slip joint
C3 Water inlet	3/8" ID hose
C4 Drain - drain pan	3/4" PVC hose
C5 Bin signal switch	Pre-wired bin signal junction box with twist lock connector(s). Standard length is 20' (6.1 m).
C6 Ice machine ice transport tube connection (12.00" clearance on side for ice tube entry)	two ice transport tube entry holes on each side
C7 Air break	do not connect to drain system
Approximate net weight	201 lb (91 kg)
Approximate shipping weight	232 lb (105 kg)
NOTE: For indoor use only	

SHORT FORM SPECIFICATION: Ice and water dispenser to be Follett model _____. Dispenser to store up to 150 lb (68 kg) of ice and allow loading of ice at waist level from front or rear. Ice and water tower and top to be of stainless steel with plastic trim. Full-length drain pan to be one-piece molded polyethylene. To include 6.00" - 9.00" (15.24- 22.86 cm) adjustable legs for dispenser support. Storage area to be insulated with CARB compliant non-HFC foam. Dispenser to be pre-configured to accept up to two _____ RIDE model ice machines, sold separately.

CVU155N Dimensional drawing

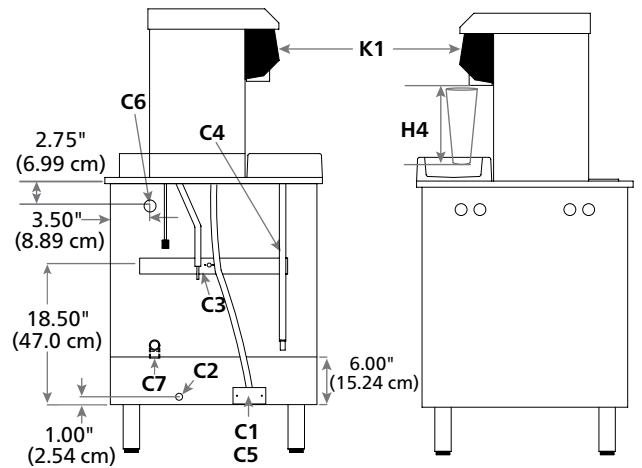
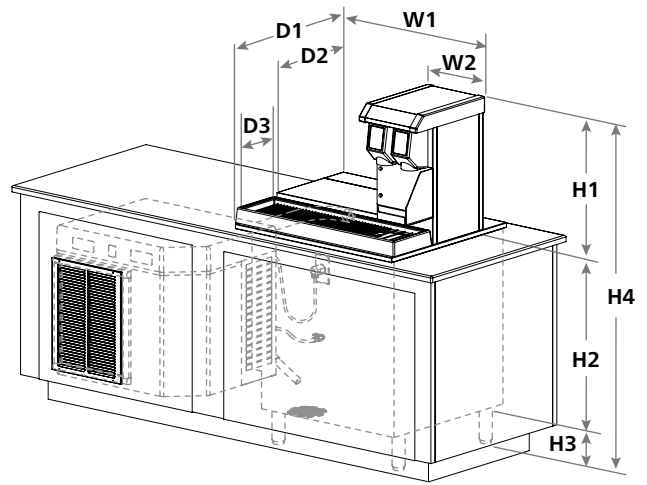

CVU155N Counter cutout detail

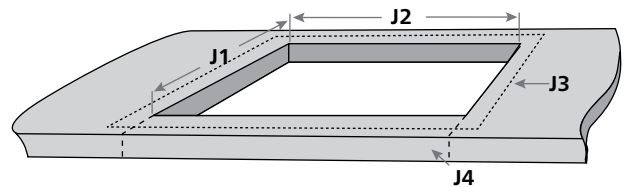

J1 Cutout depth	26.25" (66.67 cm) ± 0.125" (0.32 cm)
J2 Cutout width	30.375" (77.152 cm) ± 0.125" (0.32 cm)
J3 Flat surface required	31.25" W x 28.00" D (79.37 cm x 71.12 cm)
J4 Optional - counter front may be removed for slide-in installation	

CVU155 series

CVU300N Specification

Ice storage capacity	300 lb (136 kg)
W1 Width	40.75" (103.5 cm)
W2 Width, tower	14.38" (36.5 cm)
D1 Depth	32.38" (82.2 cm)
D2 Depth, tower	24.62" (62.5 cm)
D3 Depth, drain pan interior	9.38" (23.8 cm)
H1 Height, upper section	25.25" (64.1 cm)
H2 Height, lower section	29.62" (75.2 cm)
H3 Height, leg	adjustable 4.00" - 6.75" (10.16 - 17.14 cm)
H4 Ice dispense height clearance	10.88" (27.64 cm)
K1 Ice dispense chute	utility connections are on same side as ice dispense chute
Installation clearance	60.00" (152.4 cm) above counter for drop-in installation, 1.25" (3.18 cm) maximum counter thickness
Service clearance	12.00" (30.5 cm) minimum on ice transport tube entry side for connections, 49.00" (124.5 cm) minimum above counter for auger removal
C1 Electrical	1.5 amps. Waterproof junction box. Separate circuits and disconnects required for each dispenser.
C2 Drain - ice storage	3/4" FPT - supplied with air break
C3 Water inlet	3/8" ID hose
C4 Drain - drain pan	3/4" drain nipple
C5 Ice machine electrical connection	Pre-wired bin signal junction box with twist lock connector(s). Standard length is 20' (6.1 m).
C6 Ice machine ice transport tube connection	two ice transport tube entry holes on each side
Approximate net weight	314 lb (143 kg)
Approximate shipping weight	354 lb (161 kg)
NOTE: For indoor use only	

SHORT FORM SPECIFICATION: Ice and water dispenser to be Follett model _____. Dispenser to store up to 300 lb (136 kg) of ice and allow loading of ice at waist level from front. Ice and water tower and top to be of stainless steel with plastic trim. Full-length drain pan to be one-piece molded polyethylene. To include 4.00" - 6.75" (10.16 - 17.15 cm) adjustable legs for dispenser support. Storage area to be insulated with CARB compliant non-HFC foam. Dispenser to be pre-configured to accept up to two _____ RIDE model ice machines, sold separately.

CVU300N Dimensional drawing

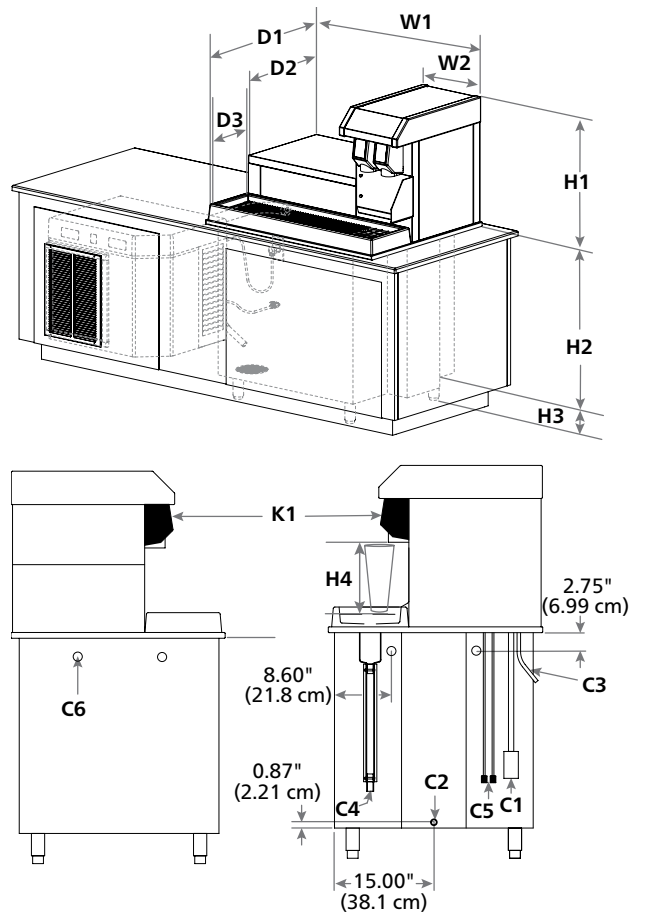

CVU300N Counter cutout detail

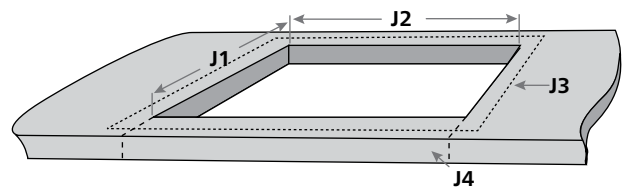

J1 Cutout depth	30.375" (77.152 cm) ± 0.125" (0.32 cm)
J2 Cutout width	38.50" (97.79 cm) ± 0.125" (0.32 cm)
J3 Flat surface required	40.875" W x 33.00" D (103.822 cm x 88.82 cm)
J4 Optional - counter front may be removed for slide-in installation	

VISION is a trademark of Follett Products, LLC. CHEWBLET, FOLLETT and RIDE are registered trademarks of Follett Products, LLC, registered in the US. Follett reserves the right to change specifications at any time without obligation. Certifications may vary depending on country of origin.

CVU300 series

